

NOTES:

- MATERIALS:
 - HOUSING: 30% GLASS FILLED, LCP 94V-0, COLOR BLACK
 - TERMINALS: COPPER ALLOY
- PLATING:
 - 0.76 MICROMETER (30 MICROINCH) MINIMUM GOLD IN CONTACT AREA
 - SELECTIVE MATTE TIN ON PCB TAILS
 - NICKEL UNDERPLATE OVERALL
- PLUG MATES WITH RECEPTACLE ASSEMBLY 46079-10**
- MODULE IS DESIGNED FOR PRESS FIT TO THE PCB
- MODULE ASSEMBLY IS RoHS COMPLIANT
- MODULES TO BE UL & CSA LISTED PER UL-1977
- AVERAGE INSERTION FORCE INTO PCB IS 8.2 kg/18 lbs PER TAIL
- PRODUCT PERFORMANCE AND RATING PER PS-75431-****
- APPLICATION SPEC PER AS-75541-****
- RECOMMENDED PCB DRILL HOLE DIA 1.180/0465 (#56 DRILL)
- FOR MODULE CONFIGURATION SEE DRAWING SD-75541-001

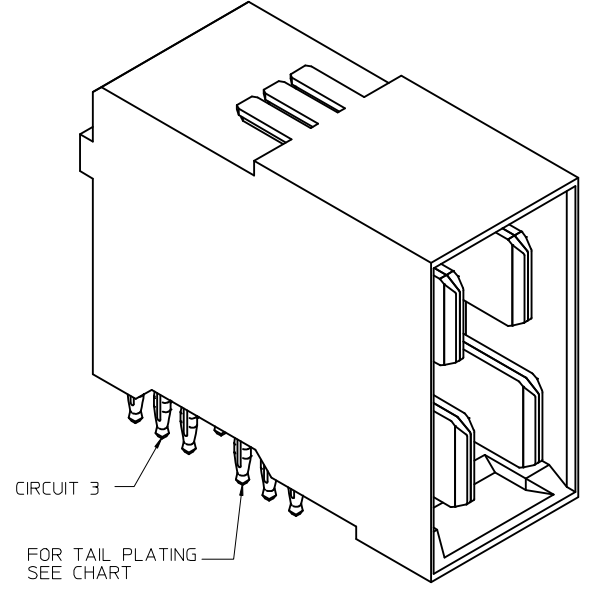

UPDATE PER ISIR EC NO: 2015/02/17 DRWN: JQUILES CHKD: MBANDURA APPR: APATEL 2015/02/17 2015/02/17 2015/02/17	QUALITY SYMBOLS ∇=0 ∇=0 ∇=0	GENERAL TOLERANCES (UNLESS SPECIFIED)		DIMENSION STYLE MM/IN		SCALE 2:1	DESIGN UNITS METRIC	THIRD ANGLE PROJECTION		
		4 PLACES ± --- ± ---	mm	INCH	DRAWN BY JQUILES	DATE 2005/08/01	ASSEMBLY - PLUG 4 CIRCUIT - PRESS FIT MULTI PATH molex			
		3 PLACES ± --- ± .008			CHECKED BY MDATA	DATE 2005/08/04				
		2 PLACES ± 0.20 ± .013			APPROVED BY APATEL	DATE 2005/08/05	MATERIAL NO. 46081-1000		DOCUMENT NO. SD-46081-100	
1 PLACE ± 0.33 ± ---			ANGULAR ±1/2°		DRAFT WHERE APPLICABLE MUST REMAIN WITHIN DIMENSIONS		SHEET NO. 1 OF 1			
0 PLACE ± ±			SIZE C		THIS DRAWING CONTAINS INFORMATION THAT IS PROPRIETARY TO MOLEX INCORPORATED AND SHOULD NOT BE USED WITHOUT WRITTEN PERMISSION					

PART NUMBER	DIM "A"
46081-2000	3.07/.121
46081-2010	3.81/.150

NOTES:

- MATERIALS:
 - HOUSING: 30% GLASS FILLED, LCP 94V-0, COLOR BLACK
 - TERMINALS: COPPER ALLOY
- PLATING:
 - 0.76 MICROMETER (30 MICROINCH) MINIMUM GOLD IN CONTACT AREA
 - SELECTIVE MATTE TIN ON PCB TAILS
 - NICKEL UNDERPLATE OVERALL
- PLUG MATES WITH RECEPTACLE ASSEMBLY 46079-10**
- MODULE IS DESIGNED FOR PC TAILS TO THE PCB
- MODULE ASSEMBLY IS RoHS COMPLIANT
- MODULES TO BE UL & CSA LISTED PER UL-1977
- PRODUCT PERFORMANCE AND RATING PER PS-75431-****
- APPLICATION SPEC PER AS-75541-****
- RECOMMENDED PCB DRILL HOLE DIA 1.180/0465 (#56 DRILL)
- FOR MODULE CONFIGURATION SEE DRAWING SD-75541-001

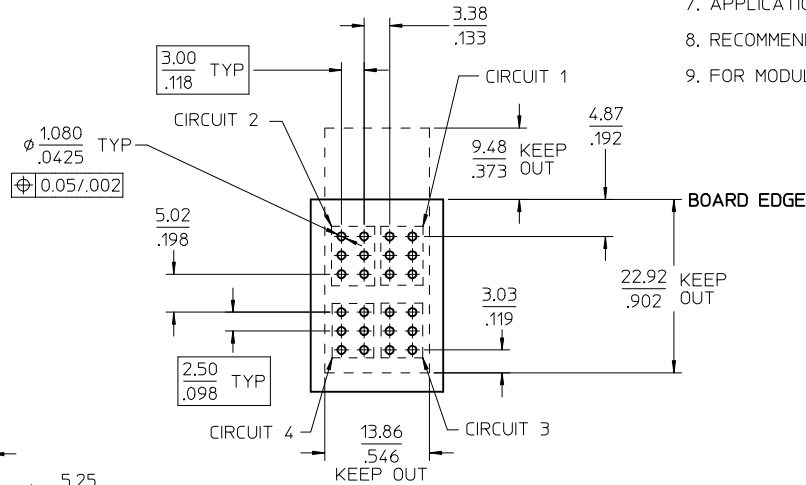
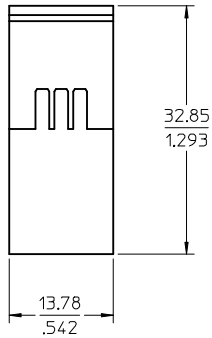

**PCB LAYOUT
2.40/.094 MAX THICK**

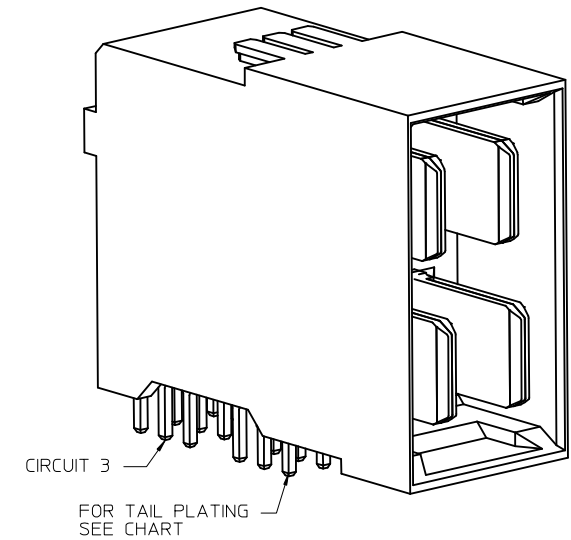
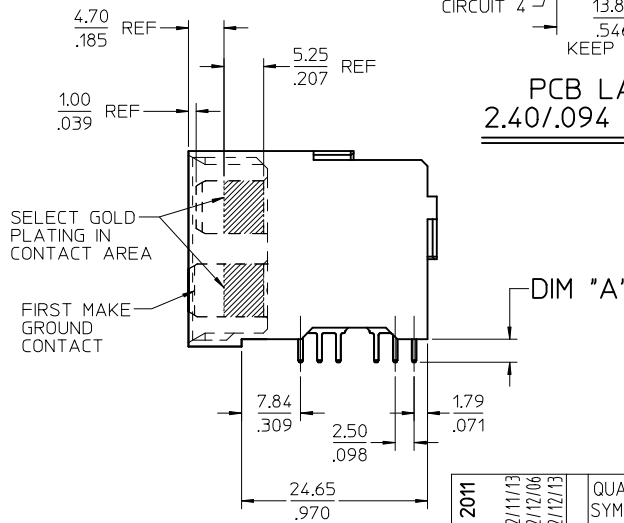
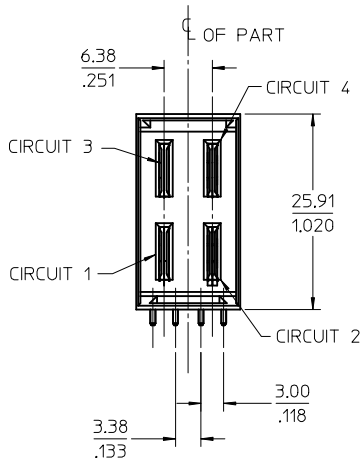

REM 46081-2001 & 2011 IEC NO: 2012/11/13 DRWN:BBARKER CHKD:MBANDURA APPR:APATEL 2012/12/06 2012/12/13 2012/12/13	QUALITY SYMBOLS ▽=0 ▽=0 ▽=0	GENERAL TOLERANCES (UNLESS SPECIFIED)		DIMENSION STYLE MM/IN	SCALE 2:1	DESIGN UNITS METRIC	THIRD ANGLE PROJECTION		
		4 PLACES ± --- ± --- 3 PLACES ± --- ± .005 2 PLACES ± 0.13 ± .010 1 PLACE ± 0.25 ± --- 0 PLACE ± ±	mm INCH ± --- ± --- ± 0.13 ± .010 ± 0.25 ± --- ± ±	DRAWN BY MDATA	DATE 2005/12/14	CHECKED BY APATEL	DATE 2005/12/15	ASSEMBLY - PLUG 4 CIRCUIT - PC TAILS MULTI PATH molex	
		ANGULAR ±1/2°		MATERIAL NO. SEE CHART	DATE 2005/12/20	APPROVED BY APATEL	DATE 2005/12/20		
		DRAFT WHERE APPLICABLE MUST REMAIN WITHIN DIMENSIONS	SIZE C	THIS DRAWING CONTAINS INFORMATION THAT IS PROPRIETARY TO MOLEX INCORPORATED AND SHOULD NOT BE USED WITHOUT WRITTEN PERMISSION				SHEET NO. 1 OF 1	