



AP1021AEN

32V Dual Microstepping Motor Driver IC with SPI

1. General Description

The AP1021 is a complete microstepping motor driver that can drive two stepper motors, to operate up to 28V motor supply voltage. N-channel LDMOS FETs are built in both high and low side for output driver to achieve small package. It also includes under voltage detection and thermal shut down circuits. It is suitable for driving various types of stepper motors.

2. Features

- Built-in PWM Current Control Stepper Motor Driver
- SPI Interface
- Full Programmable Excitation Mode up to 1/64 step
- Control Supply Voltage (VC) 3.0V to 5.5V
- Motor Drive Operating Voltage (VM) 2.0V to 28V
- H-Bridge On Resistance 1.0Ω
- Adjustable PWM Motor Current by VIS pins.
- Built-in UVLO(Under Voltage Lock Out circuit)
- Built-in TSD(Thermal Shut Down circuit)
- Built-in Charge Pump Circuit
- Operating Temperature Range -40°C to +85°C
- Small 32-pin QFN (5mm×5mm) Package

3. Table of Contents

1. General Description	1
2. Features	1
3. Table of Contents	2
4. Block Diagram	3
5. Ordering Guide	4
6. Pin Configurations and Functions	4
■ Pin Configurations	4
■ Pin Functions	5
7. Absolute Maximum Ratings	6
8. Recommended Operation Condition	6
9. Electrical Characteristics	7
10. Functional Descriptions	8
■ Enable mode	8
■ ISn terminal current	9
■ SPI Interface	14
■ Register map	17
■ Register Description	17
11. Recommended External Circuits	20
12. Package	22
■ Outline Dimensions	22
■ Marking	22
13. Revise History	23
IMPORTANT NOTICE	24

4. Block Diagram

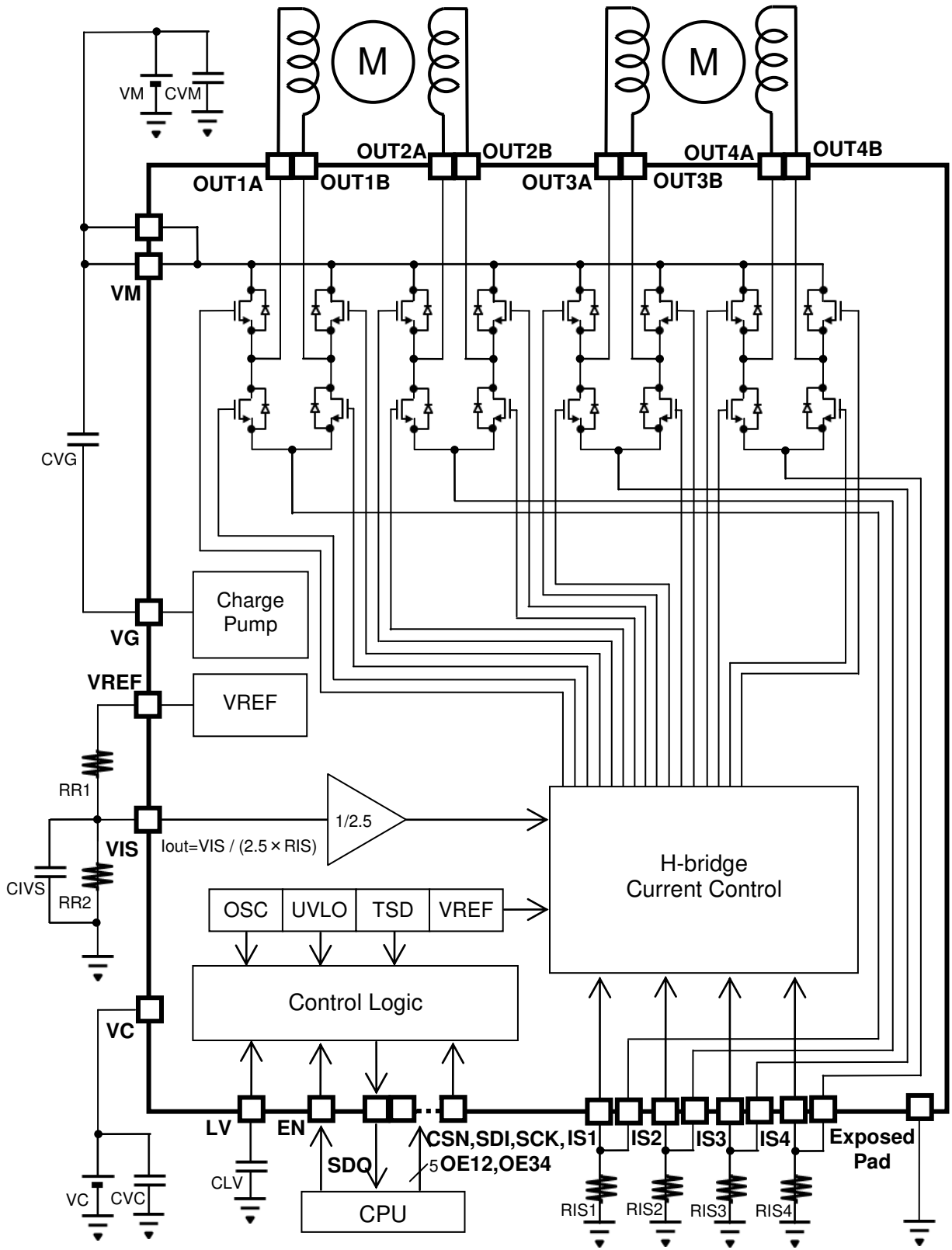

Figure 1. Block Diagram

5. Ordering Guide

AP1021AEN

-40~85°C

32-pin QFN

6. Pin Configurations and Functions

■ Pin Configurations

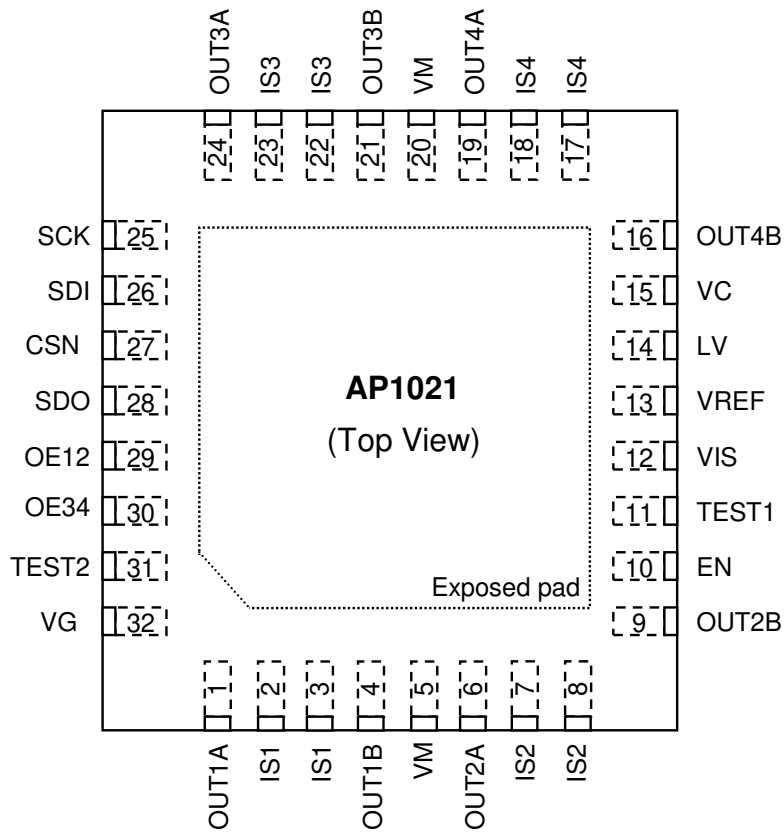

Exposed Pad must be connected to GND.

■ Pin Functions

No.	Pin Name	Type (Note 1)	I/O (Note 2)	Function	Remark
1	OUT1A	A	O	Motor driver output	
2, 3	IS1	A	IO	Current sense terminal	
4	OUT1B	A	O	Motor driver output	
5, 20	VM	P	-	Motor driver power supply	
6	OUT2A	A	O	Motor driver output	
7, 8	IS2	A	IO	Current sense terminal	
9	OUT2B	A	O	Motor driver output	
10	EN	D	I	Chip Enable (Power save)	200kΩ Pull-down
11	TEST1	A	I	TEST pin. This pin must be connected to the ground.	
12	VIS	A	I	Motor current set voltage input	
13	VREF	A	O	Voltage reference	
14	LV	A	O	Logic voltage output capacitor connection	
15	VC	P	-	Control power supply	
16	OUT4B	A	O	Motor driver output	
17, 18	IS4	A	I	Current sense terminal	
19	OUT4A	A	O	Motor driver output	
21	OUT3B	A	O	Motor driver output	
22, 23	IS3	A	IO	Current sense terminal	
24	OUT3A	A	O	Motor driver output	
25	SCK	D	I	Control data clock	
26	SDI	D	I	Control data input	
27	CSN	D	I	Chip select	
28	SDO	D	I	Control data output	
29	OE12	D	I	OUT1/2 Output Enable when SELOE register bit=H	
30	OE34	D	I	OUT3/4 Output Enable when SELOE register bit=H	
31	TEST2	D	I	TEST pin. This pin must be connected to the ground.	
32	VG	A	IO	Charge-pump output voltage	
Exposed Pad	EP	GND	-	Ground	(Note 3)

Note 1. A(analog pin), D(digital pin), GND(ground pin), P(power pin)

Note 2. I(input pin), O(output pin), IO(input/output pin)

Note 3. Exposed Pad must be connected to GND.

7. Absolute Maximum Ratings

Parameter	Symbol	min	max	Unit	Remark
Control supply voltage	VC	-0.5	5.5	V	
Motor driver supply voltage	VM	-0.5	32	V	
VC level terminal (EN, CSN, SCK, SDI, SDO, OE12, OE34)	Vterm1	-0.5	VC	V	
VM level terminal (OUTnA, OUTnB)	Vterm2	-0.5	VM	V	
1.8V level terminal (LV, VREF, VIS)	Vterm3	-0.5	1.9	V	
1.2V level terminal (ISn)	Vterm4	-0.5	1.3	V	
Maximum output current	IloadDC	-	1.2	A	Dual use (Note 8)
	IloadPeak	-	1.7	A	Single use (Note 9)
	Ipulse	-	2.8	A	Pulsed $t_w < 1\mu s$
Power dissipation	PD	-	3.9	W	$T_a = 25^\circ C$
Junction temperature	Tj	-	150	$^\circ C$	
Storage temperature	Tstg	-40	150	$^\circ C$	

Note 4. All above voltage are defined to GND.

Note 5. Product quality may suffer if the absolute maximum rating is exceeded even momentarily for any parameter. That is, the absolute maximum ratings are rated values at which the products on the verge of suffering physical damages, and therefore products must be used under conditions that ensure that the absolute maximum ratings are not exceeded.

Note 6. When 4 layer board is used, this is calculated $\theta_{JA} = 32^\circ C/W$. EP terminal is connected ground.

Note 7. The each power supply of VM and VC is sequence-free.

Note 8. The AP1021 drives two stepper motors at the same time.

Note 9. For Power Dissipation, the output current rating may be limited by duty cycle, T_a , and PCB board heat sinking design.

8. Recommended Operation Condition

Parameter	Symbol	min	typ	max	Unit	Remark
Motor driver supply voltage	VM	2.0	24.0	28.0	V	
Control supply voltage	VC	3.0	5.0	5.5	V	
VIS input voltage range	VIS	0.2	-	VREF	V	$I_o = (VIS/2.5)/RISn$
Operating Temperature range	Ta	-40	-	85	$^\circ C$	

Note 10. All above voltage are defined to GND.

9. Electrical Characteristics

(Ta = 25°C, VM=24V, VC = 5.0V, unless otherwise specified.)

Parameter	Symbol	Conditions	min	typ	max	Unit
Quiescent current						
VC Quiescent current at OFF	I _{VCOFF}	EN="L"	-	-	10	μA
VM Quiescent current at OFF	I _{VMOFF}	EN="L"	-	-	20	μA
VC Quiescent current at operate	I _{VC}	EN="H" SCK = 2MHz Current data increment speed = 1kHz	-	1.6	3.0	mA
H-bridge circuit						
Driver on resistance (High side + Low side)	R _{ONI}	I _{load} 1ch/2ch = 100mA/100mA Ta = 25°C	-	1.0	1.3	Ω
Body diode forward voltage	V _F	I _F = 100mA	-	0.8	1.2	V
Control logic						
Input High level voltage	V _{IH}	VC = 3.0V-5.5V	0.7xVC	-	-	V
Input Low level voltage	V _{IL}		-	-	0.3xVC	V
Input pulse rise time (OE12, OE34 pin)	t _R		-	-	1.0	μs
Input pulse fall time (OE12, OE34 pin)	t _F		-	-	1.0	μs
Input High level current	I _{IH}		-1.0	-	1.0	μA
Input High level current (EN pin)	I _{IHEN}		15	25	40	μA
Input Low level current	I _{IL}		-1.0	-	1.0	μA
Reference voltage						
VREF terminal voltage	V _{REF}	I _{load} = -100μA	1.22	1.25	1.28	V
Current operation						
Blanking time	t _B		2.4	3.0	3.6	μs
VIS offset voltage	V _{OSIS}		-50	0	50	mV
Protection circuit						
VC under voltage detect voltage	V _{CUV}		1.9	2.2	2.5	V
Thermal shut down temperature	T _{TSD}	Design certification (Note 12)	150	175	200	°C
Temperature hysteresis	T _{TSDHYS}	Design certification (Note 12)	-	30	-	°C

Note 11. All above voltage are defined to GND.

Note 12. Not tested under mass-production.

10. Functional Descriptions

■ Enable mode

AP1021 can set outputs as Enable mode (Hi-Z) by registers or pins. When OE12 bit or OE34 bit is set to “0” → “1” during SELOE bit = “0”, the outputs of OUT1/2 or OUT3/4 pin is set to Hi-Z. When OE12 pin or OE34 pin is set to “L” → “H” during SELOE bit = “1”, the outputs of OUT1/2 or OUT3/4 pin is set to Hi-Z.

Table 1. Enable mode setting (x: Don't care)

SELOE bit	OE12 bit	OE34 bit	OE12 pin	OE34 pin	OUT1/2 pin	OUT3/4 pin	
“0”	“0”	“0”	x	x	Hi-Z	Hi-Z	(default)
“0”	“0”	“1”	x	x	Hi-Z	Normal operate	
“0”	“1”	“0”	x	x	Normal operate	Hi-Z	
“0”	“1”	“1”	x	x	Normal operate	Normal operate	
“1”	x	x	“L”	“L”	Hi-Z	Hi-Z	
“1”	x	x	“L”	“H”	Hi-Z	Normal operate	
“1”	x	x	“H”	“L”	Normal operate	Hi-Z	
“1”	x	x	“H”	“H”	Normal operate	Normal operate	

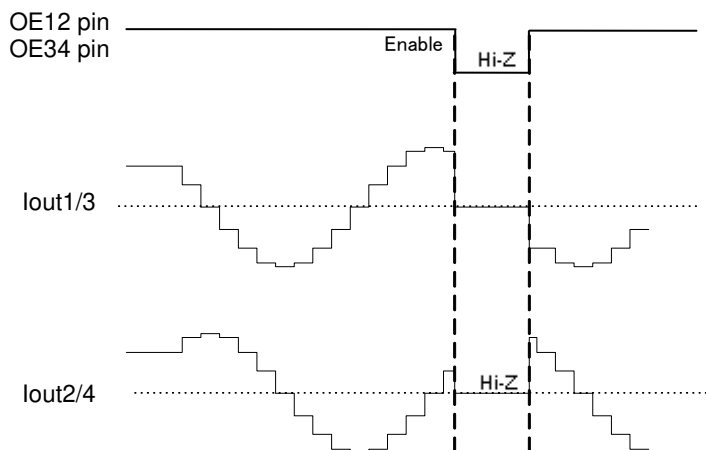

Figure 2. The example of an Enable mode setup by OE12 & OE34 pin
The figure is an image figure of 1/4step.

■ **ISn terminal current**

AP1021 sets up the excitation mode of 1/64 step and the output current for every step by the register control of 4-wire serial interface.

- Direction of Current

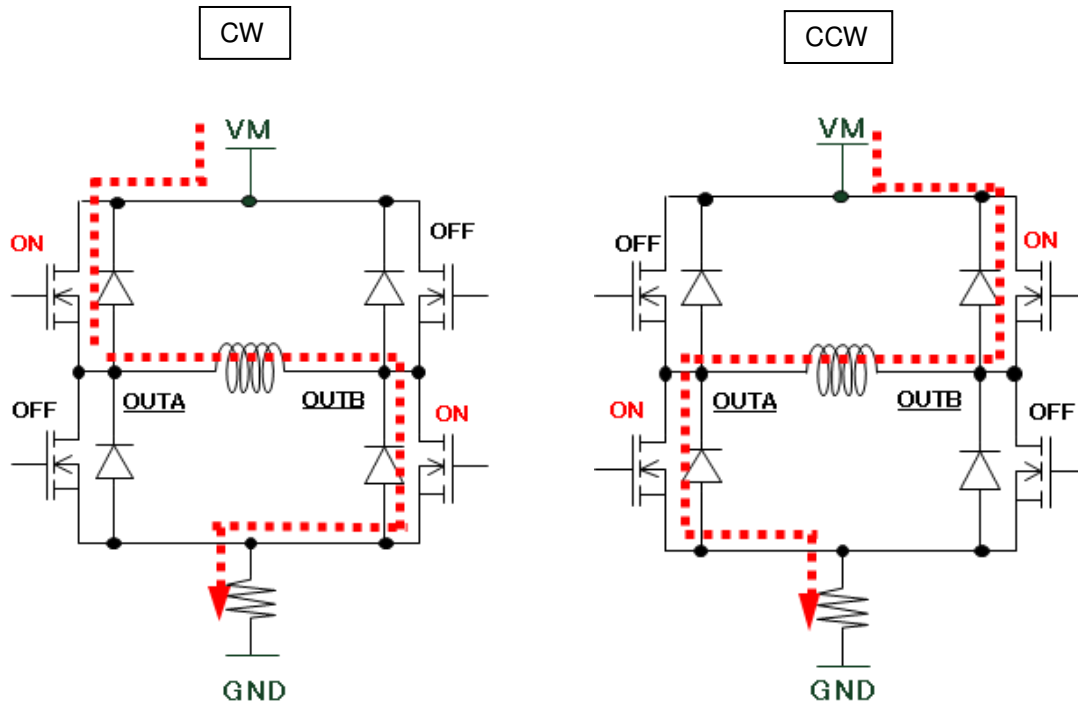

Figure 3. Dimming Characteristics with the DIM pin

•ISn terminal current in case of 1/64 step

Step#	Output Current	Direction of Current	Output Current	Direction of Current	STEP12 STEP34	
	IS1/3[%]	OUT1/3	IS2/4[%]	OUT2/ 4	(bin)	(hex)
0	100	CW	0	X	10010000	90
1	100		2	CW	10010001	91
2	100		5		10010011	93
3	100		7		10010010	92
4	100		10		10010110	96
5	99		12		10010111	97
6	99		15		10010101	95
7	98		17		10010100	94
8	98		20		10011100	9C
9	98		22		10011101	9D
10	97		24		10011111	9F
11	96		27		10011110	9E
12	96		29		10011010	9A
13	95		31		10011011	9B
14	94		34		10011001	99
15	93		36		10011000	98
16	93		38		10001000	88
17	91		40		10001001	89
18	91		43		10001011	8B
19	89		45		10001010	8A
20	88		47		10001110	8E
21	87		49		10001111	8F
22	86		51		10001101	8D
23	84		53		10001100	8C
24	83		56		10000100	84
25	82		58		10000101	85
26	80		60		10000111	87
27	79		62		10000110	86
28	77		64		10000010	82
29	76		65		10000011	83
30	74		67		10000001	81
31	73		69		10000000	80
32	71		71		00000000	00
33	69		73		00000001	01
34	67		74		00000011	03
35	65		76		00000010	02
36	64		77		00000110	06
37	62		79		00000111	07
38	60		80		00000101	05
39	58		82		00000100	04
40	56		83		00001100	0C
41	53		84		00001101	0D
42	51		86		00001111	0F
43	49		87		00001110	0E
44	47		88		00001010	0A
45	45		89		00001011	0B
46	43		91		00001001	09
47	40		91		00001000	08
48	38		93		00011000	18
49	36		93		00011001	19
50	34		94		00011011	1B
51	31		95		00011010	1A
52	29		96		00011110	1E
53	27		96		00011111	1F
54	24		97		00011101	1D
55	22		98		00011100	1C
56	20		98		00010100	14
57	17		98		00010101	15
58	15		99		00010111	17
59	12		99		00010110	16
60	10		100		00010010	12
61	7		100		00010011	13
62	5		100		00010001	11
63	2		100		00010000	10

Step#	Output Current	Direction of Current	Output Current	Direction of Current	STEP12 STEP34	
	IS1/3[%]	OUT1/3	IS2/4[%]	OUT2/ 4	(bin)	(hex)
64	0	X	100	CW	00110000	30
65	2	CCW	100		00110001	31
66	5		100		00110011	33
67	7		100		00110010	32
68	10		100		00110110	36
69	12		99		00110111	37
70	15		99		00110101	35
71	17		98		00110100	34
72	20		98		00111100	3C
73	22		98		00111101	3D
74	24		97		00111111	3F
75	27		96		00111110	3E
76	29		96		00111010	3A
77	31		95		00111011	3B
78	34		94		00111001	39
79	36		93		00111000	38
80	38		93		00101000	28
81	40		91		00101001	29
82	43		91		00101011	2B
83	45		89		00101010	2A
84	47		88		00101110	2E
85	49		87		00101111	2F
86	51		86		00101101	2D
87	53		84		00101100	2C
88	56		83		00100100	24
89	58		82		00100101	25
90	60		80		00100111	27
91	62		79		00100110	26
92	64		77		00100010	22
93	65		76		00100011	23
94	67		74		00100001	21
95	69		73		00100000	20
96	71		71		01100000	60
97	73		69		01100001	61
98	74		67		01100011	63
99	76		65		01100010	62
100	77		64		01100110	66
101	79		62		01100111	67
102	80		60		01100101	65
103	82		58		01100100	64
104	83		56		01101100	6C
105	84		53		01101101	6D
106	86		51		01101111	6F
107	87		49		01101110	6E
108	88		47		01101010	6A
109	89		45		01101011	6B
110	91		43		01101001	69
111	91		40		01101000	68
112	93		38		01111000	78
113	93		36		01111001	79
114	94		34		01111011	7B
115	95		31		01111010	7A
116	96		29		01111110	7E
117	96		27		01111111	7F
118	97		24		01111101	7D
119	98		22		01111100	7C
120	98		20		01110100	74
121	98		17		01110101	75
122	99		15		01110111	77
123	99		12		01110110	76
124	100		10		01110010	72
125	100		7		01110011	73
126	100		5		01110001	71
127	100		2		01110000	70

Step#	Output Current	Direction of Current	Output Current	Direction of Current	STEP12 STEP34	
	IS1/3[%]	OUT1/3	IS2/4[%]	OUT2/ 4	(bin)	(hex)
128	100	CCW	0	X	01010000	50
129	100		2	CCW	01010001	51
130	100		5		01010011	53
131	100		7		01010010	52
132	100		10		01010110	56
133	99		12		01010111	57
134	99		15		01010101	55
135	98		17		01010100	54
136	98		20		01011100	5C
137	98		22		01011101	5D
138	97		24		01011111	5F
139	96		27		01011110	5E
140	96		29		01011010	5A
141	95		31		01011011	5B
142	94		34		01011001	59
143	93		36		01011000	58
144	93		38		01001000	48
145	91		40		01001001	49
146	91		43		01001011	4B
147	89		45		01001010	4A
148	88	47		01001110	4E	
149	87	49		01001111	4F	
150	86	51		01001101	4D	
151	84	53		01001100	4C	
152	83	56		01000100	44	
153	82	58		01000101	45	
154	80	60		01000111	47	
155	79	62		01000110	46	
156	77	64		01000010	42	
157	76	65		01000011	43	
158	74	67		01000001	41	
159	73	69		01000000	40	
160	71	71		11000000	C0	
161	69	73		11000001	C1	
162	67	74		11000011	C3	
163	65	76		11000010	C2	
164	64	77		11000110	C6	
165	62	79		11000111	C7	
166	60	80		11000101	C5	
167	58	82		11000100	C4	
168	56	83		11001100	CC	
169	53	84		11001101	CD	
170	51	86		11001111	CF	
171	49	87		11001110	CE	
172	47	88		11001010	CA	
173	45	89		11001011	CB	
174	43	91		11001001	C9	
175	40	91		11001000	C8	
176	38	93		11011000	D8	
177	36	93		11011001	D9	
178	34	94		11011011	DB	
179	31	95		11011010	DA	
180	29	96		11011110	DE	
181	27	96		11011111	DF	
182	24	97		11011101	DD	
183	22	98		11011100	DC	
184	20	98		11010100	D4	
185	17	98		11010101	D5	
186	15	99		11010111	D7	
187	12	99		11010110	D6	
188	10	100		11010010	D2	
189	7	100		11010011	D3	
190	5	100		11010001	D1	
191	2	100		11010000	D0	

Step#	Output Current	Direction of Current	Output Current	Direction of Current	STEP12 STEP34	
	IS1/3[%]	OUT1/3	IS2/4[%]	OUT2/ 4	(bin)	(hex)
192	0	X	100	CCW	11110000	F0
193	2	CW	100		11110001	F1
194	5		100		11110011	F3
195	7		100		11110010	F2
196	10		100		11110110	F6
197	12		99		11110111	F7
198	15		99		11110101	F5
199	17		98		11110100	F4
200	20		98		11111100	FC
201	22		98		11111101	FD
202	24		97		11111111	FF
203	27		96		11111110	FE
204	29		96		11111010	FA
205	31		95		11111011	FB
206	34		94		11111001	F9
207	36		93		11111000	F8
208	38		93		11101000	E8
209	40		91		11101001	E9
210	43		91		11101011	EB
211	45		89		11101010	EA
212	47		88		11101110	EE
213	49		87		11101111	EF
214	51		86		11101101	ED
215	53		84		11101100	EC
216	56		83		11100100	E4
217	58		82		11100101	E5
218	60		80		11100111	E7
219	62		79		11100110	E6
220	64		77		11100010	E2
221	65		76		11100011	E3
222	67		74		11100001	E1
223	69		73		11100000	E0
224	71		71	10100000	A0	
225	73	69	10100001	A1		
226	74	67	10100011	A3		
227	76	65	10100010	A2		
228	77	64	10100110	A6		
229	79	62	10100111	A7		
230	80	60	10100101	A5		
231	82	58	10100100	A4		
232	83	56	10101100	AC		
233	84	53	10101101	AD		
234	86	51	10101111	AF		
235	87	49	10101110	AE		
236	88	47	10101010	AA		
237	89	45	10101011	AB		
238	91	43	10101001	A9		
239	91	40	10101000	A8		
240	93	38	10111000	B8		
241	93	36	10111001	B9		
242	94	34	10111011	BB		
243	95	31	10111010	BA		
244	96	29	10111110	BE		
245	96	27	10111111	BF		
246	97	24	10111101	BD		
247	98	22	10111100	BC		
248	98	20	10110100	B4		
249	98	17	10110101	B5		
250	99	15	10110111	B7		
251	99	12	10110110	B6		
252	100	10	10110010	B2		
253	100	7	10110011	B3		
254	100	5	10110001	B1		
255	100	2	10110000	B0		

■ SPI Interface

1. Data Writing and Reading Modes on Every Address

Internal registers are written by using 4-wire serial interface pins (CSN, SCK, SDI and SDO). The data on this interface consists of Register address (MSB first, 7bits), Read/Write and Control data or Output data (MSB first, 8bits). Address and data is clocked in on the rising edge of SCK and data is clocked out on the falling edge. Data writings become available on the rising edge of 16th falling edge of SCK. When reading the data, the SDO pin outputs data in D7-D0 at the falling edge of 8th SCK. Clock speed of SCK is 2MHz (max). In write mode, after recognizing D0 by “↑” of SCK, CSN have to be set “L” → “H”.

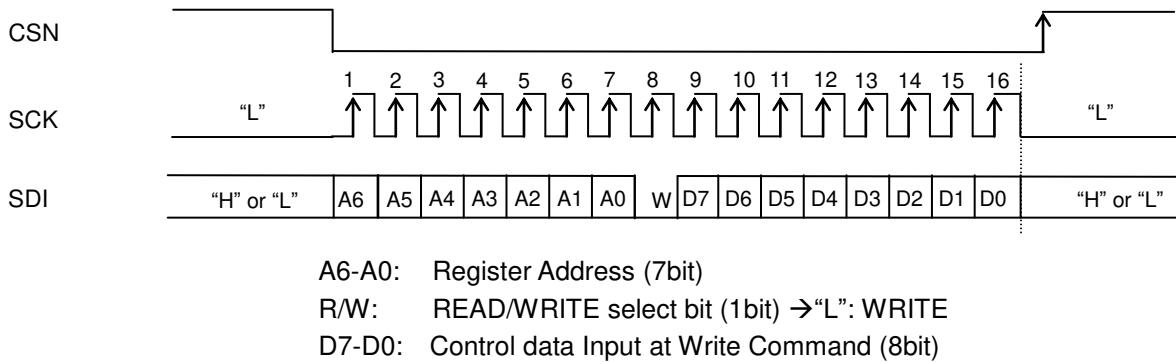

Figure 4. Serial Control Interface Timing (write mode)

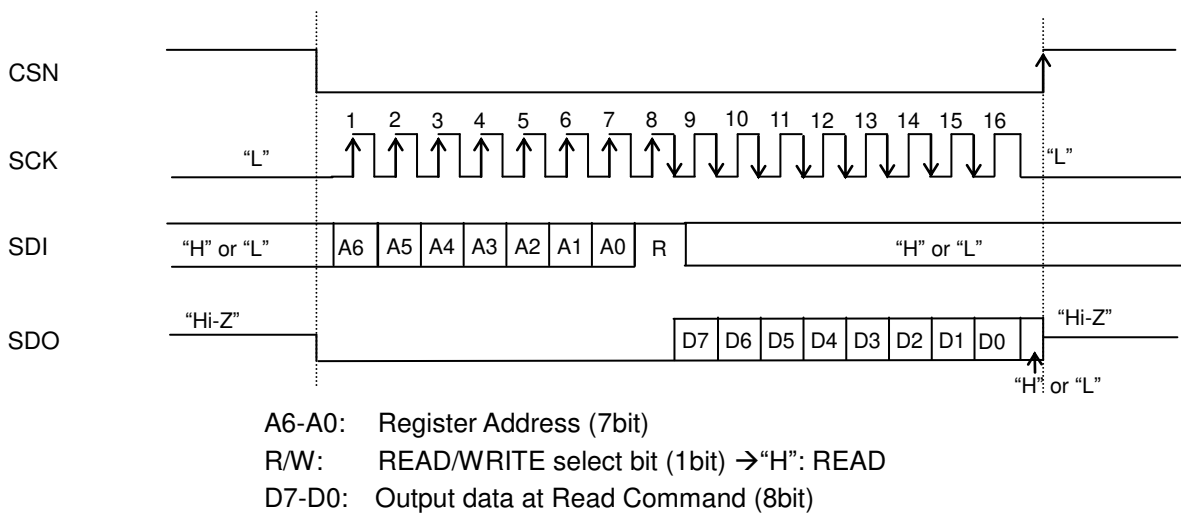

Figure 5. Serial Control Interface Timing (read mode)

2. Continuous Data Writing and Reading Mode

Address is incremented automatically and data is written continuously. When the written address or the read-out address reaches 03H, it is automatically incremented to 00H.

In this mode, registers are written by 4-wire serial interface pins (CSN, SCK, SDI and SDO). The data on the 4-wire serial interface is 8 bit data, consisting of register address (MSB-first, 7bits), Read/Write and control or output data (MSB-first, 8xN bits). The receiving data is latched on a rising edge (“↑”) of SCK. The first write data becomes effective between the rising edge (“↑”) and the falling edge (“↓”) of 16th SCK. When the micro-processor continues sending SDI and SCK clocks while the CSN pin = “L”, the address counter is incremented automatically and writing data becomes effective between the rising edge (“↑”) and the falling edge (“↓”) of every 8th SCK. For the last address, writing data becomes effective between the rising edge (“↑”) of 8th SCK.

Similarly, in the case of read-out mode, when the micro-processor continues sending SCK clocks while the CSN pin = “L” the address counter is incremented automatically and the data output from SDO at the falling edge (“↓”) of SCK continuously. The clock speed of SCK is 2MHz (max).

Even through the writing data does not reach the last address; a write or read-out command can be completed when the CSN pin is set to “H” as long as SCK is continuing being inputted.

When CSN “↑” was written before “↑” of 8th SCK in continuous data writing mode, the previous data writing address becomes valid and the writing address is ignored.

After 8bits data in the last address became valid, put the CSN pin “H” to complete the write command. If the SDI and SCK inputs are continued when the CSN pin = “L”, the data in the next address, which is incremented, is over written.

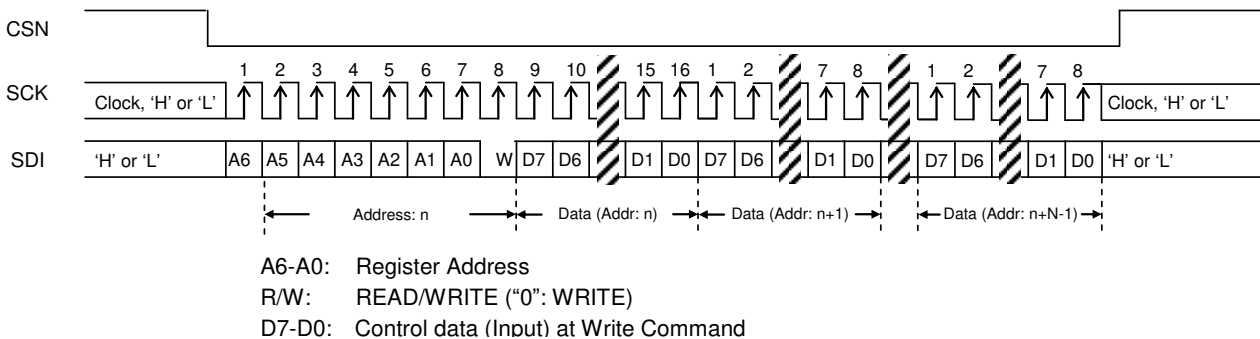

Figure 6. Serial Control Interface Timing (Continuous Writing Mode)

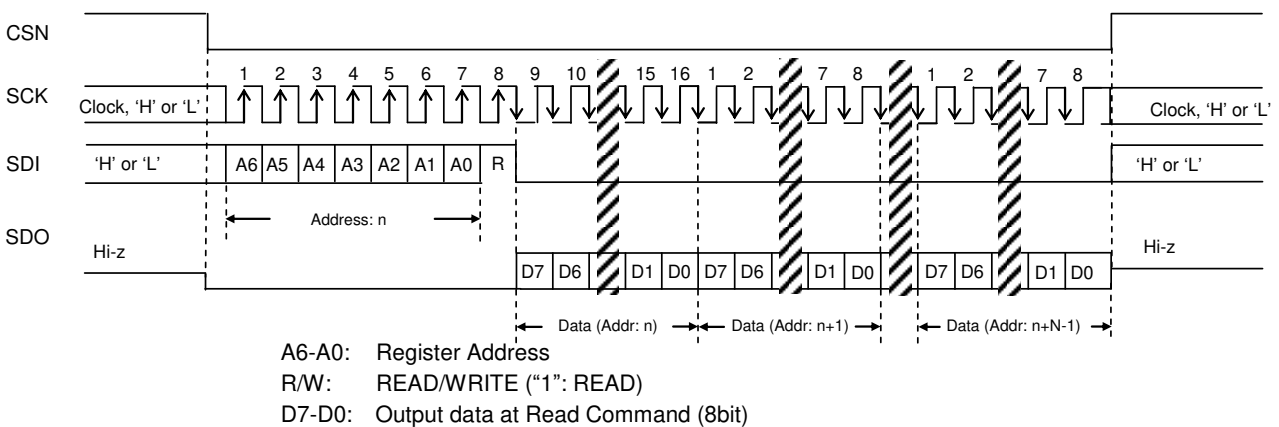

Figure 7. Serial Control Interface Timing (Continuous Reading Mode)

•DC characteristics

Table 2. (Ta = 25°C; VM = 2.0 ~ 24V, VC = 3.0 ~ 5.5V, unless otherwise specified.)

Parameter	Symbol	min	typ	max	Unit
Serial μ P Interface (SDI, SDO, SCK pins)					
High-Level Input Voltage	VIH	0.7xVC	-	-	V
Low-Level Input Voltage	VIL	-	-	0.3xVC	V
Serial μ P Interface (SDO pins Output)					
High-Level Output Voltage (Iout = -80 μ A)	VOH	VC-0.2	-	-	V
Low-Level Output Voltage (Iout = 80 μ A)	VOL	-	-	0.2	V

•Switching characteristics

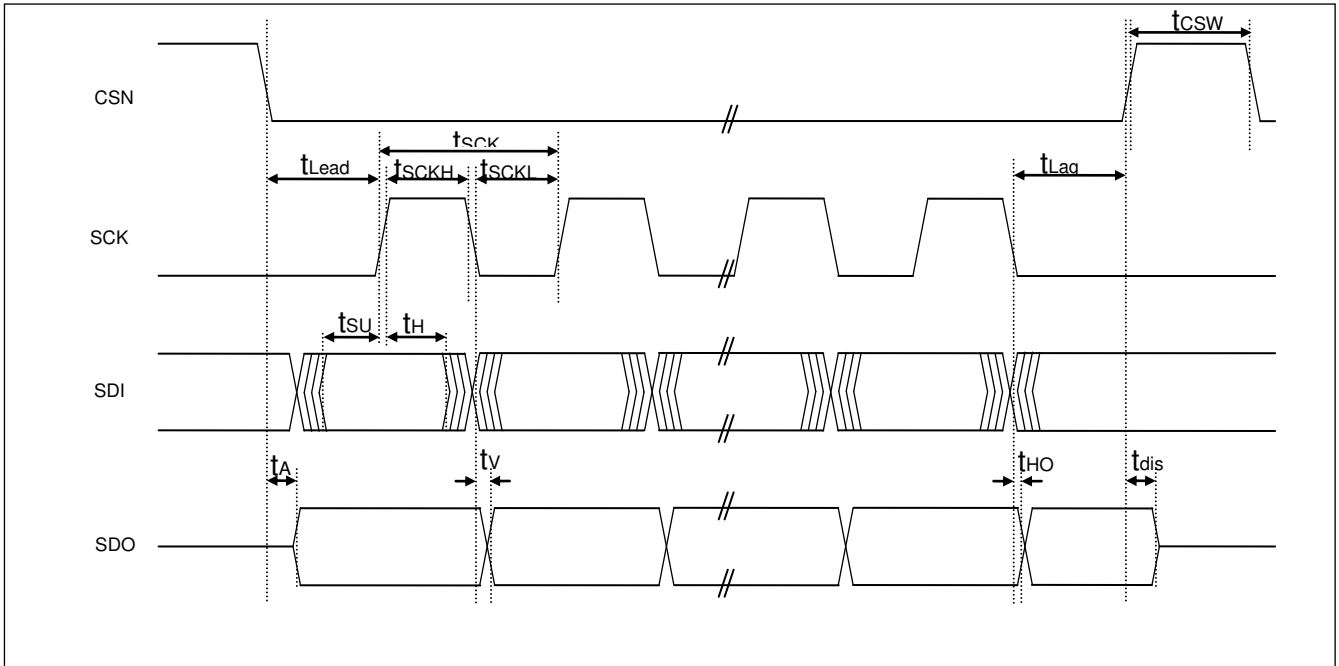

Table 3.

Parameter	Symbol	min	typ	max	Unit
Control Interface Timing					
SCK Period	tSCK	500	-	-	ns
SCK Pulse Width Low	tSCKL	200	-	-	ns
SCK Pulse Width High	tSCKH	200	-	-	ns
SDI Setup Time	tSU	100	-	-	ns
SDI Hold Time	tH	100	-	-	ns
CSN "H" Time	tCSW	375	-	-	ns
Enable Lead Time	tLead	250	-	-	ns
CSN "↓" Edge to SCK "↑"					
Enable Lag Time	tLag	250	-	-	ns
SCK "↓" to CSN "↑" Edge					
Access Time	tA	0	-	120	ns
Data Valid					
SCK "↓" to SDO (at Read Command)	tV	-	-	240	ns
Data Hold Time	tHO	0	-	-	ns
Disable Time					
CSN "↑" to SDO (Hi-Z) (at Read Command)	tdis	-	-	240	ns

■ Register map

Register Name	Addr								
		7	6	5	4	3	2	1	0
STEP12	00H	STEP12[7:0]							
STEP34	01H	STEP34[7:0]							
OECTL	02H	Reserved						OE34	OE12
OECNFG	03H	Reserved							SELOE

Resister spaces are four bytes of 03H from 00H. It is inhibit to write the address exceeding 03H.

■ Register Description

Address : 00H								
	7	6	5	4	3	2	1	0
R	STEP12[7:0]							
W								
default	0	0	0	0	0	0	0	0

BIT	Field	R/W	Description
7-0	STEP12[7:0]	R/W	The step of Motor Driver 1 & 2 Setting. According to the STEP value set up by this register, OUT1A, OUT1B, OUT2A, OUT2B, IS1, and IS2 are outputted.

Address : 01H								
	7	6	5	4	3	2	1	0
R	STEP34[7:0]							
W								
default	0	0	0	0	0	0	0	0

BIT	Field	R/W	Description
7-0	STEP34[7:0]	R/W	The step of Motor Driver 3 & 4 Setting. According to the STEP value set up by this register, OUT3A, OUT3B, OUT4A, OUT4B, IS3, and IS4 are outputted.

Address : 02H								
	7	6	5	4	3	2	1	0
R	Reserved						OE34	OE12
W								
default	0	0	0	0	0	0	0	0

BIT	Field	R/W	Description
7-2	Reserved	R	Reserved
1	OE34	R/W	The Output Enable Of Motor Driver 3 & 4 Setting. 0: Motor Driver3/4 Output Disable 1: Motor Driver3/4 Output Enable
0	OE12	R/W	The Output Enable Of Motor Driver 1 & 2 Setting. 0: Motor Driver1/2 Output Disable 1: Motor Driver1/2 Output Enable

Address : 03H								
	7	6	5	4	3	2	1	0
R	Reserved						SELOE	
W								
default	0	0	0	0	0	0	0	0

BIT	Field	R/W	Description
7-2	Reserved	R	Reserved
0	SELOE	R/W	The bit which chooses whether Enable setup is carried out to register control or pin control. 0: OE12, OE34 bit register control 1: OE12, OE34 pin control

• Current operation

1. Current operation image

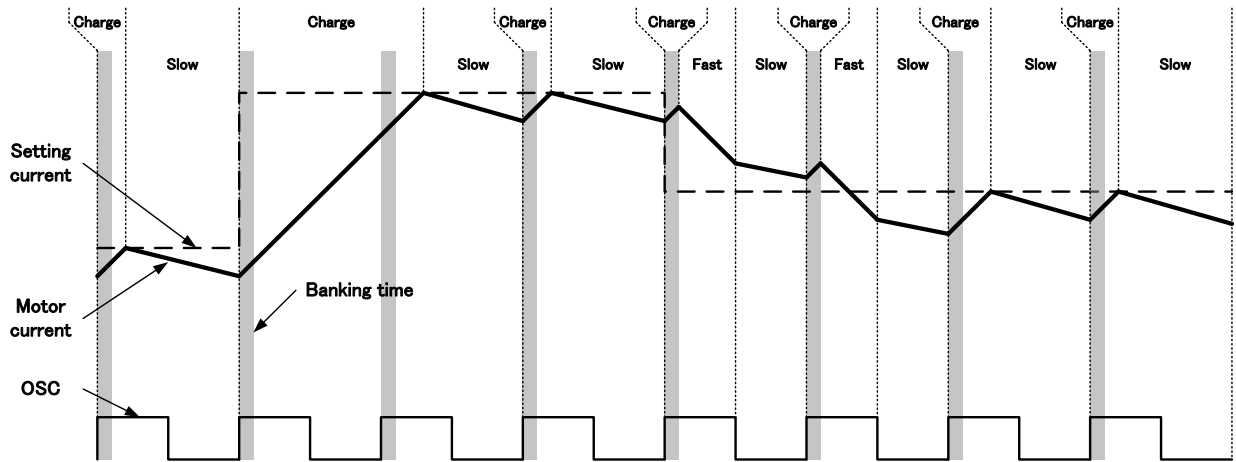

2. Current of decay mode

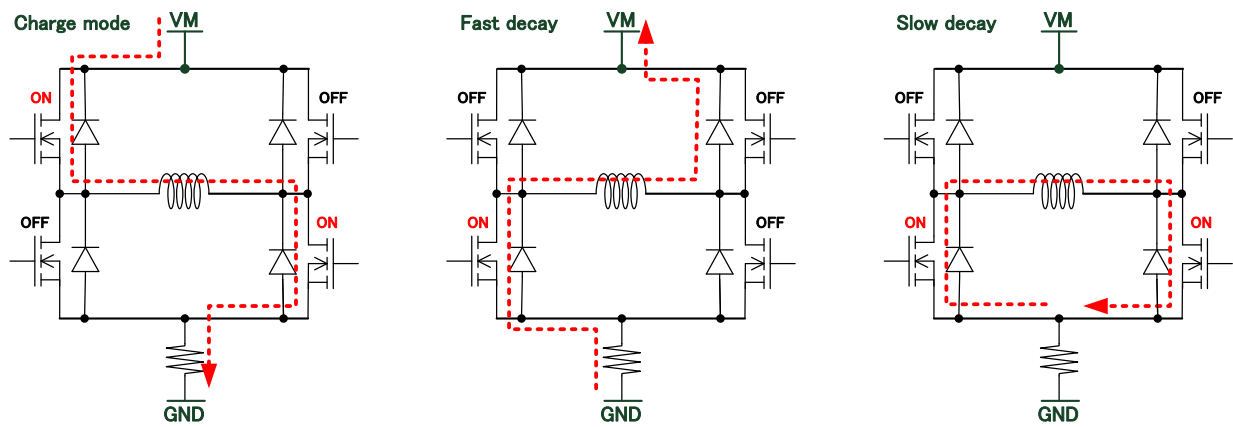

11. Recommended External Circuits

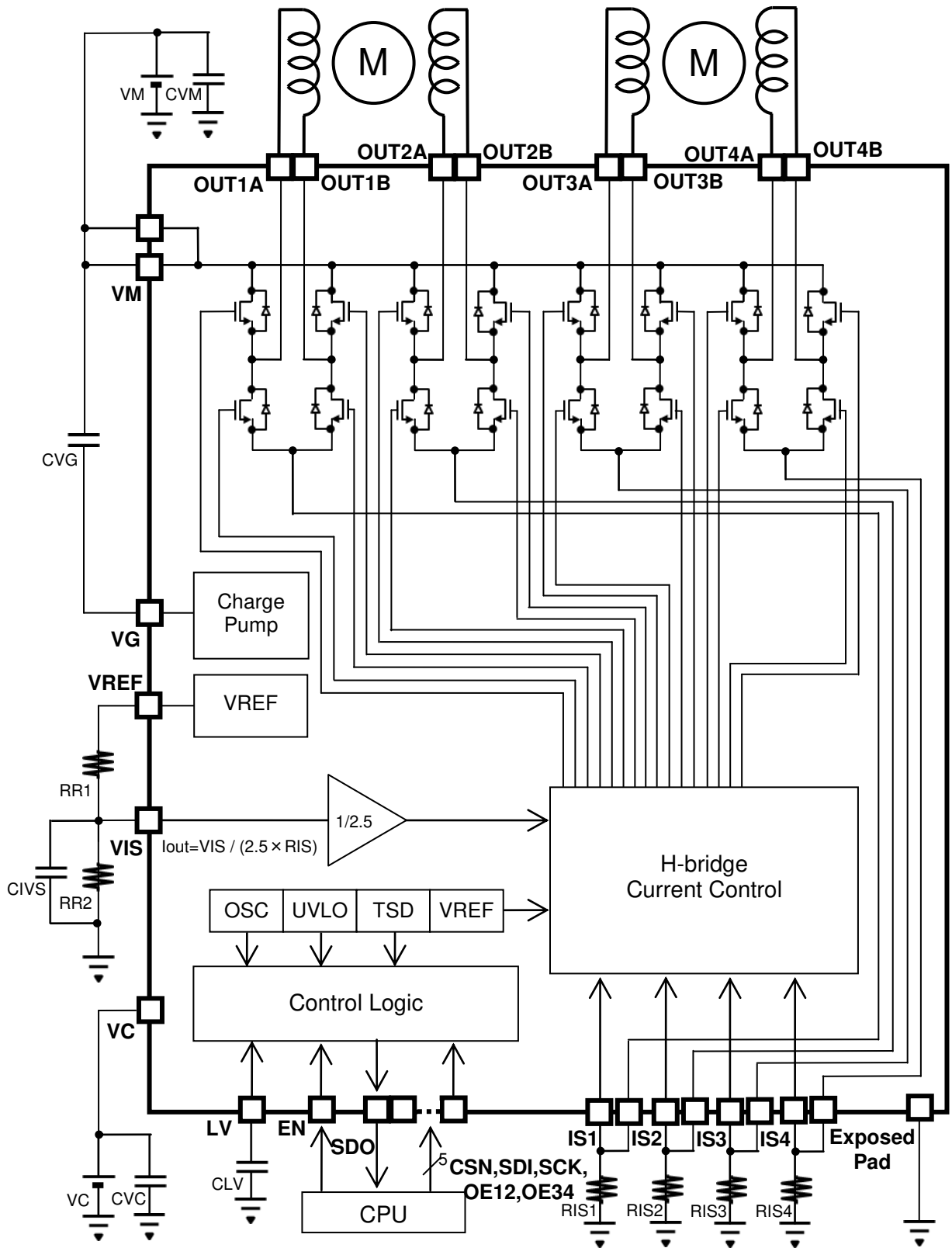

Figure 8. Recommended External Circuit

Table 4. Recommended external components example

Items	min	typ	max	Unit	Remark
CVM	-	47	-	μF	Electrolytic condenser
	-	1	-	μF	Ceramic condenser
CVC	-	1.0	-	μF	
CVG	4.7	100	150	nF	
CLV	0.68	1.0	1.5	μF	
CVIS	-	1.0	-	μF	
RISn	-	500	-	m Ω	
RR1	-	12	-	k Ω	
RR2	-	47	-	k Ω	

Note 13. Above capacitance is an example. Please choose the best external capacitors of CVM, CVC and CVG for the customers' application boards by depending on the load current profile, the load capacitance, the line resistance and etc.

12. Package

■ **Outline Dimensions**

• 32-pin QFN(Unit: mm)

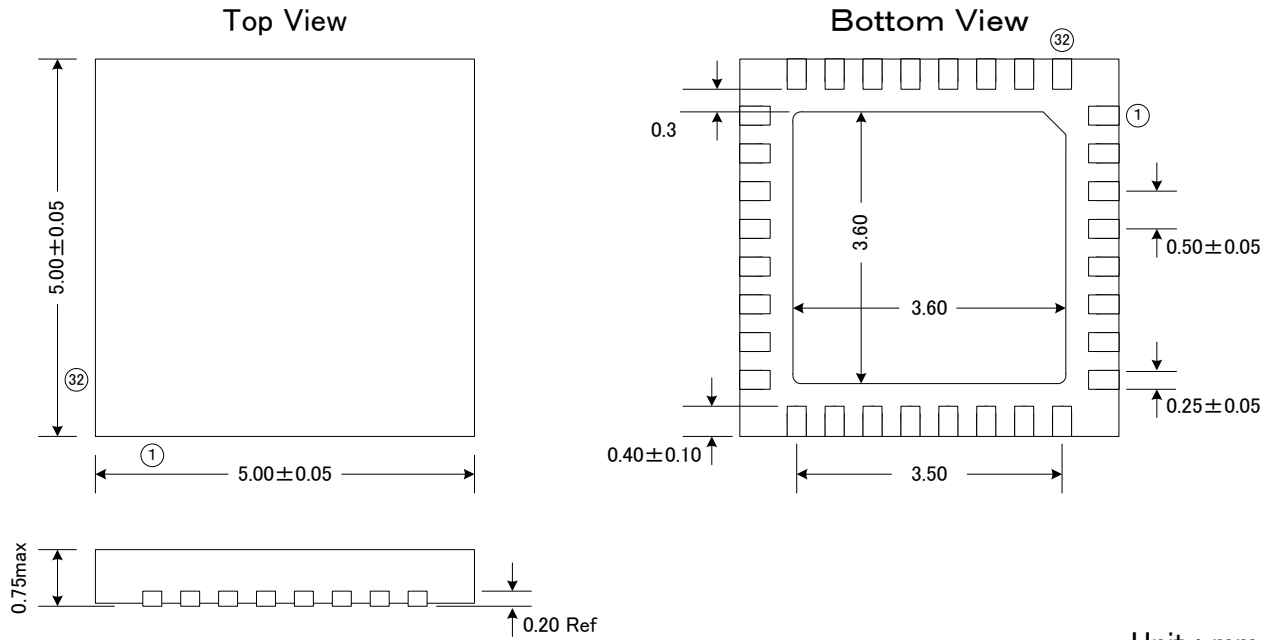

Unit : mm

■ **Marking**

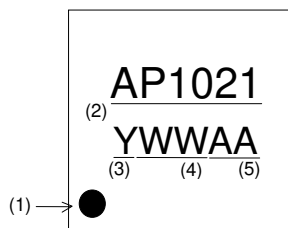

- (1) 1pin Description
- (2) Product Name "AP1021"
- (3) Year Code (last 1 digit)
- (4) Week Code
- (5) Management Code

13. Revise History

Date (YY/MM/DD)	Revision	Page	Contents
15/01/09	00	-	First Edition

IMPORTANT NOTICE

0. Asahi Kasei Microdevices Corporation (“AKM”) reserves the right to make changes to the information contained in this document without notice. When you consider any use or application of AKM product stipulated in this document (“Product”), please make inquiries the sales office of AKM or authorized distributors as to current status of the Products.
1. All information included in this document are provided only to illustrate the operation and application examples of AKM Products. AKM neither makes warranties or representations with respect to the accuracy or completeness of the information contained in this document nor grants any license to any intellectual property rights or any other rights of AKM or any third party with respect to the information in this document. You are fully responsible for use of such information contained in this document in your product design or applications. **AKM ASSUMES NO LIABILITY FOR ANY LOSSES INCURRED BY YOU OR THIRD PARTIES ARISING FROM THE USE OF SUCH INFORMATION IN YOUR PRODUCT DESIGN OR APPLICATIONS.**
2. The Product is neither intended nor warranted for use in equipment or systems that require extraordinarily high levels of quality and/or reliability and/or a malfunction or failure of which may cause loss of human life, bodily injury, serious property damage or serious public impact, including but not limited to, equipment used in nuclear facilities, equipment used in the aerospace industry, medical equipment, equipment used for automobiles, trains, ships and other transportation, traffic signaling equipment, equipment used to control combustions or explosions, safety devices, elevators and escalators, devices related to electric power, and equipment used in finance-related fields. Do not use Product for the above use unless specifically agreed by AKM in writing.
3. Though AKM works continually to improve the Product’s quality and reliability, you are responsible for complying with safety standards and for providing adequate designs and safeguards for your hardware, software and systems which minimize risk and avoid situations in which a malfunction or failure of the Product could cause loss of human life, bodily injury or damage to property, including data loss or corruption.
4. Do not use or otherwise make available the Product or related technology or any information contained in this document for any military purposes, including without limitation, for the design, development, use, stockpiling or manufacturing of nuclear, chemical, or biological weapons or missile technology products (mass destruction weapons). When exporting the Products or related technology or any information contained in this document, you should comply with the applicable export control laws and regulations and follow the procedures required by such laws and regulations. The Products and related technology may not be used for or incorporated into any products or systems whose manufacture, use, or sale is prohibited under any applicable domestic or foreign laws or regulations.
5. Please contact AKM sales representative for details as to environmental matters such as the RoHS compatibility of the Product. Please use the Product in compliance with all applicable laws and regulations that regulate the inclusion or use of controlled substances, including without limitation, the EU RoHS Directive. AKM assumes no liability for damages or losses occurring as a result of noncompliance with applicable laws and regulations.
6. Resale of the Product with provisions different from the statement and/or technical features set forth in this document shall immediately void any warranty granted by AKM for the Product and shall not create or extend in any manner whatsoever, any liability of AKM.
7. This document may not be reproduced or duplicated, in any form, in whole or in part, without prior written consent of AKM.