



## Features

- ESD Protect for 1 Line with Uni-directional.
- Provide ESD protection for the protected line to IEC 61000-4-2 (ESD)  $\pm 25\text{kV}$  (air),  $\pm 15\text{kV}$  (contact)  
IEC 61000-4-4 (EFT) 40A (5/50ns)  
IEC 61000-4-5 (Lightning) 8.5A (8/20 $\mu\text{s}$ )  
Cable Discharge Event (CDE)
- Ultra-small SOD-323 package saves board space.
- Protect one I/O line or one power line
- Fast turn-on and Low clamping voltage
- Low operating voltage: 5V
- Solid-state silicon-avalanche and active circuit triggering technology.
- Green part available

## Applications

- Computer Interfaces Protection
- Microprocessors Protection
- Serial and Parallel Ports Protection
- Control Signal Lines Protection
- Power lines on PCB Protection
- Latchup Protection

## Description

AZ2215-01L is a design which includes a unidirectional surge rated clamping cell to protect one power line, or one control line, or one low speed data line in an electronic systems. The AZ2215-01L has been specifically designed to protect sensitive components which are connected to power and control lines from over-voltage damage and latch-up caused by Electrostatic Discharging (ESD), Electrical Fast Transients (EFT), Lightning, and Cable Discharge Event (CDE).

AZ2215-01L is a unique design which includes proprietary clamping cell in a single package.

During transient conditions, the proprietary clamping cell prevents over-voltage on the power line or control/data lines, protecting any downstream components.

AZ2215-01L may be used to meet the ESD immunity requirements of IEC 61000-4-2, Level 4 ( $\pm 15\text{kV}$  air,  $\pm 8\text{kV}$  contact discharge)

## Circuit Diagram / Pin Configuration

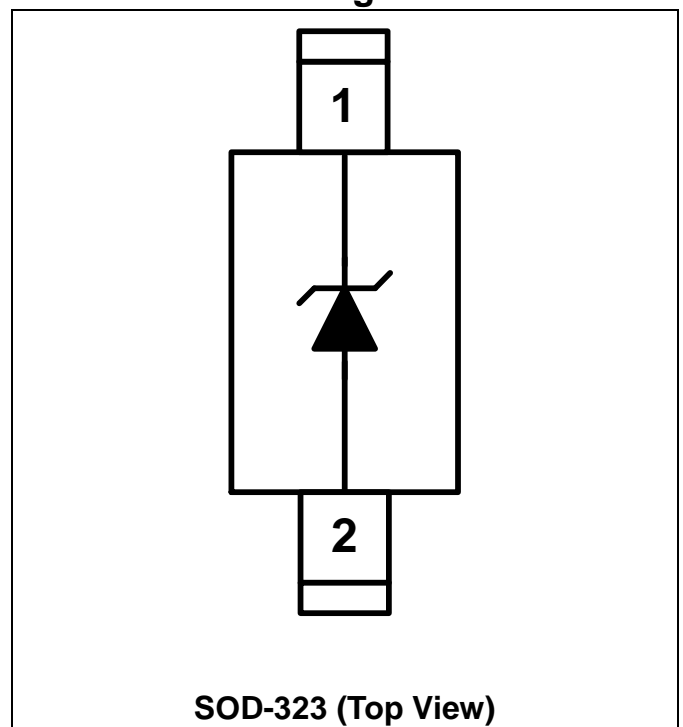



## SPECIFICATIONS

ABSOLUTE MAXIMUM RATINGS			
PARAMETER	PARAMETER	RATING	UNITS
Peak Pulse Current (tp =8/20us)	$I_{PP}$	8.5	A
Operating Supply Voltage (pin-1,-2 to pin-3)	$V_{DC}$	6	V
ESD per IEC 61000-4-2 (Air)	$V_{ESD}$	25	kV
ESD per IEC 61000-4-2 (Contact)		15	
Lead Soldering Temperature	$T_{SOL}$	260 (10 sec.)	°C
Operating Temperature	$T_{OP}$	-55 to +125	°C
Storage Temperature	$T_{STO}$	-55 to +150	°C

ELECTRICAL CHARACTERISTICS						
PARAMETER	SYMBOL	CONDITIONS	MINI	TYP	MAX	UNITS
Reverse Stand-Off Voltage	$V_{RWM}$	$T=25\text{ }^{\circ}\text{C}$ .			5	V
Reverse Leakage Current	$I_{Leak}$	$V_{RWM}=5\text{V}$ , $T=25\text{ }^{\circ}\text{C}$ .			2.5	$\mu\text{A}$
Reverse Breakdown Voltage	$V_{BV}$	$I_{BV}=1\text{mA}$ , $T=25\text{ }^{\circ}\text{C}$ .	6.1		9	V
Forward Voltage	$V_F$	$I_F=15\text{mA}$ , $T=25\text{ }^{\circ}\text{C}$	0.6	0.8	1	V
Clamping Voltage 1	$V_{CL}$	$I_{PP}=5\text{A}$ , $t_p=8/20\mu\text{s}$ , $T=25\text{ }^{\circ}\text{C}$ .		7	8	V
Clamping Voltage 2	$V_{CL}$	$I_{PP}=7\text{A}$ , $t_p=8/20\mu\text{s}$ , $T=25\text{ }^{\circ}\text{C}$ .		8	9	V
ESD Holding Voltage	$V_{hold}$	IEC 61000-4-2 6kV, $T=25\text{ }^{\circ}\text{C}$ , Contact mode.		9		V
Channel Input Capacitance	$C_{IN}$	$V_R=0\text{V}$ , $f=1\text{MHz}$ , $T=25\text{ }^{\circ}\text{C}$ .		25	30	pF



## Typical Characteristics

Pulse Waveform

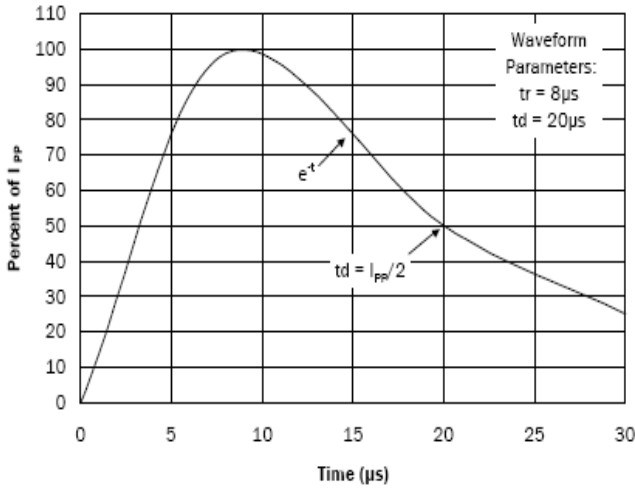

Clamping Voltage vs. Peak Pulse Current

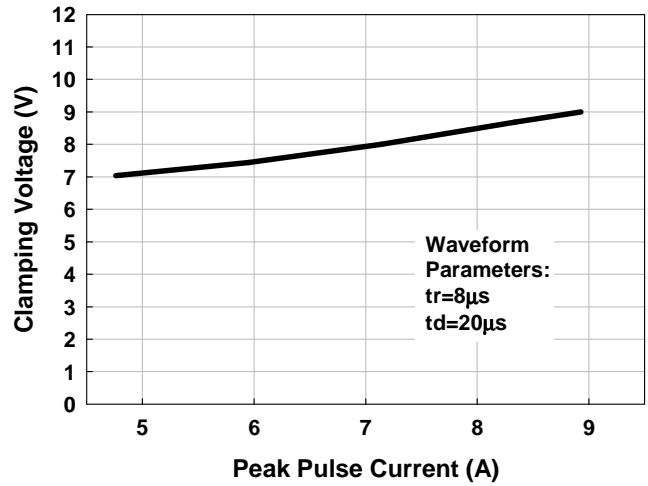

Forward Clamping Voltage vs. Peak Pulse Current

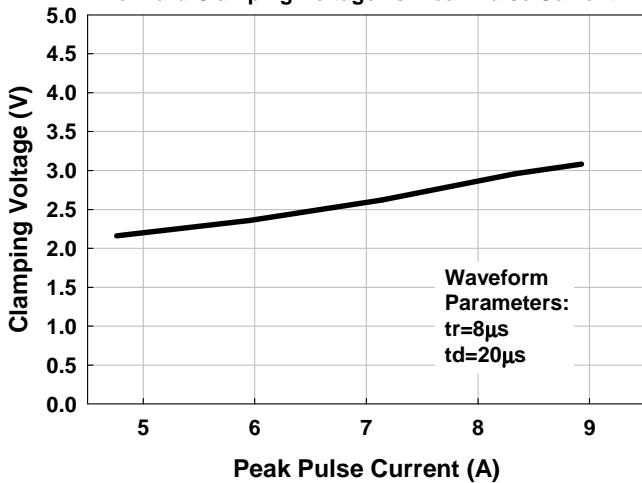

Typical Variation  $C_{IN}$  vs.  $V_{IN}$

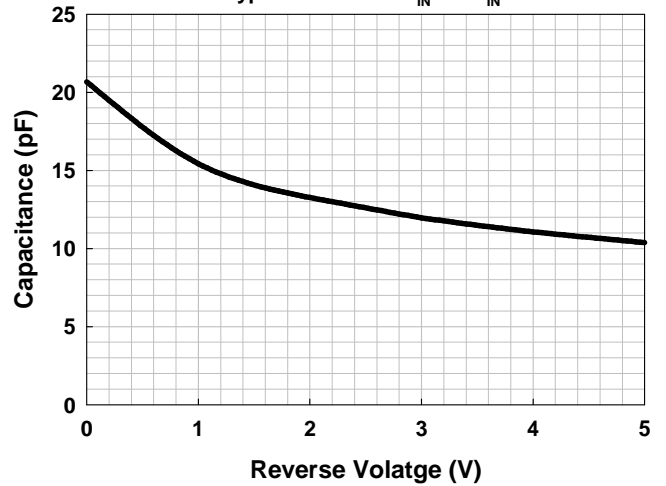

Transmission Line Pulsing (TLP) Measurement

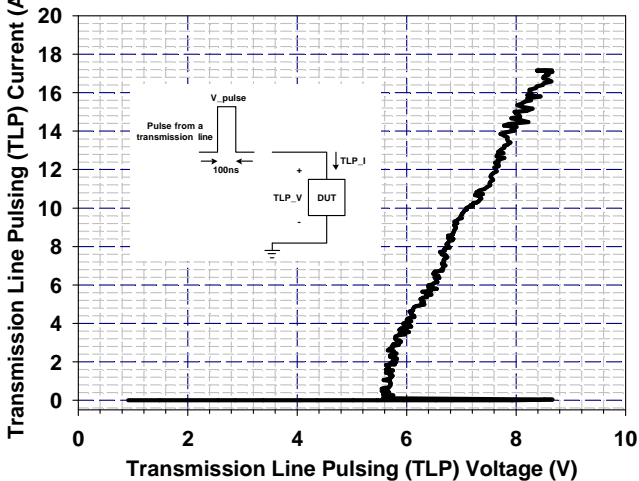

## Applications Information

The AZ2215-01L is designed to protect one line against System ESD/EFT/Lightning pulses by clamping them to an acceptable reference.

The usage of the AZ2215-01L is shown in Fig. 1. Protected lines, such as data lines, control lines, or power lines, are connected at pin 1. The pin 2 should be connected directly to a ground plane on the board. All path lengths connected to the pins of AZ2215-01L should be kept as short as possible to minimize parasitic inductance in the board traces.

In order to obtain enough suppression of ESD induced transient, good circuit board is critical.

Thus, the following guidelines are recommended:

- Minimize the path length between the protected lines and the AZ2215-01L.
- Place the AZ2215-01L near the input terminals or connectors to restrict transient coupling.
- The ESD current return path to ground should be kept as short as possible.
- Use ground planes whenever possible.
- NEVER route critical signals near board edges and near the lines which the ESD transient easily injects to.

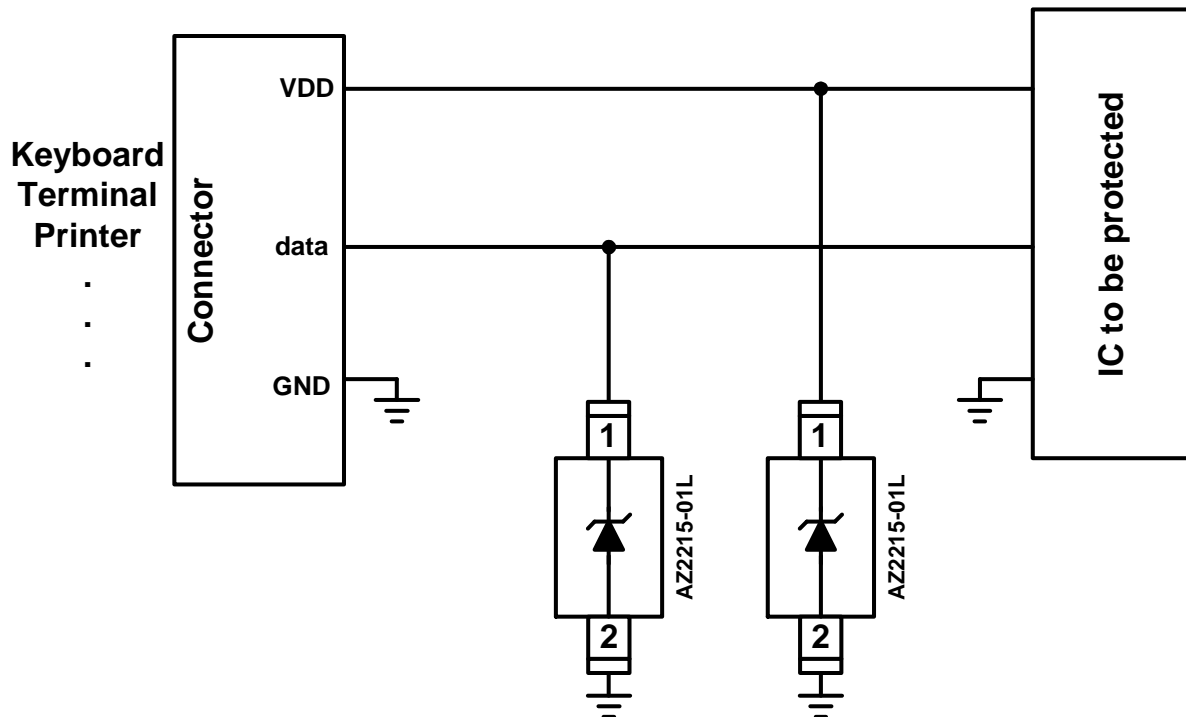

**Fig. 1**

Fig. 2 shows another simplified example of using AZ2215-01L to protect the control lines, low speed data lines, and power lines from ESD transient stress.

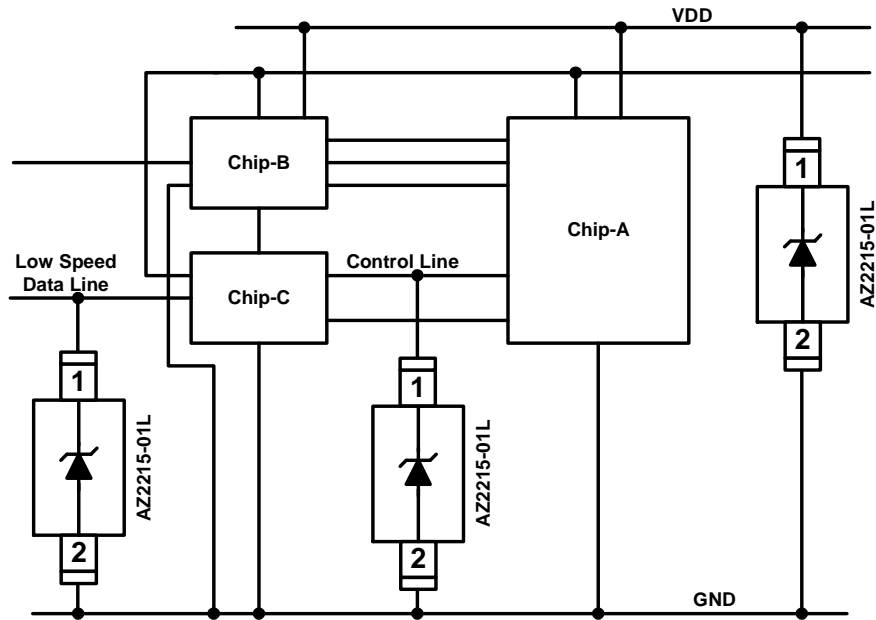

**Fig. 2**



## Mechanical Details

SOD-323

### PACKAGE DIAGRAMS

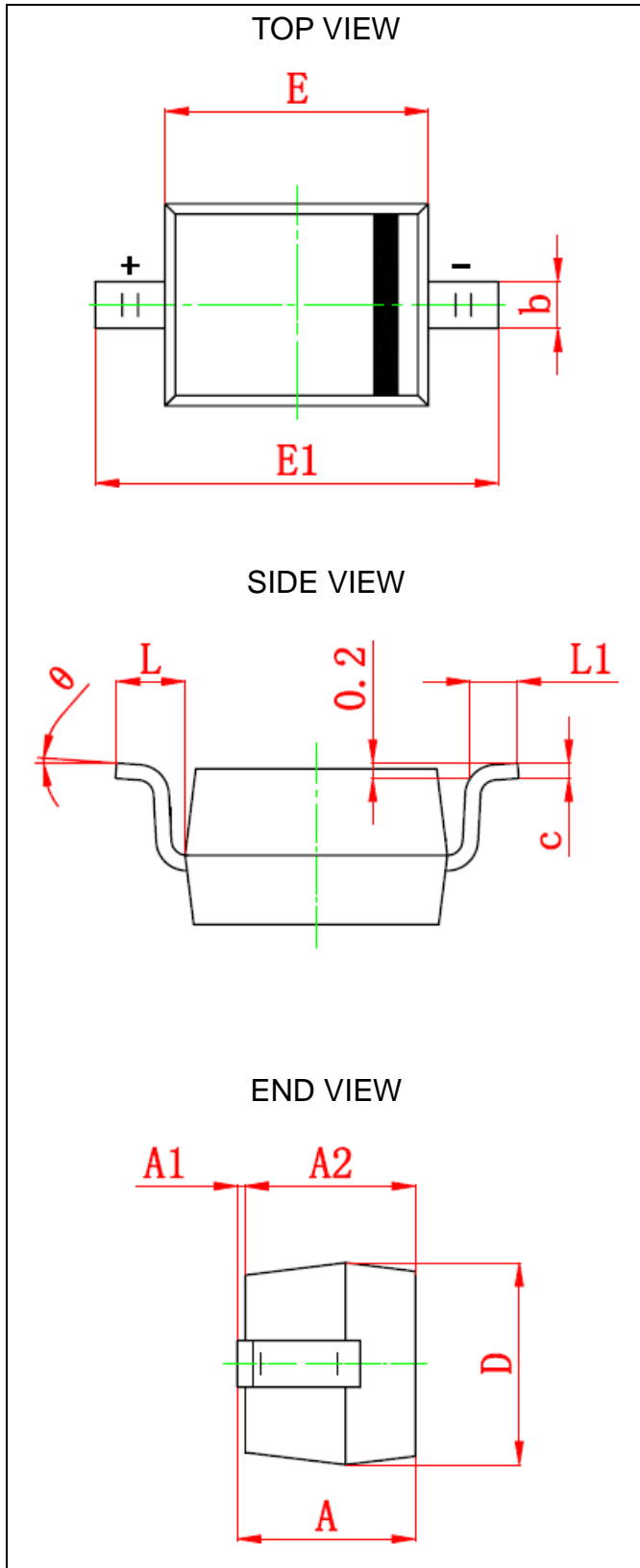

### PACKAGE DIMENSIONS

Symbol	Millimeters		Inches	
	MIN.	MAX.	MIN.	MAX.
A	0.8	1.0	0.031	0.039
A1	0	0.1	0.000	0.004
A2	0.8	0.9	0.031	0.035
b	0.25	0.35	0.010	0.014
C	0.08	0.15	0.003	0.006
D	1.2	1.4	0.047	0.055
E	1.6	1.8	0.063	0.071
E1	2.5	2.7	0.098	0.106
L	0.475REF		0.019 REF	
L1	0.25	0.4	0.010	0.016
$\theta$	0°	8°	0°	8°



## LAND LAYOUT

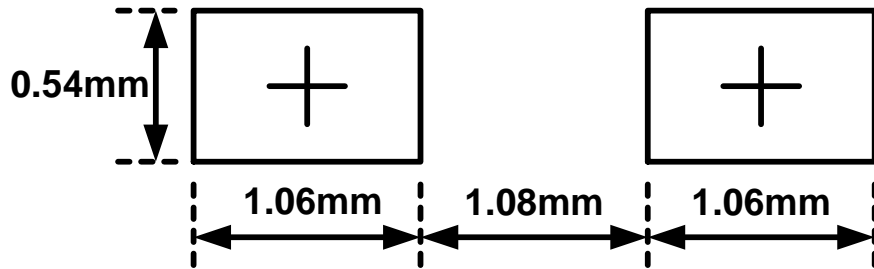

### Notes:

This LAND LAYOUT is for reference purposes only. Please consult your manufacturing partners to ensure your company's PCB design guidelines are met.

## MARKING CODE

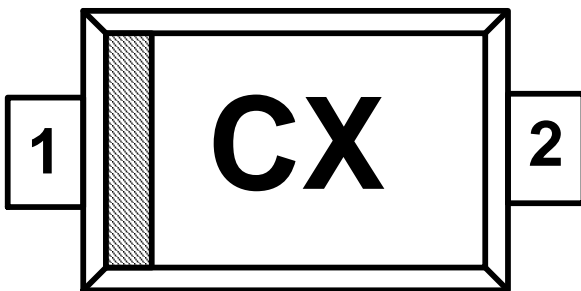

C = Device Code  
X = Date Code

Part Number	Marking Code
AZ2215-01L (Rohs part)	CX
<b>AZ2215-01L</b> <b>(Green part)</b>	<b>cX</b>

## Ordering Information

PN#	Material	Type	Reel size	MOQ/interal box	MOQ/carton
AZ2215-01L.R7G	Green	T/R	7 inch	4 reel=12,000/box	6 box=72,000/carton

## Tape and Reel Specification

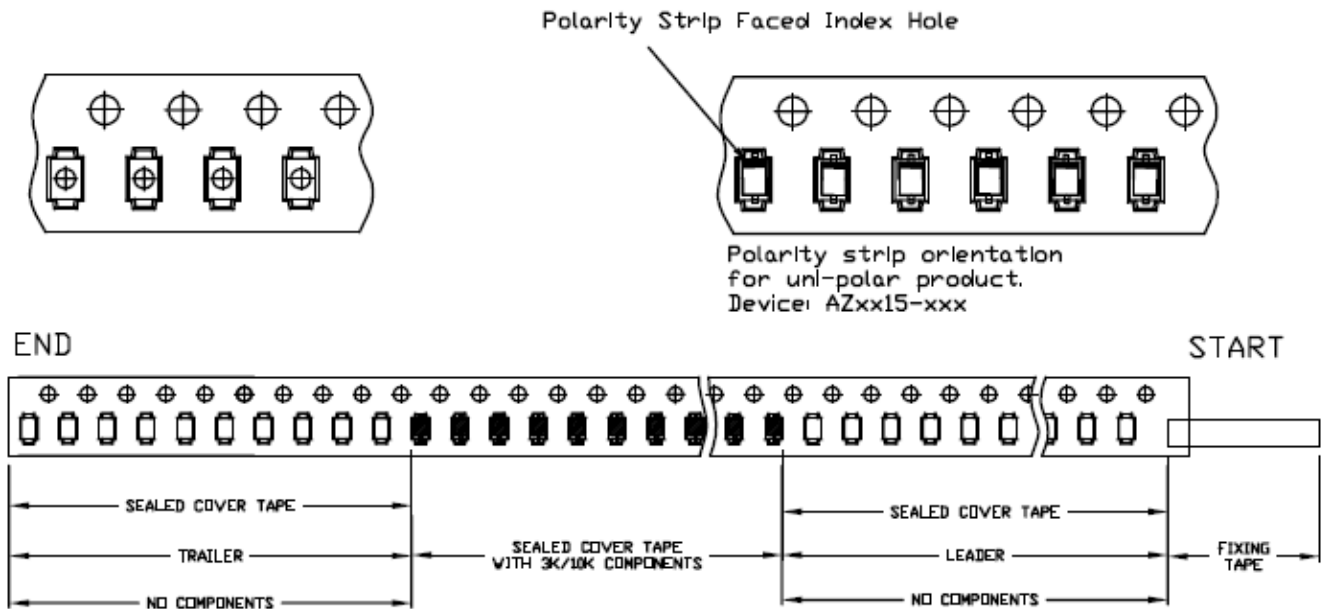

## Revision History

Revision	Modification Description
Revision 2008/08/14	Original Release.
Revision 2008/09/29	Add the marking code for Green part.
Revision 2009/12/31	Change the description of "Anode Indication" at PACKAGE DIAGRAMS to be the "Signal Pin Indication".
Revision 2010/1/11	Update the PACKAGE DIMENSIONS.
Revision 2011/06/18	1. Update the Company Logo. 2. Add the Ordering Information. 3. Update the Package Dimensions.