

NOTES:

Mechanical:

1. Housing material : Glass Filled Polyester UL94V-0 , Color: Black
2. Contact material: Phosphor Bronze t=0.35mm
3. Contact plating: Contact area---Selective gold plating
Tails---Tin plating all over 50u" Nickel
4. Operating Life: 750 Cycles min.
5. PCB Retention Pre-solder: 1 LB min.
6. PCB Retention Post-solder: 10 LBS min.

Electrical:

1. Voltage Rating: 125VAC.
2. Current Rating: 1.5AMP.
3. Contact Resistance: 30mΩ max.
4. Insulation Resistance: 1000MΩ min. @ 500 VDC
5. Dielectric Strength: 750 VAC 50Hz, 1 min.

Environmental:

1. Storage: -40°C To +85°C
 2. Operation: -40°C~+85°C
 3. Wave Soldering Temp: 200~220°C(5~10S)
- Packing: 100pcs/Tray, 3200pcs/Carton

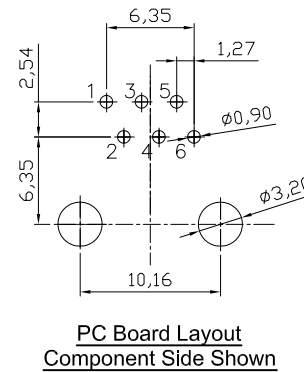
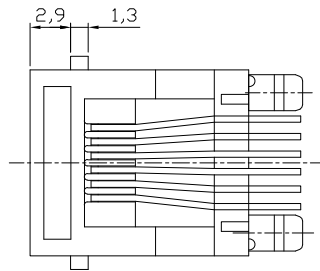
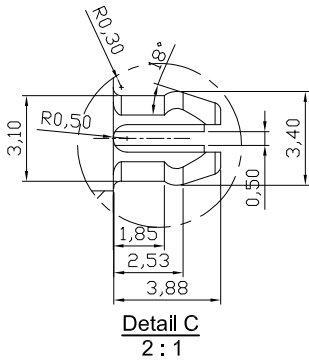

Order code: A-2014-1-X

- Contact plating:
1: selective 15u" gold
2: selective 30u" gold
3: selective 50u" gold

RoHS compliant
Unit:mm

Scale	Free						Date	Name	Customer-No.
TOLERANCE						Drawn	27.05.2013	Amy	
X.X	±0.20					Approved	27.05.2013	Amy	
X.XX	±0.15								
X.XXX	±0.10								
DIM	TOL								Drawing-No.
									A-2014-1-X
		①	Drawn	27.05.2013	Amy	ASSMANN WVSW components		ASS 5703 CO	rev00
Angle	±5°	Id.	Modification	Date	Name			Replace	SHEET



ASS 5703 CO rev00
Replace SHEET