

# TIP47, TIP48, TIP49, TIP50 NPN SILICON POWER TRANSISTORS

**BOURNS®**

- 40 W at 25°C Case Temperature
- 1 A Continuous Collector Current
- 2 A Peak Collector Current
- 20 mJ Reverse-Energy Rating



This series is obsolete and not recommended for new designs.

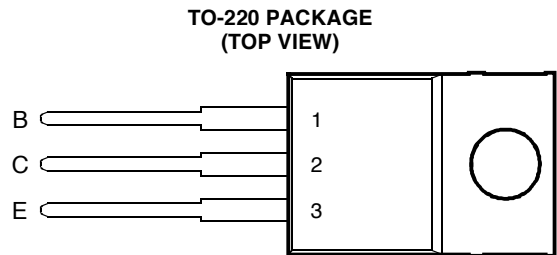

Pin 2 is in electrical contact with the mounting base.

MDTRACA

## absolute maximum ratings at 25°C case temperature (unless otherwise noted)

RATING		SYMBOL	VALUE	UNIT
Collector-base voltage ( $I_E = 0$ )	TIP47	$V_{CB0}$	350	V
	TIP48		400	
	TIP49		450	
	TIP50		500	
Collector-emitter voltage ( $I_B = 0$ )	TIP47	$V_{CEO}$	250	V
	TIP48		300	
	TIP49		350	
	TIP50		400	
Emitter-base voltage		$V_{EBO}$	5	V
Continuous collector current		$I_C$	1	A
Peak collector current (see Note 1)		$I_{CM}$	2	A
Continuous base current		$I_B$	0.6	A
Continuous device dissipation at (or below) 25°C case temperature (see Note 2)		$P_{tot}$	40	W
Continuous device dissipation at (or below) 25°C free air temperature (see Note 3)		$P_{tot}$	2	W
Unclamped inductive load energy (see Note 4)		$\frac{1}{2}LI_C^2$	20	mJ
Operating junction temperature range		$T_j$	-65 to +150	°C
Storage temperature range		$T_{stg}$	-65 to +150	°C
Lead temperature 3.2 mm from case for 10 seconds		$T_L$	260	°C

- NOTE
- 1: This value applies for  $t_p \leq 1$  ms, duty cycle  $\leq 2\%$ .
  - 2: Derate linearly to 150°C case temperature at the rate of 0.32 W/°C.
  - 3: Derate linearly to 150°C free air temperature at the rate of 16 mW/°C.
  - 4: This rating is based on the capability of the transistor to operate safely in a circuit of:  $L = 20$  mH,  $I_{B(on)} = 0.4$  A,  $R_{BE} = 100 \Omega$ ,  $V_{BE(off)} = 0$ ,  $R_S = 0.1 \Omega$ ,  $V_{CC} = 20$  V.

## PRODUCT INFORMATION

DECEMBER 1971 - REVISED SEPTEMBER 2002  
Specifications are subject to change without notice.

**electrical characteristics at 25°C case temperature**

PARAMETER	TEST CONDITIONS			MIN	TYP	MAX	UNIT
$V_{(BR)CEO}$ Collector-emitter breakdown voltage	$I_C = 30 \text{ mA}$ (see Note 5)	$I_B = 0$	TIP47 TIP48 TIP49 TIP50	250 300 350 400			V
$I_{CES}$ Collector-emitter cut-off current	$V_{CE} = 350 \text{ V}$ $V_{CE} = 400 \text{ V}$ $V_{CE} = 450 \text{ V}$ $V_{CE} = 500 \text{ V}$	$V_{BE} = 0$ $V_{BE} = 0$ $V_{BE} = 0$ $V_{BE} = 0$	TIP47 TIP48 TIP49 TIP50			1 1 1 1	mA
$I_{CEO}$ Collector cut-off current	$V_{CE} = 150 \text{ V}$ $V_{CE} = 200 \text{ V}$ $V_{CE} = 250 \text{ V}$ $V_{CE} = 300 \text{ V}$	$I_B = 0$ $I_B = 0$ $I_B = 0$ $I_B = 0$	TIP47 TIP48 TIP49 TIP50			1 1 1 1	mA
$I_{EBO}$ Emitter cut-off current	$V_{EB} = 5 \text{ V}$	$I_C = 0$				1	mA
$h_{FE}$ Forward current transfer ratio	$V_{CE} = 10 \text{ V}$ $V_{CE} = 10 \text{ V}$	$I_C = 0.3 \text{ A}$ $I_C = 1 \text{ A}$	(see Notes 5 and 6)	30 10		150	
$V_{CE(sat)}$ Collector-emitter saturation voltage	$I_B = 0.2 \text{ A}$	$I_C = 1 \text{ A}$	(see Notes 5 and 6)			1	V
$V_{BE}$ Base-emitter voltage	$V_{CE} = 10 \text{ V}$	$I_C = 1 \text{ A}$	(see Notes 5 and 6)			1.5	V
$h_{fe}$ Small signal forward current transfer ratio	$V_{CE} = 10 \text{ V}$	$I_C = 0.2 \text{ A}$	$f = 1 \text{ kHz}$	25			
$ h_{fe} $ Small signal forward current transfer ratio	$V_{CE} = 10 \text{ V}$	$I_C = 0.2 \text{ A}$	$f = 2 \text{ MHz}$	5			

NOTES: 5. These parameters must be measured using pulse techniques,  $t_p = 300 \mu\text{s}$ , duty cycle  $\leq 2\%$ .

6. These parameters must be measured using voltage-sensing contacts, separate from the current carrying contacts.

**resistive-load-switching characteristics at 25°C case temperature**

PARAMETER	TEST CONDITIONS †			MIN	TYP	MAX	UNIT
$t_{on}$ Turn on time	$I_C = 1 \text{ A}$	$I_{B(on)} = 0.1 \text{ A}$	$I_{B(off)} = -0.1 \text{ A}$		0.2		$\mu\text{s}$
$t_{off}$ Turn off time	$V_{BE(off)} = -5 \text{ V}$	$R_L = 200 \Omega$	(see Figures 1 and 2)		2		$\mu\text{s}$

† Voltage and current values shown are nominal; exact values vary slightly with transistor parameters.

**PARAMETER MEASUREMENT INFORMATION**

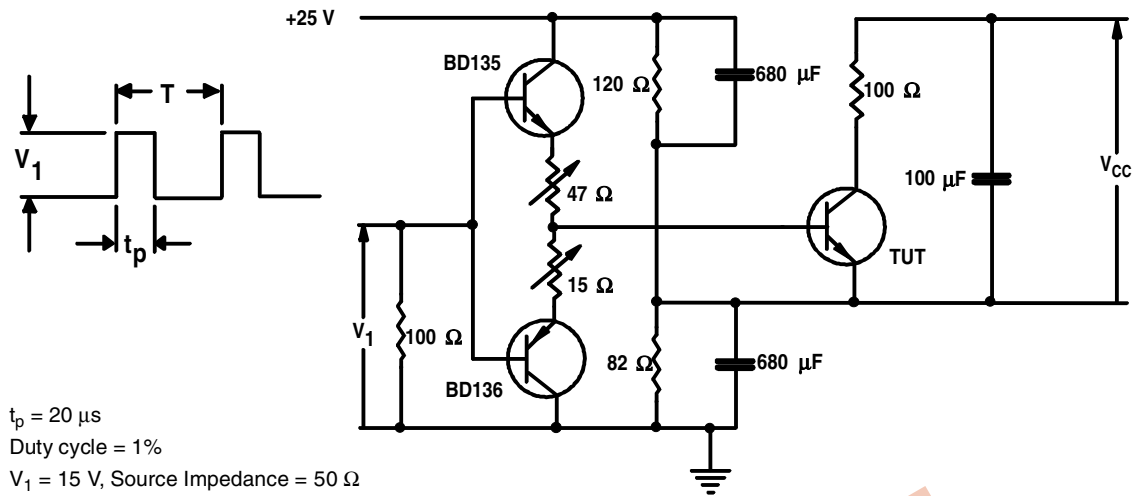

**Figure 1. Resistive-Load Switching Test Circuit**

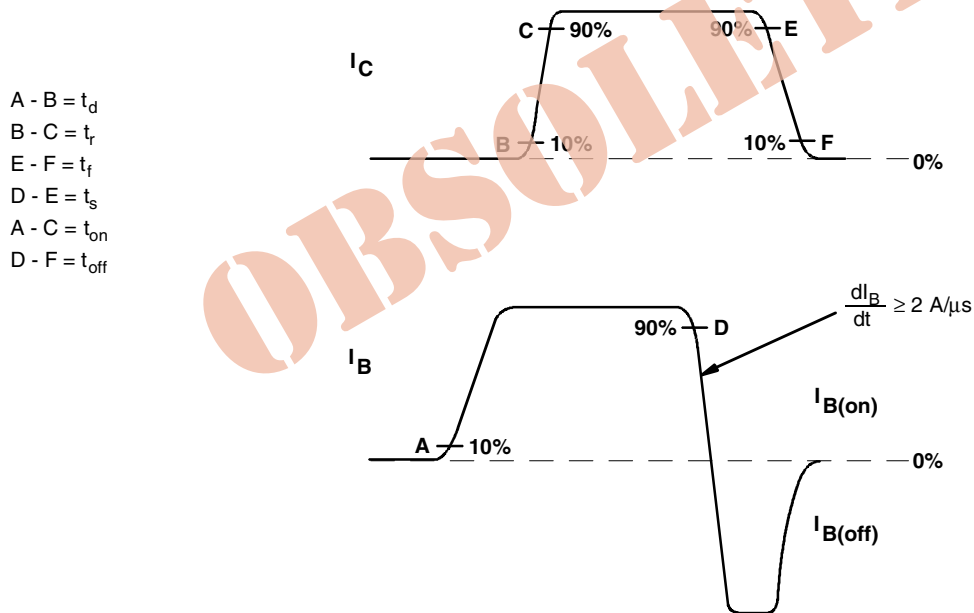

**Figure 2. Resistive-Load Switching Waveforms**

**PRODUCT INFORMATION**

DECEMBER 1971 - REVISED SEPTEMBER 2002  
 Specifications are subject to change without notice.

**TYPICAL CHARACTERISTICS**

**TYPICAL DC CURRENT GAIN  
VS  
COLLECTOR CURRENT**

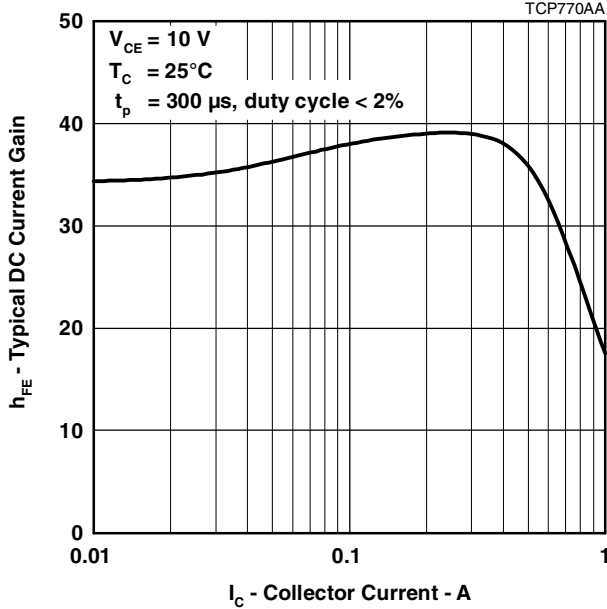

Figure 3.

**COLLECTOR-EMITTER SATURATION VOLTAGE  
VS  
COLLECTOR CURRENT**

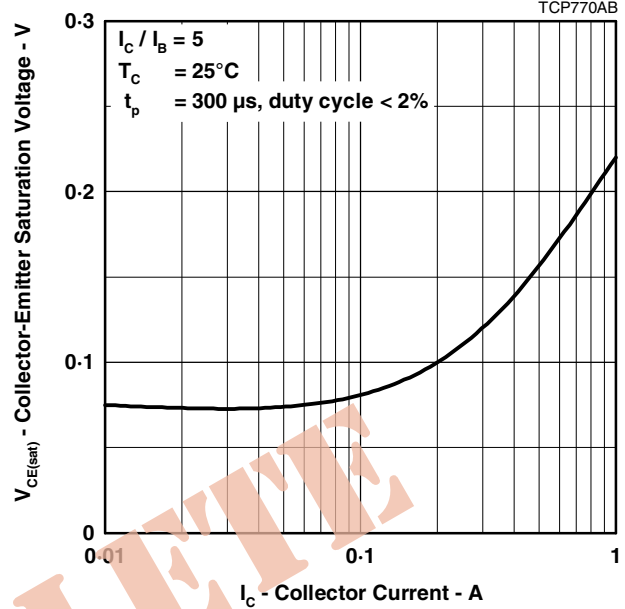

Figure 4.

**BASE-EMITTER SATURATION VOLTAGE  
VS  
COLLECTOR CURRENT**

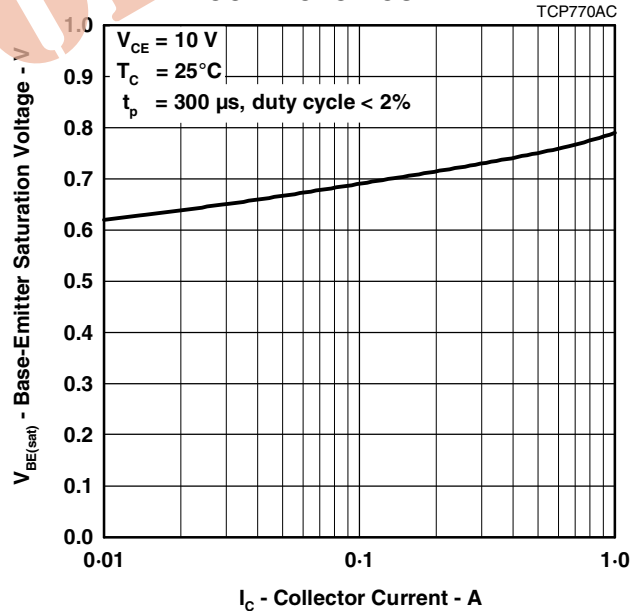

Figure 5.

**PRODUCT INFORMATION**

DECEMBER 1971 - REVISED SEPTEMBER 2002  
Specifications are subject to change without notice.

**MAXIMUM SAFE OPERATING REGIONS**

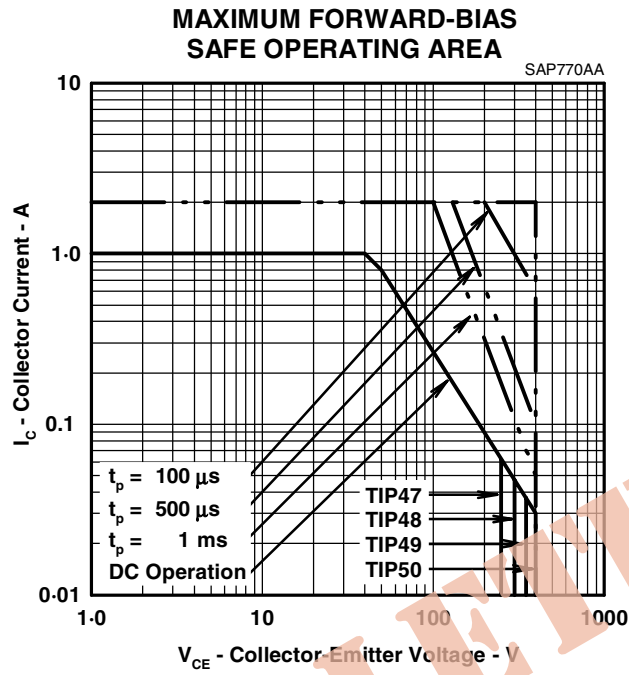

Figure 6.

**PRODUCT INFORMATION**

DECEMBER 1971 - REVISED SEPTEMBER 2002  
 Specifications are subject to change without notice.