

| REVISIONS | | | | |
|-----------|---------------------------|-----------|--------|--|
| REV | DESCRIPTION, ECN, EAR NO. | DATE | APP'D | |
| A | PROPOSAL | APR 2/18 | L.CHAN | |
| B | PROPOSAL | JAN 15/19 | L.CHAN | |
| C | PROPOSAL | OCT 22/20 | L.CHAN | |

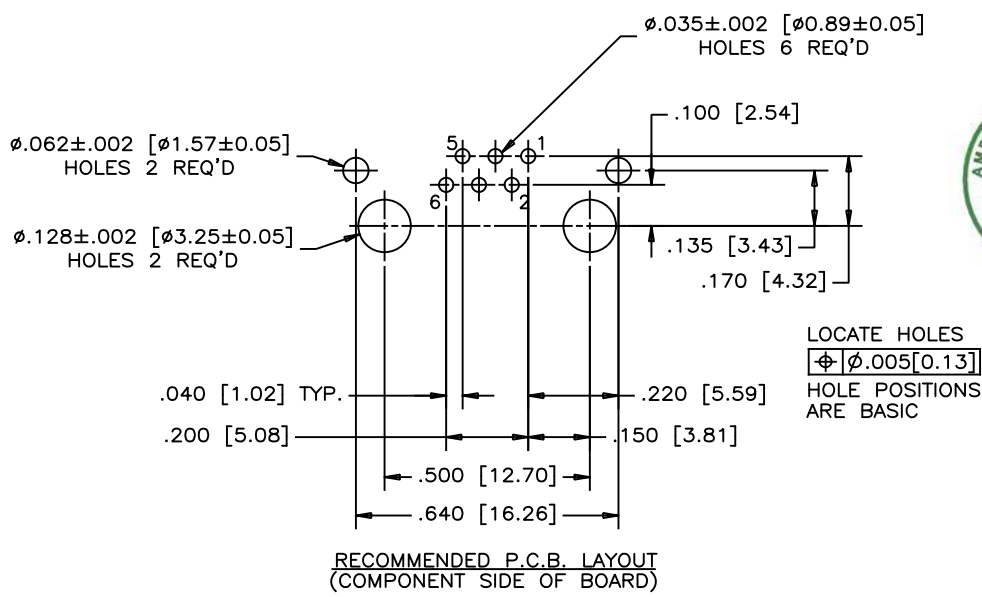
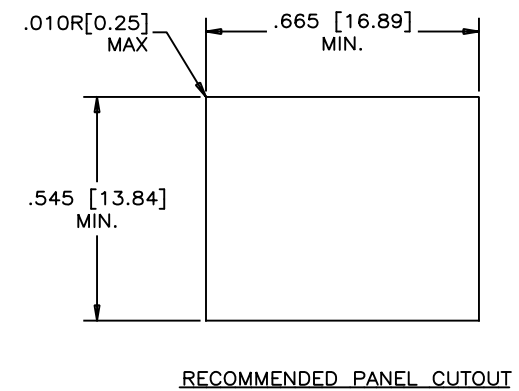
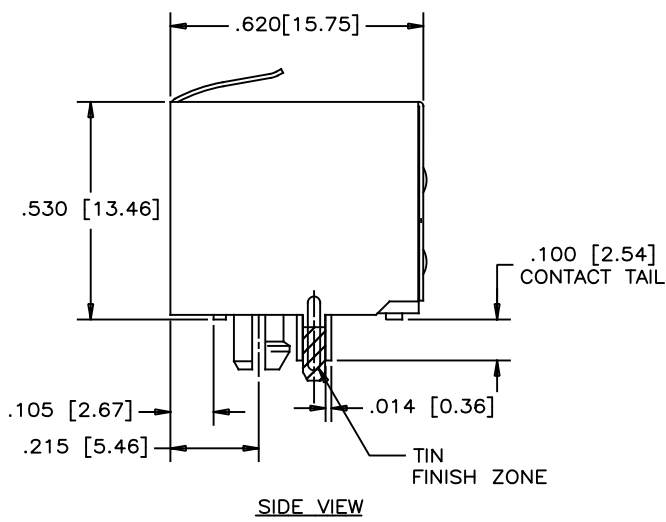
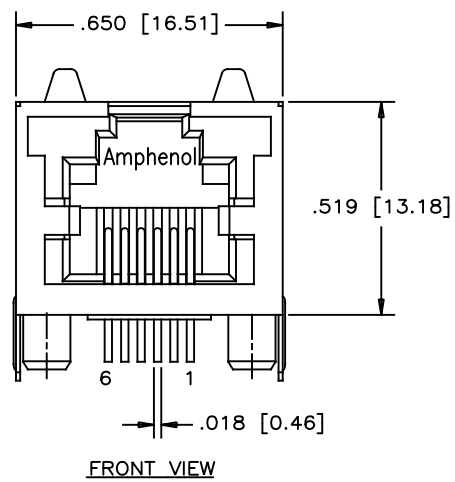

MATERIALS:

- PLASTIC HOUSING: HIGH TEMPERATURE THERMOPLASTIC
FLAMMABILITY RATING UL 94V-0 COLOR: BLACK.
- CONTACTS: PHOSPHOR BRONZE
PLATING: 50 u" [1.27 MICRONS]
MIN. GOLD ON MATING SURFACE
50 u" [1.27 MICRONS]
MIN. NICKEL UNDERPLATE
100 u" [2.54 MICRONS]
MIN. MATTE TIN ON CONTACT TAILS.
- SHIELD: STAINLESS STEEL WITH MATTE TIN PLATING ON SOLDER TAIL

PART NUMBER: RJHSE-7360

| | | |
|----------------------------|------------------------|----------------------|
| UNLESS SPECIFIED OTHERWISE | DRAWN W.QIU | DATE APR 2/18 |
| PRIMARY UNITS INCH | CHECKED L.CHAN | APP 2/18 |
| SECONDARY MILLIMETER | M.E. APP'D | |
| REFERENCE IN PARENTHESES | Q.A. APP'D | |
| GENERAL TOLERANCES | DWG APPR. | |
| 1 DECIMAL PLACE ±0.020 | ENG. REL. NO. | |
| 2 DECIMAL PLACES ±0.015 | REF. | |
| 3 DECIMAL PLACES ±0.010 | THIRD ANGLE PROJECTION | DO NOT SCALE DRAWING |
| ANGULAR DEGREES ±1.0° | | |

Amphenol Canada Corp.
Commercial Products

TITLE
RJ11 MODULAR JACK, 6 POSITIONS,
6 STAMPED CONTACTS, SHIELD, W/O LEDS
TRAY PACKAGING - RoHS COMPLIANT

DWG. NO. P-RJHSE-7360

CODE ID NO. 03554 | DWG SIZE: C | SCALE: N/A | SHEET 1 OF 2