

APPROVAL SHEET

Product Name: Quartz Thermistor Crystal

P/N.: ECS-260-9-36TC-CZY-TR

Customer's Name: _____

Specification Sheet#: _____

Date: 12/30/2020

Draw: A. Anderson

Check: D. Kelly

Customer Confirmation: _____



ECS Inc. International

TEL: 913-782-7787

FAX: 913-782-6991

http: www.ecsxtal.com



ECS Inc. International

■ REVISION HISTORY

NO.	DATE	EDITION	DRAW
1	12/30/2020	First Edition	A. Anderson
2			
3			
4			
5			
6			
7			
8			
9			
10			
11			
12			
13			
14			
15			
16			
17			
18			
19			
20			
21			
22			
23			
24			
25			
26			
27			
28			
29			
30			
31			
32			
33			
34			
35			
36			
37			



1. SCOPE

This specification relates to the Quartz Crystal to be supplied by ECS Inc. International.

2. SPECIFICATION

2-1. ELECTRICAL SPECIFICATION

Parameter	Value	Condition
Nominal Frequency	26.000000 MHz	
Mode of Vibration	AT-cut fundamental	
Operating Temperature Range	-30 ~ +85°C	
Storage Temperature Rangel	-40 ~ +105°C	
Drive level	10uW Typ., 100uW Max.	
Loading Capacitance	9 pF	
Test Set	250B PI-Network	
Initial Frequency Tolerance	±10 ppm Max.	TA= +25°C
Tolerance Over Temperature	±12 ppm Max.	TA= -30 ~ +85°C
Aging	±0.7ppm Max.	1 st year
Equivalent Series Resistance	50Ω Max.	
Spurious Mode Resistance	500Ω Min.	±1MHz
Insulation resistance	500 MΩ Min	
Coefficient range (referenced to 32°C) Note1	C1: -0.35 ~ -0.10ppm/°C C2: -12.0*10 ⁻⁴ ~ -5.0*10 ⁻⁴ ppm/°C C3: 8.7*10 ⁻⁵ ~ 11.0*10 ⁻⁵ ppm/°C	
Thermistor Resistance(25°C)	100 Kohms ±1%	TA= +25°C
Thermistor B-constant (25~50°C)	4250 K ±1%	TA= +25 ~ +50°C



Note1

The FT curve of an AT-cut crystal can be modeled as a third -order polynomial.

C0, C1, C2, and C3 are coefficients that need to be defined are calculated in the order specified.

$$f(t) = c_3(\theta)(t - t_0)^3 + c_2(\theta)(t - t_0)^2 + c_1(\theta)(t - t_0) + c_0$$

C0, C1, C2, and C3 are coefficients that need to be defined.

C1: First-order Curve Fitting Parameter

C2: Second-order Curve Fitting Parameter

C3: Third-order Curve Fitting Parameter/T0=+30.5°C

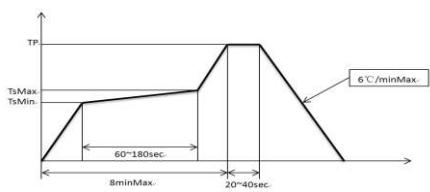

2-2. RELIABILITY TEST

NO	ITEM	CONDITIONS	BASIS OF VERDICT
1	HIGH TEMPERATURE STORAGE	Temperature: 85°C Times: 1000 hours The test was conducted 24 ±2 hours at the end of the test (no charge)	$\Delta FL \leq \pm 10$ ppm $\Delta RS \leq 5 \Omega$ or $\pm 20\%$ (Whichever is Larger)
2	CONSTANT HUMIDITY	Temperature: 85°C ±2°C; Humidity: 85%; Time: 1000 The test was conducted 24 ±2 hours at the end of the test	$\Delta FL \leq \pm 10$ ppm $\Delta RS \leq 5 \Omega$ or $\pm 20\%$ (Whichever is Larger)
3	LOW TEMPERATURE STORAGE	Temperature: -40°C Time: 1000 hours The test was conducted 24 ±2 hours at the end of the test	$\Delta FL \leq \pm 10$ ppm $\Delta RS \leq 5 \Omega$ or $\pm 20\%$ (Whichever is Larger)
4	TEMPERATURE CYCLING	-55°C ±2°C (5 min) \leftrightarrow 125°C ±2°C (5 min); For 1000 Maximum conversion time: 5 min High/Low temperature holding time: 30 min	$\Delta FL \leq \pm 10$ ppm $\Delta RS \leq 5 \Omega$ or $\pm 20\%$ (Whichever is Larger)
5	DROP	Height: 1m; 3 times	$\Delta FL \leq \pm 10$ ppm $\Delta RS \leq 5 \Omega$ or $\pm 20\%$ (Whichever is Larger)
6	MECHANICAL SHOCK	Peak: 100g's Duration: 6ms Waveform: Half-sine Velocity Change: 12.3 ft / sec Direction: +X, -X, +Y, -Y, +Z, -Z 3 times/direction Conduct electrical performance tests	$\Delta FL \leq \pm 10$ ppm $\Delta RS \leq 5 \Omega$ or $\pm 20\%$ (Whichever is Larger)
7	VIBRATION	Frequency: 10~2000Hz: Acceleration: 5g/s Direction: X, Y, Z Duration: 20min/direction. Times: 12次	$\Delta FL \leq \pm 10$ ppm $\Delta RS \leq 5 \Omega$ or $\pm 20\%$ (Whichever is Larger)
8	WELDING HEAT RESISTANT	 <p>TP: 260°C Max TsMax: 200°C TsMin: 150°C CYCLE TIME: 2次</p>	$\Delta FL \leq \pm 10$ ppm $\Delta RS \leq 5 \Omega$ or $\pm 20\%$ (Whichever is Larger)
9	SOLDER	Pretreatment before test: 155°C high-temperature store 4 hours Temperature: 260°C ±5°C, immersion	Solder Coverage \geq 95%
10	TERMINAL STRENGTH	1.8kg, of the tangential thrust (60 s) 1.8kg of the perpendicular tension (60 s)	No Rupture Observed

3. Appearance

3.1 Outline Dimensions and Recommended Land Pattern

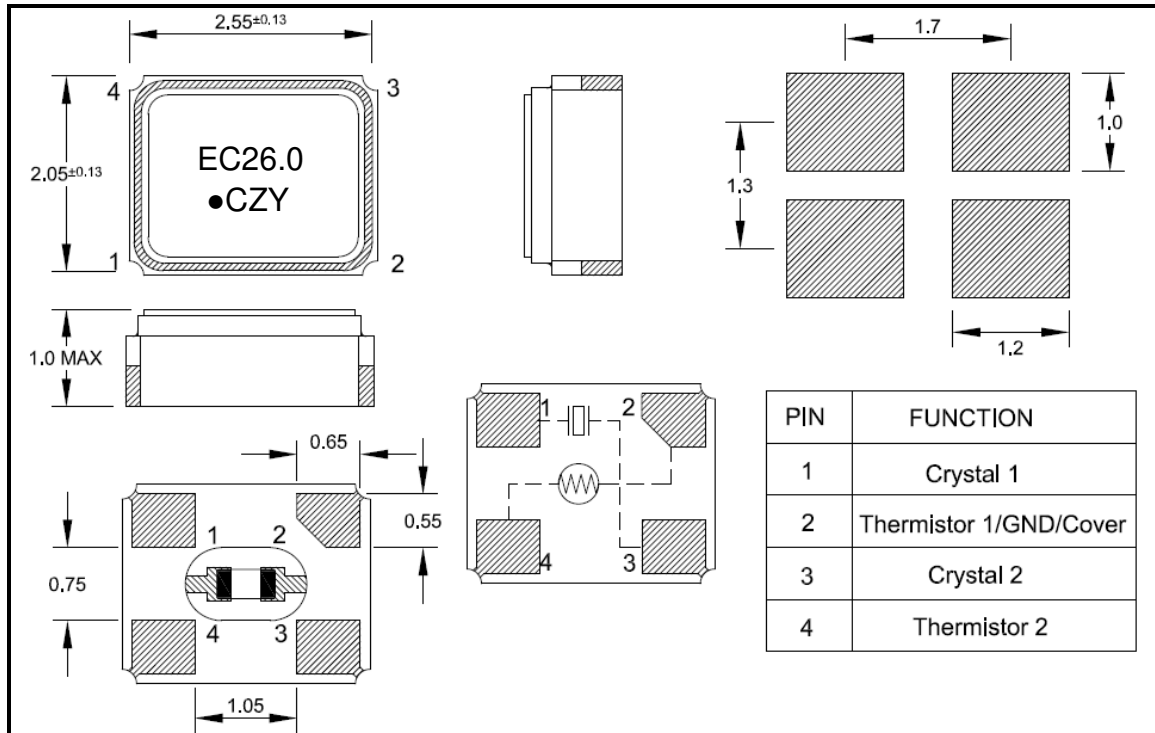

3.2 Marking Information

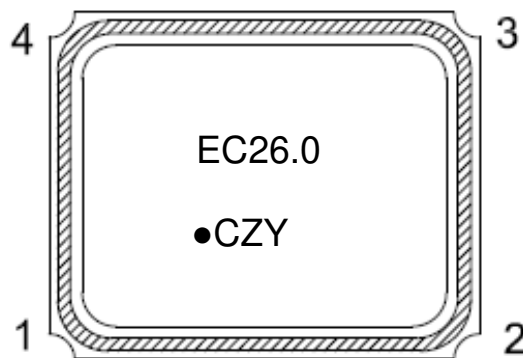

ITEM	Marking	REMARK
①	EC	ECS Inc. International
②	26.0	26.000 MHz
③	CZY	Spec ($\pm 10/12$ ppm $-30 \sim +85^{\circ}\text{C}$)
④	●	1 # PIN

4. TAPE AND REEL PACKING

4-1. TAPING SPECIFICATION

(1) Tape Dimensions

Material of Carrier Tape: Black conductive PS

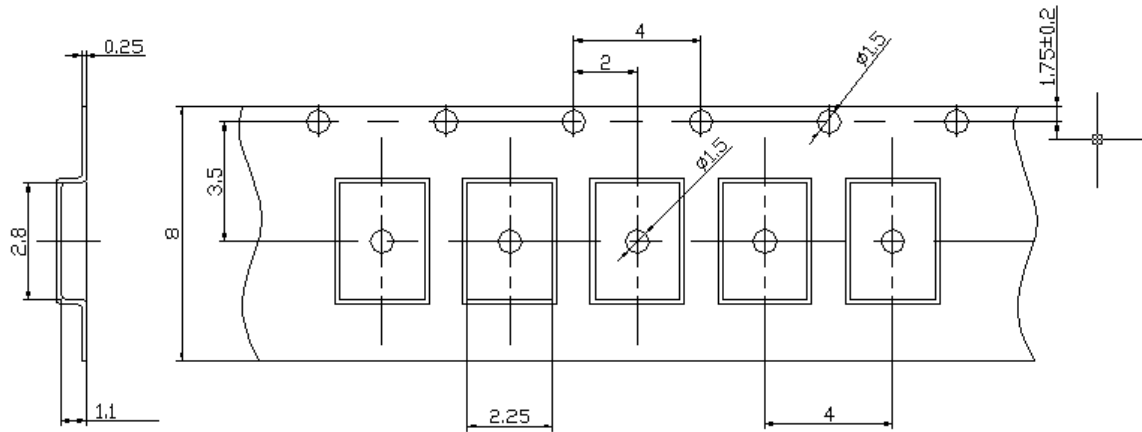

(2) Reel Dimensions

Material of the Reel: PS

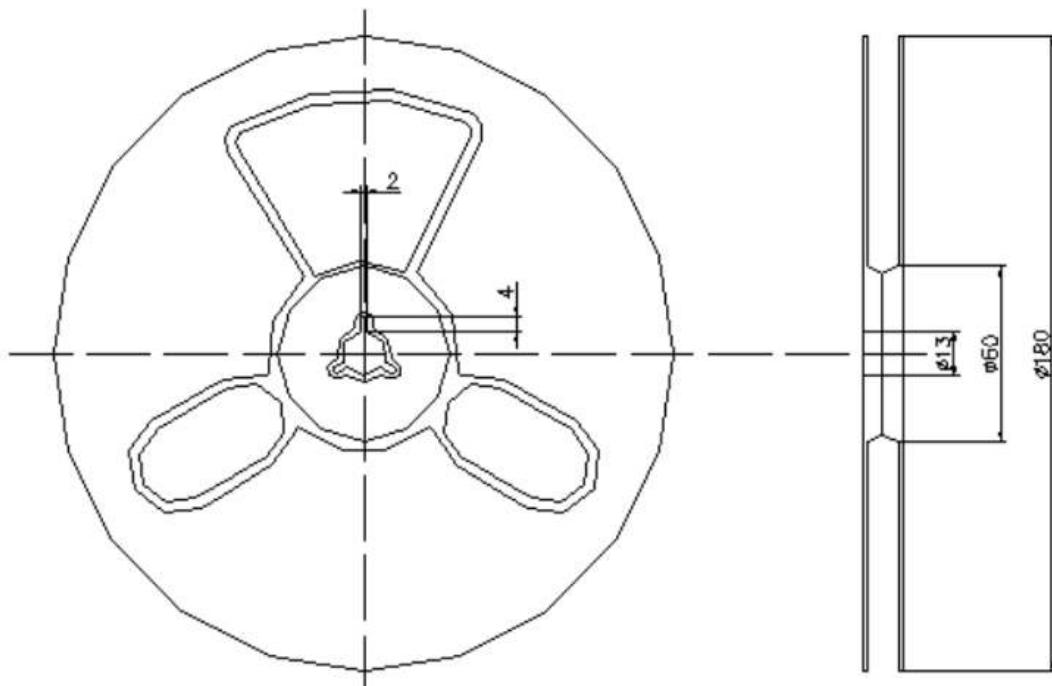

(3) Taping Method

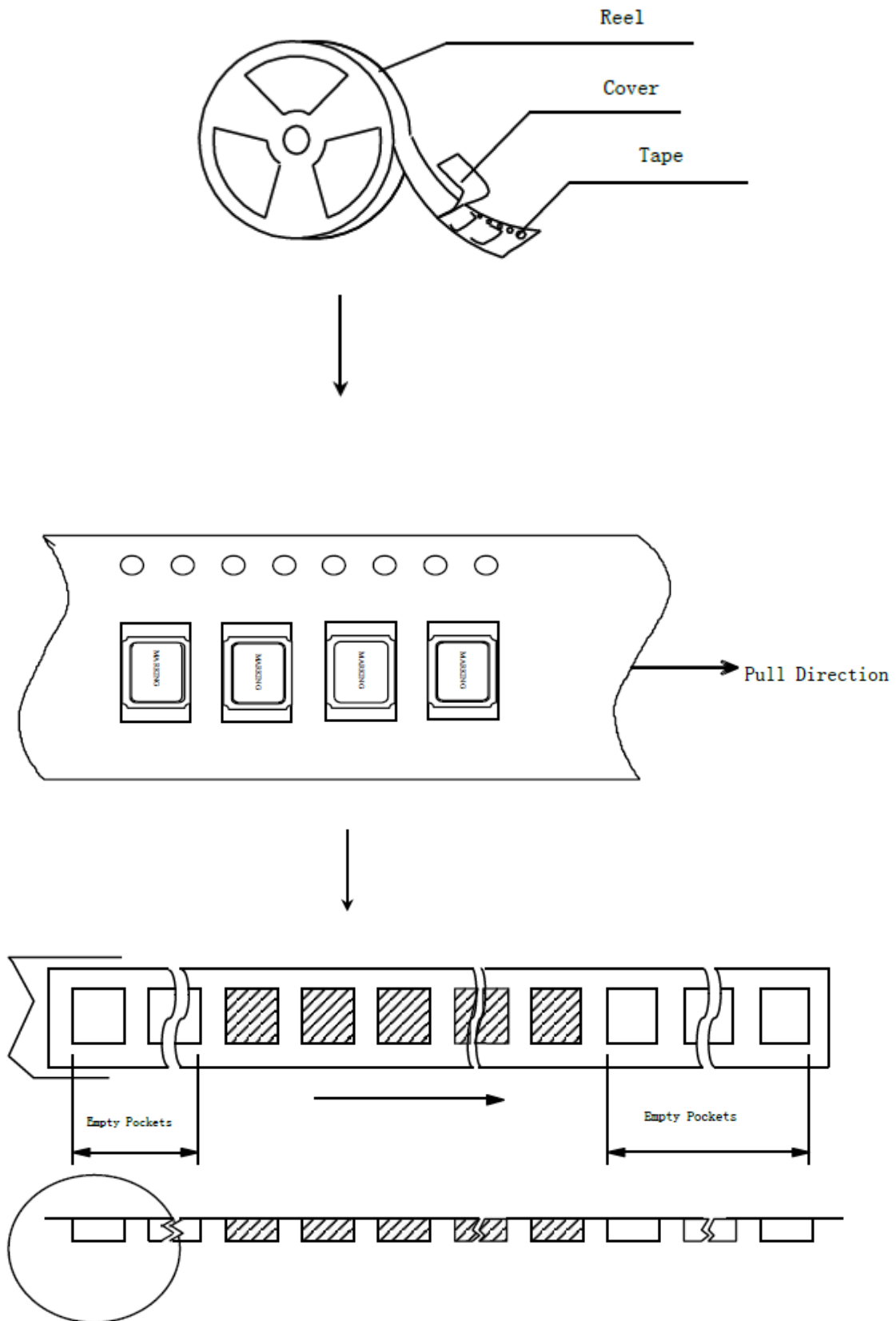



3-2. Warehouse Condition

- (1) Temperature: -10 ~ +40°C
- (2) Humidity: 45% ~ 75%