

HFM5500

RS232 Fiber Optic Host Powered Modem

FEATURES

- Plugs directly into the 25 pin connector on computers and peripheral devices
- Full duplex, asynchronous, DC to 19.2 kb/s data rate
- Extends RS232C link length up to 3 km on 50/125 μ m fiber optic cable
- Power provided by host's RS232 drivers, or power cube for better performance
- Complete electrical isolation over the link
- Can solve EMI/RFI, ground loop and lightning problems
- DCE or DTE switchable
- Small physical size L=73, W=17, H= 55(mm), 46g.

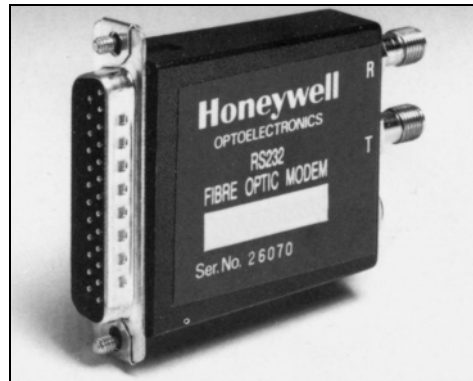

OPHO_233.TIF

DESCRIPTION

The Honeywell fiber optic RS232C link is a plug compatible replacement for most 4 and 9 wire RD232C/V24 extension cables. This link provides an effective way of extending cables beyond the 50 feet limit of standard RS232C while providing EMI/RFI protection, data security, reduced error rate, and elimination of ground loops. The modules support full duplex asynchronous data rates from DC to 19.2 Kb/s.

The HFM5500 modem can be powered in four ways:-

- 1) self powered from data line only
- 2) self powered from control lines
- 3) with external power cube
- 4) via host, pin 9, DB25 connector

Full duplex communication is provided when modules are inter-connected with a duplex fiber optic cable.

Another feature of the module is the internal DCE/DTE jumper connectors. This provides the user with one module type for both DTE and DCE equipment without additional changes. DTE mode configured as standard.

The modem is supplied in light on idle mode (optically inverting). Light off idle versions are available as an option.

HFM5500

RS232 Fiber Optic Host Powered Modem

DESCRIPTION (continued)

Configuration and diagnostics

The HFM5500 modem can be switched from the default DTE mode to DCE by rotating the 2 internal jumpers through 90° as shown in Figure 2. Note - This modem contains delicate and sensitive parts. Care must be taken to ensure no undue strain is placed on the leads of the fiber optic ports when removing the case. Remove the single screw and three 10mm nuts. The PCB will slide out of the case, take care not to overtighten when replacing the nuts.

During installation measure for an output from the transmitters, connect the fiber optic cable and check again for an output. If the transmitters and the cables are operating correctly and the link fails to function, diagnostics can be performed using Pin 8, the link monitor, as follows:

- 1) 0V on pin 8: No electrical or optical signal. Check power supply.
- 2) +V RS232 outpur (on Pin 8): Electrical and optical signals present. Check transmitters and cable link.
- 3) -V RS232 outpur (on Pin 8): No optical signal i.e. electrical only. Check transmitters and cable link.

The HFM5500 modem is designed to operate with all types of RS232 drivers and receivers.

If the modem is to be powered via a power cube, part number SPX5135 must be used. Typical current consumption is 40 mA.

There are no conditions placed on the state of the control pins in the host equipment.

HFM5500

RS232 Fiber Optic Host Powered Modem

OPTICAL SPECIFICATIONS

Item	Typical Units
Rx overload (mean)	50 μ W (-13 dBm) nominal
Tx coupled power : - Self powered Data Lines only (mean)	0.25 μ W 50/125 (-36 dBm) 0.5 μ W 62.5/125 (-33 dBm)
Cube powered (mean)	1 μ W 50/125 (-30 dBm) 2 μ W 62.5/125 (-27 dBm)

Reliability :-

MTBF	@ 25°C = 560,000 hours @ 55°C = 86,945 hours
------	---

ABSOLUTE MAXIMUM RATINGS

Operating temperature	0°C to 40°C
Storage temperature	-10°C to 60°C
Humidity	10% to 90% non-condensing

Stresses greater than those listed under "Absolute Maximum Ratings" may cause permanent damage to the device. This is a stress rating only and functional operation of the device at these or any other conditions above those indicated in the operational section of this specification is not implied. Exposure to absolute maximum rating conditions for extended periods of time may affect reliability.

STANDARDS

EN50081-1	Class B radiated emissions.
EN50082-1	Class B conducted emissions.
EN50082-1	Cat. A, 3 mV/m radiated immunity.
IEC801-2	Cat. B, 15 KV electrostatic discharge.

HFM5500

RS232 Fiber Optic Host Powered Modem

ORDER GUIDE

Description	Catalog Listing
X = A - Async, light off idle / B - Async, light on idle (Standard)	HFM5500-xyz
Y = A - SMA optical port / B - ST optical port	
Z = M - Male 25 pin 'D' / F - Female 25 pin 'D'	
The standard power supply cube has 240 VAC input and 9 V (nom) output.	SPX5135-UK
European power cube has 240 VAC input and 9 VDC output with continental 2 pin terminals.	SPX5135-EC
USA power cube has 110 VAC input and 9 VDC output with US spade terminals.	SPX5135-US

HFM5500

RS232 Fiber Optic Host Powered Modem

SCHEMATIC DIAGRAM CURRENTLY IN DTE CONFIGURATION

OSCH_047.DOC

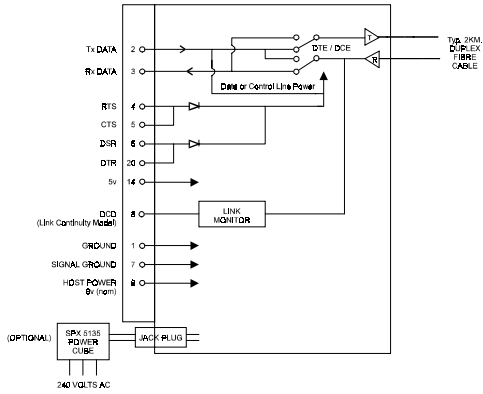

FIGURE 1 - SCHEMATIC DIAGRAM CURRENTLY IN DTE CONFIGURATION (i.e. CONNECTS TO A DTE)

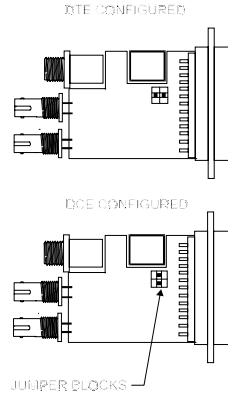

FIGURE 2 - DTE / DCE CONFIGURATION