

| PART NUMBER | REVISION | DESCRIPTION                      | FEED TYPE  |
|-------------|----------|----------------------------------|------------|
| 2150191-1   | F        | FINE CRIMP HEIGHT ADJUST         | MECHANICAL |
| 2150191-2   | F        | FINE CRIMP HEIGHT ADJUST         | PNEUMATIC  |
| 7-2150191-1 | F        | MECHANICAL AND CRIMP TOOLING KIT | MECHANICAL |
| 7-2150191-2 | F        | PNEUMATIC AND CRIMP TOOLING KIT  | PNEUMATIC  |
| 7-2150191-7 | A        | CRIMP TOOLING KIT                | -          |

ATLANTIC VERSION TERMINATOR INTERFACE ADAPTER

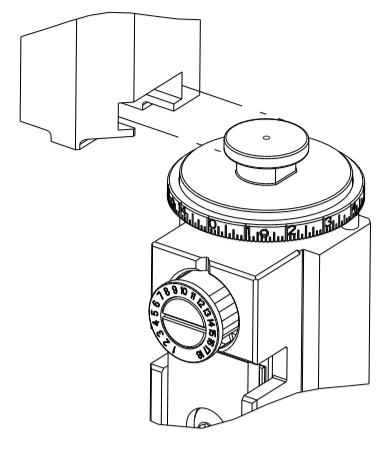

| APPLICATOR DATA                |                |      |
|--------------------------------|----------------|------|
| CRIMP                          | SIZE           | TYPE |
| WIRE                           | 2.79 mm [.110] | F    |
| INSUL                          | 3.56 mm [.140] | OV   |
| APPL INSTRUCTIONS<br>408-35043 |                |      |

| TERMINAL DATA: TE TERMINAL                    |             | TE CRIMP SPECIFICATION       |             |
|---|-------------|------------------------------|-------------|
| TERMINAL NAME: .250 SRS FAST-IN-ON RECEPTACLE |             |                              |             |
| WIRE STRIP LENGTH                             |             | INSULATION DIAMETER RANGE    |             |
| 5.80-6.60 mm [.228-.260 IN]                   |             | ∅2.10-3.10 mm [.083-.122 IN] |             |
| TERMINAL APPLICATION SPECIFICATION            | 114-2025    |                              |             |
| TERMINALS APPLIED                             |             |                              |             |
| TE TERMINAL                                   | TE TERMINAL | TE TERMINAL                  | TE TERMINAL |
| 160927-1                                      | 160927-2    | 160927-3                     | 160927-4    |

| WIRE SIZE | CRIMP HEIGHT mm [INCH]     | CRIMP HEIGHT REFERENCE SETTING |
|-----------|----------------------------|--------------------------------|
| 2.50mm2   | 1.77+/-0.05 [.070+/- .002] | 3.9                            |
| 2.00mm2   | 1.64+/-0.05 [.065+/- .002] | 5.2                            |
| 1.50mm2   | 1.51+/-0.05 [.059+/- .002] | 6.7                            |
| 1.00mm2   | 1.42+/-0.05 [.056+/- .002] | 7.5                            |

- RECOMMENDED SPARE PARTS
- REFER TO SUPPLIED INSTRUCTION SHEET FOR CLEANING, LUBRICATION AND STORAGE OF APPLICATOR.
- APPLY PART NUMBER 2-23419-6 LOCTITE TO THREADS OF ITEM 242. APPLY PART NUMBER 1-23419-5 LOCTITE TO THREADS OF ITEM 50.
- CRIMP HEIGHT REFERENCE SETTING WAS THE SETTING USED WHEN THE APPLICATOR WAS QUALIFIED AT THE FACTORY. ADJUSTMENT MAY BE NECESSARY WHEN RUNNING APPLICATOR IN THE FIELD.
- TERMINAL LUBRICANT IS RECOMMENDED.
- 6. UNLESS SPECIFIED OTHERWISE TORQUE VALUES SHALL BE USED PER DOCUMENT, 101-35000.

**\*WARNING**  
ON INSTALLATION, SET WIRE DISC TO CRIMP HEIGHT REFERENCE SETTING FOR LARGEST WIRE SIZE. CRIMP HEIGHT REFERENCE SETTINGS GREATER THAN THE VALUE SHOWN MAY CAUSE DAMAGE TO THE CRIMP TOOLING. REFER TO THE INSTRUCTION SHEET FOR PROPER SETUP AND ADJUSTMENTS.

ATLANTIC VERSION  
Shown on sheets 1 of 4 & 2 of 4  
(Pacific version shown on sheets 3 of 4 & 4 of 4)

| LOC | DIST | REVISIONS |     |               |           |     |      |
|-----|------|-----------|-----|---------------|-----------|-----|------|
| A   | 66   | P         | LTN | DESCRIPTION   | DATE      | OWN | APVD |
|     |      | C         |     | ECR-17-009263 | 26JUN2017 | TB  | TE   |
|     |      | D         |     | ECR-18-015451 | 28SEP2018 | TB  | TE   |
|     |      | E         |     | ECR-21-002654 | 02MAR2021 | JAH | RK   |
|     |      | F         |     | ECR-23-164961 | 31JAN2023 | FZ  | TE   |

|   |           |     |     |     |             |                                     |         |
|---|-----------|-----|-----|-----|-------------|-------------------------------------|---------|
| - | 1         | -   | 1   | -   | 2119641-1   | FEED CAM, AIR FEED                  | 248     |
| - | 1         | 1   | 1   | 1   | 2119082-9   | CAM, SNAIL, INSULATION ADJUSTMENT   | 244     |
| - | 1         | 1   | 1   | 1   | 2079764-1   | WASHER, WAVE SPRING, CREST-TO-CREST | 243     |
|   | -         | 1   | 1   | 1   | 2119083-1   | RETAINER, INSULATION DIAL           | 242     |
| - | -         | 1   | -   | 1   | 2119580-1   | MECHANICAL FEED ASSEMBLY            | 239     |
| - | 1         | -   | 1   | -   | 2844940-3   | AIR FEED MODULE                     | 238     |
| - | 1         | 1   | 1   | 1   | 1-18028-0   | WASHER, FLAT, REG M8                | 192     |
| - | 1         | 1   | 1   | 1   | 6-993111-6  | PIN, SLOTTED SPRING 3.0 X 14.0      | 177     |
| - | 1         | 1   | 1   | 1   | 8-22280-7   | SPRING, COMPRESSION                 | 176     |
| - | 1         | 1   | 1   | 1   | 1752353-2   | GUIDE PIN, HOLDDOWN                 | 175     |
| - | 1         | 1   | 1   | 1   | 1901680-2   | GUIDE PIN, HOLDDOWN                 | 174     |
| - | REF       | REF | REF | REF | 994970-2    | COUNTER, MAGNETIC                   | 164     |
|   | -         | 1   | 1   | 1   | 2119955-2   | ASSY, LUBRICATOR, END FEED          | 84      |
| - | 1         | 1   | 1   | 1   | 455888-4    | SPACER, CRIMPER                     | 82      |
| - | 1         | 1   | 1   | 1   | 1803607-4   | DOCUMENTATION PACKAGE               | 71      |
| - | 2         | 2   | 2   | 2   | 2-18032-2   | SCR, SET, FLT PNT, M3 X 10.0        | 70      |
| - | 1         | 1   | 1   | 1   | 2119740-1   | TAG, IDENTIFICATION                 | 67      |
| - | 2         | 2   | 2   | 2   | 2168078-1   | SCREW, DRIVE, RH, RoHS, 2 x .188    | 66      |
| - | 1         | 1   | 1   | 1   | 1901681-5   | HOLDDOWN, TERMINAL                  | 65      |
| - | 2         | 2   | 2   | 2   | 2168400-5   | SHCS, LOW HEAD, RoHS, M4 X 20       | 64      |
| - | 1         | 1   | 1   | 1   | 2168083-2   | SCR, SKT HD CAP, RoHS, M4 X 8.0     | 60      |
| - | 1         | 1   | 1   | 1   | 5-18022-5   | SCR, HEX HD CAP, M4 X 6.0           | 59      |
| - | -         | 1   | -   | 1   | 2063961-1   | FEED FINGER                         | 58      |
| - | 3         | 3   | 3   | 3   | 2168400-4   | SHCS, LOW HEAD, RoHS, M4 X 8        | 57      |
| - | 2         | 2   | 2   | 2   | 1-2168083-0 | SCR, SKT HD CAP, RoHS, M4 X 10      | 56      |
| - | 2         | 2   | 2   | 2   | 5018030-1   | NUT, HEX, REG, RoHS, M3             | 54      |
| - | 2         | 2   | 2   | 2   | 986965-8    | NUT, LOCK, HEX, TORQUE (M4)         | 53      |
| - | 1         | 1   | 1   | 1   | 1-5018030-0 | NUT, HEX, REG, RoHS, M3.5           | 52      |
| - | 1         | -   | 1   | -   | 2063961-1   | FEED FINGER                         | 51      |
|   | -         | 1   | 1   | 1   | 1-1976055-1 | STANDOFF, HOLD-DOWN                 | 50      |
| - | 1         | 2   | 1   | 2   | 18023-9     | SCR, SKT HD CAP M4 X 6.0            | 49      |
| - | -         | 1   | -   | 1   | 2119652-1   | FEED CAM, PRE FEED                  | 48      |
| - | -         | 1   | -   | 1   | 2119653-1   | FEED CAM, POST FEED                 | 47      |
| - | 1         | 1   | 1   | 1   | 2119655-5   | APPLICATOR BASIC ASSEMBLY, EF       | 46      |
| - | 1         | 1   | 1   | 1   | 1803517-1   | RAM ASSEMBLY, EF ATLANTIC           | 44      |
| - | 1         | 1   | 1   | 1   | 1803602-1   | SCR, BHSC, RoHS (M8 X 25)           | 41      |
| - | 7         | 7   | 7   | 7   | 1-18028-2   | WASHER, FLAT, REG M4                | 33      |
| - | 2         | 2   | 2   | 2   | 2168083-9   | SCR, SKT HD CAP, RoHS, M4 X 20      | 31      |
| - | 2         | 2   | 2   | 2   | 2168083-2   | SCR, SKT HD CAP, RoHS, M4 X 8.0     | 29      |
| - | 1         | 1   | 1   | 1   | 240639-1    | STRIPPER (MACHINING)                | 27      |
| - | 2         | 2   | 2   | 2   | 1-2168083-5 | SCR, SKT HD CAP, RoHS, M4 X 30      | 25      |
| - | 1         | 1   | 1   | 1   | 1752371-3   | PLATE, STRIP GUIDE                  | 24      |
| - | 1         | 1   | 1   | 1   | 240825-1    | PLATE, STRIP HOLD DOWN              | 23      |
| - | 2         | 2   | 2   | 2   | 2-22281-3   | SPRING, COMPRESSION                 | 22      |
| - | 1         | 1   | 1   | 1   | 1803292-4   | DRAG                                | 20      |
| - | 2         | 2   | 2   | 2   | 1901259-5   | GUIDE, LOWER STRIP                  | 18      |
| - | 4         | 4   | 4   | 4   | 1-2079383-1 | SCR, BHSC, RoHS (M6 X 12)           | 17      |
| - | 1         | 1   | 1   | 1   | 1752360-1   | SPACER, HOLD-DOWN                   | 13      |
|   | -         | 1   | 1   | 1   | 240644-1    | PLATE, REAR SHEAR                   | 11      |
| - | -         | -   | -   | -   | -           | -                                   | 10      |
|   | -         | 1   | 1   | 1   | 690482-3    | PLATE, FRONT SHEAR                  | 9       |
|   | 1         | 2   | 2   | 1   | 1333219-6   | ANVIL, COMBINATION                  | 8       |
|   | -         | 1   | 1   | 1   | 1-2217206-3 | BLADE, SLUG                         | 7       |
| - | -         | -   | -   | -   | -           | -                                   | 6       |
| - | 1         | 1   | 1   | 1   | 1-240641-2  | SPACER                              | 5       |
| - | 1         | 1   | 1   | 1   | 238011-2    | BLOCK, CRIMPER SPACER               | 4       |
|   | 1         | 2   | 2   | 1   | 3-2119785-3 | CRIMPER, INSULATION OVERLAP PREMIUM | 3       |
| - | 1         | 1   | 1   | 1   | 455888-7    | SPACER, CRIMPER                     | 2       |
|   | 1         | 2   | 2   | 1   | 5-730251-9  | CRIMPER, WIRE                       | 1       |
|   | -77-72-71 | -2  | -1  |     | PART NO     | DESCRIPTION                         | ITEM NO |

| DIMENSIONS: |         | TOLERANCES UNLESS OTHERWISE SPECIFIED: |          | OWN       |         | TE Connectivity                        |        |
|-------------|---------|--|----------|-----------|---------|--|--------|
| mm          | 0 PLC ± | 1 PLC ±                                | 2 PLC ±  | 11JUN2013 | HOFFNER | Harrisburg, PA 17105-3608              |        |
|             | 3 PLC ± | 4 PLC ±                                | ANGLES ± | 12JUN2013 | ELBIN   | Ocean End Feed Applicator              |        |
| MATERIAL    | FINISH  | FINISH                                 | FINISH   | 12JUN2013 | ELBIN   | Customer Accessible Production Drawing |        |
|             |         |  |          |           |         | SCALE                                  | 1:1    |
|             |         |  |          |           |         | SHEET                                  | 1 of 4 |
|             |         |  |          |           |         | REV                                    | F      |

| LOC | DIST | REV | DESCRIPTION | DATE | OWN | APVD |
|-----|------|-----|-------------|------|-----|------|
| A   | 66   |     | SEE SHEET 1 |      |     |      |

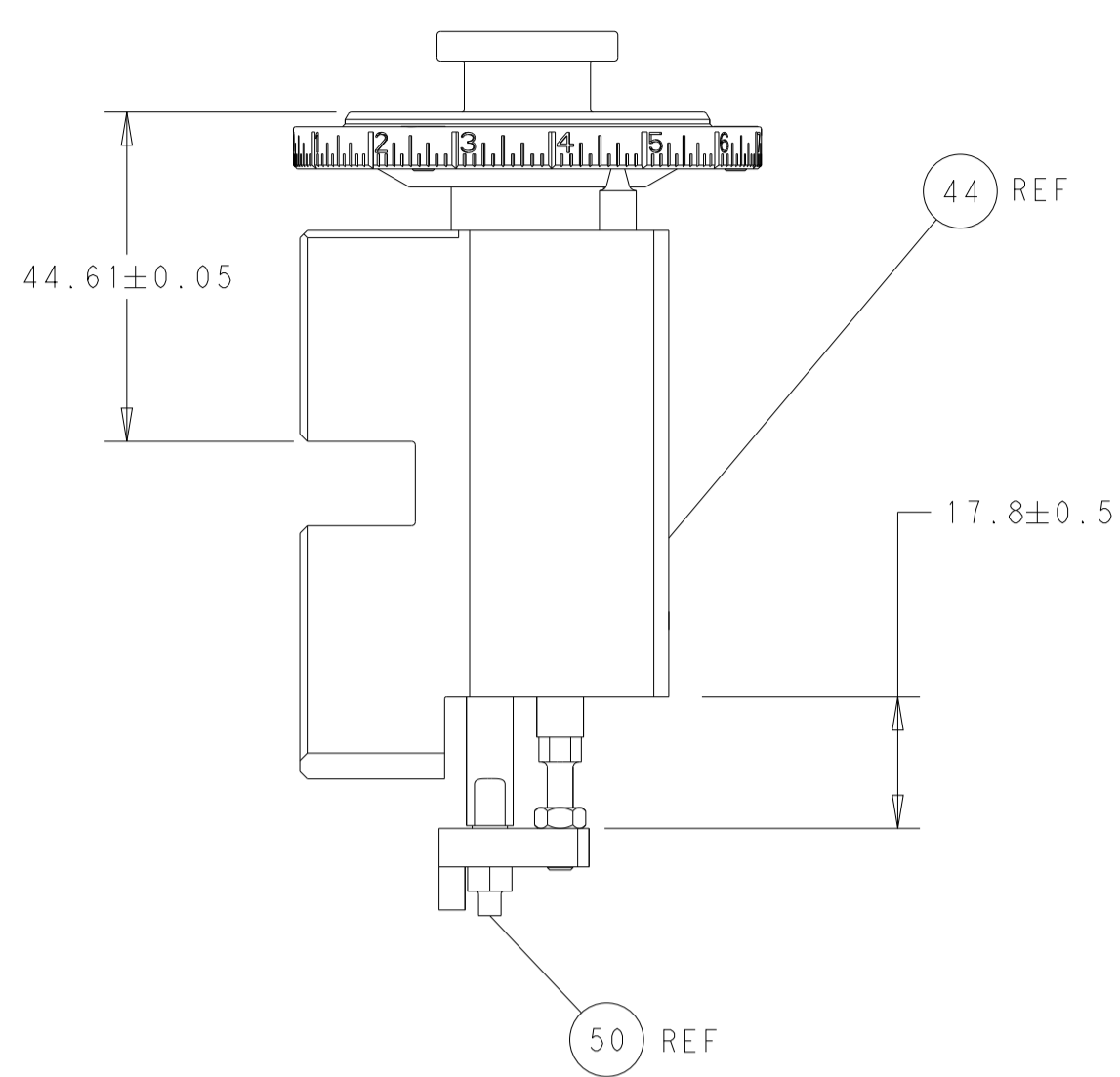

RAM AND HOLDDOWN SET-UP

FEED TYPE  
MECHANICAL

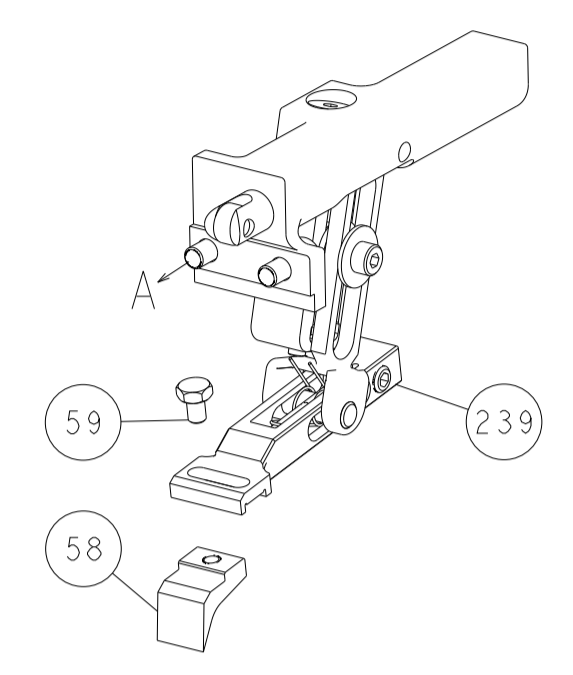

PNEUMATIC

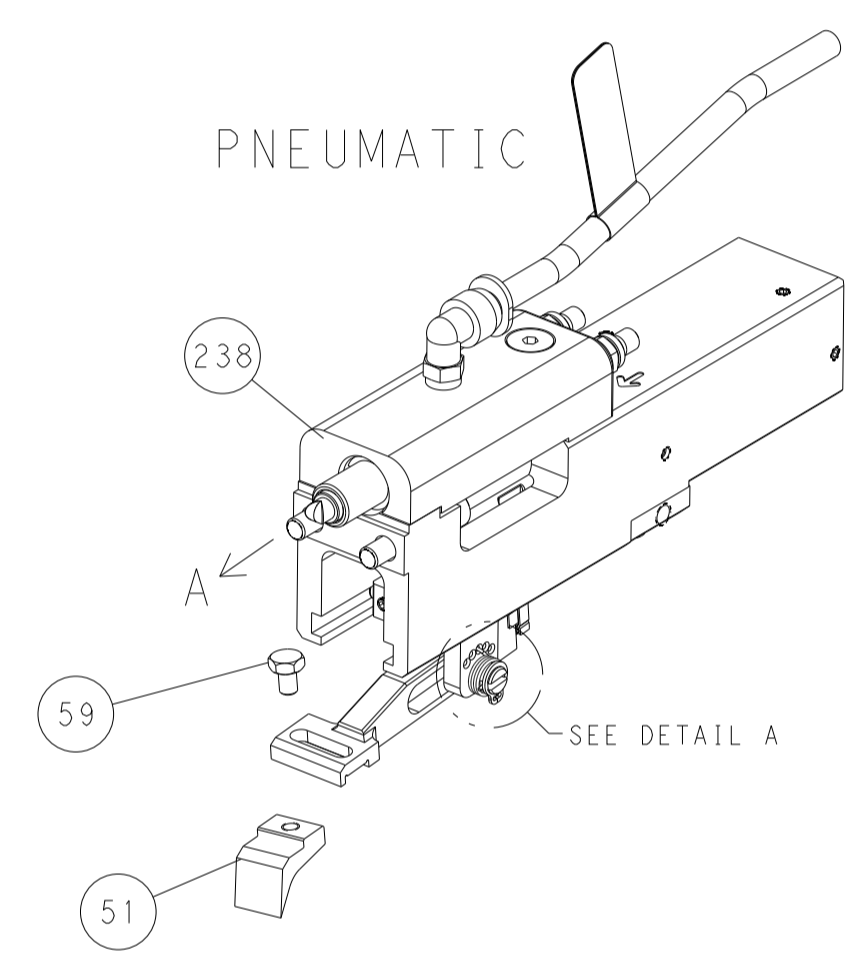

FEED SPRING  
SETTING POSITION

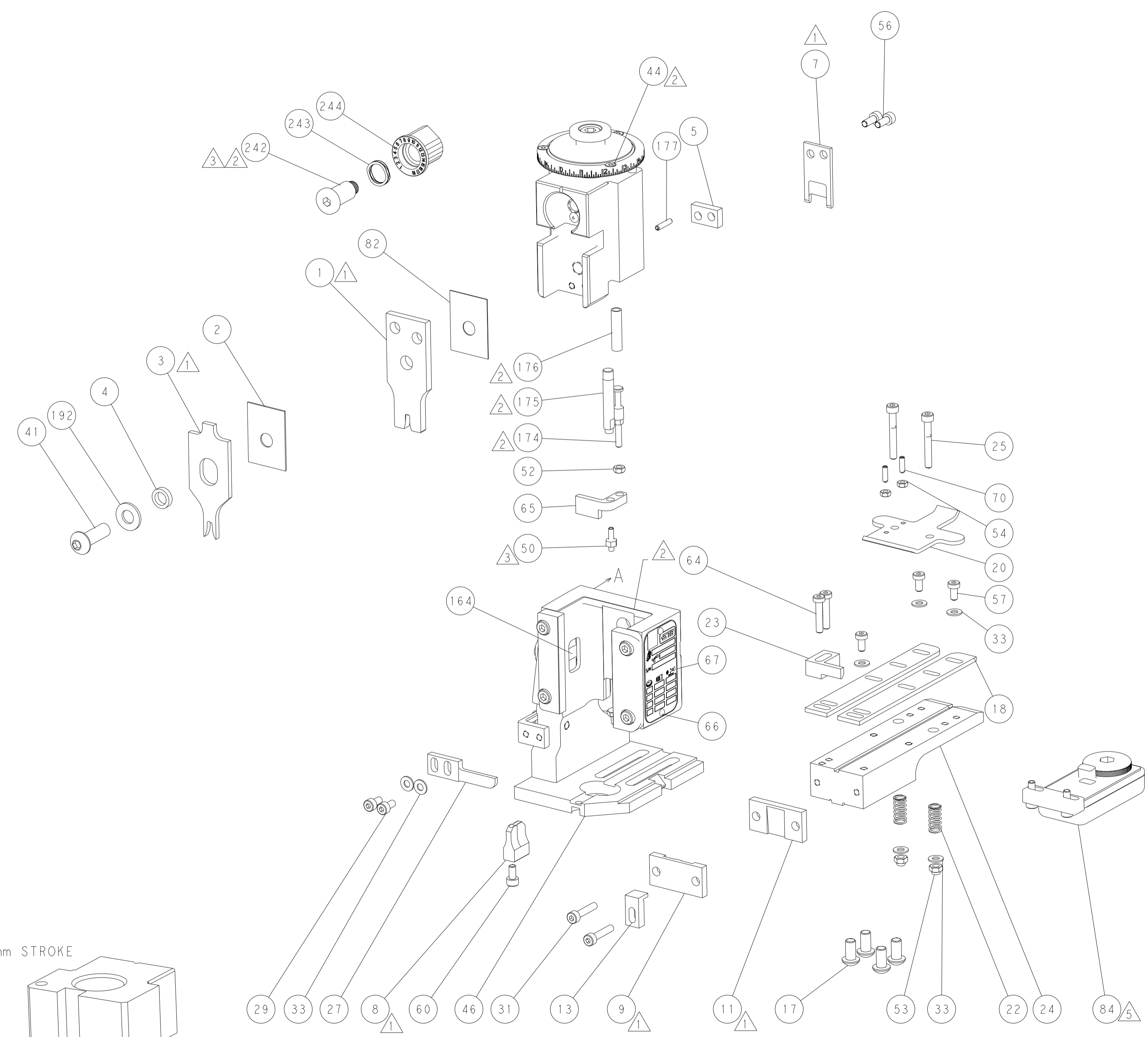
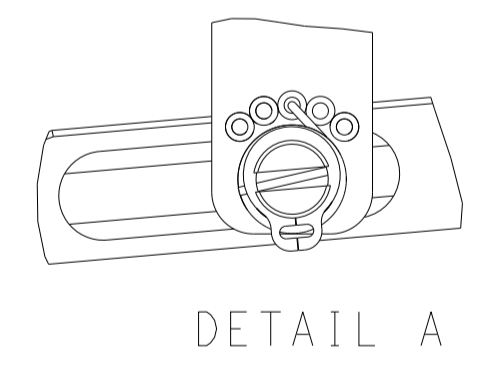

CAM POSITIONS

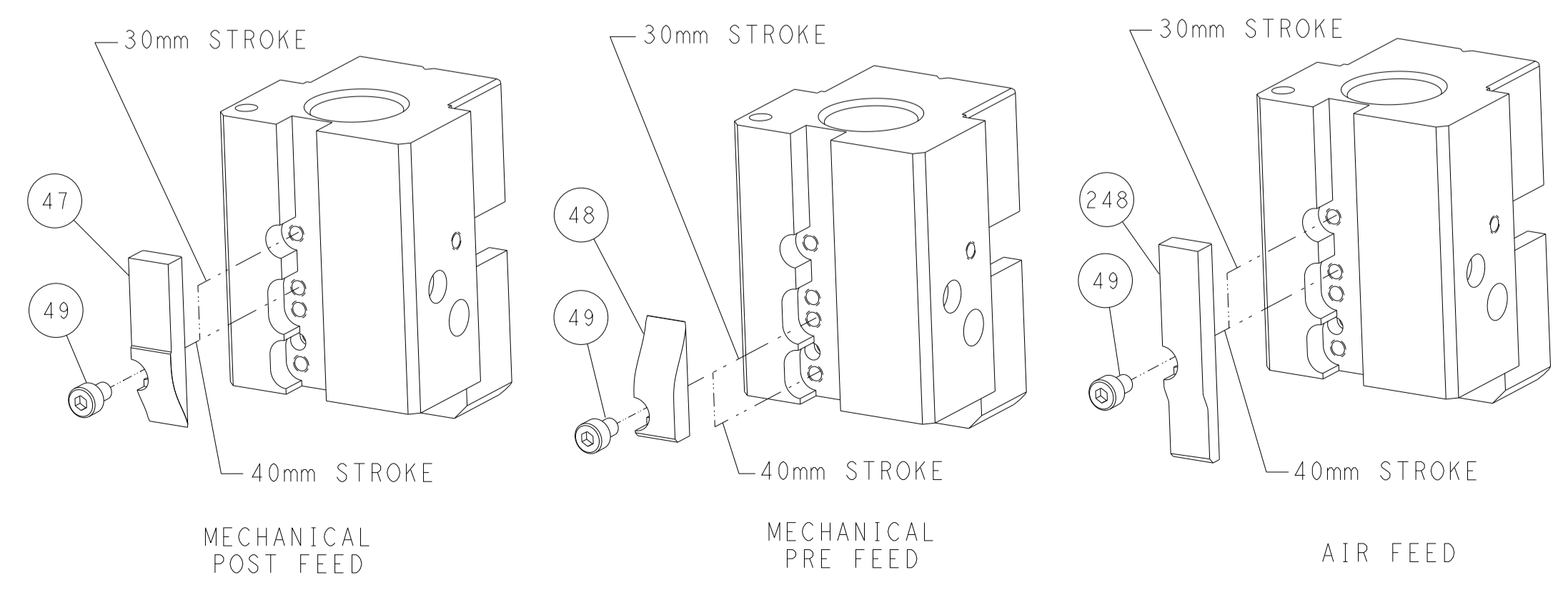

ATLANTIC VERSION  
 Shown on sheets 1 of 4 & 2 of 4  
 (Pacific version shown on sheets 3 of 4 & 4 of 4)

|   |   |   |  |
|---|---|---|--|
| <small>THIS DRAWING IS A CONTROLLED DOCUMENT FROM TYCO ELECTRONICS CORPORATION. IT IS THE PROPERTY OF TYCO ELECTRONICS CORPORATION AND IS NOT TO BE REPRODUCED OR TRANSMITTED IN ANY FORM OR BY ANY MEANS, ELECTRONIC OR MECHANICAL, INCLUDING PHOTOCOPYING, RECORDING, OR BY ANY INFORMATION STORAGE AND RETRIEVAL SYSTEM, WITHOUT THE WRITTEN PERMISSION OF TYCO ELECTRONICS CORPORATION.</small> |   | OWN: HOFFNER 11JUN2013<br>CHK: T. ELBIN 12JUN2013<br>APVD: T. ELBIN 12JUN2013 | TE Connectivity<br>Harrisburg, PA 17105-3608 |
| DIMENSIONS: mm<br>TOLERANCES UNLESS OTHERWISE SPECIFIED:<br>0 PLC ±<br>1 PLC ±<br>2 PLC ±<br>3 PLC ±<br>4 PLC ±<br>ANGLES ° ±<br>FINISH   | NAME: Ocean End Feed Applicator<br>SIZE: A1<br>CAGE CODE: 00779<br>DRAWING NO: 2150191<br>SCALE: 1:1<br>SHEET: 2 of 4<br>REV: F | WEIGHT: -<br>RESTRICTED TO: -   | CUSTOMER ACCESSIBLE PRODUCTION DRAWING       |

| PART NUMBER | REVISION | DESCRIPTION              | FEED TYPE  |
|-------------|----------|--------------------------|------------|
| 2-2150191-1 | F        | FINE CRIMP HEIGHT ADJUST | MECHANICAL |
| 2-2150191-2 | F        | FINE CRIMP HEIGHT ADJUST | PNEUMATIC  |
| 7-2150191-7 | A        | CRIMP TOOLING KIT        | -          |

PACIFIC VERSION TERMINATOR  
 INTERFACE ADAPTER

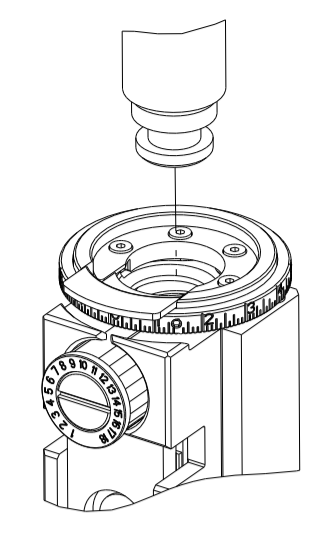

APPLICATOR DATA

| CRIMP | SIZE             | TYPE |
|-------|------------------|------|
| WIRE  | 2.79 mm [ .110 ] | F    |
| INSUL | 3.56 mm [ .140 ] | OV   |

APPL INSTRUCTIONS  
 408-35043

TERMINAL DATA: TE TERMINAL TE CRIMP SPECIFICATION

TERMINAL NAME: .250 SRS FAST-IN-ON RECEPTACLE

| WIRE STRIP LENGTH             | INSULATION DIAMETER RANGE      |
|-------------------------------|--------------------------------|
| 5.80-6.60 mm [ .228-.260 IN ] | ∅2.10-3.10 mm [ .083-.122 IN ] |

TERMINAL APPLICATION SPECIFICATION 114-2025

TERMINALS APPLIED

| TE TERMINAL | TE TERMINAL | TE TERMINAL | TE TERMINAL |
|-------------|-------------|-------------|-------------|
| 160927-1    | 160927-2    | 160927-3    | 160927-4    |

| WIRE SIZE | CRIMP HEIGHT mm [INCH]       | CRIMP HEIGHT REFERENCE SETTING |
|-----------|------------------------------|--------------------------------|
| 2.50mm2   | 1.77+/-0.05 [ .070+/- .002 ] | 3.9                            |
| 2.00mm2   | 1.64+/-0.05 [ .065+/- .002 ] | 5.2                            |
| 1.50mm2   | 1.51+/-0.05 [ .059+/- .002 ] | 6.7                            |
| 1.00mm2   | 1.42+/-0.05 [ .056+/- .002 ] | 7.5                            |



- RECOMMENDED SPARE PARTS
- REFER TO SUPPLIED INSTRUCTION SHEET FOR CLEANING, LUBRICATION AND STORAGE OF APPLICATOR.
- APPLY PART NUMBER 2-23419-6 LOCTITE TO THREADS OF ITEM 242. APPLY PART NUMBER 1-23419-5 LOCTITE TO THREADS OF ITEM 50.
- CRIMP HEIGHT REFERENCE SETTING WAS THE SETTING USED WHEN THE APPLICATOR WAS QUALIFIED AT THE FACTORY. ADJUSTMENT MAY BE NECESSARY WHEN RUNNING APPLICATOR IN THE FIELD.
- TERMINAL LUBRICANT IS RECOMMENDED.
- UNLESS SPECIFIED OTHERWISE TORQUE VALUES SHALL BE USED PER DOCUMENT, 101-35000.

**\*WARNING**  
 ON INSTALLATION, SET WIRE DISC TO CRIMP HEIGHT REFERENCE SETTING FOR LARGEST WIRE SIZE. CRIMP HEIGHT REFERENCE SETTINGS GREATER THAN THE VALUE SHOWN MAY CAUSE DAMAGE TO THE CRIMP TOOLING. REFER TO THE INSTRUCTION SHEET FOR PROPER SETUP AND ADJUSTMENTS.

PACIFIC VERSION  
 Shown on sheets 3 of 4 & 4 of 4  
 (Atlantic version shown on sheets 1 of 4 & 2 of 4)

| LOC | DIST | REVISIONS |     |             |      |     |      |
|-----|------|-----------|-----|-------------|------|-----|------|
| A   | 66   | P         | LTN | DESCRIPTION | DATE | OWN | APVD |
| -   | -    | -         | -   | SEE SHEET 1 | -    | -   | -    |

|   |     |     |             |                                     |         |
|---|-----|-----|-------------|-------------------------------------|---------|
| - | 1   | 1   | 2119082-9   | CAM, SNAIL, INSULATION ADJUSTMENT   | 244     |
| - | 1   | 1   | 2079764-1   | WASHER, WAVE SPRING, CREST-TO-CREST | 243     |
| - | 1   | 1   | 2119083-1   | RETAINER, INSULATION DIAL           | 242     |
| - | -   | 1   | 2119580-1   | MECHANICAL FEED ASSEMBLY            | 239     |
| - | 1   | -   | 2844940-3   | AIR FEED MODULE                     | 238     |
| - | 1   | 1   | 1-18028-0   | WASHER, FLAT, REG M8                | 192     |
| - | 4   | 4   | 2079383-9   | SCR, BHSC, RoHS (M6 X 20)           | 186     |
| - | 1   | 1   | 6-993111-6  | PIN, SLOTTED SPRING 3.0 X 14.0      | 177     |
| - | 1   | 1   | 8-22280-7   | SPRING, COMPRESSION                 | 176     |
| - | 1   | 1   | 1752353-2   | GUIDE PIN,HOLDDOWN                  | 175     |
| - | 1   | 1   | 1901680-2   | GUIDE PIN,HOLDDOWN                  | 174     |
| - | REF | REF | 994970-2    | COUNTER, MAGNETIC                   | 164     |
| - | 1   | -   | 2119641-2   | FEED CAM, AIR FEED                  | 152     |
| - | 1   | 1   | 2168083-8   | SCR, SKT HD CAP, RoHS, M4 X 16      | 144     |
| - | -   | 1   | 2119653-2   | FEED CAM, POST FEED                 | 142     |
| - | 1   | 1   | 2119655-6   | APPLICATOR BASIC ASSEMBLY, EF       | 141     |
| - | 1   | 1   | 1803518-1   | RAM ASSEMBLY, EF PACIFIC            | 140     |
| - | 1   | 1   | 2119955-2   | ASSY, LUBRICATOR, END FEED          | 84      |
| - | 1   | 1   | 455888-4    | SPACER, CRIMPER                     | 82      |
| - | 1   | 1   | 1803607-4   | DOCUMENTATION PACKAGE               | 71      |
| - | 2   | 2   | 2-18032-2   | SCR, SET, FLT PNT, M3 X 10.0        | 70      |
| - | 1   | 1   | 2119740-1   | TAG, IDENTIFICATION                 | 67      |
| - | 2   | 2   | 2168078-1   | SCREW, DRIVE, RH, RoHS, 2 x .188    | 66      |
| - | 1   | 1   | 1901681-5   | HOLDDOWN, TERMINAL                  | 65      |
| - | 2   | 2   | 2168400-5   | SHCS, LOW HEAD, RoHS, M4 X 20       | 64      |
| - | 1   | 1   | 5-18022-5   | SCR, HEX HD CAP, M4 X 6.0           | 59      |
| - | -   | 1   | 2063961-1   | FEED FINGER                         | 58      |
| - | 3   | 3   | 2168400-4   | SHCS, LOW HEAD, RoHS, M4 X 8        | 57      |
| - | 2   | 2   | 1-2168083-0 | SCR, SKT HD CAP, RoHS, M4 X 10      | 56      |
| - | 2   | 2   | 5018030-1   | NUT, HEX, REG, RoHS, M3             | 54      |
| - | 2   | 2   | 986965-8    | NUT, LOCK, HEX, TORQUE (M4)         | 53      |
| - | 1   | 1   | 1-5018030-0 | NUT, HEX, REG, RoHS, M3.5           | 52      |
| - | 1   | -   | 2063961-1   | FEED FINGER                         | 51      |
| - | 1   | 1   | 1-1976055-1 | STANDOFF, HOLD-DOWN                 | 50      |
| - | 1   | 2   | 18023-9     | SCR, SKT HD CAP M4 X 6.0            | 49      |
| - | -   | 1   | 2119652-1   | FEED CAM, PRE FEED                  | 48      |
| - | 1   | 1   | 1803602-1   | SCR, BHSC, RoHS (M8 X 25)           | 41      |
| - | 7   | 7   | 1-18028-2   | WASHER, FLAT, REG M4                | 33      |
| - | 2   | 2   | 2168083-9   | SCR, SKT HD CAP, RoHS, M4 X 20      | 31      |
| - | 2   | 2   | 2168083-2   | SCR, SKT HD CAP, RoHS, M4 X 8.0     | 29      |
| - | 1   | 1   | 240639-1    | STRIPPER (MACHINING)                | 27      |
| - | 2   | 2   | 1-2168083-5 | SCR, SKT HD CAP, RoHS, M4 X 30      | 25      |
| - | 1   | 1   | 1752371-3   | PLATE, STRIP GUIDE                  | 24      |
| - | 1   | 1   | 240825-1    | PLATE, STRIP HOLD DOWN              | 23      |
| - | 2   | 2   | 2-22281-3   | SPRING, COMPRESSION                 | 22      |
| - | 1   | 1   | 1803292-4   | DRAG                                | 20      |
| - | 2   | 2   | 1901259-5   | GUIDE, LOWER STRIP                  | 18      |
| - | 1   | 1   | 1752360-1   | SPACER,HOLD-DOWN                    | 13      |
| - | 1   | 1   | 240644-1    | PLATE, REAR SHEAR                   | 11      |
| - | -   | -   | -           | -                                   | 10      |
| - | 1   | 1   | 690482-3    | PLATE, FRONT SHEAR                  | 9       |
| - | 1   | 1   | 1333219-6   | ANVIL, COMBINATION                  | 8       |
| - | 1   | 1   | 1-2217206-3 | BLADE, SLUG                         | 7       |
| - | -   | -   | -           | -                                   | 6       |
| - | 1   | 1   | 1-240641-2  | SPACER                              | 5       |
| - | 1   | 1   | 238011-2    | BLOCK, CRIMPER SPACER               | 4       |
| - | 1   | 1   | 3-2119785-3 | CRIMPER, INSULATION OVERLAP PREMIUM | 3       |
| - | 1   | 1   | 455888-7    | SPACER, CRIMPER                     | 2       |
| - | 1   | 1   | 5-730251-9  | CRIMPER, WIRE                       | 1       |
| - | 77  | 22  | 21          | PART NO                             | ITEM NO |

| DIMENSIONS: |         | TOLERANCES UNLESS OTHERWISE SPECIFIED: |          | DWN       |        | TE Connectivity                        |           |
|-------------|---------|--|----------|-----------|--------|--|-----------|
| mm          | 0 PLC ± | 1 PLC ±                                | 2 PLC ±  | 11JUN2013 | OFFNER | Harrisburg, PA 17105-3608              |           |
|             | 3 PLC ± | 4 PLC ±                                | ANGLES ± | 12JUN2013 | ELBIN  | Ocean End Feed                         |           |
|             | FINISH  |  |          | 12JUN2013 | ELBIN  | Applicator                             |           |
| MATERIAL    |         |  |          |           |        | SIZE                                   | CAGE CODE |
|             |         |  |          |           |        | A1                                     | 00779     |
|             |         |  |          |           |        | DRAWING NO                             | ©=2150191 |
|             |         |  |          |           |        | RESTRICTED TO                          |           |
|             |         |  |          |           |        | Customer Accessible Production Drawing | SCALE 1:1 |
|             |         |  |          |           |        | SHEET 3 OF 4                           | REV F     |

| LOC |    | DIST |     | REVISIONS   |      |     |      |
|-----|----|------|-----|-------------|------|-----|------|
| A   | 66 | P    | LTM | DESCRIPTION | DATE | OWN | APVD |
|     |    | -    |     | SEE SHEET 1 |      |     |      |

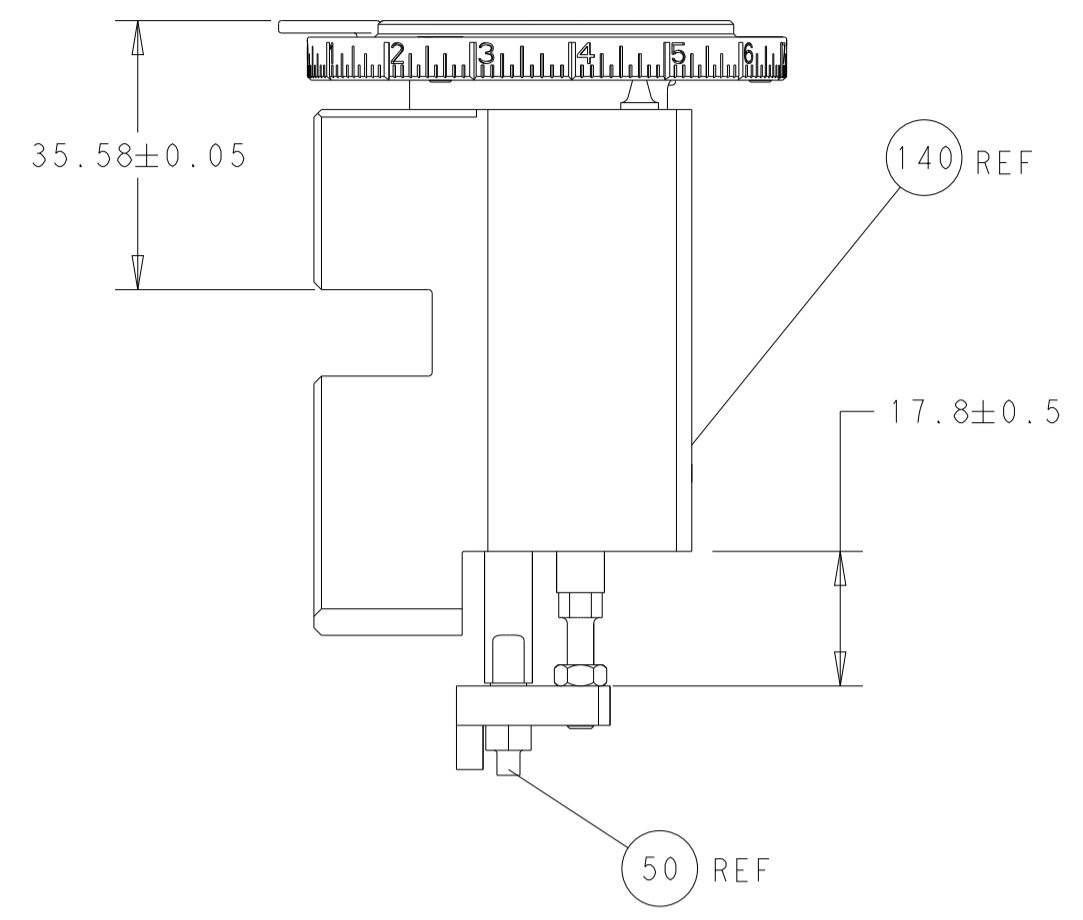

RAM AND HOLDDOWN SET-UP

FEED TYPE  
MECHANICAL

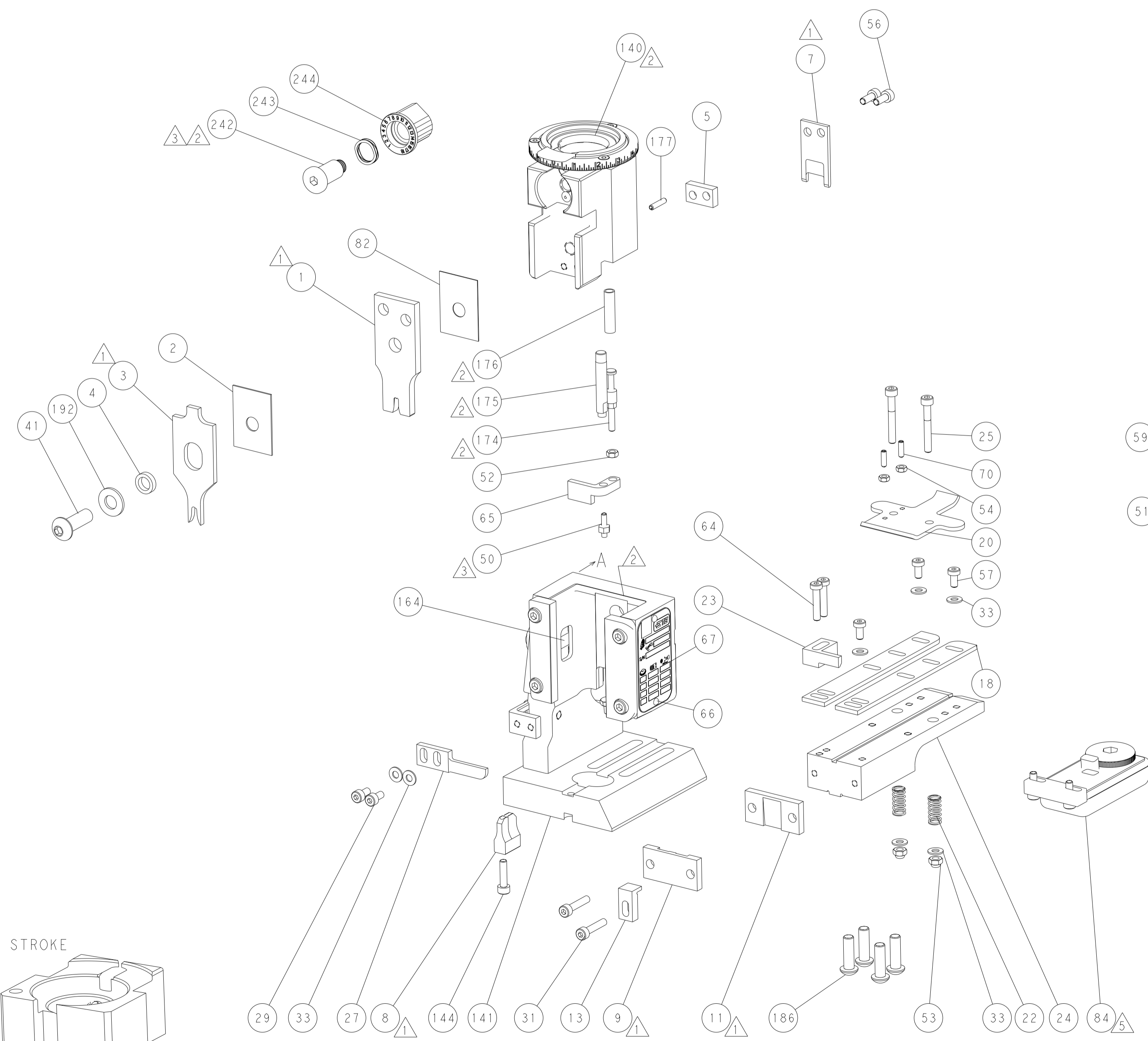
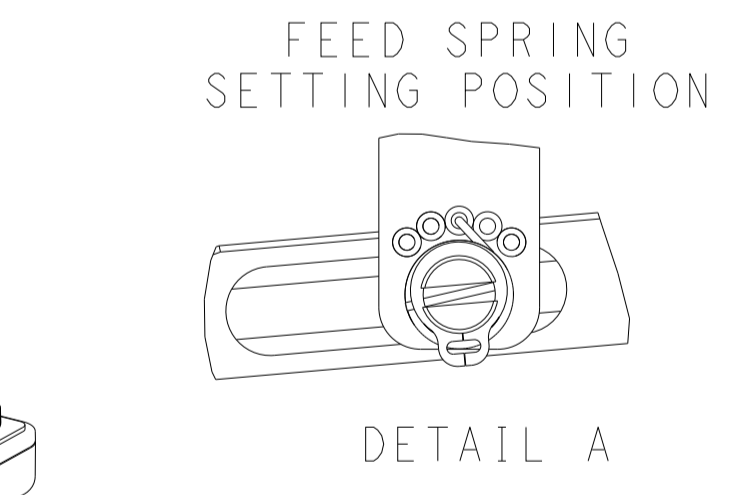
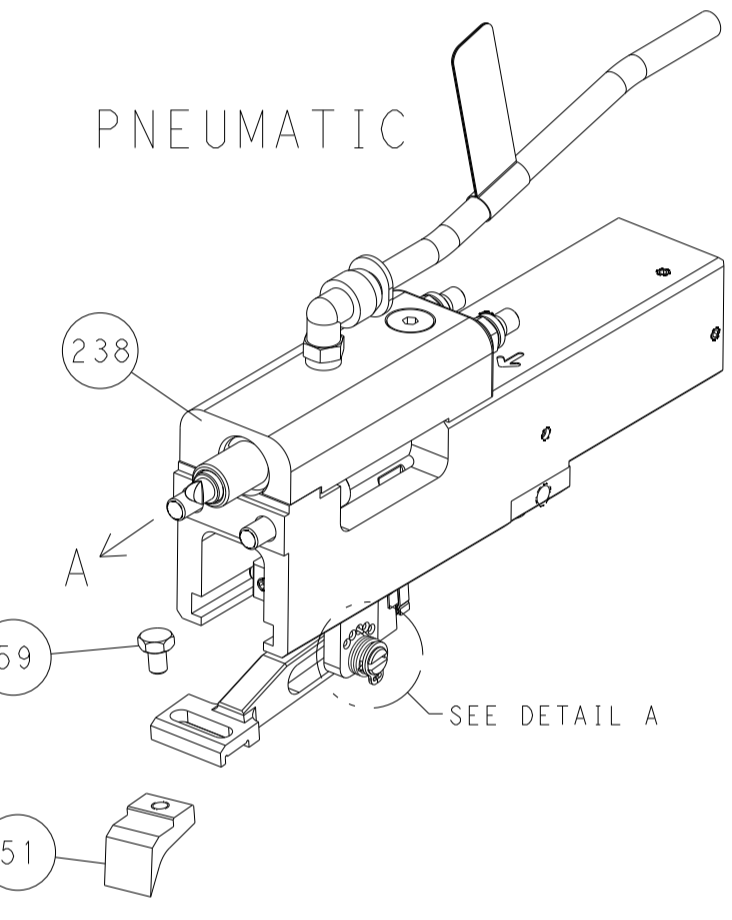
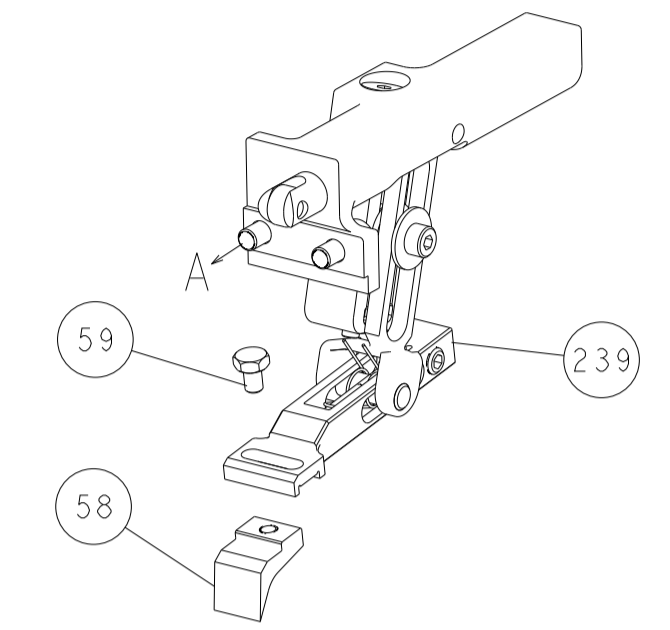

CAM POSITIONS

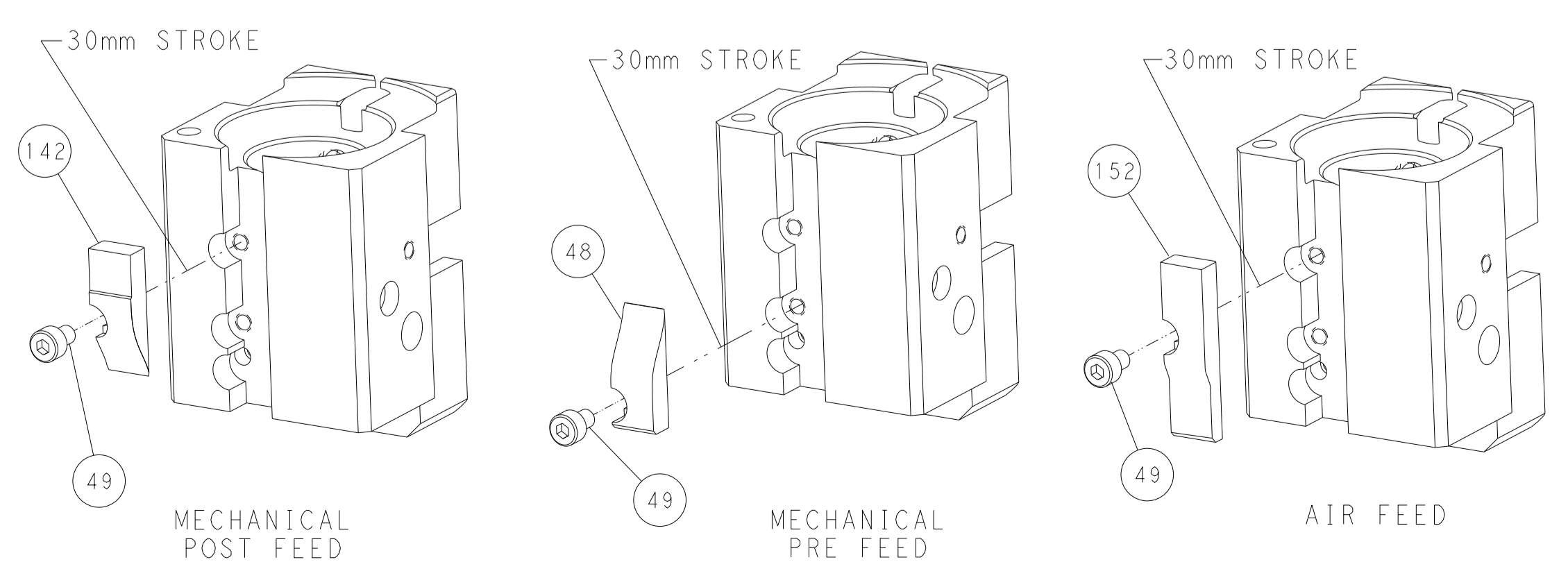

PACIFIC VERSION  
 Shown on sheets 3 of 4 & 4 of 4  
 (Atlantic version shown on sheets 1 of 4 & 2 of 4)

|   |  |  |  |
|---|--|--|--|
| <small>THIS DRAWING IS UNPUBLISHED. RELEASED FOR PUBLICATION BY TYCO ELECTRONICS CORPORATION. ALL RIGHTS RESERVED.</small>            |  | DWN: HOFFNER 11JUN2013<br>CHK: T. ELBIN 12JUN2013<br>APVD: T. ELBIN 12JUN2013  | TE Connectivity<br>Harrisburg, PA 17105-3608                                   |
| DIMENSIONS: mm<br>TOLERANCES UNLESS OTHERWISE SPECIFIED:<br>0 PLC ±<br>1 PLC ±<br>2 PLC ±<br>3 PLC ±<br>4 PLC ±<br>ANGLES ±<br>FINISH |  | NAME: Ocean End Feed Applier<br>APPLICATION SPEC: -<br>WEIGHT: -<br>SCALE: 1:1 | SIZE: A1<br>CAGE CODE: 00779<br>DRAWING NO: C=2150191<br>SHEET 4 OF 4<br>REV F |