

**Phase Control SCR**  
**900 Amperes Average**  
**1800 Volts**

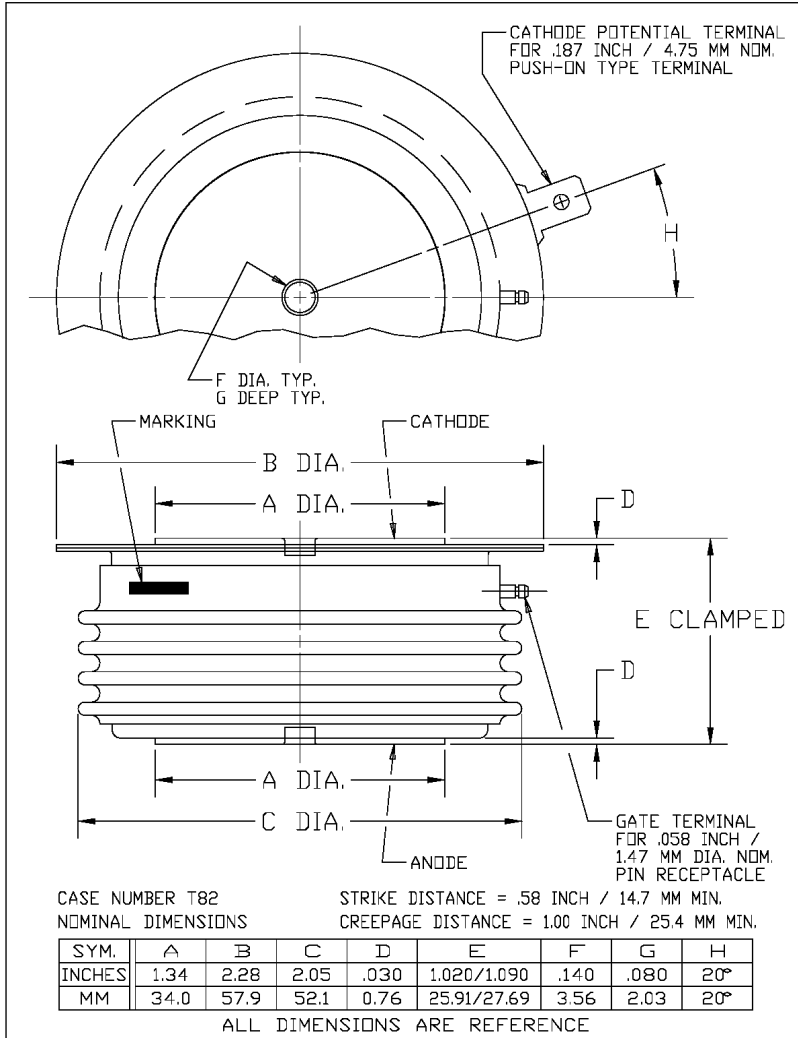

**T820 900A** (Outline Drawing)



**T820 900A Phase Control SCR**  
900 Amperes Average, 1800 Volts

**Description:**

Powerex Silicon Controlled Rectifiers (SCR) are designed for phase control applications. These are all-diffused, Press-Pak, hermetic Pow-R-Disc devices employing the field proven amplifying gate.

**Features:**

- Low On-State Voltage
- High di/dt Capability
- High dv/dt Capability
- Hermetic Packaging
- Excellent Surge and I<sup>2</sup>t Ratings

**Applications:**

- Power Supplies
- Motor Control

**Ordering Information:**

Select the complete 12 digit module part number from the table below.  
Example: T820169004DH is a 1600V 900A Phase Control SCR.

Type	Voltage V <sub>RRM</sub> (Volts)	Current I <sub>T(av)</sub> (A)	Turn-off Time t <sub>q</sub> (µsec)	Gate Current I <sub>GT</sub> (mA)	Lead Code
T820	02 through 18  200V through 1800V	90  900A	0  200 µsec (Typical)	4  150 mA	DH  12"



**T820  
900A**

Powerex, Inc., 173 Pavilion Lane, Youngwood, Pennsylvania 15697 (724) 925-7272  
www.pwrx.com

**Phase Control SCR  
900 Amperes Average  
1800 Volts**

### Absolute Maximum Ratings

Characteristics	Symbol		Units
Non-Repetitive Transient Peak Reverse Blocking Voltage	$V_{RSM}$	$V_{RRM} + 100V$	Volts
RMS On-State Current, $T_C = 70^\circ C$	$I_{T(RMS)}$	1410	Amperes
Average Current 180° Sine Wave, $T_C = 70^\circ C$	$I_{T(AV)}$	900	Amperes
RMS On-State Current, $T_C = 55^\circ C$	$I_{T(RMS)}$	1725	Amperes
Average Current 180° Sine Wave, $T_C = 55^\circ C$	$I_{T(AV)}$	1100	Amperes
Peak One Cycle Surge On-State Current (Non-Repetitive) 60 Hz	$I_{TSM}$	15,000	Amperes
Peak One Cycle Surge On-State Current (Non-Repetitive) 50 Hz	$I_{TSM}$	13,700	Amperes
Critical Rate-of-rise of On-State Current (Non-Repetitive)	$di/dt$	400	A/ $\mu$ sec
Critical Rate-of-rise of On-State Current (Repetitive)	$di/dt$	150	A/ $\mu$ sec
$I^2t$ (for Fusing) for One Cycle, 60 Hz	$I^2t$	935,000	$A^2$ sec
Peak Gate Power Dissipation	$P_{GM}$	16	Watts
Average Gate Power Dissipation	$P_{G(av)}$	3	Watts
Operating Temperature	$T_J$	-40 to +125	$^\circ C$
Storage Temperature	$T_{stg}$	-40 to +150	$^\circ C$
Approximate Weight		8	oz.
		227	g
Mounting Force		3000 to 3500	lb.
		1360 to 1590	kg.

Information presented is based upon manufacturers testing and projected capabilities.  
This information is subject to change without notice.  
The manufacturer makes no claim as to the suitability of use, reliability, capability,  
or future availability of this product.

**Electrical Characteristics,  $T_J=25^\circ\text{C}$  unless otherwise specified**

Characteristics	Symbol	Test Conditions	Min.	Typ.	Max.	Units
Repetitive Peak Reverse Leakage Current	$I_{RRM}$	$T_J=125^\circ\text{C}$ , $V_R = V_{RRM}$			60	mA
Repetitive Peak Forward Leakage Current	$I_{DRM}$	$T_J=125^\circ\text{C}$ , $V_D = V_{DRM}$			60	mA
Peak On-State Voltage	$V_{TM}$	$I_{FM}=1500\text{A peak}$ , Duty Cycle < 0.1 %			1.35	V
Threshold Voltage, Low-level	$V_{(TO)1}$	$T_J = 125^\circ\text{C}$ , $I = 15\%I_{T(AV)}$ to $\pi I_{T(AV)}$			0.78526	V
Slope Resistance, Low-level	$r_{T1}$				0.3505	$\text{m}\Omega$
Threshold Voltage, High-level	$V_{(TO)2}$	$T_J = 125^\circ\text{C}$ , $I = \pi I_{T(AV)}$ to $I_{TSM}$			1.0789	V
Slope Resistance, High-level	$r_{T2}$				0.2311	$\text{m}\Omega$
$V_{TM}$ Coefficients, Low-level		$T_J = 125^\circ\text{C}$ , $I = 15\%I_{T(AV)}$ to $\pi I_{T(AV)}$ $V_{TM} = A + B \ln(I) + C(I) + D \text{ Sqrt}(I)$		A =	0.68865	
				B =	-0.04011	
				C =	-1.578 E-05	
				D =	0.025339	
$V_{TM}$ Coefficients, High-level		$T_J = 125^\circ\text{C}$ , $I = \pi I_{T(AV)}$ to $I_{TSM}$ $V_{TM} = A + B \ln(I) + C(I) + D \text{ Sqrt}(I)$		A =	2.6289	
				B =	-0.37766	
				C =	8.873 E-05	
				D =	0.034055	
Typical Turn-On Time	$t_{on}$	$I_T = 1000\text{A}$ , $V_D = 600\text{V}$		5		$\mu\text{s}$
Typical Turn-Off Time	$t_q$	$T_J = 125^\circ\text{C}$ , $I_T = 250\text{A}$ , $di_R/dt = 50\text{A}/\mu\text{s}$ Reapplied $dv/dt = 20\text{V}/\mu\text{s}$ Linear to 80% $V_{DRM}$		200		$\mu\text{s}$
Minimum Critical $dv/dt$ – Exponential to $V_{DRM}$	$dv/dt$	$T_J = 125^\circ\text{C}$	300			$\text{V}/\mu\text{s}$
Gate Trigger Current	$I_{GT}$	$T_J = 25^\circ\text{C}$ , $V_D = 12\text{V}$			150	mA
Gate Trigger Voltage	$V_{GT}$	$T_J = 25^\circ\text{C}$ , $V_D = 12\text{V}$			3.0	V
Non-Triggering Gate Voltage	$V_{GDM}$	$T_J = 125^\circ\text{C}$ , $V_D = V_{DRM}$			0.15	V
Peak Forward Gate Current	$I_{GTM}$				4	A
Peak Reverse Gate Voltage	$V_{GRM}$				5	V

**Thermal Characteristics**

Maximum Thermal Resistance, Double Sided Cooling		Max.	Units
Junction-to-Case	$R_{\Theta(J-C)}$	0.037	$^\circ\text{C}/\text{W}$
Case-to-Sink	$R_{\Theta(C-S)}$	0.020	$^\circ\text{C}/\text{W}$

**Maximum On-State Forward Voltage Drop**  
( $T_j = 125^\circ\text{C}$ )

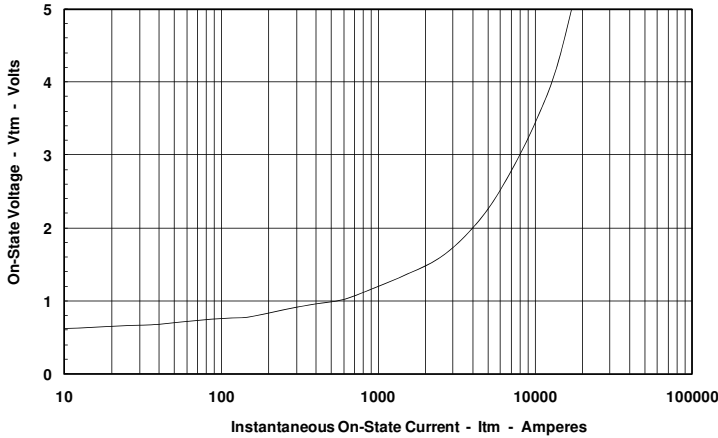

**Maximum Transient Thermal Impedance**  
(Junction to Case)

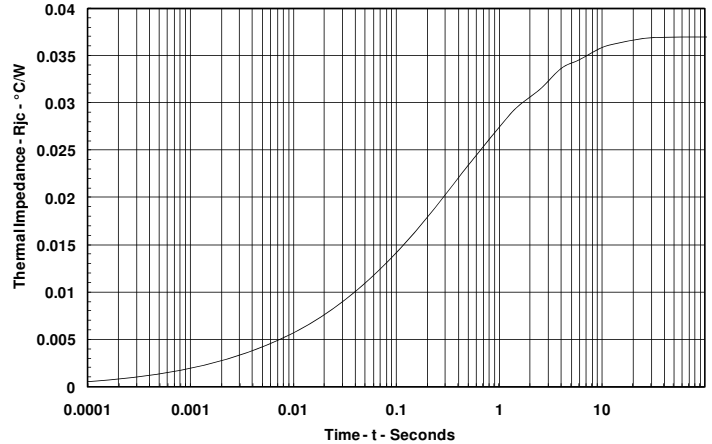

**Maximum On-State Power Dissipation**  
(Sinusoidal Waveform)

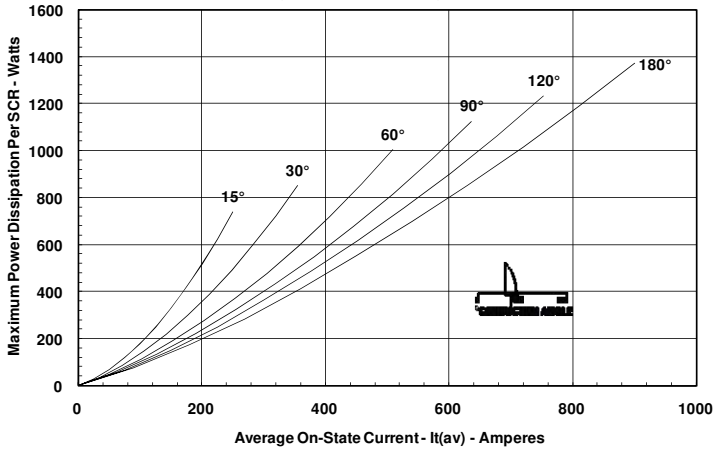

**Maximum Allowable Case Temperature**  
(Sinusoidal Waveform)

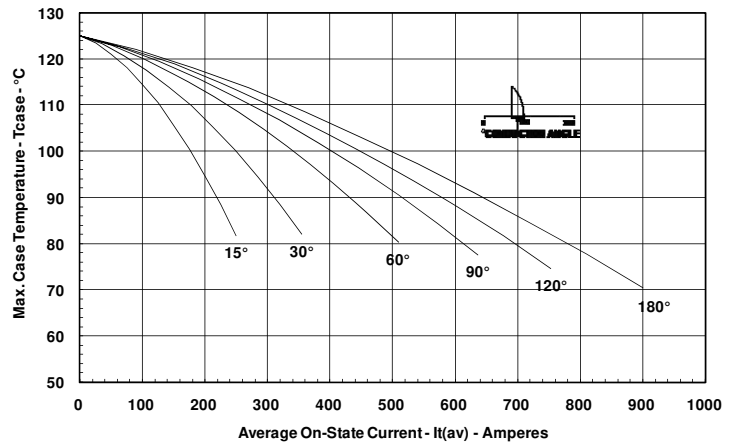

**Maximum On-State Power Dissipation**  
(Rectangular Waveform)

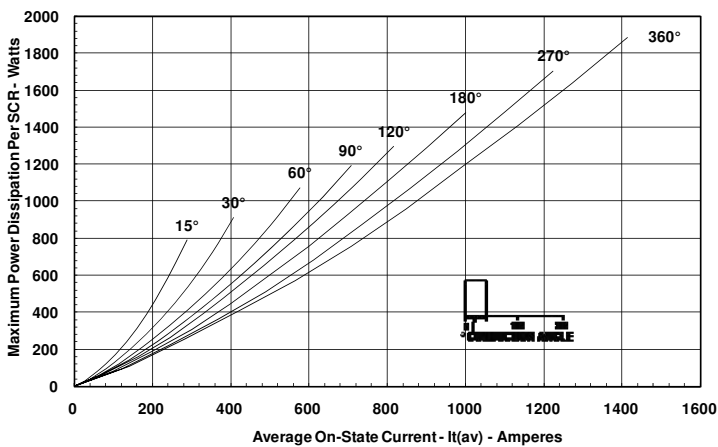

**Maximum Allowable Case Temperature**  
(Rectangular Waveform)

