



Platform Flash XL High-Density Configuration and Storage Device

DS617 (v4.0) August 5, 2015

Product Specification

Features

- In-System Programmable Flash Memory Optimized for Virtex®-5 or Virtex-6 FPGA Configuration
- High-Performance FPGA Bitstream Transfer up to 800 Mb/s (50 MHz × 16-bits), Ideal for PCI Express® Endpoint Applications
- MultiBoot Bitstream, Design Revision Storage
- FPGA Configuration Synchronization (READY_WAIT) Handshake Signal
- ISE® Software Support for In-System Programming via Xilinx® JTAG Cables
- Standard NOR-Flash Interface for Access to Code or Data Storage
- Operation over Full Industrial Temperature Range (–40°C to +85°C)
- Common Flash Interface (CFI)
- Low-Power Advanced CMOS NOR-Flash Process
- Endurance of 10,000 Program/Erase Cycles Per Block
- Power Supplies
 - ◆ Industry-Standard Core Power Supply Voltage (V_{DD}) = 1.8V
 - ◆ 3.3V or 2.5V I/O (V_{DDQ}) Power Supply Voltage
- Memory Organization
 - ◆ 128-Mb Main Array Capacity
 - ◆ 16-bit Data Bus
 - ◆ Multiple 8-Mb Bank Architecture for Dual Erase/Program and Read Operation
 - ◆ 127 Regular 1-Mb Main Blocks
 - ◆ 4 Small 256-Kb Parameter Blocks
- Synchronous/Asynchronous Read Modes
 - ◆ Power-On in Synchronous Burst Read Mode
 - ◆ Asynchronous Random Access Mode
 - ◆ Accelerated Asynchronous Page Read Mode
- Protection
 - ◆ Default Block Protection at Power-Up
 - ◆ Hardware Write Protection (when $V_{PP} = V_{SS}$)
- Security
 - ◆ Unique Device Number (64-bits)
 - ◆ One-Time-Programmable (OTP) Registers
- Small-Footprint (10 mm × 13 mm) FT64 Packaging

Description

A reliable compact high-performance configuration bitstream storage and delivery solution is essential for the high-density FPGAs. Platform Flash XL is the industry's highest performing configuration and storage device and is specially optimized for high-performance FPGA configuration. Platform Flash XL integrates 128 Mb of in-system programmable flash storage and performance features for configuration within a small-footprint FT64 package (Figure 5). Power-on burst read mode and dedicated I/O power supply enable Platform Flash XL to mate seamlessly with the native SelectMAP configuration interface. A wide, 16-bit data bus delivers the FPGA configuration bitstream at speeds up to 800 Mb/s without wait states. See [UG438, Platform Flash XL Configuration and Storage Device User Guide](#), for system-level usage and performance considerations.

Platform Flash XL is supported for use with Virtex-5 or Virtex-6 FPGAs only. Use with older Virtex families, Spartan® families, or AES encrypted bitstreams is not supported.

Platform Flash XL is a non-volatile flash storage solution, optimized for FPGA configuration. The device provides a READY_WAIT signal that synchronizes the start of the FPGA configuration process, improving both system reliability and simplifying board design. Platform Flash XL can download an XC5VLX330 bitstream (79,704,832 bits) in less than 100 ms, making the configuration performance of Platform Flash XL ideal for PCI Express endpoints and other high-performance applications.

Platform Flash XL is a single-chip configuration solution with additional system-level capabilities. A standard NOR flash interface (Figure 2) and support for common flash interface (CFI) queries provide industry-standard access to the device memory space. The Platform Flash XL's 128 Mb capacity can typically hold one or more FPGA bitstreams. Any memory space not used for bitstream storage can be used to hold general purpose data or embedded processor code.

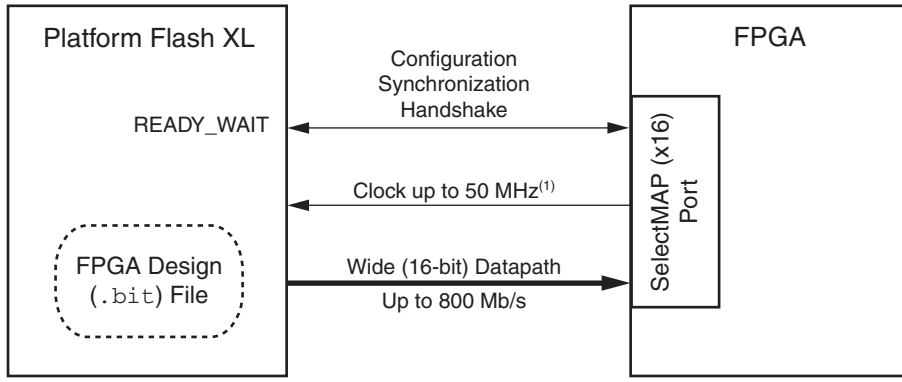

DS617_01_102709

Notes:

1. System considerations can lower the configuration clock frequency below the maximum clock frequency for the device. To determine the maximum configuration clock frequency, check the minimum clock period (T_{KHKH}) for the chosen I/O voltage range (V_{DDQ}), the clock High-to-output valid time (T_{KHQV}), and the FPGA SelectMAP setup time.

Figure 1: Platform Flash XL Delivers Reliable, High-Performance FPGA Configuration

Platform Flash XL support is integrated with the Xilinx design and debug tool suite. The iMPACT application, included with the ISE software, supports indirect, in-system programming of Platform Flash XL via the IEEE Standard 1149.1 (JTAG) port on the FPGA for prototype programming (Figure 3).

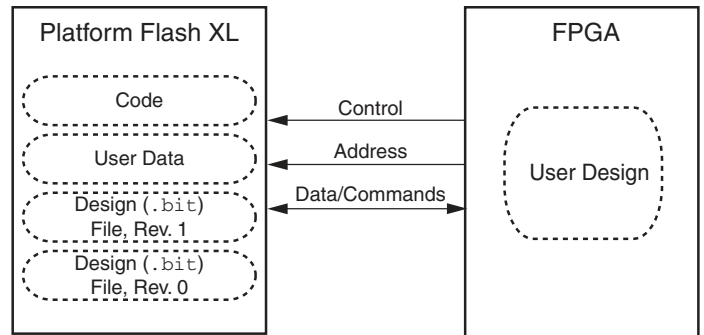

DS617_02_081209

Figure 2: Standard NOR Flash Interface for User Access to Memory

Single Cable Connector for Direct FPGA Configuration/Debug and Indirect Platform Flash XL Programming

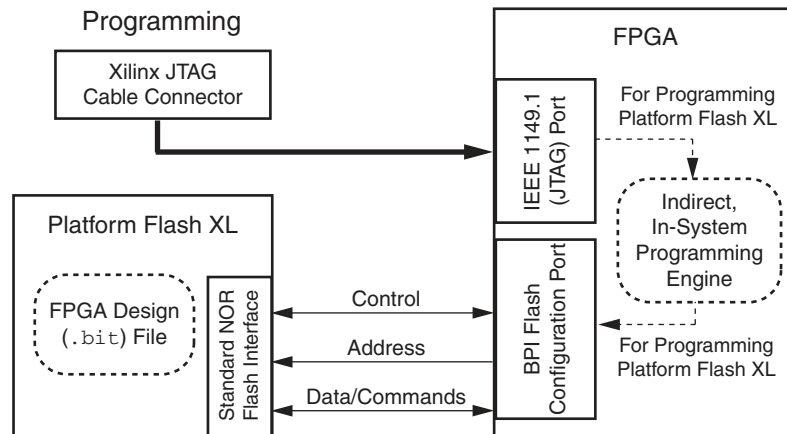

DS617_03_081209

Figure 3: Indirect Programming Solution for Platform Flash XL

Flash Memory Architecture Overview

Platform Flash XL is a 128-Mb (8 Mb × 16) non-volatile flash memory. The device is in-system programmable with a 1.8V core (V_{DD}) power supply. A separate I/O (V_{DDQ}) power supply enables I/O operation at 3.3V or 2.5V. An optional 9V V_{PP} power supply can accelerate factory programming.

A common flash interface (CFI) provides access to device memory (Figure 3, page 3). Moreover, Platform Flash XL supports multiple read modes. A 23-bit address bus provides random read access to each 16-bit word. Four words occupy each page for accelerated page mode reads. The device powers-up in a synchronous burst read mode capable of sequential read rates up to 54 MHz.

Platform Flash XL has a multiple-bank architecture. An array of 131 individually erasable blocks are divided into 16, 8-Mb banks. Fifteen main banks contain uniform blocks of 64 Kwords, and one parameter bank contains seven main blocks of 64 Kwords, plus four parameter blocks of 16 Kwords.

Note: The device is electronically erasable at the block level and programmable on a word-by-word basis.

The multiple-bank architecture allows dual operations — read operations can occur on one bank while a program or erase operation occurs in a different bank. However, only one bank at a time is allowed to be in program or erase mode. Burst reads are allowed to cross bank boundaries.

Table 1 summarizes the bank architecture, and the memory map is shown in Figure 4, page 5. The parameter blocks are located at the top of the memory address space in Platform Flash XL.

Table 1: Bank Architecture

Number	Bank Size	Parameter Blocks	Main Blocks
Parameter Bank	8 Mbits	4 blocks of 16 Kwords	7 blocks of 64 Kwords
Bank 1	8 Mbits	—	8 blocks of 64 Kwords
Bank 2	8 Mbits	—	8 blocks of 64 Kwords
Bank 3	8 Mbits	—	8 blocks of 64 Kwords
⋮	⋮	⋮	⋮
Bank 14	8 Mbits	—	8 blocks of 64 Kwords
Bank 15	8 Mbits	—	8 blocks of 64 Kwords

Each block can be erased separately. Erase operations can be suspended in order to perform a program or read operation in any other block and then resumed. Program operations can

be suspended to read data at any memory location except for the one being programmed, and then resumed.

Program and erase commands are written to the command interface of the memory. An internal program/erase controller takes care of the timing necessary for program and erase operations. The end of a program or erase operation can be detected and any error conditions identified in the status register. The command set required to control the memory is consistent with JEDEC standards.

The device supports synchronous burst read and asynchronous read from all blocks of the memory array. At power-up, the device is configured for synchronous read. In synchronous burst read mode, data is output on each clock cycle at frequencies of up to 54 MHz. The synchronous burst read operation can be suspended and resumed.

When the bus is inactive during asynchronous read operations, the device automatically switches to an automatic standby mode. In this condition the power consumption is reduced to the standby value, and the outputs are still driven.

Platform Flash XL features an instant, individual block-locking scheme, allowing any block to be locked or unlocked with no latency, and enabling instant code and data protection. All blocks have three levels of protection. Blocks can be locked and locked-down individually preventing any accidental programming or erasure. There is an additional hardware protection against program and erase: when $V_{PP} = V_{PPLK}$ all blocks are protected against program or erase. All blocks are locked at power-up.

The device features a separate region of 17 programmable registers whose values can be protected against further programming changes. Sixteen of these registers are each 128-bits in size, with the 17th register subdivided into two 64-bit registers. One of the 64-bit registers contains a factory preprogrammed, unique device number, permanently protected against modification. The second 64-bit register is user-programmable.

All bits within these registers (except for the permanently-protected unique number register) are one-time-programmable (OTP) — each bit can be programmed only once from a one-value to a zero-value.

Two protection lock registers can be programmed to lock any of the 17 protectable registers against further changes. One protection lock register contains bits that determine the protection state of the two special 64-bit registers. The bit corresponding to the unique device number register is pre-programmed to ensure the unique device number register is permanently protected against modification. The second protection lock register contains OTP bits that correspond the protection state each of the remaining 16 registers.

Platform Flash XL is available in a 10 × 13 mm, 1.0 mm-pitch FT64 package and supplied with all the bits erased (set to '1').

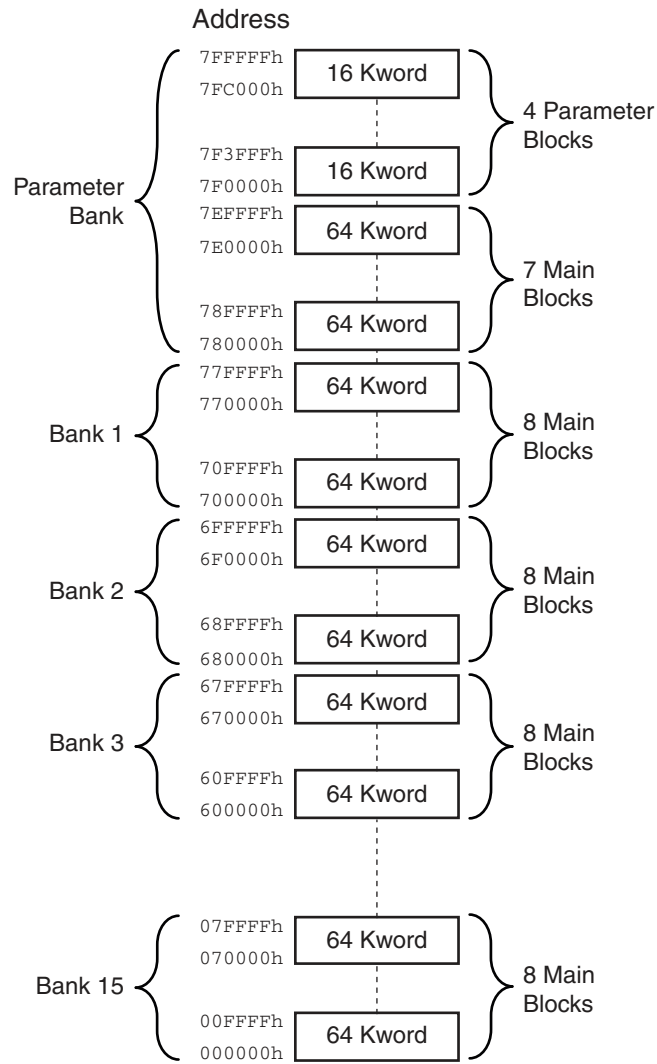

DS167_04_053008

Figure 4: Platform Flash XL Memory Map (Address Lines A22 – A0)

Pinout and Signal Descriptions

See Figure 5 and Table 2 for a logic diagram and brief overview of the signals connected to this device.

Table 2: Signal Names

Signal Name	Function	Direction
A22-A0	Address Inputs	Inputs
DQ15-DQ0	Data Input/Outputs, Command Inputs	I/O
\bar{E}	Chip Enable	Input
\bar{G}	Output Enable	Input
\bar{W}	Write Enable	Input
\bar{RP}	Reset	Input
\bar{WP}	Write Protect	Input
K	Clock	Input
\bar{L}	Latch Enable	Input
READY_WAIT	Ready/Wait	I/O
V _{DD}	Supply Voltage	—
V _{DDQ}	Supply Voltage for Input/Output Buffers	—
V _{PP}	Optional ⁽¹⁾ Supply Voltage for Fast Program and Erase	—
V _{SS}	Ground	—
V _{SSQ}	Ground Input/output Supply	—
NC	Not Connected Internally	—

Notes:

- Typically, V_{PP} is tied to the V_{DDQ} supply on a board. See the V_{PP} Program Supply Voltage section for alternate options.

Address Inputs (A22-A0)

The Address inputs select the words in the memory array to access during Bus Read operations. During Bus Write operations they control the commands sent to the Command Interface of the Program/Erase Controller.

Data Inputs/Outputs (DQ15-DQ0)

The Data I/O output the data stored at the selected address during a Bus Read operation or input a command or the data to be programmed during a Bus Write operation.

Chip Enable (\bar{E})

The Chip Enable input activates the memory control logic, input buffers, decoders and sense amplifiers. When Chip Enable is at V_{IL} and Reset is at V_{IH}, the device is in active mode. When Chip Enable is at V_{IH}, the memory is

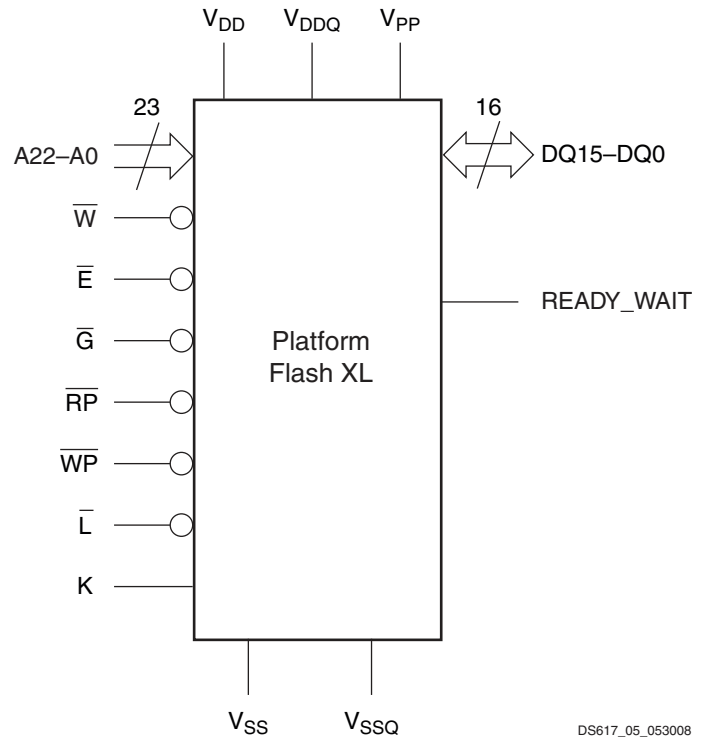

Figure 5: Logic Diagram

DS617_05_053008

deselected, the outputs are high impedance, and the power consumption is reduced to the standby level.

Output Enable (\bar{G})

The Output Enable input controls data outputs during the Bus Read operation of the memory. Before the start of the first address latching sequence (FALS), the Output Enable input must be held Low before the clock starts toggling.

Write Enable (\bar{W})

The Write Enable input controls the Bus Write operation of the memory's Command Interface. The data and address inputs are latched on the rising edge of Chip Enable or Write Enable, whichever occurs first.

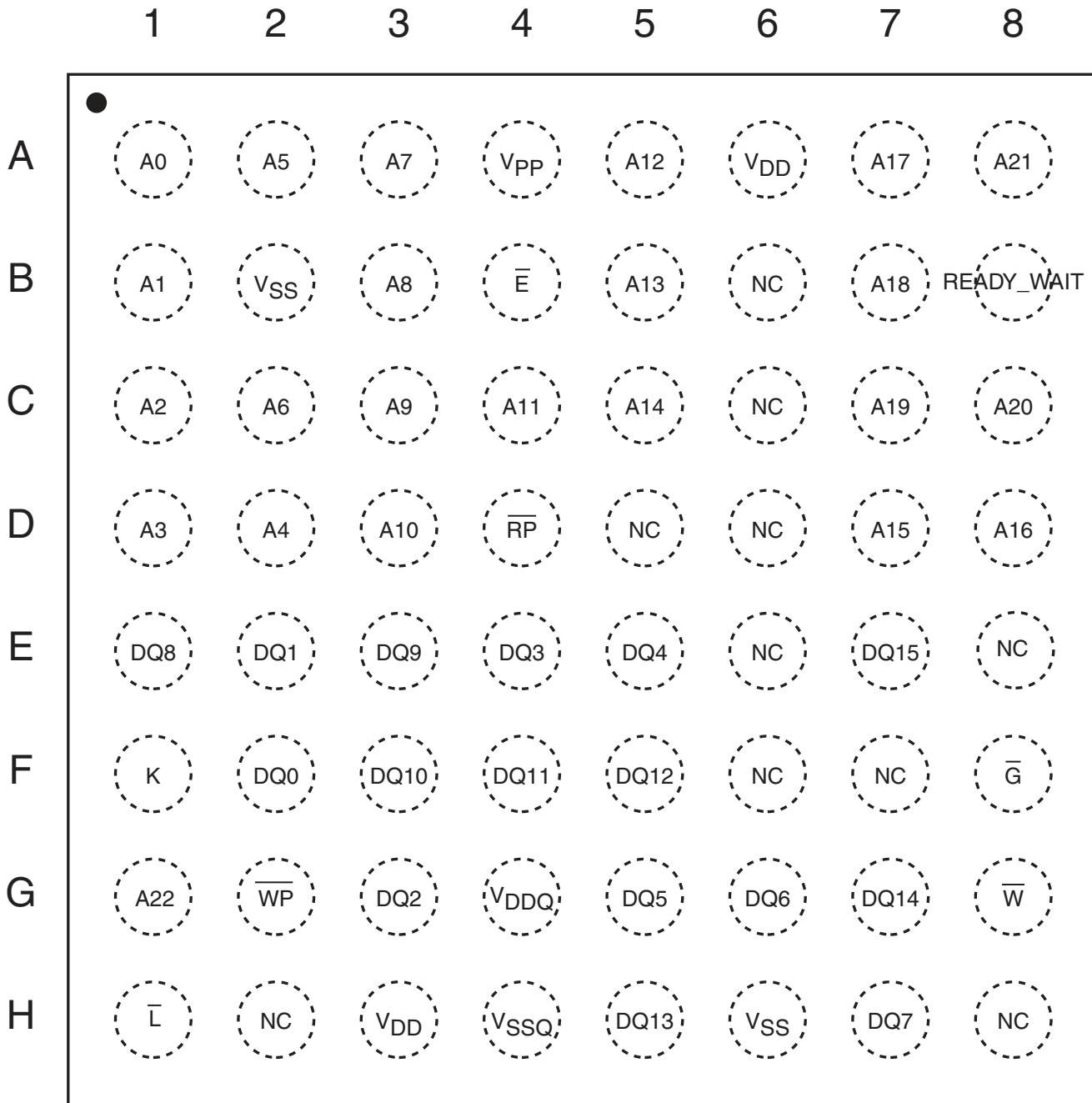

DS617_10_110807

Notes:

1. See the FT64/FTG64 package specifications at http://www.xilinx.com/support/documentation/package_specifications.htm.

Figure 6: FT64 Package Connections (Top View through Package)

Write Protect (\bar{W}_P)

Write Protect is an input that gives an additional hardware protection for each block. When Write Protect is at V_{IL}, the Lock-Down is enabled, and the protection status of the Locked-Down blocks cannot be changed. When Write Protect is at V_{IH}, the Lock-Down is disabled, and the Locked-Down blocks can be locked or unlocked.

Reset (\bar{R}_P)

The Reset input provides a hardware reset of the memory. When Reset is at V_{IL}, the memory is in reset mode: the outputs are high impedance, and the current consumption is reduced to the Reset supply current I_{DD2}. After Reset all blocks are in the Locked state, and the Configuration Register is reset. When Reset is at V_{IH}, the device is in normal operation. Exiting reset mode the device enters the synchronous read mode and the FALS is executed.

Latch Enable (\bar{L})

Latch Enable latches the address bits on its rising edge. The address latch is transparent when Latch Enable is at V_{IL} and inhibited when Latch Enable is at V_{IH} .

The Latch Enable (\bar{L}) signal must be held at V_{IH} during the power-up phase, during the FALS restart phase and through the entire FALS.

In asynchronous mode, the address is latched on \bar{L} going High. or addresses are sent continuously if \bar{L} is held Low. During Write operations, \bar{L} can be tied Low (V_{IL}) to allow the addresses to flow through.

Table 3: Latch Enable Logic Levels in Synchronous and Asynchronous Modes

Operation	Asynchronous	Synchronous
Bus Read	X	V_{IH}
Bus Write	X or toggling	X or toggling
Address Latch	Toggling	Toggling
Standby	X	X
Reset	V_{IH}	V_{IH}
FALS	V_{IH}	V_{IH}
Power-up	V_{IH}	V_{IH}

Notes:

1. See waveforms in the "DC and AC Parameters" section for details.

Clock (K)

The Clock input synchronizes the memory to the FPGA during synchronous read operations. The address is latched on a Clock edge (rising or falling, according to the configuration settings) when Latch Enable is at V_{IL} . Clock is ignored during asynchronous read and in write operations.

Ready/Wait (READY_WAIT)

Caution! The READY_WAIT requires an external pull-up resistor to V_{DDQ} . The external pull-up resistor must be sufficiently strong to ensure a clean, Low-to-High transition within less than one microsecond (T_{RWRT}) when the READY_WAIT pin is released to a high-impedance state.

READY_WAIT can perform one of two functions. By default, READY_WAIT is an input/open-drain ready signal coordinating the initiation of the device's synchronous read operation with the start of an FPGA configuration sequence. Optionally, READY_WAIT can be dynamically configured as an output wait signal, indicating a wait condition during a synchronous read operation.

Upon a power-on reset (POR) or \overline{RP} -pin reset event, the device drives READY_WAIT to V_{IL} until the device is ready to initiate a synchronous read or receive a command. When the device reaches an internal ready state from a reset condition, READY_WAIT is released to a high-impedance state (an external pull-up resistor to V_{DDQ} is required to externally pull

the READY_WAIT signal to a valid input High). The device waits until the READY_WAIT input becomes a valid input High before permitting a synchronous read or accepting a command. Connecting the READY_WAIT to the FPGA INIT_B pin in a wired-and circuit creates a handshake coordinating the initiation of the device synchronous read with the start of the FPGA configuration sequence.

When READY_WAIT is an input/open-drain ready signal, the system can drive READY_WAIT to V_{IL} to reinitiate a synchronous read operation. A valid address must be provided to the device for a reinitiated synchronous read operation.

Optionally, READY_WAIT can be configured as an output signaling a wait condition during a synchronous read operation. The wait condition indicates a clock cycle during which the output data is not valid. When configured as an output wait signal, READY_WAIT is high impedance when Chip Enable is at V_{IH} or Output Enable is at V_{IH} . Only when configured as a wait signal, READY_WAIT can be configured to be active during the wait cycle or one clock cycle in advance, and the READY_WAIT polarity can be configured.

V_{DD} Supply Voltage

V_{DD} provides the power supply to the internal core of the memory device and is the main power supply for all operations (Read, Program and Erase).

V_{DDQ} Supply Voltage

V_{DDQ} provides the power supply to the I/O pins and enables all outputs to be powered independently of V_{DD} .

V_{PP} Program Supply Voltage

V_{PP} is either a control input or a power supply pin, selected by the voltage range applied to the pin.

If V_{PP} is kept in a low voltage range (0V to V_{DDQ}), V_{PP} is seen as a control input. In this case a voltage lower than V_{PPLK} gives absolute protection against program or erase, while V_{PP} in the V_{PP1} range enables these functions. V_{PP} is only sampled at the beginning of a program or erase — a change in its value after the operation starts does not have any effect, and all program or erase operations continue.

If V_{PP} is in the range of V_{PPH} , the signal acts as a power supply pin. In this condition V_{PP} must be stable until the Program/Erase algorithm is completed.

V_{SS} Ground

V_{SS} Ground is the reference for the core supply and must be connected to the system ground.

V_{SSQ} Ground

V_{SSQ} Ground is the reference for the input/output circuitry driven by V_{DDQ} . V_{SSQ} must be connected to V_{SS} .

Note: Each device in a system should have V_{DD} , V_{DDQ} and V_{PP} decoupled with a 0.1 μ F ceramic capacitor close to the pin (high-frequency, inherently low-inductance capacitors should be placed

as close as possible to the package). The PCB track widths should be sufficient to carry the required V_{PP} program and erase currents.

FPGA Configuration Overview

Platform Flash XL enables the rich set of FPGA configuration features without additional glue logic. The device delivers the FPGA bitstream at power-on through a 16-bit data bus at data rates up to 800 Mb/s. The FPGA can also be configured from one of many design/revision bitstreams stored in the device. These revision bitstreams are accessed through the FPGA's MultiBoot addressing and fallback features available in specific system configurations with Platform Flash XL. For detailed descriptions of the FPGA configuration features and configuration procedure, refer to the respective FPGA configuration user guide.

At a high level, the general procedure for FPGA configuration from Platform Flash XL is as follows:

1. A system event, such as power-up, initiates the FPGA configuration process. The FPGA drives its INIT_B pin Low while it clears its configuration memory. The Platform Flash XL drives its READY_WAIT pin Low during its reset period.
2. When ready, the FPGA and Platform Flash XL release their respective INIT_B and READY_WAIT pins. An external resistor pulls the connected INIT_B-READY_WAIT signal from Low to High, synchronizing the start of the FPGA configuration process.
3. At the start of the configuration process, the FPGA samples its mode pins to determine its configuration mode. For Master BPI-Up mode, the FPGA outputs an address to read from the flash. For Slave SelectMAP mode, onboard resistors set the initial flash read address.
4. The Platform Flash XL latches the initial address from the FPGA or from onboard resistor settings into its internal address counter and the Platform Flash XL outputs the first 16-bit word.
5. The bitstream is synchronously transferred from the Platform Flash XL to the FPGA. During each successive FPGA CCLK period, the Platform Flash XL increments its internal address counter and outputs the next 16-bit word of the bitstream for the FPGA to consume.
6. At the end of the configuration process, the FPGA starts operation of the loaded bitstream and either drives DONE High or releases DONE to High, indicating the completion of the configuration procedure.

Platform Flash XL can configure the FPGA in Slave SelectMAP (x16) (recommended for maximum performance), Master SelectMAP (x16), or Master BPI-Up (x16) configuration mode. See [Table 4](#) for a summary of attributes for different configuration modes and memories.

Table 4: Overview of FPGA Configuration from Platform Flash XL and Standard BPI Flash

	Platform Flash XL		Third-Party Standard BPI Flash (110-ns Access Time)
	High-Performance Configuration Mode	Standard BPI Flash Compatibility Mode	
FPGA Configuration Mode	Slave SelectMAP mode (x16 data bus width)	Master BPI-Up mode (x16 data bus width)	Master BPI-Up mode (x16 data bus width)
Guaranteed Bitstream Transfer Bandwidth at Best Clock Setting	800 Mb/s ⁽¹⁾	248 Mb/s ⁽²⁾	78 Mb/s ⁽³⁾
Virtex-5 FPGA Support	✓	✓	✓
Virtex-6 FPGA Support	✓	✓	✓
ISE Software Programming Support	✓	✓	For limited setups ⁽⁴⁾
MultiBoot Capable	✓	✓	✓

Notes:

1. The 800 Mb/s rate is achieved using a Virtex-5 FPGA with an external 50 MHz configuration clock source. Specific speed grades of the Virtex-6 FPGA or system-level considerations can limit the configuration performance to less than 800 Mb/s.
2. Bandwidth is based on an example Virtex-5 FPGA considering $F_{MCKKTOL}$ and BitGen ConfigRate = 31 MHz (nominal frequency).
3. Bandwidth is based on an example Virtex-5 FPGA considering $F_{MCKKTOL}$ and BitGen ConfigRate = 17 MHz (nominal frequency), bpi_page_size = 4, and bpi_1st_read_cycle = 4. First word access time = 110 ns; Page word access time = 25 ns.
4. See [XAPP973](#), *Indirect Programming of BPI PROMs with Virtex-5 FPGAs*.

Slave SelectMAP Configuration Mode

Platform Flash XL achieves maximum configuration performance when the FPGA is in Slave SelectMAP configuration mode. In the Slave SelectMAP mode, a stable, external clock source can drive the synchronous bitstream transfer from the device to the FPGA up to the maximum burst read frequency (T_{CLK}). See the SelectMAP Configuration Interface section in the respective FPGA

Configuration User Guide for details of the Slave SelectMAP mode.

Note: The FPGA fallback feature is disabled in the Slave SelectMAP mode.

See [UG438](#), *Platform Flash XL Configuration and Storage Device User Guide*, for guidance and examples of FPGAs connected to a Platform Flash XL for Slave SelectMAP configuration mode.

Alternate Configuration Modes

Platform Flash XL is optimized for the Slave SelectMAP configuration mode. Alternatively, Platform Flash XL can configure an FPGA via the Master SelectMAP or Master BPI-Up mode—albeit with compromises in configuration speed. See the respective FPGA configuration user guide for details regarding the Master SelectMAP mode or Master BPI-Up mode.

See [UG438](#), *Platform Flash XL Configuration and Storage Device User Guide*, for additional information on using the Platform Flash XL with the FPGA in Master SelectMAP or Master BPI-Up mode.

Programming Overview

Programming solutions satisfying the requirements for each product phase are available for Platform Flash XL. ISE software provides integrated programming support for the FPGA design engineer in the prototyping environment. Third-party programming support is also available for the demands of the manufacturing environments.

iMPACT Programming Solution for Prototype FPGA Designs

Xilinx ISE software has integral support for in-system programming enabling rapid develop-program-and-test cycles for prototype FPGA designs. The software can compile the FPGA design into a configuration bitstream and program the bitstream into a Platform Flash XL in-system via a Xilinx JTAG cable (Figure 7).

The iMPACT software tool within the ISE software suite formats the FPGA user design bitstream into a flash memory image file and programs the device via a Xilinx JTAG cable connection to the JTAG port of the FPGA. For the programming process, the iMPACT software first downloads a pre-built bitstream containing an in-system programming engine into the FPGA. Then, the iMPACT software indirectly programs the FPGA user design bitstream into a Platform Flash XL via the downloaded in-system programming engine in the FPGA.

Note: For iMPACT software indirect in-system programming support, a specific set of connections is required between the FPGA and Platform Flash XL. See [UG438](#), *Platform Flash XL Configuration and Storage Device User Guide*, for recommended

connections. iMPACT supports reading and writing of only the main memory array. iMPACT does not support reading or writing of special data registers, for example, electronic signature codes, protection registers, or OTP registers.

Production Programming Solutions

For the requirements of manufacturing environments, multiple solutions exist for programming Platform Flash XL. Programming support is available for the common production programming platforms.

Note: Check with the third-party vendor for the availability of Platform Flash XL programming support.

Device Programmers

Device programmers can gang program a high volume of Platform Flash XL in an minimum of time. Third-party device programmer vendors, such as BPM Microsystems, support programming of Platform Flash XL.

See http://www.xilinx.com/support/programr/dev_sup.htm for a sample list of third-party programmer vendors supporting Platform Flash XL.

Device programmers require the array data in the form of a standard PROM formatted data file, such as MCS. The FPGA .bit file is not a valid data input format for third-party device programmers. See the *Platform Flash XL Configuration and Storage Device User Guide* for instructions on preparing a programming file.

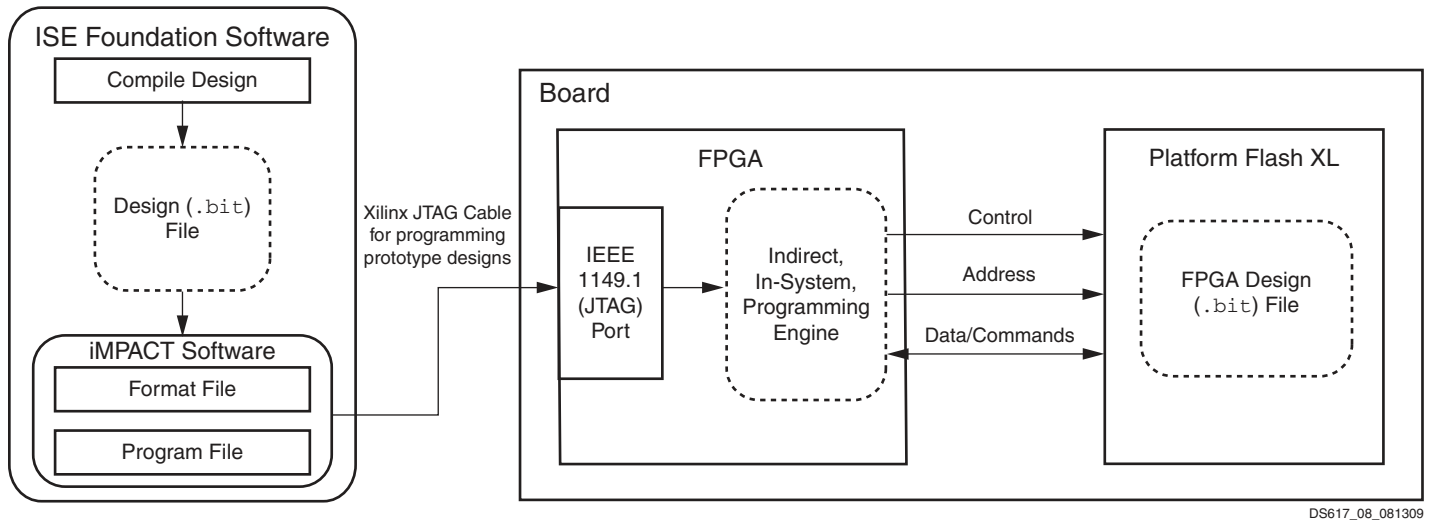

DS617_08_081309

Figure 7: Integrated FPGA Design and In-System Programming Solution for Platform Flash XL

Bus Operations

There are six standard bus operations that control the device: Bus Read, Bus Write, Address Latch, Output Disable, Standby and Reset (Table 5).

Bus Read

Bus Read operations are used to output the contents of the Memory Array, Electronic Signature, Status Register and Common Flash Interface. Both Chip Enable and Output Enable must be at V_{IL} in order to perform a read operation. The Chip Enable input should be used to enable the device. Output Enable should be used to gate data onto the output. The data read depends on the previous command written to the memory (see “Command Interface,” page 14).

Bus Write

Bus Write operations write commands to the memory or latch Input Data to be programmed. A Bus Write operation is initiated when Chip Enable and Write Enable are at V_{IL} with Output Enable at V_{IH} . Commands, Input Data and Addresses are latched on the rising edge of Write Enable or Chip Enable, whichever occurs first. The addresses can be latched prior to the write operation by toggling Latch Enable (when Chip Enable is at V_{IL}).

The Latch Enable signal can also be held at V_{IL} by the system, but then the system must guarantee that the address lines remain stable for at least T_{WHAX} .

Note: Typically glitches of less than 5 ns on Chip Enable or Write Enable are ignored by the memory and do not affect Bus Write operations.

Table 5: Bus Operations⁽¹⁾

Operation	\bar{E}	\bar{G}	\bar{W}	\bar{L}	\bar{RP}	READY_WAIT ^(2,3)		DQ15-DQ0
						CR4 = 1	CR4 = 0	
Bus Read	V_{IL}	V_{IL}	V_{IH}	$V_{IL}^{(4)}$	V_{IH}	Hi-Z	–	Data output
Bus Write	V_{IL}	V_{IH}	V_{IL}	$V_{IL}^{(4)}$	V_{IH}	Hi-Z	–	Data input
Address Latch	V_{IL}	X	V_{IH}	V_{IL}	V_{IH}	Hi-Z	–	Data output or Hi-Z ⁽⁵⁾
Output Disable	V_{IL}	V_{IH}	V_{IH}	X	V_{IH}	Hi-Z	Hi-Z	Hi-Z
Standby	V_{IH}	X	X	X	V_{IH}	Hi-Z	Hi-Z	Hi-Z
Reset	X	X	X	X	$V_{IL}^{(6)}$	$V_{IL}^{(7)}$	–	Hi-Z
FALS	V_{IL}	V_{IL}	V_{IH}	V_{IH}	V_{IH}	Hi-Z	–	Data output

Notes:

1. X = Don't care.
2. If READY_WAIT is configured as an output wait signal (CR4 = 0), then the CR10 Configuration Register bit defines the signal polarity.
3. READY_WAIT is configured using the CR4 Configuration Register bit.
4. \bar{L} can be tied to V_{IH} if the valid address was previously latched.
5. Depends on \bar{G} .
6. The Configuration Register reverts to its default value after a Low logic level (V_{IL}) is detected on the \bar{RP} pin.
7. READY_WAIT pin used as an output. READY_WAIT goes Low T_{PLRWL} after \bar{RP} goes Low.

Address Latch

Address latch operations input valid addresses. Both Chip enable and Latch Enable must be at V_{IL} during address latch operations. Addresses are latched on the rising edge of Latch Enable.

Output Disable

The outputs are held at high impedance when Output Enable is at V_{IH} .

Standby

Standby disables most of the internal circuitry allowing a substantial reduction of the current consumption. The memory is in standby when Chip Enable and Reset are at V_{IH} . Power consumption is reduced to the standby level I_{DD3} , and the outputs are set to high impedance independently from Output Enable or Write Enable. If Chip Enable switches to V_{IH} during a program or erase operation, the device enters Standby mode when finished with the program or erase operation.

Reset

During Reset mode, the memory is deselected and the outputs are high impedance. The memory is in Reset mode when Reset is at V_{IL} . Power consumption is reduced to the Reset level independently from Chip Enable, Output Enable or Write Enable. If Reset is pulled to V_{SS} during a Program or Erase, this operation is aborted and the memory content is no longer valid.

Command Interface

All Bus Write operations to the memory are interpreted by the Command Interface. Commands consist of one or more sequential Bus Write operations. An internal Program/Erase Controller handles all timings and verifies the correct execution of the program and erase commands. The Program/Erase Controller provides a Status Register whose output can be read at any time to monitor the progress or the result of the operation.

The Command Interface is set to synchronous read mode when power is first applied, when exiting from Reset, or whenever V_{DD} falls below its power-down threshold. Command sequences must be followed exactly — any invalid combination of commands are ignored.

Table 6 provides a summary of the Command Interface codes.

Table 6: Command Codes

Hex Code	Command
01h	Block Lock Confirm
03h	Set Configuration Register Confirm
10h	Alternative Program Setup
20h	Block Erase Setup
2Fh	Block Lock-Down Confirm
40h	Program Setup
50h	Clear Status Register
60h	Block Lock Setup, Block Unlock Setup, Block Lock Down Setup and Set Configuration Register Setup
70h	Read Status Register
80h	Buffer Enhanced Factory Program Setup
90h	Read Electronic Signature
98h	Read CFI Query
B0h	Program/Erase Suspend
BCh	Blank Check Setup
C0h	Protection Register Program
CBh	Blank Check Confirm
D0h	Program/Erase Resume, Block Erase Confirm, Block Unlock Confirm, Buffer Program or Buffer Enhanced Factory Program Confirm
E8h	Buffer Program
FFh	Read Array

Read Array Command

The Read Array command returns the addressed bank to Read Array mode. One Bus Write cycle is required to issue the Read Array command. After a bank is in Read Array mode, subsequent read operations output data from the memory array.

A Read Array command can be issued to any bank while programming or erasing in another bank. If the Read Array command is issued to a bank currently executing a program or erase operation, the bank returns to Read Array mode but the program or erase operation continues; however the data output from the bank is not guaranteed until the program or erase operation finishes. The read modes of other banks are not affected.

Read Status Register Command

The device contains a Status Register used to monitor program or erase operations.

The Read Status Register command is used to read the contents of the Status Register for the addressed bank. One Bus Write cycle is required to issue the Read Status Register command. After a bank is in Read Status Register mode, subsequent read operations output the contents of the Status Register.

The Status Register data is latched on the falling edge of Chip Enable or Output Enable. Either Chip Enable or Output Enable must be toggled to update the Status Register data.

The Read Status Register command can be issued at any time, even during program or erase operations. The Read Status Register command only changes the read mode of the addressed bank. The read modes of other banks are not affected. Only Asynchronous Read and Single Synchronous Read operations should be used to read the Status Register.

A Read Array command is required to return the bank to Read Array mode.

See Table 11, page 23 for the description of the Status Register Bits.

Read Electronic Signature Command

The Read Electronic Signature command is used to read the Manufacturer and Device Codes, Lock Status of the addressed bank, Protection Register, and Configuration Register. One Bus Write cycle is required to issue the Read Electronic Signature command. After a bank is in Read Electronic Signature mode, subsequent read operations in the same bank output the Manufacturer Code, Device Code, Lock Status of the addressed bank, Protection Register, or Configuration Register (see Table 10, page 22).

The Read Electronic Signature command can be issued at any time, even during program or erase operations, except during Protection Register Program operations. Dual operations between the Parameter bank and the Electronic Signature location are not allowed (see Table 17, page 36 for details).

If a Read Electronic Signature command is issued to a bank executing a program or erase operation, the bank enters

into Read Electronic Signature mode. Subsequent Bus Read cycles output Electronic Signature data, and the Program/Erase controller continues to program or erase in the background.

The Read Electronic Signature command only changes the read mode of the addressed bank. The read modes of other banks are not affected. Only Asynchronous Read and Single Synchronous Read operations should be used to read the Electronic Signature. A Read Array command is required to return the bank to Read Array mode.

Read CFI Query Command

The Read CFI Query command is used to read data from the Common Flash Interface (CFI). One Bus Write cycle is required to issue the Read CFI Query command. After a bank is in Read CFI Query mode, subsequent Bus Read operations in the same bank read from the Common Flash Interface. The Read CFI Query command can be issued at any time, even during program or erase operations.

If a Read CFI Query command is issued to a bank executing a program or erase operation, the bank enters into Read CFI Query mode. Subsequent Bus Read cycles output CFI data, and the Program/Erase controller continues to program or erase in the background.

The Read CFI Query command only changes the read mode of the addressed bank. The read modes of other banks are not affected. Only Asynchronous Read and Single Synchronous Read operations should be used to read from the CFI. A Read Array command is required to return the bank to Read Array mode. Dual operations between the Parameter Bank and the CFI memory space are not allowed (see [Table 17, page 36](#) for details).

See "[Appendix B: Common Flash Interface](#)," [page 65, Table 36, page 65](#), through [Table 45, page 70, Table 38, Table 38](#) for details on the information contained in the Common Flash Interface memory area.

Clear Status Register Command

The Clear Status Register command can be used to reset (set to '0') all error bits (SR1, 3, 4 and 5) in the Status Register. One Bus Write cycle is required to issue the Clear Status Register command. The Clear Status Register command does not affect the read mode of the bank.

The error bits in the Status Register do not automatically return to '0' when a new command is issued. The error bits in the Status Register should be cleared before attempting a new program or erase command.

Block Erase Command

The Block Erase command is used to erase a block. It sets all the bits within the selected block to '1'. All previous data in the block is lost.

If the block is protected, then the erase operation aborts, data in the block is not changed, and the Status Register outputs the error.

Two Bus Write cycles are required to issue the command.

- The first bus cycle sets up the Block Erase command.
- The second latches the block address and starts the Program/Erase Controller.

If the second bus cycle is not the Block Erase Confirm code, Status Register bits SR4 and SR5 are set and the command is aborted.

After the command is issued, the bank enters Read Status Register mode, and any read operation within the addressed bank outputs the contents of the Status Register. A Read Array command is required to return the bank to Read Array mode.

During Block Erase operations, the bank containing the block being erased only accepts the Read Array, Read Status Register, Read Electronic Signature, Read CFI Query, and Program/Erase Suspend command; all other commands are ignored.

The Block Erase operation aborts if Reset (\overline{RP}) goes to V_{IL} . As data integrity cannot be guaranteed when the Block Erase operation is aborted, the block must be erased again.

Refer to "[Dual Operations and Multiple Bank Architecture](#)," [page 35](#) for detailed information about simultaneous operations allowed in banks not being erased.

Typical Erase times are given in [Table 21, page 44](#).

See [Figure 41, page 75](#), for a suggested flowchart for using the Block Erase command.

Blank Check Command

The Blank Check command is used to check whether a Block is completely erased. Only one block at a time can be checked. To use the Blank Check command, V_{PP} must be equal to V_{PPH} . If V_{PP} is not equal to V_{PPH} , the device ignores the command and no error is shown in the Status Register.

Two bus cycles are required to issue the Blank Check command:

- The first bus cycle writes the Blank Check command (BCh) to any address in the block to be checked.
- The second bus cycle writes the Blank Check Confirm command (CBh) to any address in the block to be checked and starts the Blank Check operation.

If the second bus cycle is not Blank Check Confirm, Status Register bits SR4 and SR5 are set to '1', and the command aborts.

After the command is issued, the addressed bank automatically enters the Status Register mode and further reads within the bank output the Status Register contents.

The only operation permitted during Blank Check is Read Status Register. Dual Operations are not supported while a Blank Check operation is in progress. Blank Check operations cannot be suspended and are not allowed while the device is in Program/Erase Suspend.

The SR7 Status Register bit indicates the status of the Blank Check operation in progress:

- SR7 = '0' indicates that the Blank Check operation is still ongoing.
- SR7 = '1' indicates that the operation is complete.

The SR5 Status Register bit goes High (SR5 = '1') to indicate that the Blank Check operation has failed.

At the end of the operation the bank remains in the Read Status Register mode until another command is written to the Command Interface.

See [Figure 38, page 72](#), for a suggested flowchart for using the Blank Check command.

Typical Blank Check times are given in [Table 21, page 44](#).

Program Command

The program command is used to program a single word to the memory array. If the block being programmed is protected, then the Program operation aborts, data in the block is not changed, and the Status Register outputs the error.

Two Bus Write cycles are required to issue the Program Command.

- The first bus cycle sets up the Program command.
- The second latches the address and data to be programmed and starts the Program/Erase Controller.

After the programming starts, read operations in the bank being programmed output the Status Register content.

During a Program operation, the bank containing the word being programmed only accepts the Read Array, Read Status Register, Read Electronic Signature, Read CFI Query and Program/Erase Suspend command; all other commands are ignored. A Read Array command is required to return the bank to Read Array mode.

Refer to ["Dual Operations and Multiple Bank Architecture," page 35](#) for detailed information about simultaneous operations allowed in banks not being programmed.

Typical Program times are given in [Table 21, page 44](#).

The Program operation aborts if Reset (\overline{RP}) goes to V_{IL} . As data integrity cannot be guaranteed when the Program operation is aborted, the word must be reprogrammed.

See [Figure 37, page 71](#), for the flowchart for using the Program command.

Buffer Program Command

The Buffer Program Command makes use of the device's 32-word Write Buffer to speed up programming. Up to 32 words can be loaded into the Write Buffer. The Buffer Program command dramatically reduces in-system programming time compared to the standard non-buffered Program command.

Four successive steps are required to issue the Buffer Program command:

1. The first Bus Write cycle sets up the Buffer Program command. The setup code can be addressed to any location within the targeted block.
After the first Bus Write cycle, read operations in the bank output the contents of the Status Register. Status Register bit SR7 should be read to check that the buffer is available (SR7 = 1). If the buffer is not available (SR7 = 0), the Buffer Program command must be re-issued to update the Status Register contents.
2. The second Bus Write cycle sets up the number of words to be programmed. Value n is written to the same block address, where n + 1 is the number of words to be programmed.
3. A total of n + 1 Bus Write cycles are used to load the address and data for each word into the Write Buffer. Addresses must lie within the range from the start address to the start address + n, where the start address is the location of the first data to be programmed. Optimum performance is obtained when the start address corresponds to a 32-word boundary.
4. The final Bus Write cycle confirms the Buffer Program command and starts the program operation.

All the addresses used in the Buffer Program operation must lie within the same block. Invalid address combinations or failing to follow the correct sequence of Bus Write cycles sets an error in the Status Register and aborts the operation without affecting the data in the memory array.

If the block being programmed is protected, an error is set in the Status Register, and the operation aborts without affecting the data in the memory array.

During Buffer Program operations, the bank being programmed only accepts the Read Array, Read Status Register, Read Electronic Signature, Read CFI Query and Program/Erase Suspend command; all other commands are ignored.

Refer to ["Dual Operations and Multiple Bank Architecture," page 35](#) for detailed information about simultaneous operations allowed in banks not being programmed.

See [Figure 39, page 73](#), for a suggested flowchart on using the Buffer Program command.

Buffer Enhanced Factory Program Command

The Buffer Enhanced Factory Program command has been specially developed to speed up programming in manufacturing environments where the programming time is critical. The command is used to program one or more Write Buffer(s) of 32 words to a block. After the device enters Buffer Enhanced Factory Program mode, the Write Buffer can be reloaded any number of times as long as the address remains within the same block. Only one block can be programmed at a time.

If the block being programmed is protected, then the Program operation aborts, data in the block is not changed, and the Status Register outputs the error.

The use of the Buffer Enhanced Factory Program command requires certain operating conditions:

- V_{PP} must be set to V_{PPH} .
- V_{DD} must be within operating range.
- Ambient temperature T_A must be $30^{\circ}\text{C} \pm 10^{\circ}\text{C}$.
- The targeted block must be unlocked.
- The start address must be aligned with the start of a 32- word buffer boundary.
- The address must remain the Start Address throughout programming.

Dual operations are not supported during the Buffer Enhanced Factory Program operation, and the command cannot be suspended.

The Buffer Enhanced Factory Program Command consists of three phases: Setup, Program and Verify, and Exit (refer to [Table 8, page 21](#) for detail information).

Setup Phase

The Buffer Enhanced Factory Program command requires two Bus Write cycles to initiate the command:

- The first Bus Write cycle sets up the Buffer Enhanced Factory Program command.
- The second Bus Write cycle confirms the command.

After the confirm command is issued, read operations output the contents of the Status Register.

Caution! The read Status Register command must not be issued as it is interpreted as data to program.

The Status Register Program/Erase Controller (P/E.C). Bit SR7 should be read to check that the P/E.C. is ready to proceed to the next phase.

If an error is detected, SR4 goes High (set to '1') and the Buffer Enhanced Factory Program operation is terminated. See "[Status Register](#)," [page 23](#) for details on the error.

Program and Verify Phase

The Program and Verify Phase requires 32 cycles to program the 32 words to the Write Buffer. Data is stored sequentially, starting at the first address of the Write Buffer until the Write

Buffer is full (32 words). To program less than 32 words, the remaining words should be programmed with `FFFFh`.

Four successive steps are required to issue and execute the Program and Verify Phase of the command.

1. One Bus Write operation is used to latch the Start Address and the first word to be programmed. The Status Register Bank Write Status bit SR0 should be read to check that the P/E.C. is ready for the next word.
2. Each subsequent word to be programmed is latched with a new Bus Write operation. The address must remain the Start Address as the P/E.C. increments the address location. If any address not in the same block as the Start Address is given, the Program and Verify Phase terminates. Status Register bit SR0 should be read between each Bus Write cycle to check that the P/E.C. is ready for the next word.
3. After the Write Buffer is full, the data is programmed sequentially to the memory array. After the program operation, the device automatically verifies the data and reprograms if necessary.

The Program and Verify phase can be repeated without re-issuing the command to program an additional 32-word locations as long as the address remains in the same block.

4. Finally, after all words, or the entire block are programmed, one Bus Write operation must be written to any address outside the block containing the Start Address to terminate Program and Verify Phase.

Status Register bit SR0 must be checked to determine whether the program operation is finished. The Status Register can be checked for errors at any time but must be checked after the entire block is programmed.

Exit Phase

Status Register P/E.C. bit SR7 is set to '1' when the device exits the Buffer Enhanced Factory Program operation and returns to Read Status Register mode. A full Status Register check should be done to ensure that the block is successfully programmed. See "[Status Register](#)," [page 23](#) for more details.

For optimum performance, the Buffer Enhanced Factory Program command should be limited to a maximum of 100 program/erase cycles per block. If this limit is exceeded, the internal algorithm continues to work properly, but some degradation in performance is possible. Typical program times are given in [Table 21, page 44](#).

See [Figure 45, page 79](#), for a suggested flowchart on using the Buffer Enhanced Factory Program command.

Program/Erase Suspend Command

The Program/Erase Suspend command is used to pause a Program or Block Erase operation. The command can be addressed to any bank.

The Program/Erase Resume command is required to restart the suspended operation. One Bus Write cycle is required to issue the Program/Erase Suspend command. After the Program/Erase Controller pauses, bits SR7, SR6 and/or SR2 of the Status Register are set to '1'.

The following commands are accepted during Program/Erase Suspend:

- Program/Erase Resume
- Read Array (data from erase-suspended block or program-suspended word is not valid)
- Read Status Register
- Read Electronic Signature
- Read CFI Query

Additionally, if the suspended operation is a Block Erase, then the following commands are also accepted:

- Clear Status Register
- Program (except in erase-suspended block)
- Buffer Program (except in erase suspended blocks)
- Block Lock
- Block Lock-Down
- Block Unlock
- Set Configuration Register

During an erase suspend, the block being erased can be protected by issuing Block Lock or Block Lock-Down commands. When the Program/Erase Resume command is issued, the operation completes.

It is possible to accumulate multiple suspend operations. For example, suspend an erase operation, start a program operation, suspend the program operation, then read the array.

If a Program command is issued during a Block Erase Suspend, the erase operation cannot be resumed until the program operation is complete.

The Program/Erase Suspend command does not change the read mode of the banks. If the suspended bank is in Read Status Register, Read Electronic Signature or Read CFI Query mode, the bank remains in that mode and outputs the corresponding data.

Refer to "Dual Operations and Multiple Bank Architecture," page 35 for detailed information about simultaneous operations allowed during Program/Erase Suspend.

During a Program/Erase Suspend, the device can be placed in standby mode by taking Chip Enable to V_{IH} . Program/erase is aborted if Reset (\overline{RP}) goes to V_{IL} .

See Figure 40, page 74, and Figure 42, page 76, for flowcharts for using the Program/Erase Suspend command.

Program/Erase Resume Command

The Program/Erase Resume command is used to restart the program or erase operation suspended by the Program/Erase Suspend command. One Bus Write cycle is required to issue the command and can be issued to any address.

The Program/Erase Resume command does not change the read mode of the banks. If the suspended bank is in Read Status Register, Read Electronic Signature or Read CFI Query mode, the bank remains in that mode and outputs the corresponding data.

If a Program command is issued during a Block Erase Suspend, then the erase cannot be resumed until the program operation is complete.

See Figure 40, page 74, and Figure 42, page 76, for flowcharts for using the Program/Erase Resume command.

Protection Register Program Command

The Protection Register Program command is used to program the user one-time-programmable (OTP) segments of the Protection Register and the two Protection Register Locks.

The device features 16 OTP segments of 128 bits and one OTP segment of 64 bits (Figure 8, page 22). The segments are programmed one word at a time. When shipped, all bits in the segment are set to '1'. The user can only program the bits to '0'.

Two Bus Write cycles are required to issue the Protection Register Program command:

- The first bus cycle sets up the Protection Register Program command.
- The second latches the address and data to be programmed to the Protection Register and starts the Program/Erase Controller.

Read operations to the bank being programmed output the Status Register content after the program operation starts. Attempting to program a previously protected Protection Register results in a Status Register error.

The Protection Register Program cannot be suspended. Dual operations between the Parameter Bank and the Protection Register memory space are not allowed (see Table 17, page 36, for details).

The two Protection Register Locks are used to protect the OTP segments from further modification. The protection of the OTP segments is not reversible. Refer to Figure 8, page 22, and Table 10, page 22, for details on the Lock bits.

See Figure 44, page 78, for a flowchart for using the Protection Register Program command.

Set Configuration Register Command

The Set Configuration Register command is used to write a new value to the Configuration Register. Two Bus Write cycles are required to issue the Set Configuration Register command:

- The first cycle sets up the Set Configuration Register command and the address corresponding to the Configuration Register content.
- The second cycle writes the Configuration Register data and the confirm command.

The Configuration Register data must be written as an address during the bus write cycles, that is A0 = CR0, A1 = CR1, ..., A15 = CR15. Addresses A16–A22 are ignored. Read operations output the array content after the Set Configuration Register command is issued.

The Read Electronic Signature command is required to read the updated contents of the Configuration Register.

Block Lock Command

The Block Lock command is used to lock a block and prevent program or erase operations from changing the contents. All blocks are locked after power-up or reset.

Two Bus Write cycles are required to issue the Block Lock command:

- The first bus cycle sets up the Block Lock command.
- The second Bus Write cycle latches the block address and locks the block.

The lock status can be monitored for each block using the Read Electronic Signature command. [Table 18, page 38](#) shows the Lock Status after issuing a Block Lock command.

After being set, the Block Lock bits remain set even after a hardware reset or power-down/power-up. They are cleared by a Block Unlock command.

Refer to "[Block Locking](#)," [page 37](#) for a detailed explanation. See [Figure 43, page 77](#), for a flowchart for using the Lock command.

Block Unlock Command

The Block Unlock command is used to unlock a block, allowing the block to be programmed or erased.

Two Bus Write cycles are required to issue the Block Unlock command:

- The first bus cycle sets up the Block Unlock command.
- The second Bus Write cycle latches the block address and unlocks the block.

The lock status can be monitored for each block using the Read Electronic Signature command. [Table 18, page 38](#) shows the protection status after issuing a Block Unlock command.

Refer to the "[Block Locking](#)," [page 37](#) for a detailed explanation and [Figure 43, page 77](#), for a flowchart for using the Block Unlock command.

Block Lock-Down Command

The Block Lock-Down command is used to lock down a locked or unlocked block.

A locked-down block cannot be programmed or erased. The lock status of a locked-down block cannot be changed when \overline{WP} is Low (at V_{IL}). When \overline{WP} is High (at V_{IH}), the Lock-Down function is disabled, and the locked blocks can be individually unlocked by the Block Unlock command.

Two Bus Write cycles are required to issue the Block Lock-Down command:

- The first bus cycle sets up the Block Lock-Down command.
- The second Bus Write cycle latches the block address and locks-down the block.

The lock status can be monitored for each block using the Read Electronic Signature command.

Locked-Down blocks revert to the Locked (and not Locked-Down) state when the device is reset on power-down. [Table 18](#) shows the Lock Status after issuing a Block Lock-Down command.

Refer to "[Block Locking](#)," for a detailed explanation and [Figure 43](#), for a flowchart for using the Lock-Down command.

Table 7: Standard Commands⁽¹⁾

Commands	Cycles	Bus Operations					
		First Cycle			Second Cycle		
		Op.	Add.	Data	Op.	Add.	Data
Read Array	1+	Write	BKA	FFh	Read	WA	RD
Read Status Register	1+	Write	BKA	70h	Read	BKA ⁽²⁾	SRD
Read Electronic Signature	1+	Write	BKA	90h	Read	BKA ⁽²⁾	ESD
Read CFI Query	1+	Write	BKA	98h	Read	BKA ⁽²⁾	QD
Clear Status Register	1	Write	X	50h	–	–	–
Block Erase	2	Write	BKA or BA ⁽³⁾	20h	Write	BA	D0h
Program	2	Write	BKA or WA ⁽³⁾	40h or 10h	Write	WA	PD
Buffer Program ⁽⁴⁾	n+4	Write	BA	E8h	Write	BA	n
		Write	PA ₁	PD ₁	Write	PA ₂	PD ₂
		Write	PA _{n+1}	PD _{n+1}	Write	X	D0h
Program/Erase Suspend	1	Write	X	B0h	–	–	–
Program/Erase Resume	1	Write	X	D0h	–	–	–
Protection Register Program	2	Write	PRA	C0h	Write	PRA	PRD
Set Configuration Register	2	Write	CRD	60h	Write	CRD	03h
Block Lock	2	Write	BKA or BA ⁽³⁾	60h	Write	BA	01h
Block Unlock	2	Write	BKA or BA ⁽³⁾	60h	Write	BA	D0h
Block Lock-Down	2	Write	BKA or BA ⁽³⁾	60h	Write	BA	2FH

Notes:

1. X = Don't Care, WA = Word Address in targeted bank, RD =Read Data, SRD =Status Register Data, ESD = Electronic Signature Data, QD =Query Data, BA =Block Address, BKA = Bank Address, PD = Program Data, PA = Program address, PRA = Protection Register Address, PRD = Protection Register Data, CRD = Configuration Register Data.
2. Must be same bank as in the first cycle. The signature addresses are listed in [Table 9, page 21](#).
3. Any address within the bank can be used.
4. n+1 is the number of words to be programmed.

Table 8: Factory Commands

Command	Phase	Cycles	Bus Write Operations ⁽¹⁾										
			First		Second		Third		...	Final – 1		Final	
			Add.	Data	Add.	Data	Add.	Data		Add.	Data	Add.	Data
Blank Check		2	BA	BCh	BA	CbH	–	–	...	–	–	–	–
Buffer Enhanced Factory Program	Setup	2	BKA or WA ⁽²⁾	80h	WA ₁	D0h	–	–	...	–	–	–	–
	Program/Verify ⁽³⁾	≥32	WA ¹	PD ₁	WA ₁	PD ₂	WA ₁	PD ₃	...	WA ₁	PD ₃₁	WA ₁	PD ₃₂
	Exit	1	NOT BA ₁ ⁽⁴⁾	X	–	–	–	–	...	–	–	–	–

Notes:

1. WA = Word Address in targeted bank, BKA = Bank Address, PD = Program Data, BA = Block Address, X = Don't Care.
2. Any address within the bank can be used.
3. The Program/Verify phase can be executed any number of times as long as the data is to be programmed to the same block.
4. WA₁ is the Start Address, NOT BA₁ = Not Block Address of WA₁.

Table 9: Electronic Signature Codes

Code	Address (h)	Data (h)
Manufacturer Code	Bank Address + 000	0049
Device Code	Bank Address + 001	506B
Block Protection	Locked	0001
	Unlocked	0000
	Locked and Locked-Down	0003
	Unlocked and Locked-Down	0002
Configuration Register	Bank Address + 005	CR ⁽¹⁾
Protection Register PR0 Lock	Factory Default	0002
	OTP Area Permanently Locked	0000
Protection Register PR0	Bank Address + 081 Bank Address + 084	Unique Device Number
	Bank Address + 085 Bank Address + 088	OTP Area
Protection Register PR1 through PR16 Lock	Bank Address + 089	PRLD ⁽¹⁾
Protection Registers PR1–PR16	Bank Address + 08A Bank Address + 109	OTP Area

Notes:

1. CR = Configuration Register, PRLD = Protection Register Lock Data.
2. The iMPACT software does not support reading of the electronic signature codes.

Table 10: Protection Register Locks

Number	Lock		Description
	Address	Bits	
Lock 1	80h	bit 0	Preprogrammed to protect Unique Device Number, address 81h to 84h in PR0
		bit 1	Protects 64 bits of OTP segment, address 85h to 88h in PR0
		bits 2 to 15	Reserved
Lock 2	89h	bit 0	Protects 128 bits of OTP segment PR1
		bit 1	Protects 128 bits of OTP segment PR2
		bit 2	Protects 128 bits of OTP segment PR3
		–	–
		bit 13	Protects 128 bits of OTP segment PR14
		bit 14	Protects 128 bits of OTP segment PR15
		bit 15	Protects 128 bits of OTP segment PR16

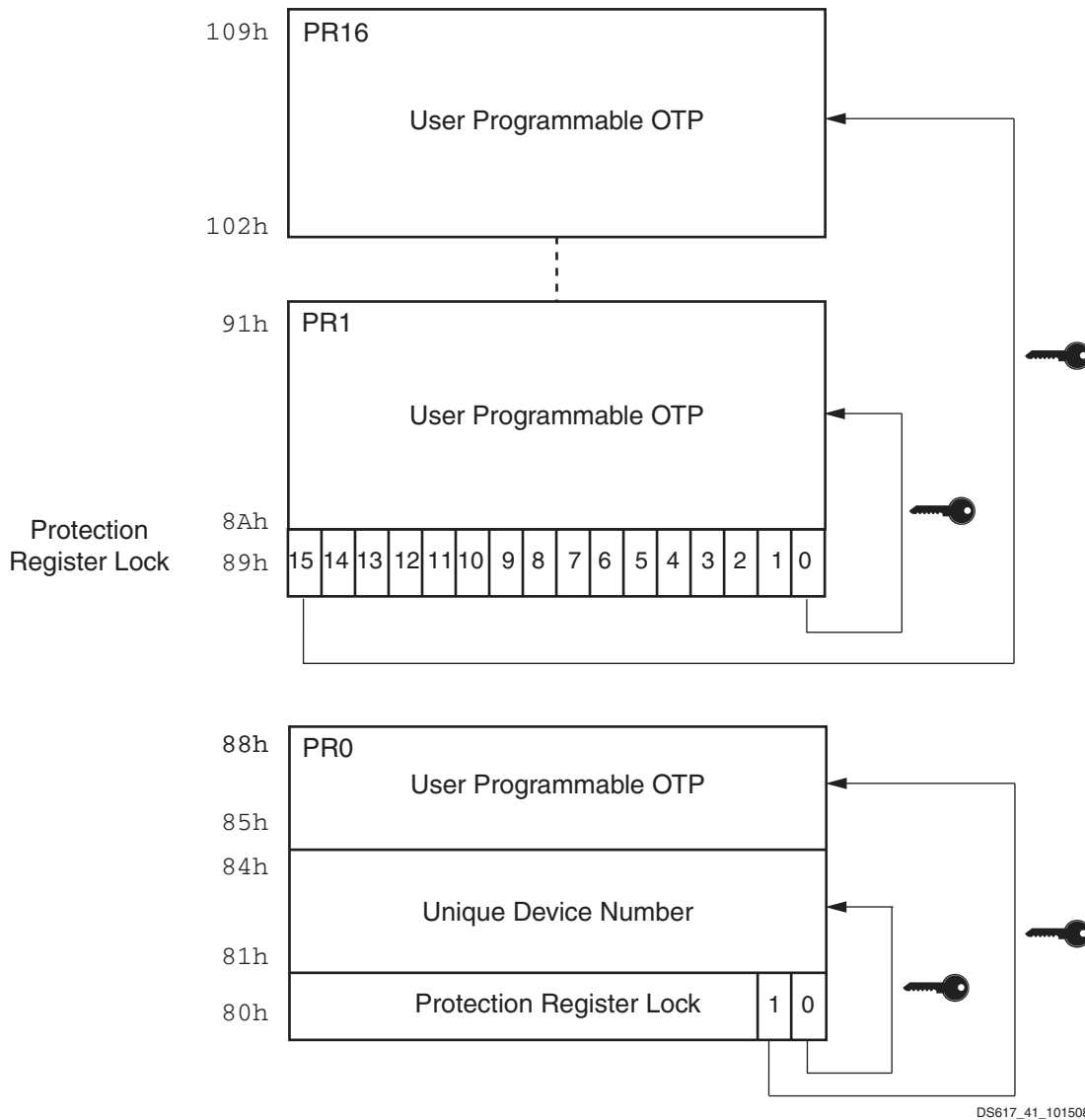

DS617_41_101508

Notes:

1. The iMPACT software does not support reading or writing of the protection register locks, OTP fields, or unique device number.

Figure 8: Protection Register Memory Map

Status Register

The Status Register provides information on the current or previous program or erase operations. A Read Status Register command is issued to read the contents of the Status Register, refer to "[Read Status Register Command](#)," [page 14](#) for more details. To output the contents, the Status Register is latched and updated on the falling edge of the Chip Enable or Output Enable signals and can be read until Chip Enable or Output Enable returns to V_{IH} .

The Status Register can only be read using single asynchronous or synchronous reads. Bus Read operations from any address within the bank always read the Status Register during program and erase operations if no Read Array command is issued.

The various bits convey information about the status and any errors of the operation. Bits SR7, SR6, SR2 and SR0 give information on the status of the device and are set and reset by the device. Bits SR5, SR4, SR3 and SR1 give information on errors and are set by the device but must be reset by issuing a Clear Status Register command or a hardware reset.

If an error bit is set to '1', the Status Register should be reset before issuing another command.

The bits in the Status Register are summarized in [Table 11](#).

Table 11: Status Register Bits

Bit	Name	Type	Logic Level ⁽¹⁾	Definition	
SR7	P/E.C. Status	Status	'1'	Ready	
			'0'	Busy	
SR6	Erase Suspend Status	Status	'1'	Erase suspended	
			'0'	Erase In progress or completed	
SR5	Erase/Blank Check Status	Error	'1'	Erase/blank check error	
			'0'	Erase/blank check success	
SR4	Program Status	Error	'1'	Program error	
			'0'	Program success	
SR3	V_{PP} Status	Error	'1'	V_{PP} invalid, abort	
			'0'	V_{PP} OK	
SR2	Program Suspend Status	Status	'1'	Program suspended	
			'0'	Program In progress or completed	
SR1	Block Protection Status	Error	'1'	Program/erase on protected block, abort	
			'0'	No operation to protected block	
SR0	Bank Write Status	Status	'1'	SR7 = '1'	Not allowed
				SR7 = '0'	Program or erase operation in a bank other than the addressed bank
			'0'	SR7 = '1'	No program or erase operation in the device
				SR7 = '0'	Program or erase operation in addressed bank
	Multiple Word Program Status (Buffer Enhanced Factory Program mode)	Status	'1'	SR7 = '1'	Not allowed
				SR7 = '0'	The device is NOT ready for the next Buffer loading or is going to exit the BEFP mode
			'0'	SR7 = '1'	The device has exited the BEFP mode
				SR7 = '0'	The device is ready for the next Buffer loading

Notes:

- Logic level '1' is High, '0' is Low.

Program/Erase Controller Status Bit (SR7)

The Program/Erase Controller Status bit indicates whether

the Program/Erase Controller is active or inactive in any bank. When this bit is Low (set to '0'), the Program/Erase

Controller is active; when the bit is High (set to '1'), the controller is inactive, and the device is ready to process a new command.

The Program/Erase Controller Status bit is Low immediately after a Program/Erase Suspend command was issued until the controller pauses. After the Program/Erase Controller pauses the bit is High.

Erase Suspend Status Bit (SR6)

The Erase Suspend Status bit indicates that an erase operation is suspended. When this bit is High (set to '1'), a Program/Erase Suspend command was issued and the memory is waiting for a Program/Erase Resume command.

The Erase Suspend Status bit should only be considered valid when the Program/Erase Controller Status bit is High (Program/Erase Controller inactive). SR6 is set within the Erase Suspend Latency time of the Program/Erase Suspend command being issued; therefore, the memory can still complete the operation rather than entering the Suspend mode.

When a Program/Erase Resume command is issued, the Erase Suspend Status bit returns Low.

Erase/Blank Check Status Bit (SR5)

The Erase/Blank Check Status bit is used to identify if an error occurred during a Block Erase operation. When this bit is High (set to '1'), the Program/Erase Controller applied the maximum number of pulses to the block and still failed to verify that it erased correctly.

The Erase/Blank Check Status bit should be read after the Program/Erase Controller Status bit is High (Program/Erase Controller inactive).

The Erase/Blank Check Status bit is also used to indicate whether an error occurred during the Blank Check operation. If the data at one or more locations in the block where the Blank Check command was issued is different from `FFFFh`, SR5 is set to '1'.

After set High, the Erase/Blank Check Status bit must be set Low by a Clear Status Register command or a hardware reset before a new erase command is issued; otherwise, the new command appears to fail.

Program Status Bit (SR4)

The Program Status bit is used to identify if there is an error during a program operation. This bit should be read after the Program/Erase Controller Status bit is High (Program/Erase Controller inactive).

When the Program Status bit is High (set to '1'), the Program/Erase Controller applied the maximum number of pulses to the word and still failed to verify that it programmed correctly.

Attempting to program a '1' to an already programmed bit while $V_{PP} = V_{PPH}$ also sets the Program Status bit High. If V_{PP} is different from V_{PPH} , SR4 remains Low (set to '0'), and the attempt is not shown.

After set High, the Program Status bit must be set Low by a Clear Status Register command or a hardware reset before a new program command is issued; otherwise, the new command appears to fail.

V_{PP} Status Bit (SR3)

The V_{PP} Status bit is used to identify an invalid voltage on the V_{PP} pin during program and erase operations. The V_{PP} pin is only sampled at the beginning of a program or erase operation. Program and erase operations are not guaranteed if V_{PP} becomes invalid during an operation.

When the V_{PP} Status bit is Low (set to '0'), the voltage on the V_{PP} pin was sampled at a valid voltage.

When the V_{PP} Status bit is High (set to '1'), the V_{PP} pin has a voltage below the V_{PP} Lockout Voltage (V_{PPLK}). The memory is protected and program and erase operations cannot be performed.

After set High, the V_{PP} Status bit must be set Low by a Clear Status Register command or a hardware reset before a new program or erase command is issued; otherwise, the new command appears to fail.

Program Suspend Status Bit (SR2)

The Program Suspend Status bit indicates that a program operation is suspended. This bit should only be considered valid when the Program/Erase Controller Status bit is High (Program/Erase Controller inactive).

When the Program Suspend Status bit is High (set to '1'), a Program/Erase Suspend command was issued, and the memory is waiting for a Program/Erase Resume command.

SR2 is set within the Program Suspend Latency time of the Program/Erase Suspend command being issued; therefore, the memory can still complete the operation rather than entering the Suspend mode.

When a Program/Erase Resume command is issued, the Program Suspend Status bit returns Low.

Block Protection Status Bit (SR1)

The Block Protection Status bit is used to identify if a Program or Block Erase operation tried to modify the contents of a locked or locked-down block. When this bit is High (set to '1'), a program or erase operation was attempted on a locked or locked-down block.

After set High, the Block Protection Status bit must be set Low by a Clear Status Register command or a hardware reset before a new program or erase command is issued; otherwise, the new command appears to fail.

Bank Write/Multiple Word Program Status Bit (SR0)

The Bank Write Status bit indicates whether the addressed bank is busy performing a write or is ready to accept a new write command (a program or erase command). In Buffer Enhanced Factory Program mode, the Multiple Word

Program bit shows if the device is ready to accept a new word to be programmed to the memory array.

The Bank Write Status bit should only be considered valid when the Program/Erase Controller Status SR7 is Low (set to '0').

When both the Program/Erase Controller Status bit and the Bank Write Status bit are Low (set to '0'), the addressed bank is executing a program or erase operation. When the Program/Erase Controller Status bit is Low (set to '0') and the Bank Write Status bit is High (set to '1'), a program or erase operation is being executed in a bank other than the one being addressed.

In Buffer Enhanced Factory Program mode, if Multiple Word Program Status bit is Low (set to '0'), the device is ready for the next word; if the Multiple Word Program Status bit is High (set to '1') the device is not ready for the next word.

For further details on how to use the Status Register, see the Flowcharts and Pseudocodes provided in "[Appendix C: Flowcharts and Pseudocodes](#)," page 71.

Configuration Register

The Configuration Register is used to configure the type of bus access that the memory performs. Refer to "Read Modes," page 34 for details on read operations.

The Configuration Register is set through the Command Interface using the Set Configuration Register command. After a reset or power-up, the device is configured for Synchronous Read (CR15 = 0). The Configuration Register bits (Table 12, page 26) specify the selection of the burst length, burst type, burst X latency, and read operation. Refer to Figure 9, page 28 and Figure 10, page 30 for examples of synchronous burst configurations.

Table 12: Configuration Register Bits

Bits	Description	Value	Description
CR15	Read mode	0	Synchronous Read (default)
		1	Asynchronous Read
CR14	Reserved	0	
CR13–CR11	Clock Latency	010	2 clock latency ⁽¹⁾
		011	3 clock latency
		100	4 clock latency
		101	5 clock latency
		110	6 clock latency
		111	7 clock latency (default)
		Other configurations reserved	
CR10	Wait Polarity	0	READY_WAIT with Wait function (CR4 = 0) is active Low
		1	READY_WAIT with Wait function (CR4 = 0) is active High (default)
CR9	Data output configuration	0	Data held for 1 clock cycle (default)
		1	Data held for 2 clock cycles ⁽¹⁾
CR8	Wait Configuration	0	Wait active during wait state
		1	Wait active 1 clock cycle before wait state (default)
CR7	Burst Type	0	Reserved
		1	Sequential (default)
CR6	Valid Clock Edge	0	Falling clock edge
		1	Rising clock edge (default)
CR5	Reserved	0	–
CR4	Device_ready	0	READY_WAIT signal has the Wait function
		1	READY_WAIT signal has the Ready function (default)
CR3 ⁽²⁾	Wrap burst	0	Wrap
		1	No wrap (default)
CR2–CR0 ⁽²⁾	Burst Length	001	4 words
		010	8 words
		011	16 words
		111	Continuous (default)

Notes:

1. The combination X-Latency = 2, Data held for two clock cycles and Wait active one data cycle before the WAIT state is not supported.
2. CR3 (wrap/no wrap) bit has no effect when CR2-CR0 (burst length) bits are set to continuous burst mode. Platform Flash XL wraps to the first memory address after the device outputs the data from the last memory address.

Read Mode Select Bit (CR15)

The Read Select bit, CR15, is used to switch between Asynchronous and Synchronous Read operations. When this bit is set to '1', read operations are asynchronous; when set to '0', read operations are synchronous.

Synchronous Burst Read is supported in both parameter and main blocks and can be performed across banks.

On reset or power-up, the Read Select bit is set to '0' for synchronous access.

X-Latency Bits (CR13-CR11)

The X-Latency bits are used during Synchronous Read operations to set the number of clock cycles between the address being latched and the first data becoming available (Figure 9). For correct operation the X-Latency bits can only assume the values listed in Table 12, page 26.

Table 13 shows how to set the X-Latency parameter, taking into account the speed class of the device and the frequency used to read the flash memory in synchronous mode.

Table 13: X-latency Settings

F _{MAX}	T _{Kmin}	X-Latency min
30 MHz	33 ns	3
40 MHz	25 ns	4
54 MHz	19 ns	5

Wait Polarity Bit (CR10)

The Wait Polarity bit is used to set the polarity of the READY_WAIT signal used in Synchronous Burst Read mode (with CR4 = 0). During this mode, the READY_WAIT signal indicates whether the data output is valid or a WAIT state must be inserted.

When the Wait Polarity bit is at '0', the READY_WAIT signal is active Low. When this bit is set to '1', the READY_WAIT signal is active High.

The CR10 Configuration Register bit becomes "don't care" if CR4 is set to '1', in which case the READY_WAIT pin behaves like a READY pin (default value).

Data Output Configuration Bit (CR9)

The Data Output Configuration bit is used to configure the output to remain valid for either one or two clock cycles during synchronous mode. When this bit is '0', the output data is valid for one clock cycle; when the bit is '1', the output data is valid for two clock cycles.

The Data Output Configuration must be configured using the following condition:

$$t_K > t_{KQV} + t_{QVK_CPU}$$

where:

t_K is the clock period

t_{QVK_CPU} is the data setup time required by the system CPU

t_{KQV} is the clock to data valid time.

If this condition is not satisfied, the Data Output Configuration bit should be set to '1' for two clock cycles (Figure 9, page 28).

Wait Configuration Bit (CR8)

The Wait Configuration bit is used to control the timing of the READY_WAIT signal when configured as an output with the Wait function (in Synchronous Burst Read mode).

When READY_WAIT is asserted, data is not valid; when READY_WAIT is deasserted, data is valid.

When the Wait Configuration bit is Low (reset to '0'), the READY_WAIT signal (configured as an output with the Wait function) is asserted during the WAIT state. When the Wait Configuration bit is High (set to '1'), the READY_WAIT output pin is asserted one data cycle before the WAIT state.

Burst Type Bit (CR7)

The Burst Type bit determines the sequence of addresses read during Synchronous Burst Read operations. This bit is High (set to '1') as the memory outputs from sequential addresses only.

See Table 14, page 29, for the sequence of addresses output from a given starting address in sequential mode.

Valid Clock Edge Bit (CR6)

The Valid Clock Edge bit (CR6) is used to configure the active edge of the Clock (K) during synchronous read operations. When this bit is Low (set to '0'), the falling edge of the Clock is the active edge; when High (set to '1'), the rising edge of the Clock is the active edge.

READY_WAIT Bit (CR4)

The READY_WAIT Configuration Register bit is a user-configurable bit. The default value is '1', where the READY_WAIT signal is configured as an input with the Ready function (CR4 = '1'). This particular configuration allows the use of the READY_WAIT signal for handshaking during the configuration sequence and during a Reset (\overline{RP}) pulse as the device holds the pin Low until the entire internal configuration of the device finishes. With CR4 = 1, the external pin can also be used by the end user to retrigger the first address latching sequence (FALS), simply by applying a High, a Low, and then a High pulse on the READY_WAIT pin. See "First Address Latching Sequence," page 41.

When CR4 = '0', the READY_WAIT signal assumes the standard WAIT functionality.

Wrap Burst Bit (CR3)

The Wrap Burst bit (CR3) is used to select between wrap and no wrap. Synchronous burst reads can be confined inside the 4, 8 or 16-word boundary (wrap) or overcome the boundary (no wrap). When this bit is Low (set to '0'), the burst read wraps. When it is High (set to '1'), the burst read does not wrap.

Burst Length Bits (CR2-CR0)

The Burst Length bits are used to set the number of words to be output during a Synchronous Burst Read operation as result of a single address latch cycle. These bits can be set for 4 words, 8 words, 16 words or continuous burst, where all the words are read sequentially. In continuous burst mode, the burst sequence can cross bank boundaries.

In continuous burst mode, or 4, 8 or 16 words no-wrap, depending on the starting address, the device asserts the WAIT signal to indicate that a delay is necessary before the data is output.

If the starting address is shifted by 1, 2 or 3 positions from the four-word boundary, WAIT is asserted for 1, 2 or 3 clock cycles, respectively, when the burst sequence crosses the first 16-word boundary, to indicate that the device needs an internal delay to read the successive words in the array. WAIT is asserted only once during a continuous burst access. See also [Table 14, page 29](#).

CR14 and CR5 are reserved for future use.

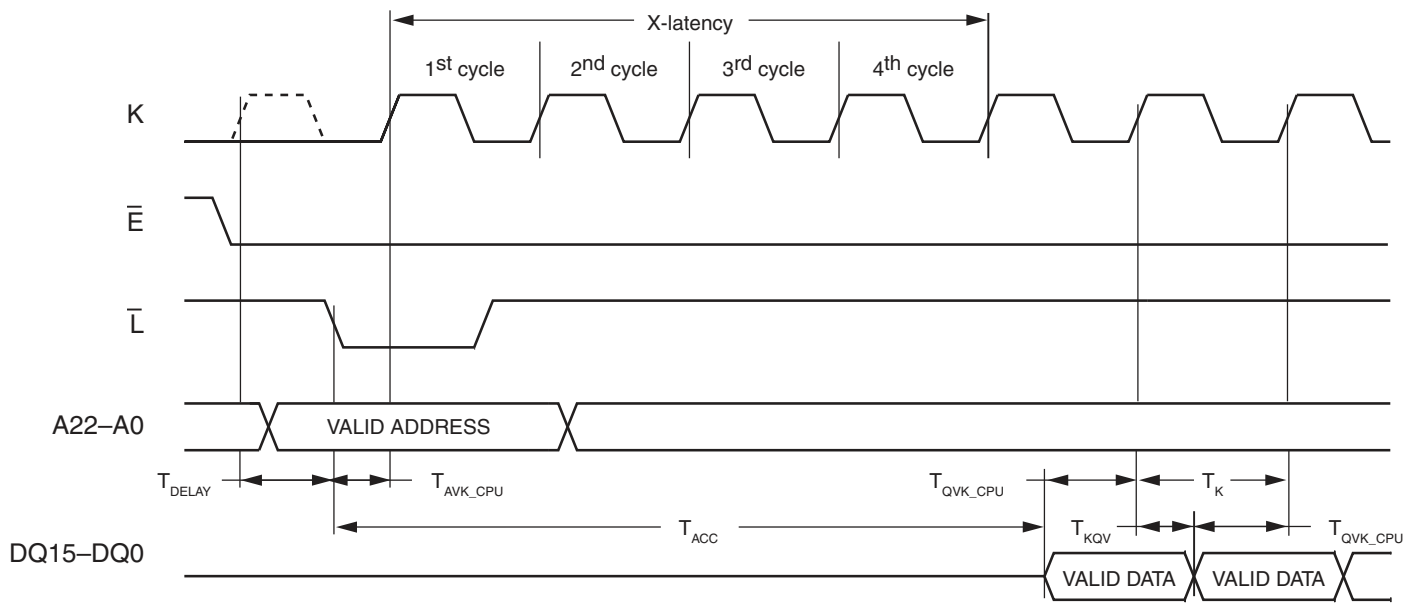

DS617_42_032508

Figure 9: X-Latency and Data Output Configuration Example

Table 14: Burst Type Definition

Mode	Start Address	Sequence			Continuous Burst
		4 Words	8 Words	16 Words	
Wrap	0	0-1-2-3	0-1-2-3-4-5-6-7	0-1-2-3-4-5-6-7-8-9-10-11-12-13-14-15	0-1-2-3-4-5-6...
	1	1-2-3-0	1-2-3-4-5-6-7-0	1-2-3-4-5-6-7-8-9-10-11-12-13-14-15-0	1-2-3-4-5-6-7...15-WAIT-16-17-18...
	2	2-3-0-1	2-3-4-5-6-7-0-1	2-3-4-5-6-7-8-9-10-11-12-13-14-15-0-1	2-3-4-5-6-7...15-WAIT-WAIT-16-17-18...
	3	3-0-1-2	3-4-5-6-7-0-1-2	3-4-5-6-7-8-9-10-11-12-13-14-15-0-1-2	3-4-5-6-7...15-WAIT-WAIT-WAIT-16-17-18...
			...		
	7	7-4-5-6	7-0-1-2-3-4-5-6	7-8-9-10-11-12-13-14-15-0-1-2-3-4-5-6	7-8-9-10-11-12-13-14-15-WAIT-WAIT-WAIT-16-17..
			...		
	12				12-13-14-15-16-17-18...
	13				13-14-15-WAIT-16-17-18...
	14		-		14-15-WAIT-WAIT-16-17-18...
15				15-WAIT-WAIT-WAIT-16-17-18...	
No-Wrap	0	0-1-2-3	0-1-2-3-4-5-6-7	0-1-2-3-4-5-6-7-8-9-10-11-12-13-14-15	Same as for Wrap (Wrap /No Wrap has no effect on Continuous Burst)
	1	1-2-3-4	1-2-3-4-5-6-7-8	1-2-3-4-5-6-7-8-9-10-11-12-13-14-15-WAIT-16	
	2	2-3-4-5	2-3-4-5-6-7-8-9...	2-3-4-5-6-7-8-9-10-11-12-13-14-15-WAIT-WAIT-16-17	
	3	3-4-5-6	3-4-5-6-7-8-9-10	3-4-5-6-7-8-9-10-11-12-13-14-15-WAIT-WAIT-WAIT-16-17-18	
			...		
	7	7-8-9-10	7-8-9-10-11-12-13-14	7-8-9-10-11-12-13-14-15-WAIT-WAIT-WAIT-16-17-18-19-20-21-22	
			...		
	12	12-13-14-15	12-13-14-15-16-17-18-19	12-13-14-15-16-17-18-19-20-21-22-23-24-25-26-27	
	13	13-14-15-WAIT-16	13-14-15-WAIT-16-17-18-19-20	13-14-15-WAIT-16-17-18-19-20-21-22-23-24-25-26-27-28	
	14	14-15-WAIT-WAIT-16-17	14-15-WAIT-WAIT-16-17-18-19-20-21	14-15-WAIT-WAIT-16-17-18-19-20-21-22-23-24-25-26-27-28-29	
15	15-WAIT-WAIT-WAIT-16-17-18	15-WAIT-WAIT-WAIT-16-17-18-19-20-21-22	15-WAIT-WAIT-WAIT-16-17-18-19-20-21-22-23-24-25-26-27-28-29-30		

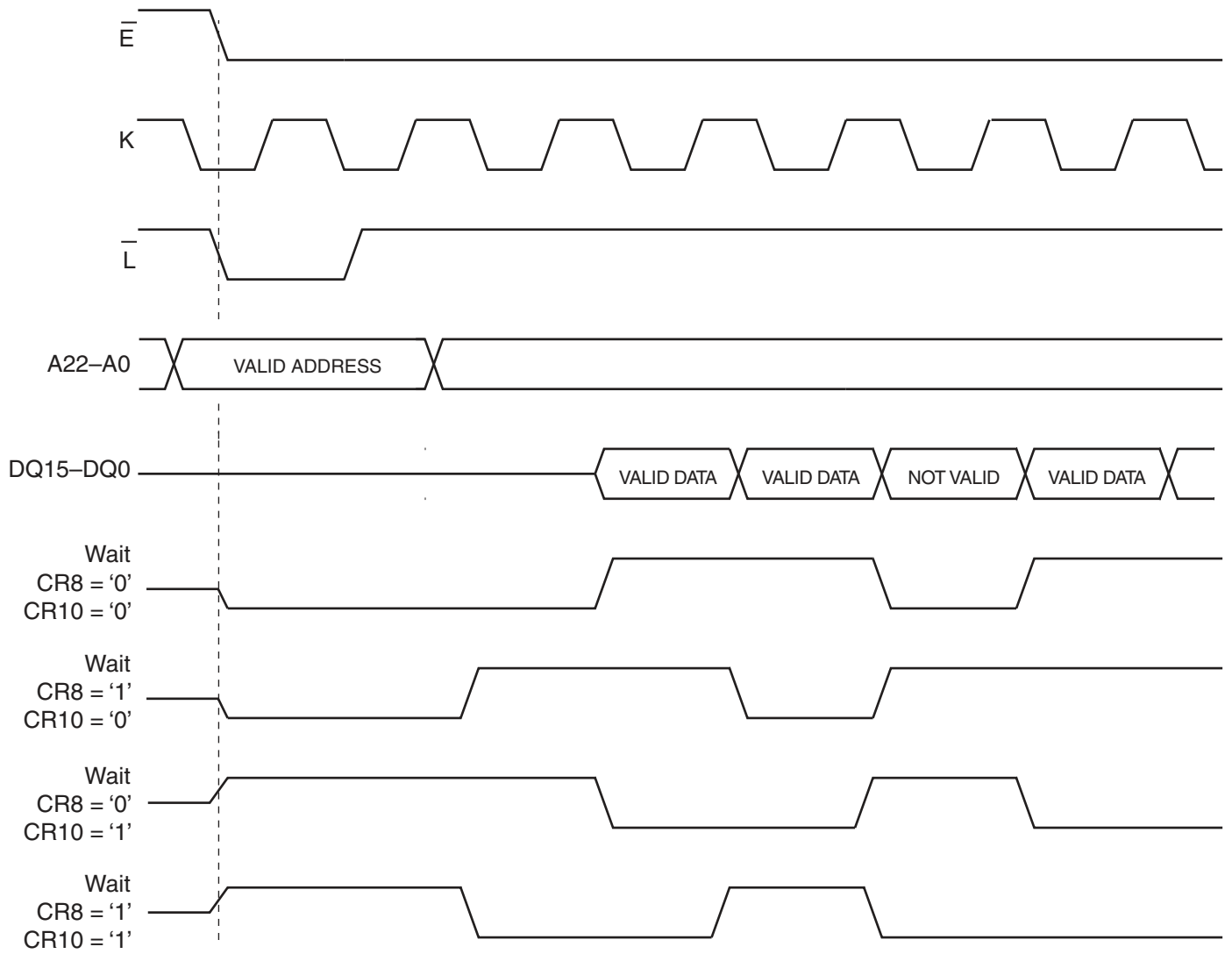

DS617_43_032508

Figure 10: Wait Application Example (CR4 = '0')

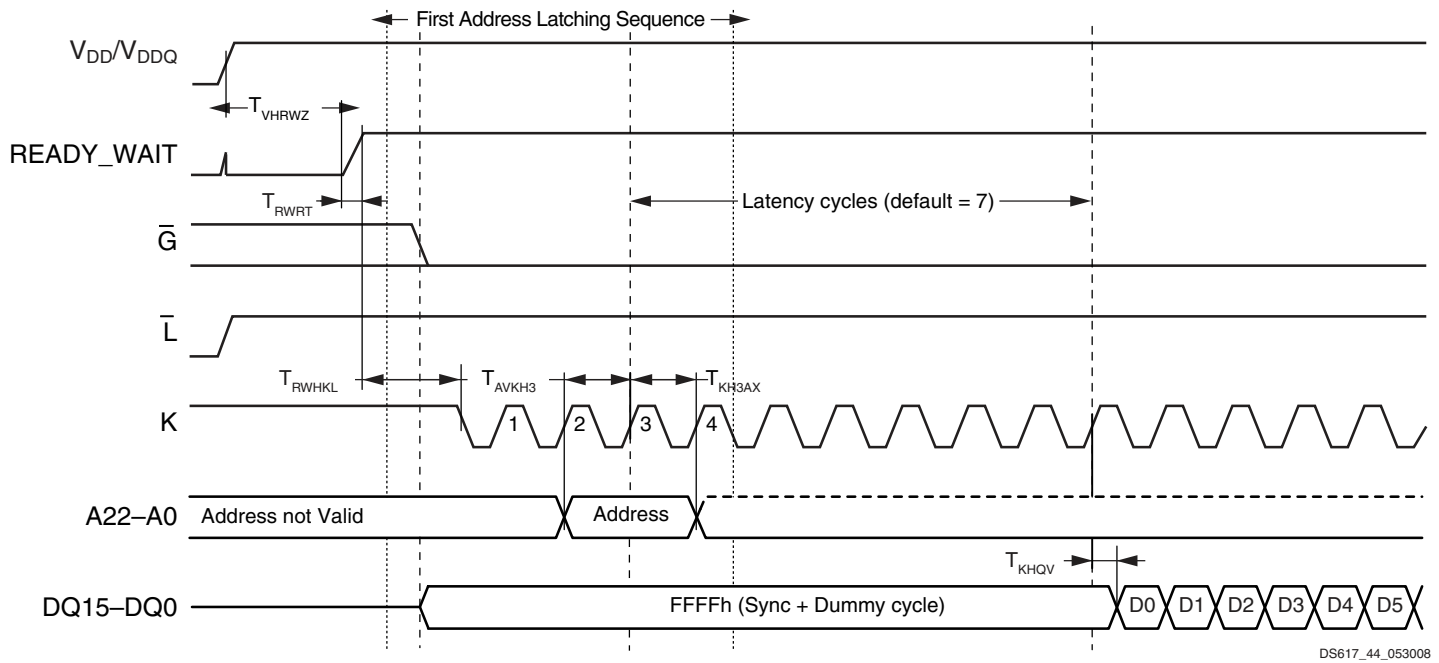

DS617_44_053008

Notes:

1. \overline{W} is tied High.
2. Address is latched on the third rising edge of K when \overline{G} and \overline{E} are Low, and \overline{L} and $\overline{RDY_WAIT}$ are High.
3. $\overline{RDY_WAIT}$ requires an external pull-up resistor to V_{DDQ} sufficiently strong to ensure a clean Low-to-High transition within less than T_{RWRT} when the $\overline{RDY_WAIT}$ pin is released to a high-impedance state.

Figure 11: Power-Up

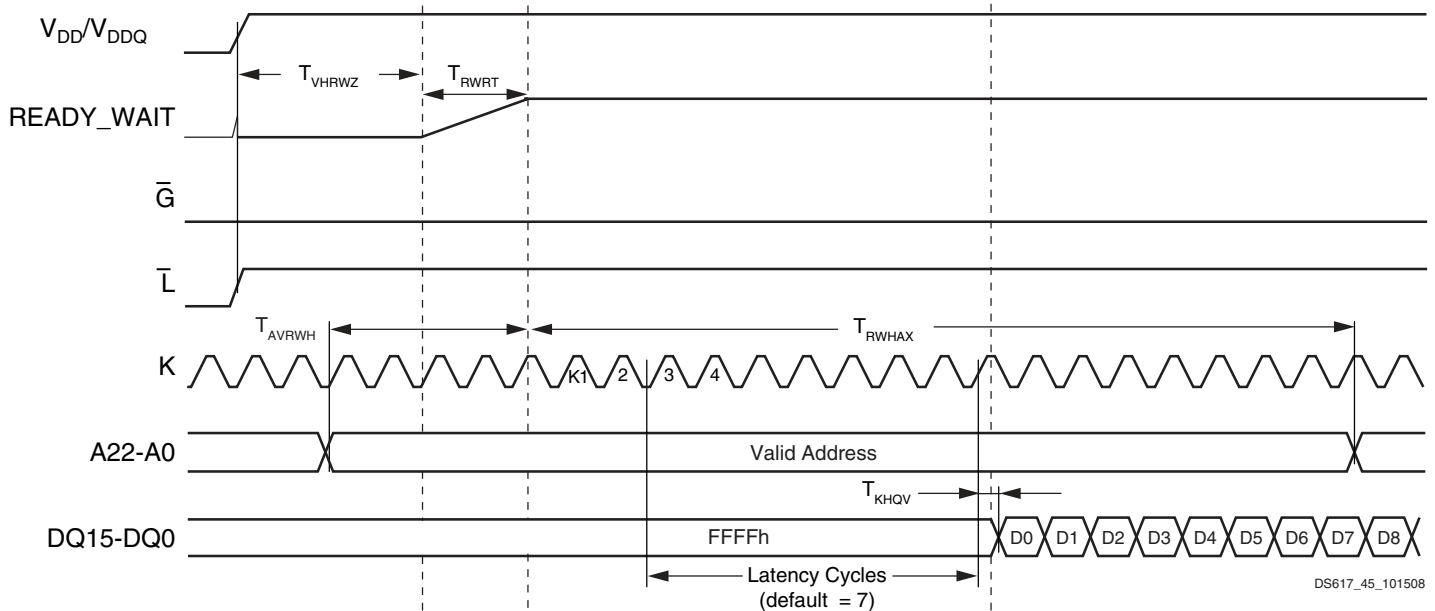

DS617_45_101508

Notes:

1. It is recommended to use the shown timings in the case of a free-running clock.
2. \overline{W} is tied High.
3. $K1$ is the first clock edge from which both the $\overline{RDY_WAIT}$ and the Output Enable signals are asserted ($\overline{RDY_WAIT}$ at V_{IH} and \overline{G} at V_{IL}).

Figure 12: Power-Up (Free-Running Clock)

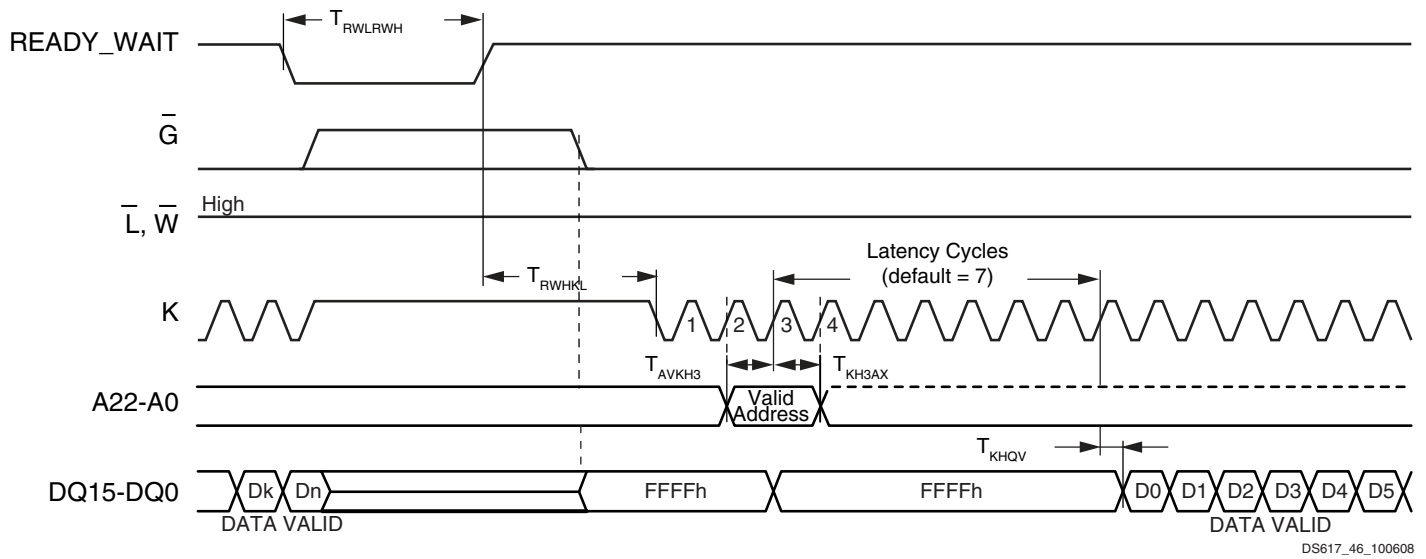

DS617_46_100608

Notes:

1. Dk and Dn indicate the Data valid after k and n clock cycles, respectively.
2. This figure applies when READY_WAIT (CR4) is configured with the Ready function.

Figure 13: READY_WAIT Pulse (Clock is not Free Running)

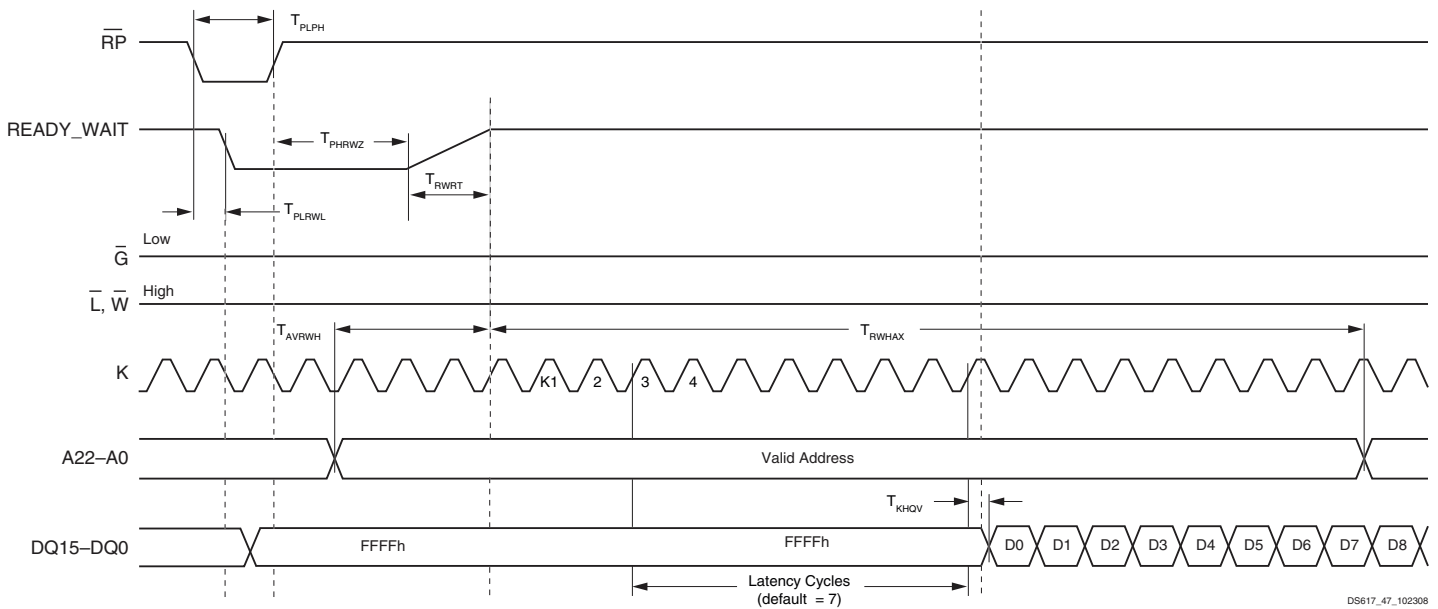

DS617_47_102308

Notes:

1. \bar{W} is tied High.
2. It is recommended to use the shown timings when the system has a free-running clock.
3. K1 is the first clock edge from which both the READY_WAIT and the Output Enable signals are asserted (READY_WAIT at V_{IH} and G at V_{IL}).
4. READY_WAIT requires an external pull-up resistor to V_{DDQ} sufficiently strong to ensure a clean Low-to-High transition within less than T_{RWRT} when the READY_WAIT pin is released to a high-impedance state.

Figure 14: READY_WAIT Pulse (Free-Running Clock)

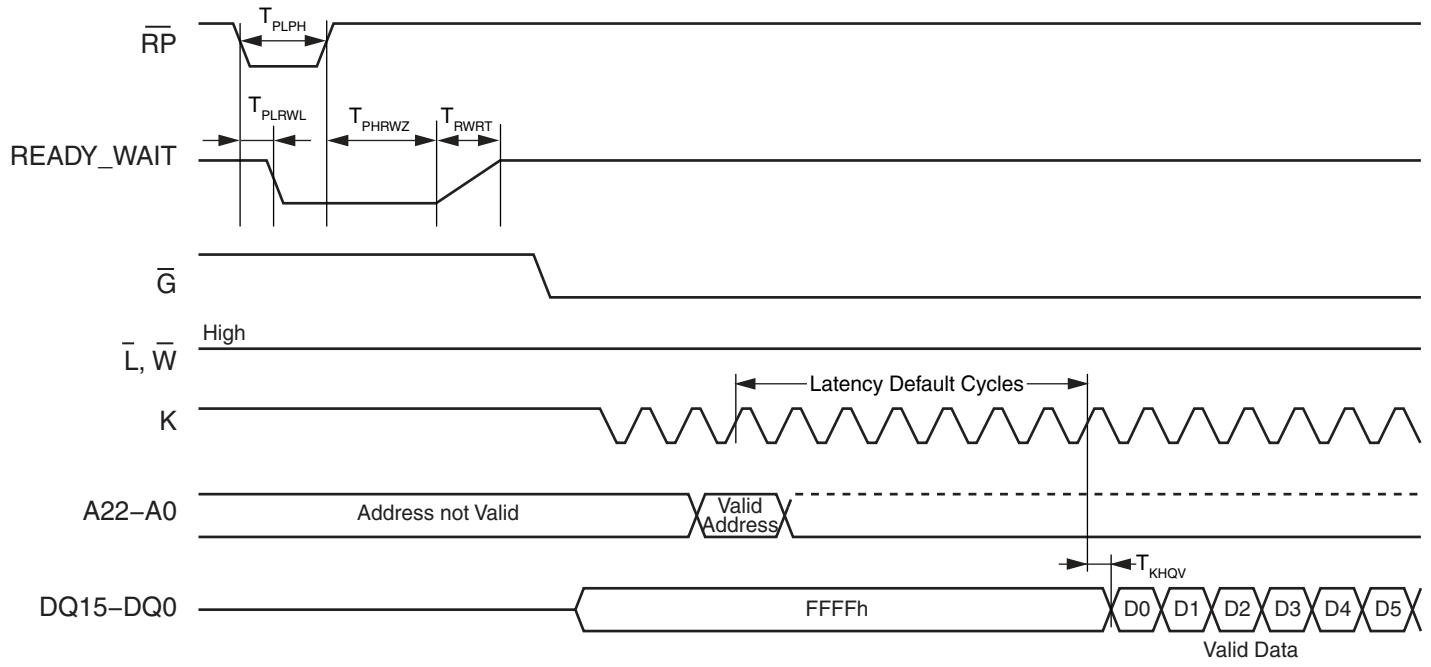

DS617_48_101508

Figure 15: \overline{RP} Pulse (Clock is not Free Running)

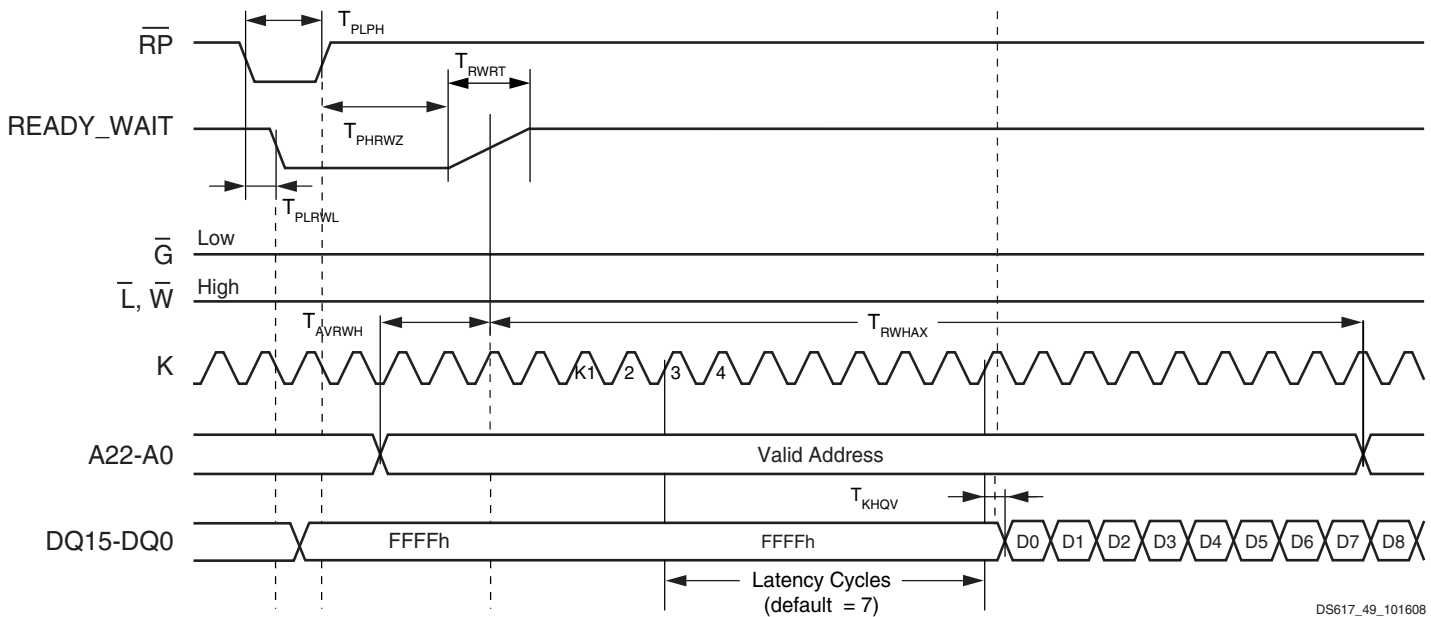

DS617_49_101608

Notes:

1. It is recommended to use the shown timings in the case of a free-running clock.
2. $K1$ is the first clock edge from which both the $\overline{READY_WAIT}$ and the Output Enable signals are asserted ($\overline{READY_WAIT}$ at V_{IH} and \overline{G} at V_{IL}).

Figure 16: \overline{RP} Pulse (Free Running Clock)

Read Modes

Read operations can be performed in two different ways depending on the settings in the Configuration Register. If the clock signal is 'don't care' for the data output, the read operation is asynchronous; if the data output is synchronized with clock, the read operation is also synchronous.

The read mode and format of the data output are determined by the Configuration Register (see "[Program/Erase Controller Status Bit \(SR7\)](#)," [page 23](#)). All banks support both asynchronous and synchronous read operations.

Asynchronous Read Mode

In Asynchronous Read operations, the clock signal is 'don't care'. Depending on the last command issued, the device outputs the memory array data corresponding to the latched address, the status register value, common flash interface value, or electronic signature.

Note: The Read Mode Select bit (CR15) in the Configuration Register must be set to '1' for asynchronous read mode operations.

Asynchronous Read operations can be performed in two different ways: Asynchronous Random Access Read and Asynchronous Page Read. Only Asynchronous Page Read takes full advantage of the internal page storage so different timings are applied. In Asynchronous Read mode a page of data is internally read and stored in a Page Buffer.

A page has a size of 4 words and is addressed by address inputs A0 and A1. The first read operation within the page has a longer access time (t_{AVQV} , Random Access Time), subsequent reads within the same page have much shorter access times (t_{AVQV1} , Page Access Time). If the page changes then the normal, longer timings apply again.

The device features an Automatic Standby mode. During Asynchronous Read operations, after a bus inactivity of 150 ns, the device automatically switches to the Automatic Standby mode. In this mode, the power consumption is reduced to the standby value and the outputs are still driven.

In Asynchronous Read mode, when the READY_WAIT signal is configured for the Wait function (CR4 = '0'), it is always deasserted.

See [Table 28, page 50](#), [Figure 25, page 48](#), and [Figure 26, page 49](#), for details.

Synchronous Burst Read Mode

In Synchronous Burst Read mode, the data is output in bursts synchronized with the clock. It is possible to perform burst reads across bank boundaries.

Synchronous Burst Read mode can only be used to read the memory array. For other read operations, such as Read Status Register, Read CFI, and Read Electronic Signature, Single Synchronous Read or Asynchronous Random Access Read must be used.

In Synchronous Burst Read mode, the flow of the data output depends on parameters configured in the Configuration Register.

A burst sequence starts at the first clock edge (rising or falling depending on Valid Clock Edge bit CR6 in the Configuration Register) after the falling edge of Latch Enable or Chip Enable, whichever occurs last. Addresses are internally incremented and data is output on each data cycle after a delay which depends on the X latency bits CR13-CR11 of the Configuration Register.

The number of words to be output during a Synchronous Burst Read operation can be configured as 4 words, 8 words, 16 words or continuous (Burst Length bits CR2-CR0). The data can be configured to remain valid for one or two clock cycles (Data Output Configuration bit CR9).

The order of the data output can be modified through the Wrap Burst bit in the Configuration Register. The burst sequence is sequential and can be confined inside the 4, 8 or 16 word boundary (Wrap) or overcome the boundary (No Wrap).

The READY_WAIT signal configured for the Wait function (CR4 = '0') can be asserted to indicate to the system that an output delay occurs. This delay depends on the starting address of the burst sequence and on the burst configuration.

READY_WAIT (with CR4 = '0') is asserted during the X latency, the WAIT state and at the end of a 4, 8 and 16-word burst. The signal is only de-asserted when output data is valid or when \bar{G} is at V_{IH} . In Continuous Burst Read mode, a WAIT state occurs when crossing the first 16-word boundary. If the starting address is aligned to the Burst Length (4, 8 or 16 words), the wrapped configuration has no impact on the output sequence.

The WAIT signal can be configured to be active Low or active High by setting CR10 in the Configuration Register.

See [Table 29, page 52](#): Synchronous Read ac characteristics, and [Figure 27, page 51](#): Synchronous Burst Read ac waveforms, CR4 = 0, for details.

Synchronous Burst Read Suspend

A Synchronous Burst Read operation can be suspended, freeing the data bus for other higher priority devices. The operation can be suspended during the initial access latency time (before data is output) or after the device has output data. When the Synchronous Burst Read operation is suspended, internal array sensing continues and any previously latched internal data is retained. A burst sequence can be suspended and resumed as often as required as long as the operating conditions of the device are met.

A Synchronous Burst Read operation is suspended when Chip Enable (\bar{E}) is Low and the current address is latched (on a Latch Enable rising edge, or on a valid clock edge).

The Clock signal is then halted at V_{IH} or at V_{IL} , and Output Enable (\bar{G}) goes High. When Output Enable goes Low again and the Clock signal restarts, the Synchronous Burst Read operation is resumed at its previous location.

When $READY_WAIT$ (with $CR4 = '0'$) is gated by \bar{E} , it reverts to high impedance when \bar{G} goes High.

See [Table 29, page 52](#), and [Figure 30, page 54](#) for details.

Single Synchronous Read Mode

Single Synchronous Read operations are similar to Synchronous Burst Read operations except that the memory outputs the same data to the end of the operation.

Dual Operations and Multiple Bank Architecture

The Multiple Bank Architecture of Platform Flash XL gives greater flexibility for software developers to split the code and data spaces within the memory array. The Dual Operations feature simplifies the software management of the device by allowing code to be executed from one bank while another bank is being programmed or erased. This feature allows read operations with zero latency in one bank while programming or erasing in another bank.

Note: Only one bank at a time is allowed to be in program or erase mode.

If a read operation is required in a bank which is programming or erasing, the program or erase operation can be suspended. Also if the suspended operation is erase, then a program command can be issued to another block so that the device can have one block in Erase

Synchronous Single Reads are used to read the Electronic Signature, Status Register, CFI, Block Protection Status, Configuration Register Status, or Protection Register. When the addressed bank is in Read CFI, Read Status Register, or Read Electronic Signature mode, the $READY_WAIT$ signal (if configured for the Wait function with $CR4 = '0'$) is asserted during X-latency, the WAIT state and at the end of a 4, 8 and 16-word burst. The signal is only deasserted when output data is valid. See [Table 29, page 52](#) and [Figure 27, page 51](#), for details.

Suspend mode, one in programming mode, and other banks in read mode.

Bus Read operations are allowed in other banks between setup and confirm cycles of program or erase operations.

By using a combination of these features, read operations are always possible in Platform Flash XL.

[Table 15](#) and [Table 16, page 35](#) show which dual operations are possible in other banks and in the same bank.

Dual operations between the Parameter Bank and either of the CFI, OTP, or Electronic Signature memory spaces are not allowed. [Table 17, page 36](#) shows which dual operations are allowed or not between the CFI, OTP, Electronic Signature locations and the memory array.

Table 15: Dual Operations Allowed in Another Bank

Status of Bank	Commands Allowed in Another Bank							
	Read Array	Read Status Register	Read CFI Query	Read Electronic Signature	Program, Buffer Program	Block Erase	Program/ Erase Suspend	Program/ Erase Resume
Idle	✓	✓	✓	✓	✓	✓	✓	✓
Programming	✓	✓	✓	✓	–	–	✓	–
Erasing	✓	✓	✓	✓	–	–	✓	–
Program Suspended	✓	✓	✓	✓	–	–	–	✓
Erase Suspended	✓	✓	✓	✓	✓	–	–	✓

Table 16: Dual Operations Allowed in Same Bank

Status of Bank	Commands Allowed in Same Bank							
	Read Array	Read Status Register	Read CFI Query	Read Electronic Signature	Program, Buffer Program	Block Erase	Program/ Erase Suspend	Program/ Erase Resume
Idle	✓	✓	✓	✓	✓	✓	✓	✓
Programming	–(1)	✓	✓	✓	–	–	✓	–
Erasing	–(1)	✓	✓	✓	–	–	✓	–

Table 16: Dual Operations Allowed in Same Bank (Cont'd)

Status of Bank	Commands Allowed in Same Bank							
	Read Array	Read Status Register	Read CFI Query	Read Electronic Signature	Program, Buffer Program	Block Erase	Program/ Erase Suspend	Program/ Erase Resume
Program Suspended	✓	✓	✓	✓	–	–	–	✓
Erase Suspended	✓	✓	✓	✓	✓	–	–	✓

Notes:

1. The Read Array command is accepted but the data output is not guaranteed until the Program or Erase has completed.
2. The Read Array command is accepted but the data output is not guaranteed in the Block that is being erased or the word being programmed.
3. Not allowed in the Block being erased or in the word being programmed.

Table 17: Dual Operation Limitations

Current Status		Commands Allowed			
		Read CFI / OTP / Electronic Signature	Read Parameter Blocks	Read Main Blocks	
				Located in Parameter Bank	Not Located in Parameter Bank
Programming / Erasing Parameter Blocks		–	–	–	✓
Programming / Erasing Main Blocks	Located in Parameter Bank	✓	–	–	✓
	Not Located in Parameter Bank	✓	✓	✓	In Different Bank Only
Programming OTP		–	–	–	–

Block Locking

Platform Flash XL features an instant, individual block-locking scheme, allowing any block to be locked or unlocked with no latency. This locking scheme has three levels of protection:

- Lock/Unlock – this first level allows software only control of block locking.
- Lock-Down – this second level requires hardware interaction before locking can be changed.
- $V_{PP} = V_{PPLK}$ – this third level offers a complete hardware protection against program and erase on all blocks.

The protection status of each block can be set to Locked, Unlocked, and Locked-Down. [Table 18, page 38](#), defines all of the possible protection states (\overline{WP} , DQ1, DQ0), and [Figure 43, page 77](#), shows a flowchart for the locking operations.

Reading a Block's Lock Status

The lock status of every block can be read during the Read Electronic Signature mode of the device (see "[Read Electronic Signature Command](#)," [page 14](#)). Subsequent reads at the address specified in [Table 9, page 21](#) output the protection status of that block.

The lock status is represented by DQ0 and DQ1. DQ0 indicates the Block Lock/Unlock status and is set by the Lock command and cleared by the Unlock command. DQ0 is automatically set when entering Lock-Down. DQ1 indicates the Lock-Down status and is set by the Lock-Down command. DQ1 cannot be cleared by software, only by a hardware reset or power-down.

Block Lock States

Locked State

The default status of all blocks on power-up or after a hardware reset is Locked (states (0,0,1) or (1,0,1)). Locked blocks are fully protected from program or erase operations. Any program or erase operations attempted on a locked block returns an error in the Status Register. The status of a locked block can be changed to Unlocked or Locked-Down using the appropriate software commands. An unlocked block can be Locked by issuing the Lock command.

Unlocked State

Unlocked blocks (states (0,0,0), (1,0,0) (1,1,0)) can be programmed or erased. All unlocked blocks return to the Locked state after a hardware reset or when the device is powered-down.

The status of an unlocked block can be changed to Locked or Locked-Down using the appropriate software commands. A locked block can be unlocked by issuing the Unlock command.

Locked-Down State

Blocks that are Locked-Down (state (0,1,x)) are protected from program and erase operations (similar to locked blocks) but their protection status cannot be changed using software commands alone. A locked or unlocked block can be locked down by issuing the Lock-Down command. Locked-down blocks revert to the Locked state when the device is reset or powered-down.

The Lock-Down function is dependent on the Write Protect (\overline{WP}) input pin. When $\overline{WP} = 0$ (V_{IL}), blocks in the Lock-Down state (0,1,x) are protected from program, erase and protection status changes.

When $\overline{WP} = 1$ (V_{IH}), the Lock-Down function is disabled (1,1,x), and locked-down blocks can be individually unlocked to the (1,1,0) state by issuing the software command to erase and programme.

When the Lock-Down function is disabled ($\overline{WP} = 1$), blocks can be locked (1,1,1) and unlocked (1,1,0) as desired. When $\overline{WP} = 0$, Blocks previously locked-down return to the Lock-Down state (0,1,x), regardless of any changes made while $\overline{WP} = 1$.

Device reset or power-down resets all blocks, including those in Locked-Down, to the Locked state.

Locking Operations during Erase Suspend

Changes to block lock status can be performed during a suspended erase by using standard locking command sequences to unlock, lock or lock-down a block. This capability is useful in the case when another block needs to be updated while an erase operation is in progress.

Three steps are needed to change block locking during an erase operation:

1. An Erase Suspend command is issued.
2. The Status Register is checked until it indicates that the erase operation is suspended.
3. The desired Lock command sequence is issued to a block (lock status changes).

After completing any desired lock, read, or program operations, the erase operation is resumed with the Erase Resume command.

If a block is locked or locked-down during a suspended erase of the same block, the locking status bits are changed immediately. But when the erase is resumed, the erase operation completes. Locking operations cannot be performed during a program suspend.

Table 18: Lock Status

Current Protection Status ⁽¹⁾ (\overline{WP} , DQ1, DQ0)			Next Protection Status ⁽¹⁾ (\overline{WP} , DQ1, DQ0)		
Current State	Program/Erase Allowed	After Block Lock Command	After Block Unlock Command	After Block Lock-Down Command	After \overline{WP} Transition
1,0,0	✓	1,0,1	1,0,0	1,1,1	0,0,0
1,0,1 ⁽²⁾	–	1,0,1	1,0,0	1,1,1	0,0,1
1,1,0	✓	1,1,1	1,1,0	1,1,1	0,1,1
1,1,1	–	1,1,1	1,1,0	1,1,1	0,1,1
0,0,0	✓	0,0,1	0,0,0	0,1,1	1,0,0
0,0,1 ⁽²⁾	–	0,0,1	0,0,0	0,1,1	1,0,1
0,1,1	–	0,1,1	0,1,1	0,1,1	1,1,1 or 1,1,0 ⁽³⁾

Notes:

1. The lock status is defined by the write protect pin and by DQ1 ('1' for a locked-down block) and DQ0 ('1' for a locked block) as read in the Read Electronic Signature command with DQ1 = V_{IH} and DQ0 = V_{IL} .
2. All blocks are locked at power-up, so the default configuration is 001 or 101 according to \overline{WP} status.
3. A \overline{WP} transition to V_{IH} on a locked block will restore the previous DQ0 value, giving a 111 or 110.

Power-On Reset

To ensure a correct power-up sequence of Platform Flash XL, the V_{DD} ramp time, T_{VDDPOR} , must not be shorter than 200 μ s or longer than 50 ms during power-up (see Figure 18, page 40). These timing limits correspond to the ramp rate values for which the power-up current is in the range where the V_{DD} ramp time is formally characterized or tested.

The device requires that the V_{DD} power supply monotonically rises to the nominal operating voltage within the specified V_{DD} rise time. If the power supply cannot meet this requirement, then the device might not perform power-on reset properly.

During the POR sequence or a reset pulse (\overline{RP}), the $READY_WAIT$ pin is held Low by the device. After the required supply voltages (V_{DD} and V_{DDQ}) have reached

their respective POR thresholds, the $READY_WAIT$ pin is released after a minimum time of t_{RWL} , to give the power supplies an additional margin for them to stabilize before initiating the configuration.

For systems using a slow-rising power supply, an additional power-monitoring circuit can be used to delay the release of the $READY_WAIT$ pin.

If the power drops below the power-down threshold (V_{DDPD}), the device is reset and the $READY_WAIT$ pin is held Low again until the POR threshold is reached (see Figure 18 for an illustration).

The power-up sequences with and without free-running clock are represented in Figure 11, page 31 and Figure 17.

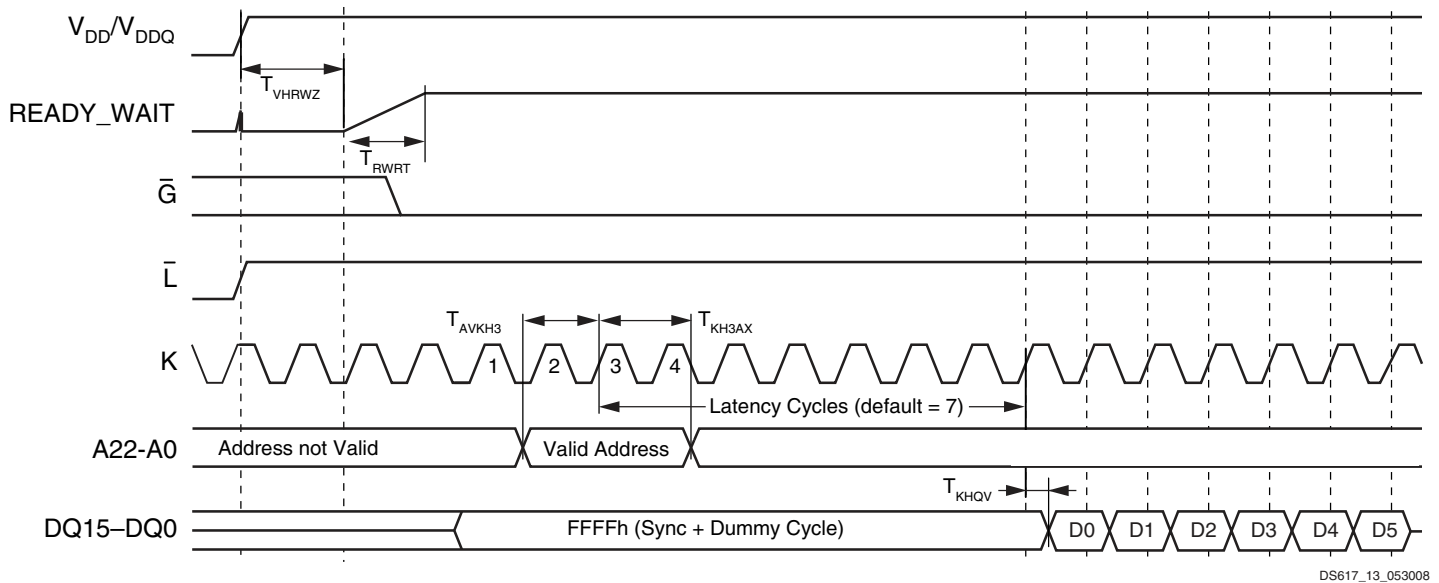

Notes:

- \overline{W} is tied High.

Figure 17: Power-Up Sequence (System with Free-Running Clock)

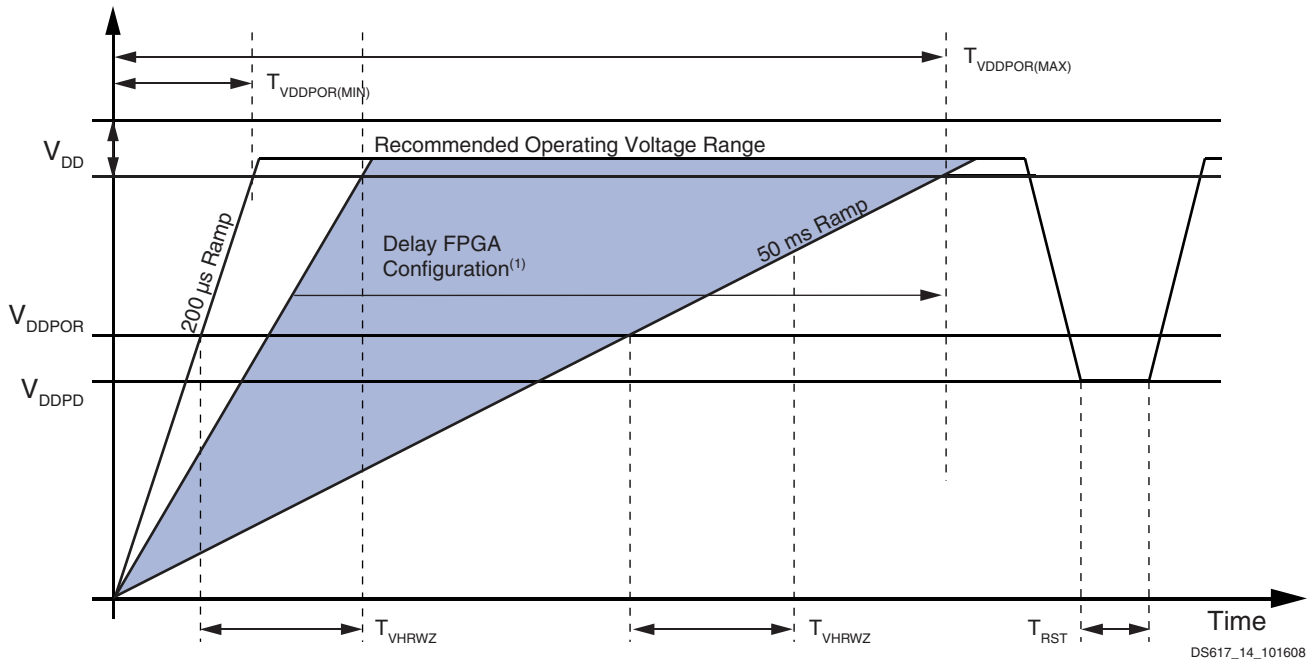

DS617_14_101608

Notes:

1. A slow-ramping V_{DD} power supply can still be below the minimum operating voltage when the READY_WAIT pin is released. In this case, the configuration sequence must be delayed until both V_{DD} and V_{DDQ} have reached their recommended operating conditions.
2. For FPGA configuration via Master-BPI mode, the supplies V_{DD} and V_{DDQ} must reach their respective recommended operating conditions before the start of the FPGA configuration procedure.

Figure 18: V_{DD} Behavior During the Power-Up Sequence or Brownout

First Address Latching Sequence

The first address latching sequence (FALS) is one of the key features of Platform Flash XL. This particular sequence, shown in Figure 19, page 41 and Figure 21, page 43, allows the device to latch the first address soon after V_{IH} is detected on the READY_WAIT pin.

FALS requires four clock cycles. The device internally latches the address from which the system must start to read on the third detected positive edge of the clock after READY_WAIT goes High.

In the case of a system with a free-running clock, FALS takes place in the same way, but it is strongly recommended (see Note 3) to use the timings represented in Figure 12, page 31, Figure 14, page 32, Figure 16, page 33 and Figure 17, page 39.

To start the sequence, the following conditions must be met at the same time:

- \bar{L} must be tied High.

- \overline{RP} must be tied High.
- \bar{G} must be held Low (see Note 2).

FALS is always reset when READY_WAIT is asserted Low, and CR4 is set to 1.

The major advantage of this feature is that it allows the system to start reading data from any available main memory address in the device. If the system cannot guarantee any of the timings, the data output from the device is not guaranteed.

Notes:

1. If V_{DDQ} drops, the output is no longer guaranteed, and it is necessary to reset the device by performing an external reset.
2. Only on power-on-reset, FALS is initiated by READY_WAIT rising (Low-to-High) edge or \bar{G} falling (High-to-Low) edge, whichever occurs last. After POR, FALS is initiated only by a READY_WAIT rising edge.
3. Due to the internal threshold of the READY_WAIT signal, the system might not exactly determine which of the clock edges are the right ones to perform the sequence in the right way.

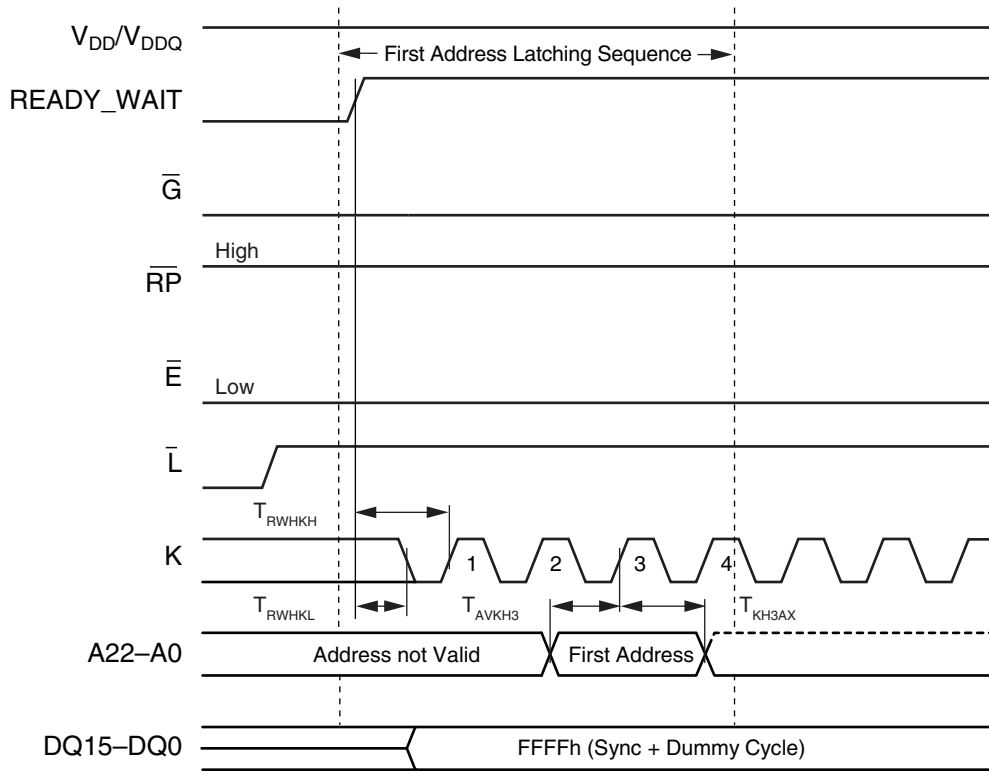

DS617_15_102308

Notes:

1. \bar{W} is tied High.

Figure 19: First Address Latching Sequence (FALS)
Clock is not Free Running and \bar{G} is Held Low

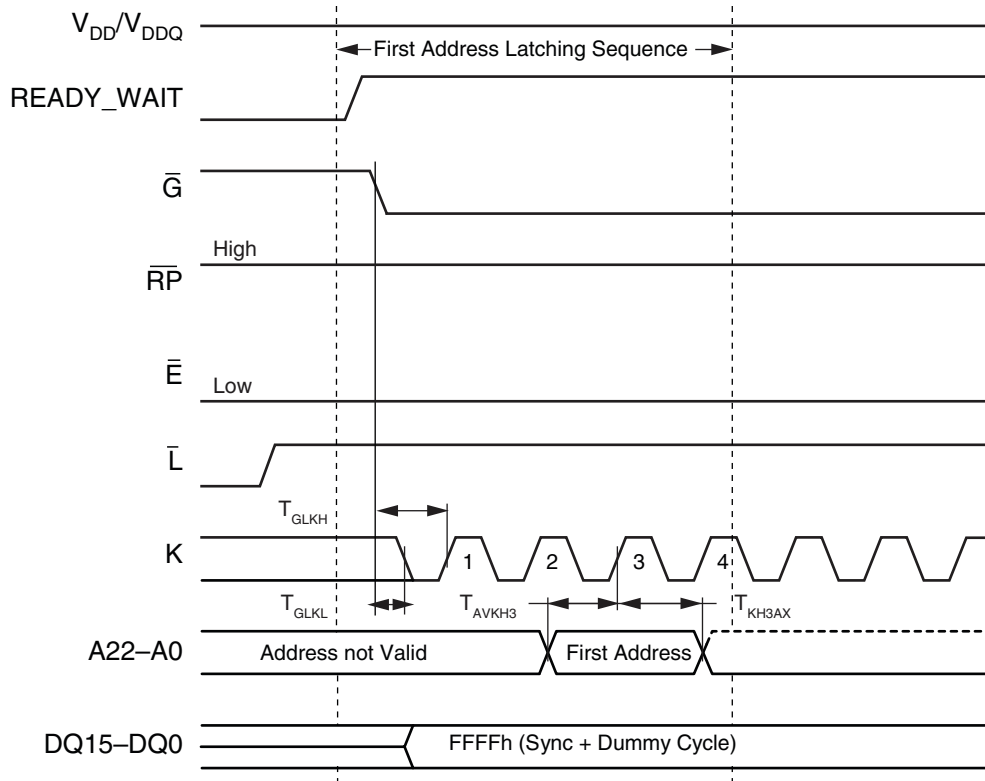

DS617_52_102308

Notes:

1. Only on power-on-reset, FALS is initiated by READY_WAIT rising (Low-to-High) edge or G falling (High-to-Low) edge, whichever occurs last. After POR, FALS is initiated only by a READY_WAIT rising edge.

Figure 20: First Address Latching Sequence (FALS)

Clock is not Free Running and G-bar Transitions High-to-Low after READY_WAIT Goes High

Table 19: FALS Sequence Timings When the Clock Is Not Free Running

Symbol	Parameter		Voltage Range		Unit
			V _{DDQ} = 2.3V to 2.7V	V _{DDQ} = 3.0V to 3.6V	
T _{AVKH3}	Address setup on third positive edge of clock	Min	9	9	ns
T _{KH3AX}	Address hold on third positive edge of clock	Min	9	9	ns
T _{RWHKL}	Clock Low after READY_WAIT High	Min	600	600	ns
T _{RWHKH}	Clock High after READY_WAIT High	Min	600	600	ns
T _{GLKL}	Clock Low after G-bar Low	Min	600	600	ns
T _{GLKH}	Clock High after G-bar Low	Min	600	600	ns

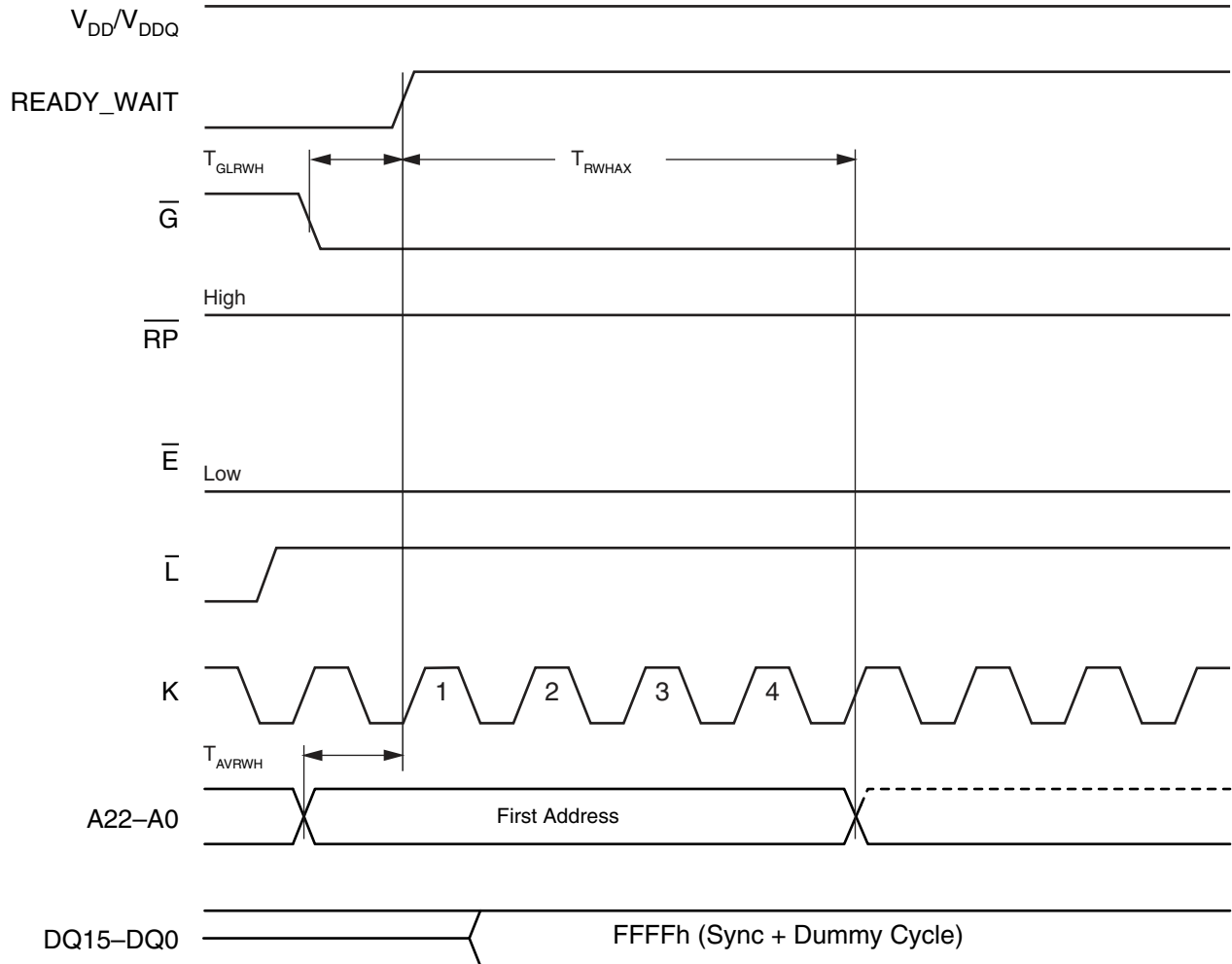

DS617_16_081309

Figure 21: First Address Latching Sequence (FALS): Clock is Free Running

Table 20: FALS Sequence Timings with Free-Running Clock

Symbol	Parameter		Voltage Range		Unit
			$V_{DDQ} = 2.3V \text{ to } 2.7V$	$V_{DDQ} = 3.0V \text{ to } 3.6V$	
T_{AVRWH}	Address Valid before $\overline{READY_WAIT}$ High	Min	200	200	μs
T_{GLRWH}	Output Enable Low before $\overline{READY_WAIT}$ High	Min	200	200	μs
T_{RWHAX}	Address Hold time after $\overline{READY_WAIT}$ High	Min	$4tK + 200^{(1)}$	$4tK + 200^{(1)}$	μs

Notes:

1. $4tK$ = Fourth rising edge of clock (K) after $\overline{READY_WAIT}$ goes High.

Program and Erase Times and Endurance Cycles

Table 21 lists both program and erase times plus the number of program/erase cycles per block. Exact erase times can vary depending on the memory array condition. The best case is when all the bits in the block are at '0' (pre-programmed). The worst case is when all the bits in the block are at '1' (not preprogrammed). Usually, the system overhead is negligible with respect to the erase time. The maximum number of program/erase cycles depends on the V_{PP} voltage supply used.

Table 21: Program/Erase Times and Endurance Cycles^(1,2)

Parameter		Condition		Min	Typ	Typical after 10k P/E Cycles	Max	Unit
$V_{PP} = V_{DDQ}$	Erase	Parameter Block (16 Kword)		–	0.4	1	2.5	s
		Main Block (64 Kword)	Preprogrammed	–	1.2	3	4	s
			Not Preprogrammed	–	1.5	–	4	s
	Program ⁽³⁾	Single Word	Word Program	–	12	–	180	μ s
			Buffer Program	–	12	–	180	μ s
		Buffer (32 words) (Buffer Program)		–	384	–	–	μ s
		Main Block (64 Kword)		–	768	–	–	ms
	Suspend Latency	Program		–	5	–	10	μ s
		Erase		–	5	–	25	μ s
	Program/Erase Cycles (per Block)	Main Blocks		10,000	–	–	–	cycles
Parameter Blocks		10,000	–	–	–	cycles		
$V_{PP} = V_{PPH}$	Erase	Parameter Block (16 Kword)		–	0.4	–	2.5	s
		Main Block (64 Kword)		–	1	–	4	s
	Program ⁽³⁾	Single Word	Word Program	–	10	–	170	μ s
			Buffer Enhanced Factory Program ⁽⁴⁾	–	2.5	–	–	μ s
		Buffer (32 words)	Buffer Program	–	80	–	–	μ s
			Buffer Enhanced Factory Program	–	80	–	–	μ s
		Main Block (64 Kwords)	Buffer Program	–	160	–	–	ms
			Buffer Enhanced Factory Program	–	160	–	–	ms
		Bank (8 Mbits)	Buffer Program	–	1.28	–	–	s
			Buffer Enhanced Factory Program	–	1.28	–	–	s
	Program/Erase Cycles (per Block)	Main Blocks		–	–	–	1000	cycles
		Parameter Blocks		–	–	–	2500	cycles
	Blank Check	Main Blocks		–	16	–	–	ms
Parameter Blocks		–	4	–	–	ms		

Notes:

1. $T_A = -25^\circ\text{C}$ to 85°C ; $V_{DD} = 1.7\text{V}$ to 2V ; $V_{DDQ} = 2.3\text{V}$ to 2.7V or 3.0V to 3.6V .
2. Values are liable to change with the external system-level overhead (command sequence and Status Register polling execution).
3. Excludes the time needed to execute the command sequence.
4. This is an average value on the entire device.

Maximum Rating

Stressing the device above the rating listed in [Table 22](#) might cause permanent damage to the device. These are stress ratings only, and proper operation of the device at these or any other conditions above those indicated in this specification is not implied. Exposure to Absolute Maximum Rating conditions for extended periods can affect device reliability.

Table 22: Absolute Maximum Ratings

Symbol	Parameter	Value		Unit
		Min	Max	
T_A	Ambient operating temperature	-40	85	°C
T_{BIAS}	Temperature under bias	-40	85	°C
T_J	Junction temperature	-	125	°C
T_{STG}	Storage temperature	-65	125	°C
V_{IO}	Input or output voltage	-0.5	4.2	V
V_{DD}	Supply voltage	-0.2	2.5	V
V_{DDQ}	Input/output supply voltage	-0.2	3.8	V
V_{PP}	Program voltage	-0.2	10	V
I_O	Output short circuit current	-	100	mA
T_{VPPH}	Time for V_{PP} at V_{PPH}	-	100	hours

DC and AC Parameters

This section summarizes the operating measurement conditions, and the DC and AC characteristics of the device. The parameters in the DC and AC characteristics tables that follow are derived from tests performed under the measurement conditions summarized in [Table 23](#). Designers should check that the operating conditions in their circuit match the operating conditions when relying on the quoted parameters.

Table 23: Operating and AC Measurement Conditions

Parameter	Min	Max	Units
V_{DD} supply voltage	1.7	2.0	V
V_{DDQ} supply voltage	3.0	3.6	V
	2.3	2.7	V
V_{PP} supply voltage (Factory environment)	8.5	9.5	V
V_{PP} supply voltage (Application environment)	-0.4	$V_{DDQ}+0.4$	V
Ambient operating temperature	-40	85	°C
Load capacitance (C_L)	30		pF
Input rise and fall times	-	5	ns
Input pulse voltages	0 to V_{DDQ}		V
Input and output timing reference voltages	$V_{DDQ}/2$		V

Table 24: Quality and Reliability Characteristics

Symbol	Description	Min	Max	Units
T _{DR}	Data retention	20	–	Years
N _{PE}	Program/erase cycles (Endurance)	10,000 ⁽¹⁾	–	Cycles
V _{ESD}	Electrostatic Discharge (ESD)	2,000	–	Volts

Notes:

1. Program/erase cycles when V_{PP} = V_{DDQ}. See Table 21, page 44 for program/erase cycles when V_{PP} = V_{PPH}.

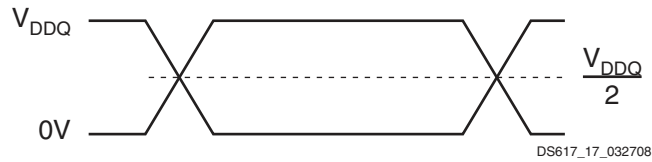
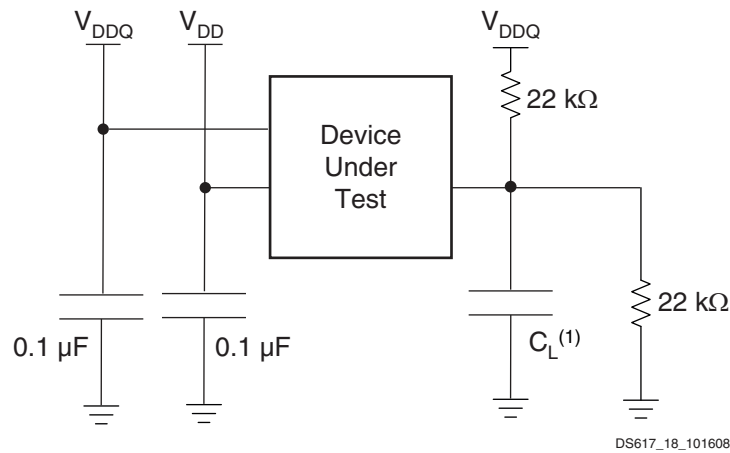

Figure 22: AC Measurement I/O Waveform



Notes:

1. C_L includes JIG capacitance.

Figure 23: AC Measurement Load Circuit

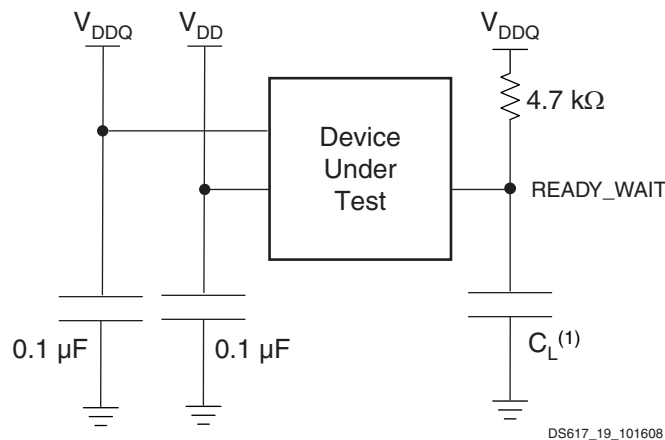

Notes:

1. C_L includes JIG capacitance.

Figure 24: Connecting the READY_WAIT Pin when Using the Device

Table 25: Capacitance⁽¹⁾

Symbol	Parameter	Test condition	Min	Max	Unit
C _{IN}	Input capacitance	V _{IN} = 0V	6	8	pF
C _{OUT}	Output capacitance	V _{OUT} = 0V	8	12	pF

Notes:

1. Sampled only, not 100% tested.

Table 26: DC Characteristics: Currents

Symbol	Parameter	Test Condition	Typ	Max	Unit
I _{LI}	Input leakage current	0V = V _{IN} = V _{DDQ}	–	±1	μA
I _{LO}	Output leakage current	0V = V _{OUT} = V _{DDQ}	–	±1	μA
I _{DD1}	Supply current asynchronous read (F = 5 MHz)	$\bar{E} = V_{IL}, \bar{G} = V_{IH}$	14	16	mA
		4 word	13	17	mA
	Supply current synchronous read (F = 40 MHz)	8 word	15	19	mA
		16 word	17	21	mA
		Continuous	21	26	mA
		Supply current synchronous read (F = 54 MHz)	4 word	16	19
	Supply current synchronous read (F = 54 MHz)	8 word	19	23	mA
		16 word	22	26	mA
Continuous		23	28	mA	
I _{DD2}	Supply current (reset)	$\overline{RP} = V_{SS} \pm 0.2V$	25	75	μA
I _{DD3}	Supply current (standby)	$\bar{E} = V_{DDQ} \pm 0.2V$ K=V _{SS}	25	75	μA
I _{DD4}	Supply current (automatic standby)	$\bar{E} = V_{IL}, G = V_{IH}$	25	75	μA
IDD5 ⁽¹⁾	Supply current (program)	V _{PP} = V _{PPH}	8	20	mA
		V _{PP} = V _{DDQ}	10	25	mA
	Supply current (erase)	V _{PP} = V _{PPH}	8	20	mA
		V _{PP} = V _{DDQ}	10	25	mA
I _{DD6} ^{(1),(2)}	Supply current (dual operations)	Program/Erase in one Bank, Asynchronous Read in another Bank	24	41	mA
		Program/Erase in one Bank, Synchronous Read (Continuous f = 54 MHz) in another Bank	33	53	mA
I _{DD7} ⁽¹⁾	Supply current program/erase suspended (standby)	$\bar{E} = V_{DDQ} \pm 0.2V$ K=V _{SS}	25	75	μA
I _{PP1} ⁽¹⁾	V _{PP} supply current (program)	V _{PP} = V _{PPH}	2	5	mA
		V _{PP} = V _{DDQ}	0.2	5	μA
	V _{PP} supply current (erase)	V _{PP} = V _{PPH}	2	5	mA
		V _{PP} = V _{DDQ}	0.2	5	μA
I _{PP2}	V _{PP} supply current (read)	V _{PP} = V _{DDQ}	0.2	5	μA
I _{PP3} ⁽¹⁾	V _{PP} supply current (standby)	V _{PP} = V _{DDQ}	0.2	5	μA

Notes:

1. Sampled only, not 100% tested.
2. V_{DD} dual operation current is the sum of read and program or erase currents.

Table 27: DC Characteristics: Voltages

Symbol	Parameter	Test condition	Min	Typ	Max	Unit
V_{IL}	Input Low voltage	–	0	–	0.4	V
V_{IH}	Input High voltage	–	$V_{DDQ} - 0.4$	–	$V_{DDQ} + 0.4$	V
V_{OL}	Output Low voltage	$I_{OL} = 100 \mu A$	–	–	0.1	V
V_{OH}	Output High voltage	$I_{OH} = -100 \mu A$	$V_{DDQ} - 0.1$	–	–	V
V_{PP1}	V_{PP} program voltage-logic	Program, Erase	$V_{DDQ} - 0.4$	–	$V_{DDQ} + 0.4$	V
V_{PPH}	V_{PP} program voltage factory	Program, Erase	8.5	9.0	9.5	V
V_{PPLK}	Program or erase lockout	–	–	–	0.4	V
V_{DDPD}	V_{DD} power-down threshold	–	–	–	1.5	V
V_{DDPOR}	V_{DD} power-on reset threshold	–	–	–	1.6	V
V_{DQPOR}	V_{DDQ} power-on reset threshold	–	–	–	1.6	V

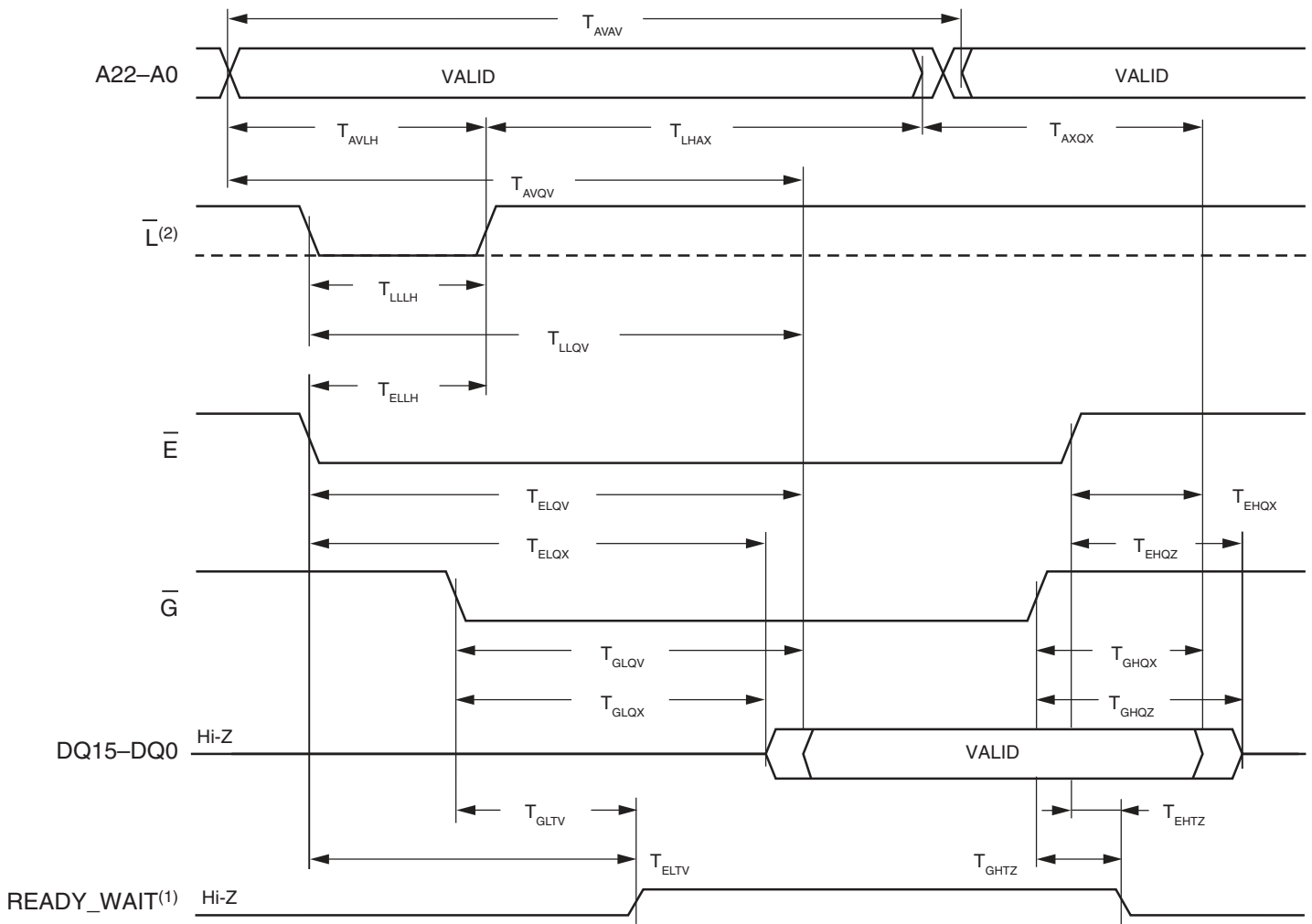

DS617_20_101608

Notes:

1. Write Enable, \bar{W} , is High, READY_WAIT is active Low.
2. Latch Enable, \bar{L} , can be kept Low (also at board level) when the Latch Enable function is not required or supported.

Figure 25: Asynchronous Random Access Read AC Waveforms, CR4 = 0

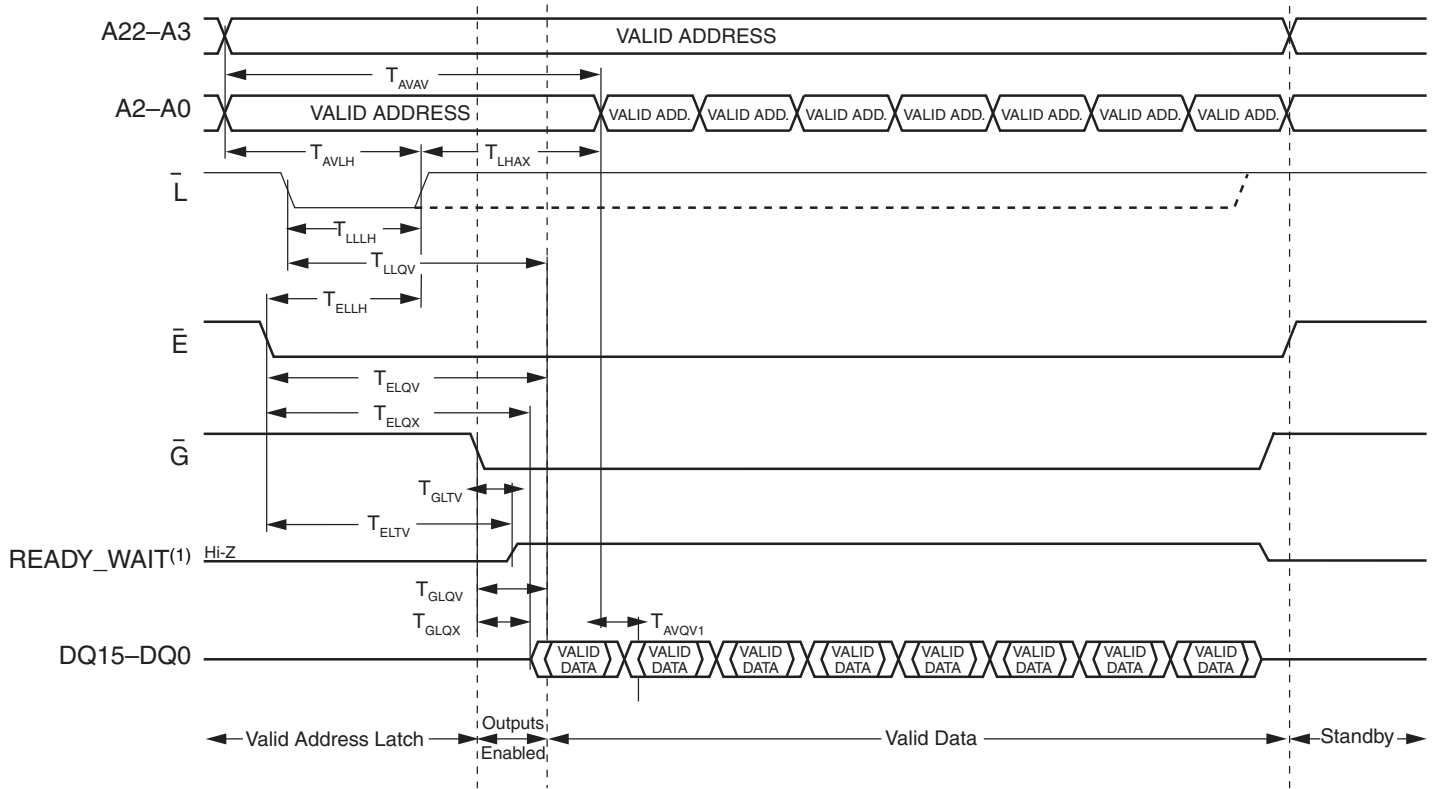

DS617_21_053008

Notes:

1. READY_WAIT is active Low.
2. Write Enable (\bar{W}) is High.

Figure 26: Asynchronous Page Read AC Waveforms, CR4 = 0

Table 28: Asynchronous Read AC Characteristics

Symbol	Alt	Parameter			Voltage Range		Units
					$V_{DDQ} = 2.3V \text{ to } 2.7V$	$V_{DDQ} = 3.0V \text{ to } 3.6V$	
Read Timings	T_{AVAV}	T_{RC}	Address valid to next address valid	Min	85	85	ns
	T_{AVQV}	T_{ACC}	Address valid to output valid (random)	Max	85	85	ns
	T_{AVQV1}	T_{PAGE}	Address valid to output valid (page)	Max	30	30	ns
	$T_{AXQX}^{(1)}$	T_{OH}	Address transition to output transition	Min	0	0	ns
	T_{ELTV}		Chip enable Low to wait valid	Max	17	17	ns
	$T_{ELQV}^{(2)}$	T_{CE}	Chip enable Low to output valid	Max	85	85	ns
	$T_{ELQX}^{(1)}$	T_{LZ}	Chip enable Low to output transition	Min	0	0	ns
	T_{EHTZ}		Chip enable High to wait Hi-Z	Max	17	17	ns
	$T_{EHQX}^{(1)}$	T_{OH}	Chip enable High to output transition	Min	0	0	ns
	$T_{EHQZ}^{(1)}$	T_{HZ}	Chip enable High to output Hi-Z	Max	17	17	ns
	$T_{GLQV}^{(2)}$	T_{OE}	Output enable Low to output valid	Max	25	25	ns
	$T_{GLQX}^{(1)}$	T_{OLZ}	Output enable Low to output transition	Min	0	0	ns
	T_{GLTV}		Output enable Low to wait valid	Max	17	17	ns
	$T_{GHQX}^{(1)}$	T_{OH}	Output enable High to output transition	Min	0	0	ns
	$T_{GHQZ}^{(1)}$	T_{DF}	Output enable High to output Hi-Z	Max	17	17	ns
T_{GHTZ}		Output enable High to wait Hi-Z	Max	17	17	ns	
Latch Timings	T_{AVLH}	T_{AVADVH}	Address valid to latch enable High	Min	10	10	ns
	T_{ELLH}	T_{ELADVH}	Chip enable Low to latch enable High	Min	10	10	ns
	T_{LHAX}	T_{ADVHAX}	Latch enable High to address transition	Min	9	9	ns
	T_{LLLH}	$T_{ADVLADVH}$	Latch enable pulse width	Min	10	10	ns
	T_{LLQV}	T_{ADVLQV}	Latch enable Low to output valid (random)	Max	85	85	ns

Notes:

1. Sampled only, not 100% tested.
2. \bar{G} may be delayed by up to $T_{ELQV} - T_{GLQV}$ after the falling edge of \bar{E} without increasing t_{ELQV} .

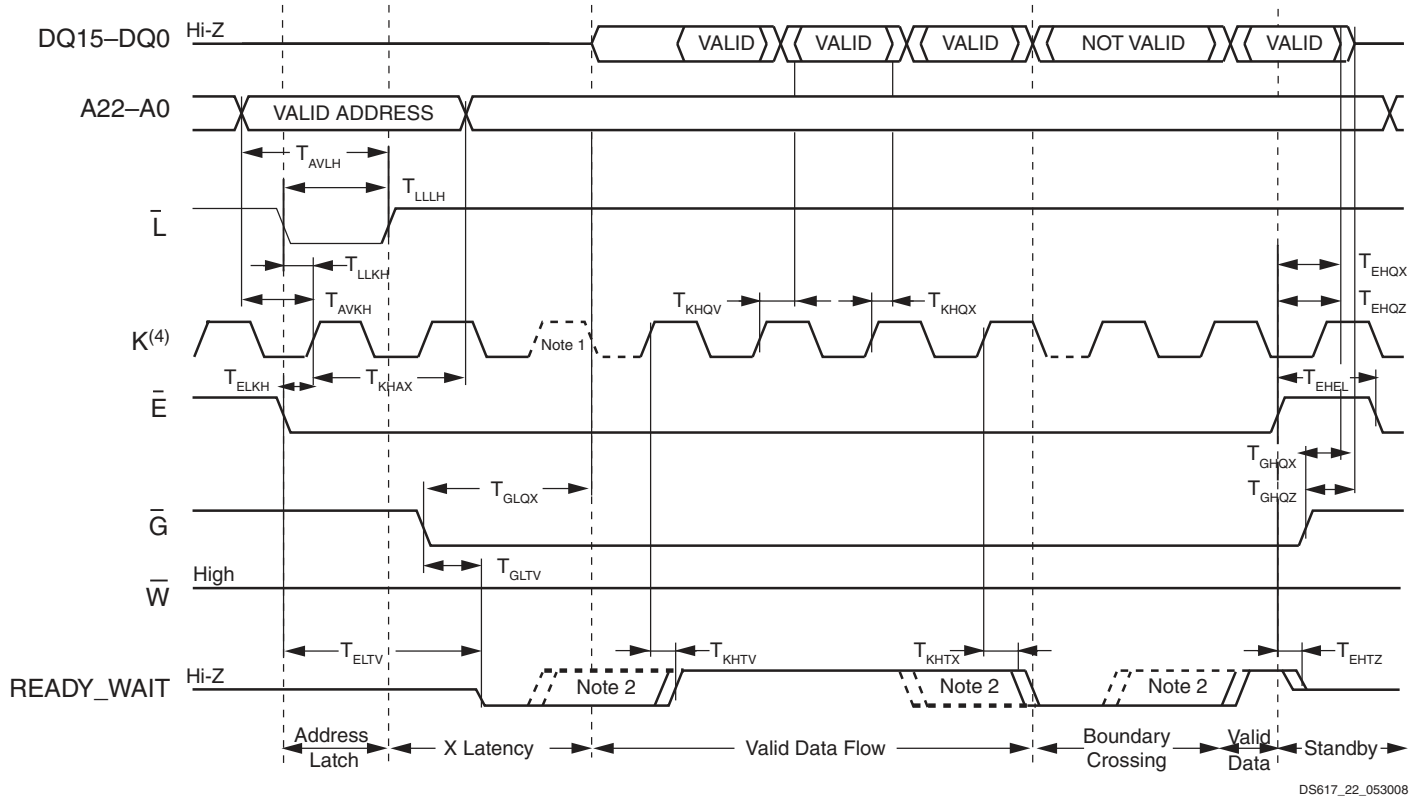

DS617_22_053008

Notes:

1. The number of clock cycles to be inserted depends on the X latency set in the Burst Configuration Register.
2. The READY_WAIT signal can be configured to be active during wait state or one cycle before. READY_WAIT signal is active Low.
3. Address latched and data output on the rising clock edge.
4. Either the rising or the falling edge of the clock signal, K, can be configured as the active edge. Here, the active edge of K is the rising one.
5. The minimum system clock period is T_{KHQV} plus the FPGA data setup time.

Figure 27: Synchronous Burst Read AC Waveforms, CR4 = 0

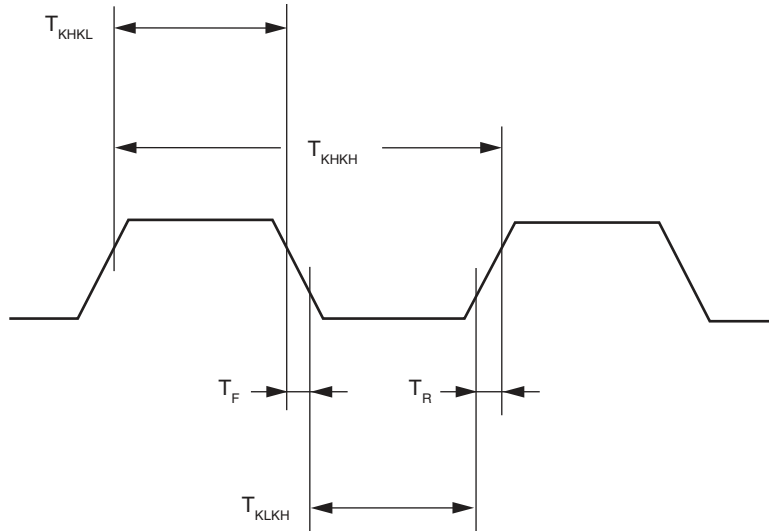

DS617_25_032708

Figure 28: Clock Input AC Waveform

Table 29: Synchronous Read AC Characteristics^(1,2)

Symbol	Alt	Parameter		Voltage Range		Units	
				V _{DDQ} = 2.3V to 2.7V	V _{DDQ} = 3.0V to 3.6V		
Synchronous Read Timings	T _{AVKH}	T _{AVCLKH}	Address Valid to Clock High	Min	9	9	ns
	T _{ELKH}	T _{ELCLKH}	Chip Enable Low to Clock High	Min	9	9	ns
	T _{ELTV} ⁽³⁾		Chip Enable Low to Wait Valid	Max	17	17	ns
	T _{EHEL}		Chip Enable pulse width (subsequent synchronous reads)	Min	20	20	ns
	T _{EHTZ} ⁽³⁾		Chip Enable High to Wait Hi-Z	Max	17	17	ns
	T _{KHAX}	T _{CLKHAX}	Clock High to Address Transition	Min	10	10	ns
	T _{KHQV} ⁽⁴⁾	T _{CLKHQV}	Clock High to Output Valid	Max	16	16	ns
	T _{KHTV} ⁽³⁾		Clock High to WAIT Valid				
	T _{KHQX}	T _{CLKHQX}	Clock High to Output Transition	Min	2	2	ns
	T _{KHTX} ⁽³⁾		Clock High to WAIT Transition				
T _{LLKH}	T _{ADVLCLKH}	Latch Enable Low to Clock High	Min	9	9	ns	
Clock Specifications	T _{KHKH} ⁽⁴⁾	T _{CLK}	Clock Period (f = 54 MHz) ⁽⁴⁾	Min	19	19	ns
	T _{KHKL}		Clock High to Clock Low	Min	6	6	ns
	T _{KLKH}		Clock Low to Clock High				
	T _F		Clock Fall or Rise Time	Max	2	2	ns
	T _R						

Notes:

1. Sampled only, not 100% tested.
2. For other timings, refer to [Table 28, page 50](#).
3. Parameter applies when READY_WAIT is configured (CR4) with the output WAIT function.
4. The minimum system clock period is T_{KHQV} + FPGA data-to-CCLK setup time. See the FPGA data sheet for FPGA setup time.

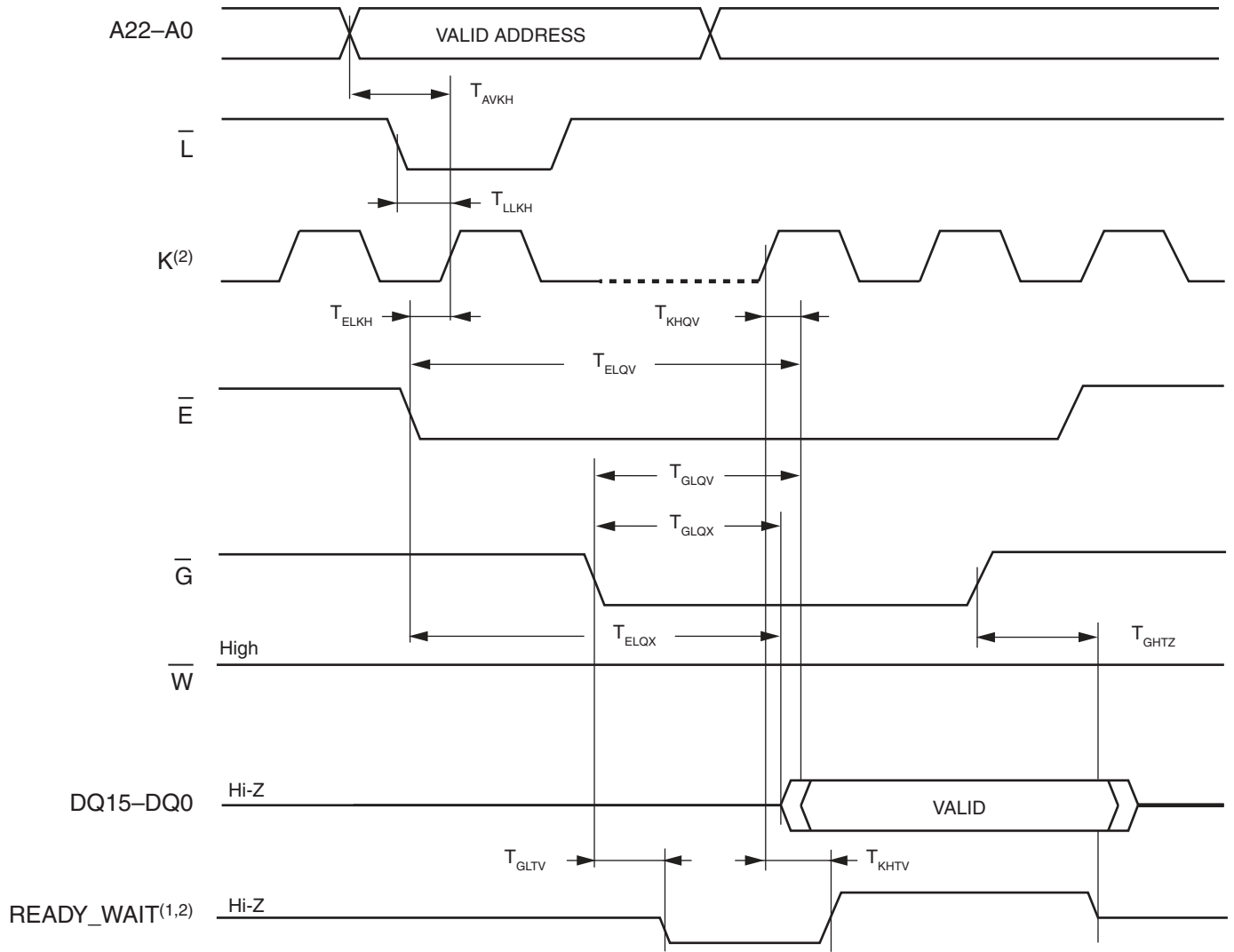

DS617_23_101608

Notes:

1. The READY_WAIT signal is configured to be active during wait state. READY_WAIT signal is active Low.
2. Address latched and data output on the rising clock edge. Either the rising or the falling edge of the clock signal, K, can be configured as the active edge. Here, the active edge is the rising one.
3. The number of clock pulses in the dashed area depends on the latency (default latency = 7). The first clock that occurs while L-bar is Low, latches the address.

Figure 29: Single Synchronous Read AC Waveforms, CR4 = 0

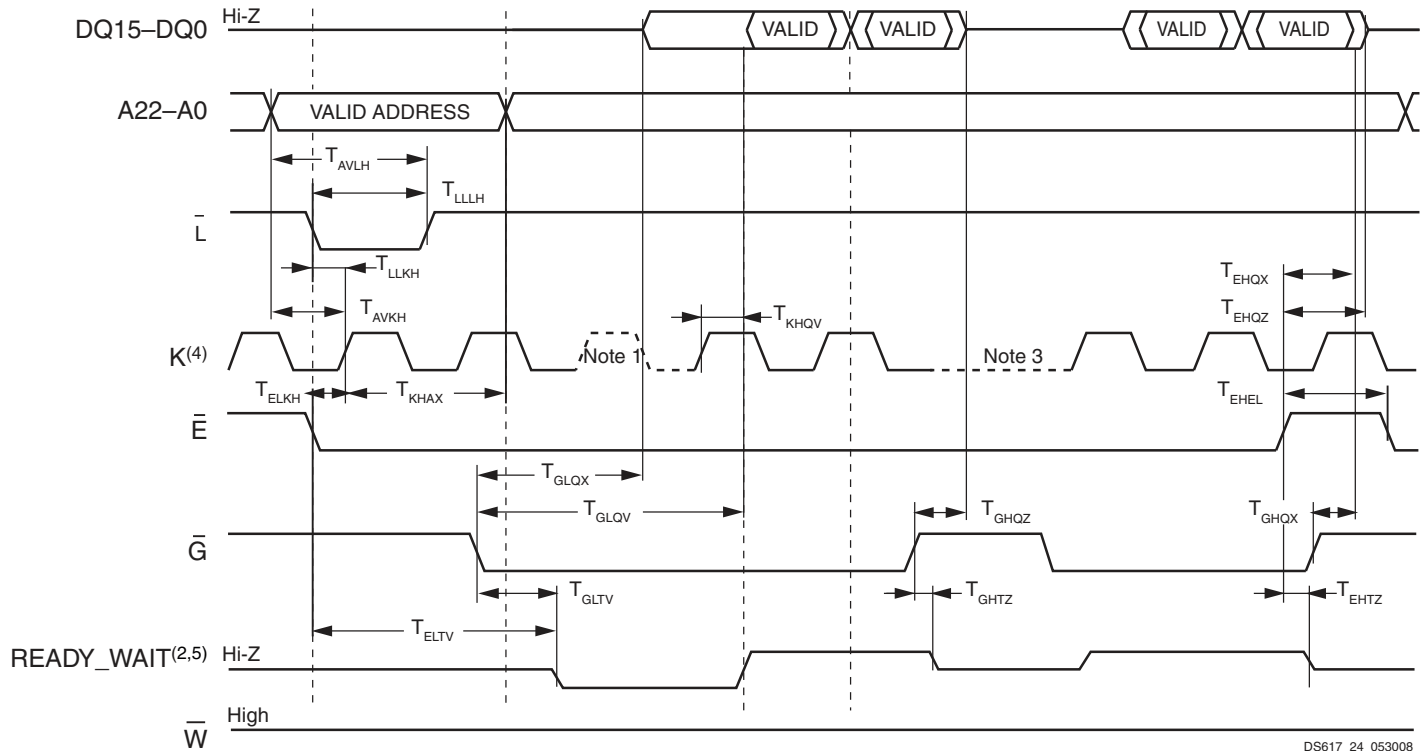

DS617_24_053008

Notes:

1. The number of clock cycles to be inserted depends on the X latency set in the Configuration Register.
2. The READY_WAIT signal is configured to be active during wait state. READY_WAIT signal is active Low.
3. The CLOCK signal can be held High or Low.
4. Address latched and data output on the rising clock edge. Either the rising or the falling edge of the clock signal, K, can be configured as the active edge. Here, the active edge is the rising one.
5. From the moment data is valid, soon after \bar{G} becomes asserted, the READY_WAIT signal reverts its previous level.

Figure 30: Synchronous Burst Read Suspend AC Waveforms, CR4 = 0

Table 30: Write AC Characteristics, Write Enable Controlled⁽¹⁾

Symbol	Alt	Parameter		Voltage Range		Unit	
				V _{DDQ} = 2.3V to 2.7V	V _{DDQ} = 3.0V to 3.6V		
Write Enable Controlled Timings	T _{AVAV}	T _{WC}	Address Valid to Next Address Valid	Min	85	85	ns
	T _{AVLH}		Address Valid to Latch Enable High	Min	10	10	ns
	T _{AVWH} ⁽²⁾		Address Valid to Write Enable High	Min	50	50	ns
	T _{DVWH}	T _{DS}	Data Valid to Write Enable High	Min	50	50	ns
	T _{ELLH}		Chip Enable Low to Latch Enable High	Min	10	10	ns
	T _{ELWL}	T _{CS}	Chip Enable Low to Write Enable Low	Min	0	0	ns
	T _{ELQV}		Chip Enable Low to Output Valid	Min	85	85	ns
	T _{ELKV}		Chip Enable Low to Clock Valid	Min	9	9	ns
	T _{GHWL}		Output Enable High to Write Enable Low	Min	17	17	ns
	T _{LHAX}		Latch Enable High to Address Transition	Min	9	9	ns
	T _{LLLH}		Latch Enable Pulse Width	Min	10	10	ns
	T _{WHAV} ⁽²⁾		Write Enable High to Address Valid	Min	0	0	ns
	T _{WHAX} ⁽²⁾	T _{AH}	Write Enable High to Address Transition	Min	0	0	ns
	T _{WHDX}	T _{DH}	Write Enable High to Input Transition	Min	0	0	ns
	T _{WHEH}	T _{CH}	Write Enable High to Chip Enable High	Min	0	0	ns
	T _{WHEL} ⁽³⁾		Write Enable High to Chip Enable Low	Min	25	25	ns
	T _{WHGL}		Write Enable High to Output Enable Low	Min	0	0	ns
T _{WHLL} ⁽³⁾		Write Enable High to Latch Enable Low	Min	25	25	ns	
T _{WHWL}	T _{WPH}	Write Enable High to Write Enable Low	Min	25	25	ns	
T _{WLWH}	T _{WP}	Write Enable Low to Write Enable High	Min	50	50	ns	
Protection Timings	T _{QVVPL}		Output (Status Register) Valid to V _{PP} Low	Min	0	0	ns
	T _{QVWPL}		Output (Status Register) Valid to Write Protect Low	Min	0	0	ns
	T _{VPHWH}	T _{VPS}	V _{PP} High to Write Enable High	Min	200	200	ns
	T _{WHVPL}		Write Enable High to V _{PP} Low	Min	200	200	ns
	T _{WHWPL}		Write Enable High to Write Protect Low	Min	200	200	ns
	T _{WPHWH}		Write Protect High to Write Enable High	Min	200	200	ns

Notes:

1. Sampled only, not 100% tested.
2. Meaningful only if \bar{L} is always kept Low.
3. T_{WHEL} and T_{WHLL} have this value when reading in the targeted bank or when reading following a Set Configuration Register command. System designers should take this timing into account and can insert a software No-Op instruction to delay the first read in the same bank after issuing any command and to delay the first read to any address after issuing a Set Configuration Register command. If the first read after the command is a Read Array operation in a different bank and no changes to the Configuration Register are issued, T_{WHEL} and T_{WHLL} are 0 ns.

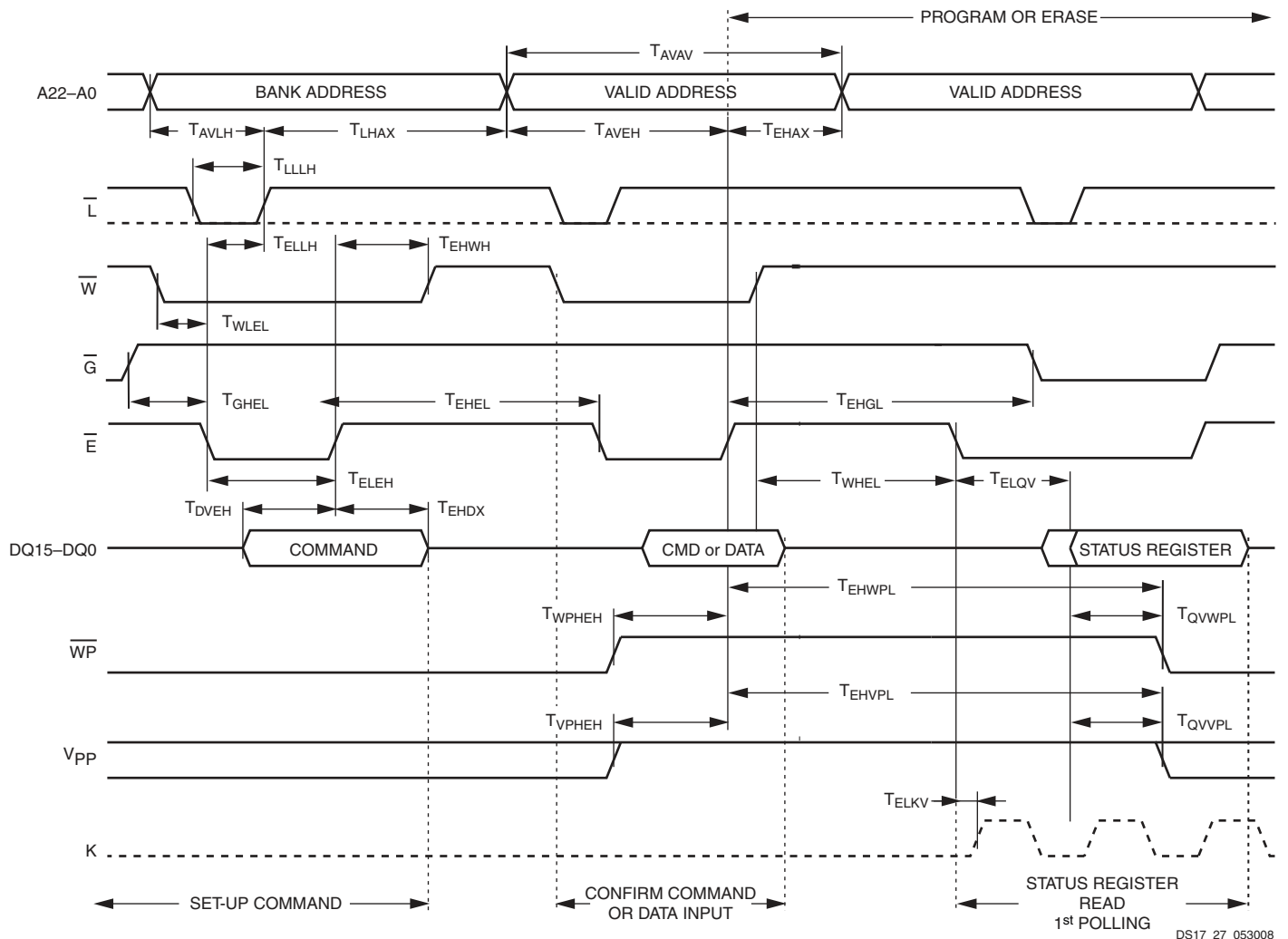

Figure 32: Write AC Waveforms, Chip Enable Controlled

DS17_27_053008

Table 31: Write AC Characteristics, Chip Enable Controlled⁽¹⁾

Symbol	Alt	Parameter		Voltage Range		Unit	
				V _{DDQ} = 2.3V to 2.7V	V _{DDQ} = 3.0V to 3.6V		
Chip Enable Controlled Timings	T _{AVAV}	T _{WC}	Address Valid to Next Address Valid	Min	85	85	ns
	T _{AVEH}		Address Valid to Chip Enable High	Min	50	50	ns
	T _{AVLH}		Address Valid to Latch Enable High	Min	10	10	ns
	T _{DVEH}	T _{DS}	Data Valid to Chip Enable High	Min	50	50	ns
	T _{EHAX}	T _{AH}	Chip Enable High to Address Transition	Min	0	0	ns
	T _{EHDX}	T _{DH}	Chip Enable High to Input Transition	Min	0	0	ns
	T _{EHCL}	T _{CPH}	Chip Enable High to Chip Enable Low	Min	25	25	ns
	T _{EHGL}		Chip Enable High to Output Enable Low	Min	0	0	ns
	T _{EHWH}	T _{CH}	Chip Enable High to Write Enable High	Min	0	0	ns
	T _{ELKV}		Chip Enable Low to Clock Valid	Min	9	9	ns
	T _{ELEH}	T _{CP}	Chip Enable Low to Chip Enable High	Min	50	50	ns
	T _{ELLH}		Chip Enable Low to Latch Enable High	Min	10	10	ns
	T _{ELQV}		Chip Enable Low to Output Valid	Min	85	85	ns
	T _{GHEL}		Output Enable High to Chip Enable Low	Min	17	17	ns
	T _{LHAX}		Latch Enable High to Address Transition	Min	9	9	ns
	T _{LLLH}		Latch Enable Pulse Width	Min	10	10	ns
	Protection Timings	T _{WHEL} ⁽²⁾		Write Enable High to Chip Enable Low	Min	25	25
T _{WLEL}		T _{CS}	Write Enable Low to Chip Enable Low	Min	0	0	ns
T _{EHVPL}			Chip Enable High to V _{PP} Low	Min	200	200	ns
T _{EHWPL}			Chip Enable High to Write Protect Low	Min	200	200	ns
T _{QVVPL}			Output (Status Register) Valid to V _{PP} Low	Min	0	0	ns
T _{QVWPL}			Output (Status Register) Valid to Write Protect Low	Min	0	0	ns
T _{VPHEH}		T _{VPS}	V _{PP} High to Chip Enable High	Min	200	200	ns
T _{WPHEH}		Write Protect High to Chip Enable High	Min	200	200	ns	

Notes:

1. Sampled only, not 100% tested.
2. T_{WHEL} has this value when reading in the targeted bank or when reading following a Set Configuration Register command. System designers should take this timing into account and can insert a software No-Op instruction to delay the first read in the same bank after issuing any command and to delay the first read to any address after issuing a Set Configuration Register command. If the first read after the command is a Read Array operation in a different bank and no changes to the Configuration Register are issued, T_{WHEL} is 0 ns.

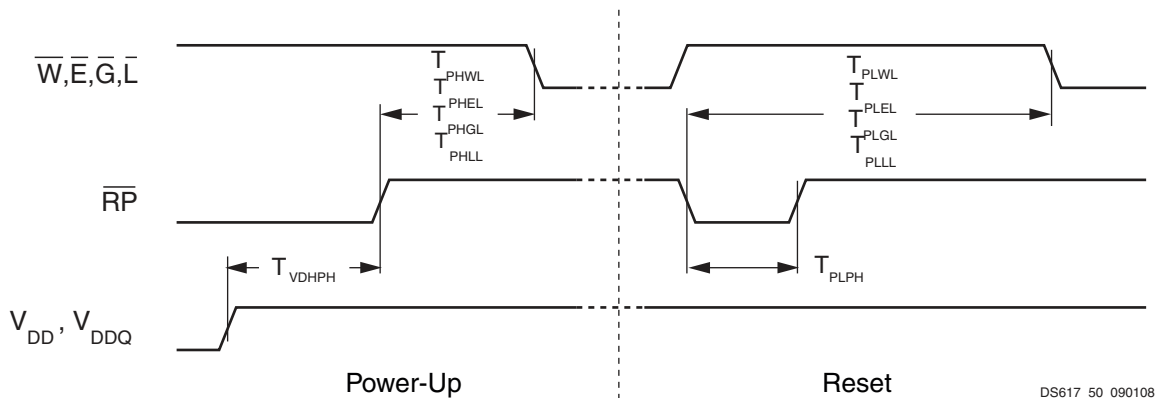

Figure 33: Reset and Power-Up AC Waveforms

DS617_50_090108

Table 32: Reset and Power-Up AC Characteristics

Symbol	Parameter	Test Condition	Min	Unit
T_{PLWL}	Reset Low to: Write Enable Low, Chip Enable Low, Output Enable Low, Latch Enable Low	During Program	60	μs
T_{PLEL}		During Erase	60	μs
T_{PLGL} T_{PLLL}		Other Conditions	60	μs
T_{PHWL} T_{PHEL} T_{PHGL} T_{PHLL}	Reset High to: Write Enable Low Chip Enable Low Output Enable Low Latch Enable Low	—	60	μs
$T_{PLPH}^{(1),(2)}$	RP Pulse Width	—	50	ns
T_{VDHPH}	Supply Voltages High to Reset High	—	0	μs

Notes:

1. A device reset is possible but not guaranteed if $T_{PLPH} < 50$ ns.
2. Sampled only, not 100% tested.

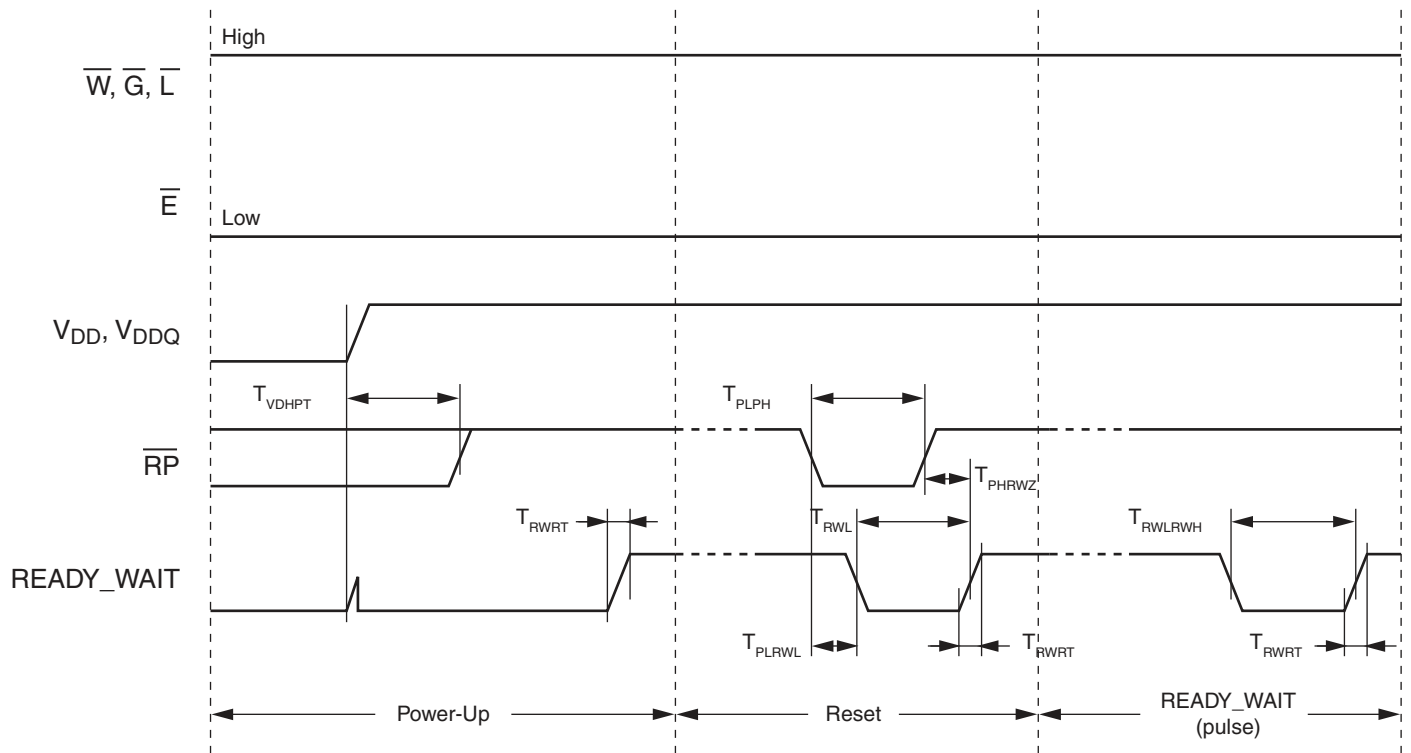

DS617_29_090108

Notes:

1. $READY_WAIT$ requires an external pull-up resistor to V_{DDQ} sufficiently strong to ensure a clean Low-to-High transition within less than T_{RWRT} when the $READY_WAIT$ pin is released to a high-impedance state.

Figure 34: $READY_WAIT$ AC Waveform

Table 33: Power-Up Timing Characteristics

Symbol	Parameter	V _{DDQ} = 2.3V to 2.7V		V _{DDQ} = 3.0V to 3.6V		Unit
		Min	Max	Min	Max	
T _{RWL} ⁽¹⁾	READY_WAIT Low driven from the device	60	–	60	–	μs
T _{RWLRWH}	READY_WAIT pulse driven from the system	50	–	50	–	ns
T _{RWRT} ⁽²⁾	READY_WAIT rise time	–	1	–	1	μs
T _{PHRWZ}	Time from RP High to when device releases READY_WAIT to high-impedance state	–	200	–	200	μs
T _{PLRWL}	Reset Low to READY_WAIT Low	–	50	–	50	ns
T _{RST}	Time required to trigger a device reset when V _{DD} drops below the maximum V _{DDPD} threshold	5	15	5	15	ms
T _{VDDPOR}	V _{DD} ramp rate	0.2	50	0.2	50	ms
T _{VDDQHPOR}	V _{DDQ} ramp rate	0.2	50	0.2	50	ms
T _{VHRWZ}	Time from V _{DD} /V _{DDQ} POR thresholds to when device releases READY_WAIT to high-impedance state	5	15	5	15	ms

Notes:

1. Depends on the V_{DD}/V_{DDQ} operating conditions.
2. READY_WAIT requires an external pull-up resistor to V_{DDQ} sufficiently strong to ensure a clean Low-to-High transition within less than T_{RWRT} when the READY_WAIT pin is released to a high-impedance state.

Ordering Information

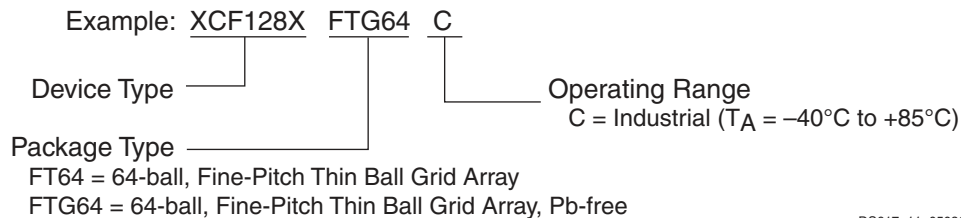

DS617_11_050808

Notes:

1. See the FT64/FTG64 package specifications at http://www.xilinx.com/support/documentation/package_specifications.htm.

Figure 35: Ordering Information

Valid Ordering Combinations

Table 34: Valid Ordering Combinations

XCF128XFTG64C	XCF128XFT64C
---------------	--------------

Marking Information

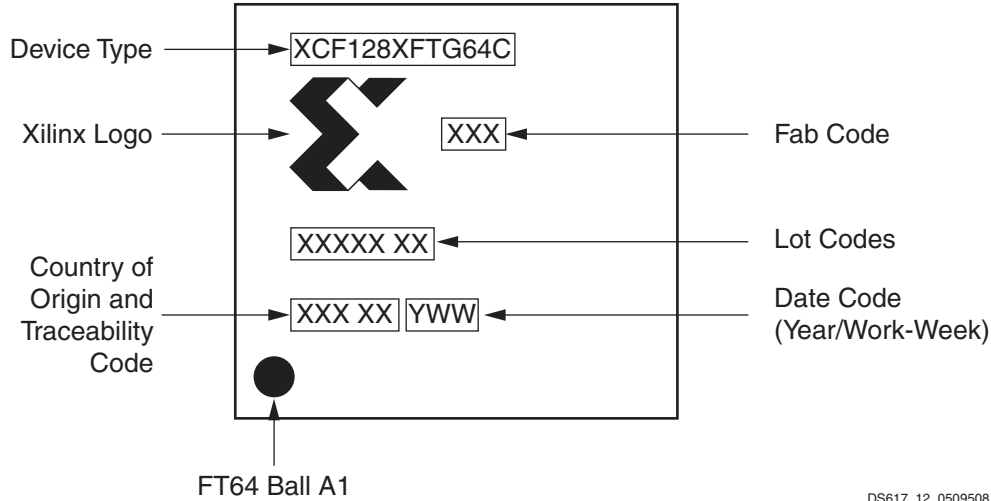

DS617_12_0509508

Figure 36: Marking Information

Appendix A: Block Address Tables

Table 35: Boot Block Addresses

Bank ⁽¹⁾	#	Size (Kword)	Address Range
Parameter Bank	0	16	7FC000-7FFFFFF
	1	16	7F8000-7FBFFF
	2	16	7F4000-7F7FFF
	3	16	7F0000-7F3FFF
	4	64	7E0000-7EFFFF
	5	64	7D0000-7DFFFF
	6	64	7C0000-7CFFFF
	7	64	7B0000-7BFFFF
	8	64	7A0000-7AFFFF
	9	64	790000-79FFFF
	10	64	780000-78FFFF
Bank 1	11	64	770000-77FFFF
	12	64	760000-76FFFF
	13	64	750000-75FFFF
	14	64	740000-74FFFF
	15	64	730000-73FFFF
	16	64	720000-72FFFF
	17	64	710000-71FFFF
	18	64	700000-70FFFF

Table 35: Boot Block Addresses (Cont'd)

Bank ⁽¹⁾	#	Size (Kword)	Address Range
Bank 2	19	64	6F0000-6FFFFF
	20	64	6E0000-6EFFFF
	21	64	6D0000-6DFFFF
	22	64	6C0000-6CFFFF
	23	64	6B0000-6BFFFF
	24	64	6A0000-6AFFFF
	25	64	690000-69FFFF
	26	64	680000-68FFFF
Bank 3	27	64	670000-67FFFF
	28	64	660000-66FFFF
	29	64	650000-65FFFF
	30	64	640000-64FFFF
	31	64	630000-63FFFF
	32	64	620000-62FFFF
	33	64	610000-61FFFF
	34	64	600000-60FFFF
Bank 4	35	64	5F0000-5FFFFF
	36	64	5E0000-5EFFFF
	37	64	5D0000-5DFFFF
	38	64	5C0000-5CFFFF
	39	64	5B0000-5BFFFF
	40	64	5A0000-5AFFFF
	41	64	590000-59FFFF
	42	64	580000-58FFFF
Bank 5	43	64	570000-57FFFF
	44	64	560000-56FFFF
	45	64	550000-55FFFF
	46	64	540000-54FFFF
	47	64	530000-53FFFF
	48	64	520000-52FFFF
	49	64	510000-51FFFF
	50	64	500000-50FFFF
Bank 6	51	64	4F0000-4FFFFF
	52	64	4E0000-4EFFFF
	53	64	4D0000-4DFFFF
	54	64	4C0000-4CFFFF
	55	64	4B0000-4BFFFF
	56	64	4A0000-4AFFFF
	57	64	490000-49FFFF
	58	64	480000-48FFFF

Table 35: Boot Block Addresses (Cont'd)

Bank ⁽¹⁾	#	Size (Kword)	Address Range
Bank 7	59	64	470000-47FFFF
	60	64	460000-46FFFF
	61	64	450000-45FFFF
	62	64	440000-44FFFF
	63	64	430000-43FFFF
	64	64	420000-42FFFF
	65	64	410000-41FFFF
	66	64	400000-40FFFF
Bank 8	67	64	3F0000-3FFFFF
	68	64	3E0000-3EFFFF
	69	64	3D0000-3DFFFF
	70	64	3C0000-3CFFFF
	71	64	3B0000-3BFFFF
	72	64	3A0000-3AFFFF
	73	64	390000-39FFFF
	74	64	380000-38FFFF
Bank 9	75	64	370000-37FFFF
	76	64	360000-36FFFF
	77	64	350000-35FFFF
	78	64	340000-34FFFF
	79	64	330000-33FFFF
	80	64	320000-32FFFF
	81	64	310000-31FFFF
	82	64	300000-30FFFF
Bank 10	83	64	2F0000-2FFFFF
	84	64	2E0000-2EFFFF
	85	64	2D0000-2DFFFF
	86	64	2C0000-2CFFFF
	87	64	2B0000-2BFFFF
	88	64	2A0000-2AFFFF
	89	64	290000-29FFFF
	90	64	280000-28FFFF
Bank 11	91	64	270000-27FFFF
	92	64	260000-26FFFF
	93	64	250000-25FFFF
	94	64	240000-24FFFF
	95	64	230000-23FFFF
	96	64	220000-22FFFF
	97	64	210000-21FFFF
	98	64	200000-20FFFF

Table 35: Boot Block Addresses (Cont'd)

Bank ⁽¹⁾	#	Size (Kword)	Address Range
Bank 12	99	64	1F0000-1FFFFFF
	100	64	1E0000-1EFFFFF
	101	64	1D0000-1DFFFFF
	102	64	1C0000-1CFFFFF
	103	64	1B0000-1BFFFFF
	104	64	1A0000-1AFFFFF
	105	64	190000-19FFFFF
	106	64	180000-18FFFFF
Bank 13	107	64	170000-17FFFFF
	108	64	160000-16FFFFF
	109	64	150000-15FFFFF
	110	64	140000-14FFFFF
	111	64	130000-13FFFFF
	112	64	120000-12FFFFF
	113	64	110000-11FFFFF
	114	64	100000-10FFFFF
Bank 14	115	64	0F0000-0FFFFFF
	116	64	0E0000-0EFFFFF
	117	64	0D0000-0DFFFFF
	118	64	0C0000-0CFFFFF
	119	64	0B0000-0BFFFFF
	120	64	0A0000-0AFFFFF
	121	64	090000-09FFFFF
	122	64	080000-08FFFFF
Bank 15	123	64	070000-07FFFFF
	124	64	060000-06FFFFF
	125	64	050000-05FFFFF
	126	64	040000-04FFFFF
	127	64	030000-03FFFFF
	128	64	020000-02FFFFF
	129	64	010000-01FFFFF
	130	64	000000-00FFFFF

Notes:

1. There are two Bank Regions: Bank Region 1 contains all the banks made up of main blocks only; Bank Region 2 contains the banks made up of the parameter and main blocks (Parameter Bank).

Appendix B: Common Flash Interface

The Common Flash Interface is a JEDEC approved, standardized data structure that can be read from flash memory devices. This interface allows system software to query the device to determine various electrical and timing parameters, density information and functions supported by the memory. The system can interface easily with the device, enabling software to upgrade itself when necessary.

When the Read CFI Query Command is issued, the device enters CFI Query mode and the data structure is read from

the memory. [Table 36](#), through and [Table 45, page 70](#) show the addresses used to retrieve the data. The Query data is always presented on the lowest order data outputs (DQ7–DQ0), the other outputs (DQ15–DQ8) are set to ‘0’.

The CFI data structure also contains a security area where a unique 64-bit security number is written ([Figure 8, page 22](#)). The security number cannot be changed and can only be accessed in Read mode. Read Array command is used to return to Read mode.

Table 36: Query Structure Overview

Offset	Subsection Name	Description
000h	Reserved	Reserved for algorithm-specific information
010h	CFI Query Identification String	Command set ID and algorithm data offset
01Bh	System Interface Information	Device timing & voltage information
027h	Device Geometry Definition	Flash device layout
P	Primary Algorithm-specific Extended Query table	Additional information specific to the Primary Algorithm (optional)
A	Alternate Algorithm-specific Extended Query table	Additional information specific to the Alternate Algorithm (optional)
080h	Security Code Area	Lock Protection Register Unique device Number and User Programmable OTP

Notes:

- The flash memory displays the CFI data structure when CFI Query command is issued. This table lists the main sub-sections detailed in [Table 38, page 66](#), and [Table 41, page 68](#). Query data is always presented on the lowest order data outputs.

Table 37: CFI Query Identification String

Offset	Description	Value
000h	Manufacturer code	0049h
001h	Device code	506Bh
002h-00Fh	Reserved	Reserved
010h 011h 012h	Query Unique ASCII String "QRY"	0051h ("Q") 0052h ("R") 0059h ("Y")
013h 014h	Primary Algorithm Command Set and Control Interface ID code 16 bit ID code defining a specific algorithm	0001h 0000h
015h 016h	Address for Primary Algorithm extended Query table (see Table 40, page 67)	Offset = P = 000Ah 0001h
017h 018h	Alternate Vendor Command Set and Control Interface ID Code second vendor (specified algorithm supported)	0000h 0000h
019h 01Ah	Address for Alternate Algorithm extended Query table	Value = A = 0000h 0000h

Table 38: CFI Query System Interface Information

Offset	Data	Description	Value
01Bh	0017h	V _{DD} Logic Supply Minimum Program/Erase or Write voltage bit 7 to 4 BCD value in volts bit 3 to 0 BCD value in 100 millivolts	1.7V
01Ch	0020h	V _{DD} Logic Supply Maximum Program/Erase or Write voltage bit 7 to 4 BCD value in volts bit 3 to 0 BCD value in 100 millivolts	2V
01Dh	0085h	V _{PP} [Programming] Supply Minimum Program/Erase voltage bit 7 to 4 HEX value in volts bit 3 to 0 BCD value in 100 millivolts	8.5V
01Eh	0095h	V _{PP} [Programming] Supply Maximum Program/Erase voltage bit 7 to 4 HEX value in volts bit 3 to 0 BCD value in 100 millivolts	9.5V
01Fh	0004h	Typical time-out per single byte/word program = 2 ⁿ μs	16 μs
020h	0009h	Typical time-out for Buffer Program = 2 ⁿ μs	512 μs
021h	000Ah	Typical time-out per individual block erase = 2 ⁿ ms	1s
022h	0000h	Typical time-out for full chip erase = 2 ⁿ ms	–
023h	0004h	Maximum time-out for word program = 2 ⁿ times typical	256 μs
024h	0004h	Maximum time-out for Buffer Program = 2 ⁿ times typical	8192 μs
025h	0002h	Maximum time-out per individual block erase = 2 ⁿ times typical	4s
026h	0000h	Maximum time-out for chip erase = 2 ⁿ times typical	–

Table 39: Device Geometry Definition

Offset	Data	Description	Value
027h	0018h	Device Size = 2 ⁿ in number of bytes	16 Mbytes
028h 029h	0001h 0001h	Flash Device Interface Code description	x16 Sync.
02Ah 02Bh	0006h 0000h	Maximum number of bytes in multi-byte program or page = 2 ⁿ	64 bytes
02Ch	0002h	Number of identical sized erase block regions within the device bit 7 to 0 = x = number of Erase Block Regions	2
02Dh 02Eh	007Eh 0000h	Erase Block Region 1 Information Number of identical-size erase blocks = 007Eh + 1	127
02Fh 030h	0000h 0002h	Erase Block Region 1 Information Block size in Region 1 = 0200h × 256 byte	128 Kbyte
031h 032h	0003h 0000h	Erase Block Region 2 Information Number of identical-size erase blocks = 0003h + 1	4
033h 034h	0080h 0000h	Erase Block Region 2 Information Block size in Region 2 = 0080h × 256 byte	32 Kbyte
035h 038h	Reserved	Reserved for future erase block region information	–

Table 40: Primary Algorithm-Specific Extended Query Table

Offset	Data	Description	Value
(P)h = 10Ah	0050h 0052h 0049h	Primary Algorithm extended Query table unique ASCII string "PRI"	"P" R" I"
(P+3)h = 10Dh	0031h	Major version number, ASCII	"1"
(P+4)h = 10Eh	0033h	Minor version number, ASCII	"3"
(P+5)h = 10Fh	00E6h 0003h	Extended Query table contents for Primary Algorithm. Address (P+5)h contains less significant byte: bit 0 Chip Erase supported (1 = Yes, 0 = No) bit 1 Erase Suspend supported (1 = Yes, 0 = No) bit 2 Program Suspend supported (1 = Yes, 0 = No) bit 3 Legacy Lock/Unlock supported (1 = Yes, 0 = No) bit 4 Queued Erase supported (1 = Yes, 0 = No) \ bit 5 Instant individual block locking supported (1 = Yes, 0 = No) bit 6 Protection bits supported (1 = Yes, 0 = No) bit 7 Page mode read supported (1 = Yes, 0 = No) bit 8 Synchronous read supported (1 = Yes, 0 = No) bit 9 Simultaneous operation supported (1 = Yes, 0 = No) bit 10 to 31 Reserved; undefined bits are '0'. If bit 31 is '1' then another 31 bit field of optional features follows at the end of the bit-30 field.	No Yes Yes No No Yes Yes Yes Yes Yes
(P+7)h = 111h	0000h		
(P+8)h = 112h	0000h		
(P+9)h = 113h	0001h	Supported Functions after Suspend Read Array, Read Status Register and CFI Query: bit 0 Program supported after Erase Suspend (1 = Yes, 0 = No) bit 7 to 1 Reserved; undefined bits are '0'	Yes
(P+A)h = 114h	0003h	Block Protect Status Defines which bits in the Block Status Register section of the Query are implemented: bit 0 Block protect Status Register Lock/Unlock bit active (1 = Yes, 0 = No) bit 1 Block Lock Status Register Lock-Down bit active (1 = Yes, 0 = No) bit 15 to 2; Reserved for future use undefined bits are '0'	Yes Yes
(P+B)h = 115h	0000h		
(P+C)h = 116h	0018h	V _{DD} Logic Supply Optimum Program/Erase voltage (highest performance): bit 7 to 4 HEX value in volts bit 3 to 0 BCD value in 100 mV	1.8V
(P+D)h = 117h	0090h	V _{PP} Supply Optimum Program/Erase voltage: bit 7 to 4 HEX value in volts bit 3 to 0 BCD value in 100 mV	9V

Table 41: Protection Register Information

Offset	Data	Description	Value
(P+E)h = 118h	0002h	Number of protection register fields in JEDEC ID space. 0000h indicates that 256 fields are available.	2
(P+F)h = 119h	0080h	Protection Register 1: Protection Description: Bits 0-7 Lower byte of protection register address Bits 8-15 Upper byte of protection register address Bits 16-23 2 ⁿ bytes in factory pre-programmed region Bits 24-31 2 ⁿ bytes in user programmable region	80h
(P+10)h = 11Ah	0000h		00h
(P+ 11)h = 11Bh	0003h		8 bytes
(P+12)h = 11Ch	0003h		8 bytes
(P+13)h = 11Dh	0089h		89h
(P+14)h = 11Eh	0000h	Protection Register 2: Protection Description: Bits 0-31 protection register address Bits 32-39 ⁿ number of factory programmed regions (lower byte) Bits 40-47 ⁿ number of factory programmed regions (upper byte) Bits 48-55 2 ⁿ bytes in factory programmable region Bits 56-63 ⁿ number of user programmable regions (lower byte) Bits 64-71 ⁿ number of user programmable regions (upper byte) Bits 72-79 2 ⁿ bytes in user programmable region	00h
(P+15)h = 11Fh	0000h		00h
(P+16)h = 120h	0000h		00h
(P+17)h = 121h	0000h		0
(P+18)h = 122h	0000h		0
(P+19)h = 123h	0000h		0
(P+1A)h = 124h	0010h		16
(P+1B)h = 125h	0000h		0
(P+1C)h = 126h	0004h		16

Table 42: Burst Read Information

Offset	Data	Description	Value
(P+1D)h = 127h	0003h	Page-mode read capability bits 0-7 n' such that 2 ⁿ HEX value represents the number of read-page bytes. See offset 0028h for device word width to determine page-mode data output width.	8 bytes
(P+1E)h = 128h	0004h	Number of synchronous mode read configuration fields that follow.	4
(P+1F)h = 129h	0001h	Synchronous mode read capability configuration 1 bit 3-7 Reserved bit 0-2 n' such that 2 ⁿ⁺¹ HEX value represents the maximum number of continuous synchronous reads when the device is configured for its maximum word width. A value of 07h indicates that the device is capable of continuous linear bursts that output data until the internal burst counter reaches the end of the device's burstable address space. This field's 3-bit value can be written directly to the read configuration register bit 0-2 if the device is configured for its maximum word width. See offset 0028h for word width to determine the burst data output width.	4
(P+20)h = 12Ah	0002h	Synchronous mode read capability configuration 2	8
(P-21)h = 12Bh	0003h	Synchronous mode read capability configuration 3	16
(P+22)h = 12Ch	0007h	Synchronous mode read capability configuration 4	Cont.

Table 43: Bank and Erase Block Region Information^(1,2)

Offset	Data	Description
(P+23)h = 12Dh	02h	Number of Bank Regions within the device

Notes:

1. The variable P is a pointer which is defined at CFI offset 015h.
2. Bank Regions. There are two Bank Regions, see [Table 35, page 61](#).

Table 44: Bank and Erase Block Region 1 Information^(1,2)

Offset	Data	Description
(P+24)h = 12Eh	0Fh	Number of identical banks within Bank Region 1
(P+25)h = 12Fh	00h	
(P+26)h = 130h	11h	Number of program or erase operations allowed in Bank Region 1: Bits 0–3: Number of simultaneous program operations Bits 4–7: Number of simultaneous erase operations
(P+27)h = 131h	00h	Number of program or erase operations allowed in other banks while a bank in same region is programming Bits 0–3: Number of simultaneous program operations Bits 4–7: Number of simultaneous erase operations
(P+28)h = 132h	00h	Number of program or erase operations allowed in other banks while a bank in this region is erasing Bits 0–3: Number of simultaneous program operations Bits 4–7: Number of simultaneous erase operations
(P+29)h = 133h	01h	Types of erase block regions in Bank Region 1 n = number of erase block regions with contiguous same-sized erase blocks. Symmetrically blocked banks have one blocking region ⁽²⁾ .
(P+2A)h = 134h	07h	Bank Region 1 Erase Block Type 1 Information: Bits 0–15: n+1 = number of identical-sized erase blocks Bits 16–31: n×256 = number of bytes in erase block region
(P+2B)h = 135h	00h	
(P+2C)h = 136h	00h	
(P+2D)h = 137h	02h	
(P+2E)h = 138h	64h	Bank Region 1 (Erase Block Type 1)
(P+2F)h = 139h	00h	Minimum block erase cycles × 1000
(P+30)h = 13Ah	01h	Bank Region 1 (Erase Block Type 1): Blts per cell, internal ECC Bits 0–3: bits per cell in erase region Bit 4: reserved for “internal ECC used” Bits 5–7: reserved
(P+31)h = 13Bh	03h	Bank Region 1 (Erase Block Type 1): Page mode and Synchronous mode capabilities Bit 0: Page-mode reads permitted Bit 1: Synchronous reads permitted Bit 2: Synchronous writes permitted Bits 3–7: reserved
–	–	Bank Region 1 Erase Block Type 2 Information Bits 0–15: n+1 = number of identical-sized erase blocks Bits 16–31: n×256 = number of bytes in erase block region
		Bank Region 1 (Erase Block Type 2) Minimum block erase cycles × 1000
		Bank Regions 1 (Erase Block Type 2): Bits per cell, internal ECC Bits 0–3: bits per cell in erase region Bit 4: reserved for “internal ECC used” Bits 5–7: reserved
		Bank Region 1 (Erase Block Type 2): Page mode and Synchronous mode capabilities Bit 0: Page-mode reads permitted Bit 1: Synchronous reads permitted Bit 2: Synchronous writes permitted Bits 3–7: reserved

Notes:

1. The variable P is a pointer which is defined at CFI offset 015h.
2. Bank Regions. There are two Bank Regions, see [Table 35, page 61](#).

Table 45: Bank and Erase Block Region 2 Information^(1,2)

Offset	Data	Description
(P+32)h = 13Ch	01h	Number of identical banks within Bank Region 2
(P+33)h = 13Dh	00h	
(P+34)h = 13Eh	11h	Number of program or erase operations allowed in Bank Region 2: Bits 0–3: Number of simultaneous program operations Bits 4–7: Number of simultaneous erase operations
(P+35)h = 13Fh	00h	Number of program or erase operations allowed in other banks while a bank in this region is programming Bits 0–3: Number of simultaneous program operations Bits 4–7: Number of simultaneous erase operations
(P+36)h = 140h	00h	Number of program or erase operations allowed in other banks while a bank in this region is erasing Bits 0–3: Number of simultaneous program operations Bits 4–7: Number of simultaneous erase operations
(P+37)h = 141h	02h	Types of erase block regions in Bank Region 2 n = number of erase block regions with contiguous same-sized erase blocks. Symmetrically blocked banks have one blocking region. ⁽²⁾
(P+38)h = 142h	06h	Bank Region 2 Erase Block Type 1 Information Bits 0–15: n+1 = number of identical-sized erase blocks Bits 16–31: n×256 = number of bytes in erase block region
(P+39)h = 143h	00h	
(P+3A)h = 144h	00h	
(P+3B)h = 145h	02h	
(P+3C)h = 146h	64h	Bank Region 2 (Erase Block Type 1)
(P+3D)h = 147h	00h	Minimum block erase cycles × 1000
(P+3E)h = 148h	01h	Bank Region 2 (Erase Block Type 1): Bits per cell, internal ECC Bits 0–3: bits per cell in erase region Bit 4: reserved for “internal ECC used” Bits 5–7: reserved
(P+3F)h = 149h	03h	Bank Region 2 (Erase Block Type 1): Page mode and Synchronous mode capabilities (defined in Table 42, page 68) Bit 0: Page-mode reads permitted Bit 1: Synchronous reads permitted Bit 2: Synchronous writes permitted Bits 3–7: reserved
(P+40)h = 14Ah	03h	Bank Region 2 Erase Block Type 2 Information Bits 0–15: n+1 = number of identical-sized erase blocks Bits 16–31: n×256 = number of bytes in erase block region
(P+41)h = 14Bh	00h	
(P+42)h = 14Ch	80h	
(P+43)h = 14Dh	00h	
(P+44)h = 14Eh	64h	Bank Region 2 (Erase Block Type 2)
(P+45)h = 14Fh	00h	Minimum block erase cycles × 1000
(P+46)h = 150h	01h	Bank Region 2 (Erase Block Type 2): Bits per cell, internal ECC Bits 0–3: bits per cell in erase region Bit 4: reserved for “internal ECC used” Bits 5–7: reserved
(P+47)h = 151h	03h	Bank Region 2 (Erase Block Type 2): Page mode and Synchronous mode capabilities (defined in Table 42, page 68) Bit 0: Page-mode reads permitted Bit 1: Synchronous reads permitted Bit 2: Synchronous writes permitted Bits 3–7: reserved
(P+48)h = 152h	–	Feature Space definitions
(P+49)h = 153h	–	Reserved

Notes:

1. The variable P is a pointer which is defined at CFI offset 015h.
2. Bank Regions. There are two Bank Regions, see [Table 35, page 61](#).

Appendix C: Flowcharts and Pseudocodes

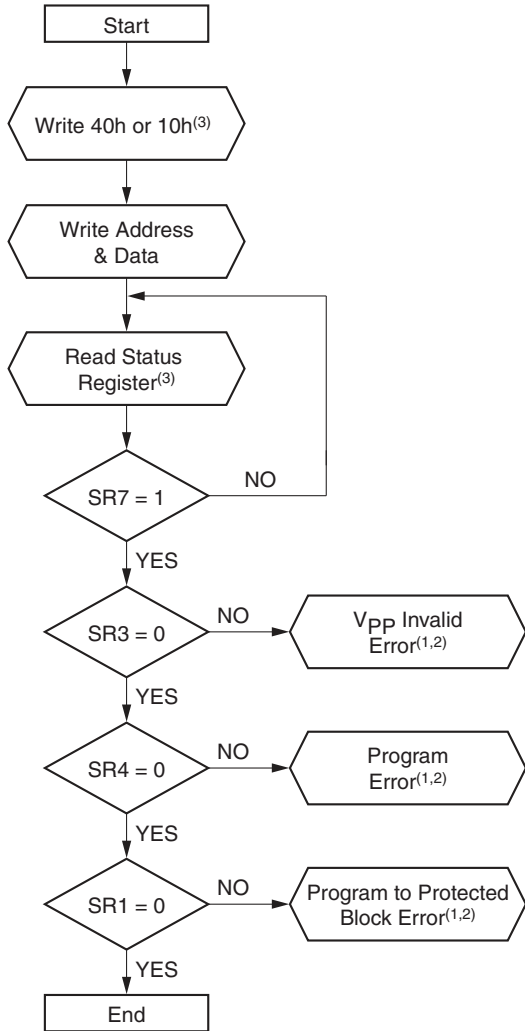

```

program_command (addressToProgram, dataToProgram) {
    writeToFlash (addressToProgram, 0x40);
    /*writeToFlash (addressToProgram, 0x10);*/
    /*see note (3)*/

    writeToFlash (addressToProgram, dataToProgram) ;
    /*Memory enters read status state after
    the Program Command*/

    do {
        status_register=readFlash (addressToProgram);
        /*see note (3)*/
        /* E or G must be toggled*/

    } while (status_register.SR7== 0) ;

    if (status_register.SR3==1) /*VPP invalid error */
        error_handler ( ) ;

    if (status_register.SR4==1) /*program error */
        error_handler ( ) ;

    if (status_register.SR1==1) /*program to protect block error */
        error_handler ( ) ;

}
  
```

DS617_31_101608

Notes:

1. Status check of SR1 (Protected Block), SR3 (VPP Invalid) and SR4 (Program Error) can be made after each program operation or after a sequence.
2. If an error is found, the Status Register must be cleared before further Program/Erase Controller operations.
3. Any address within the bank can equally be used.
4. To read the memory in Asynchronous mode, the CR15 Configuration Register bit must be written to 1.

Figure 37: Program Flowchart and Pseudocode

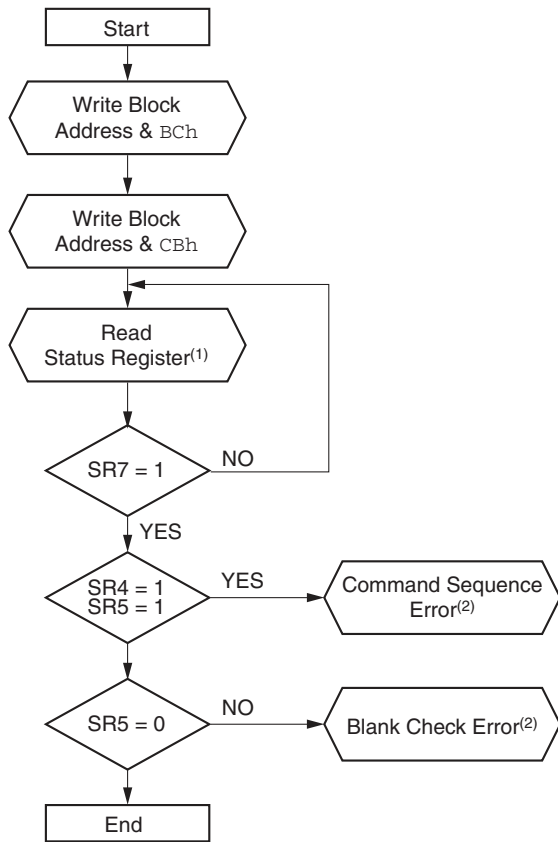

```

blank_check_command (blockToCheck) {
    writeToFlash (blockToCheck, 0xBC);

    writeToFlash (blockToCheck, 0xCB);
    /* Memory enters read status state after
    the Blank Check Command */

    do {
        status_register = readFlash (blockToCheck);
        /* see note (1) */
        /* E or G must be toggled */
    } while (status_register.SR7==0);

    if (status_register.SR4==1) && (status_register.SR5==1)
    /* command sequence error */
        error_handler ();

    if (status_register.SR5==1)
    /* Blank Check error */
        error_handler ();
}
  
```

DS617_32_101608

Notes:

1. Any address within the bank can equally be used.
2. If an error is found, the Status Register must be cleared before further Program/Erase operations.
3. To read the memory in Asynchronous mode, the CR15 Configuration Register bit must be written to 1.

Figure 38: Blank Check Flowchart and Pseudocode

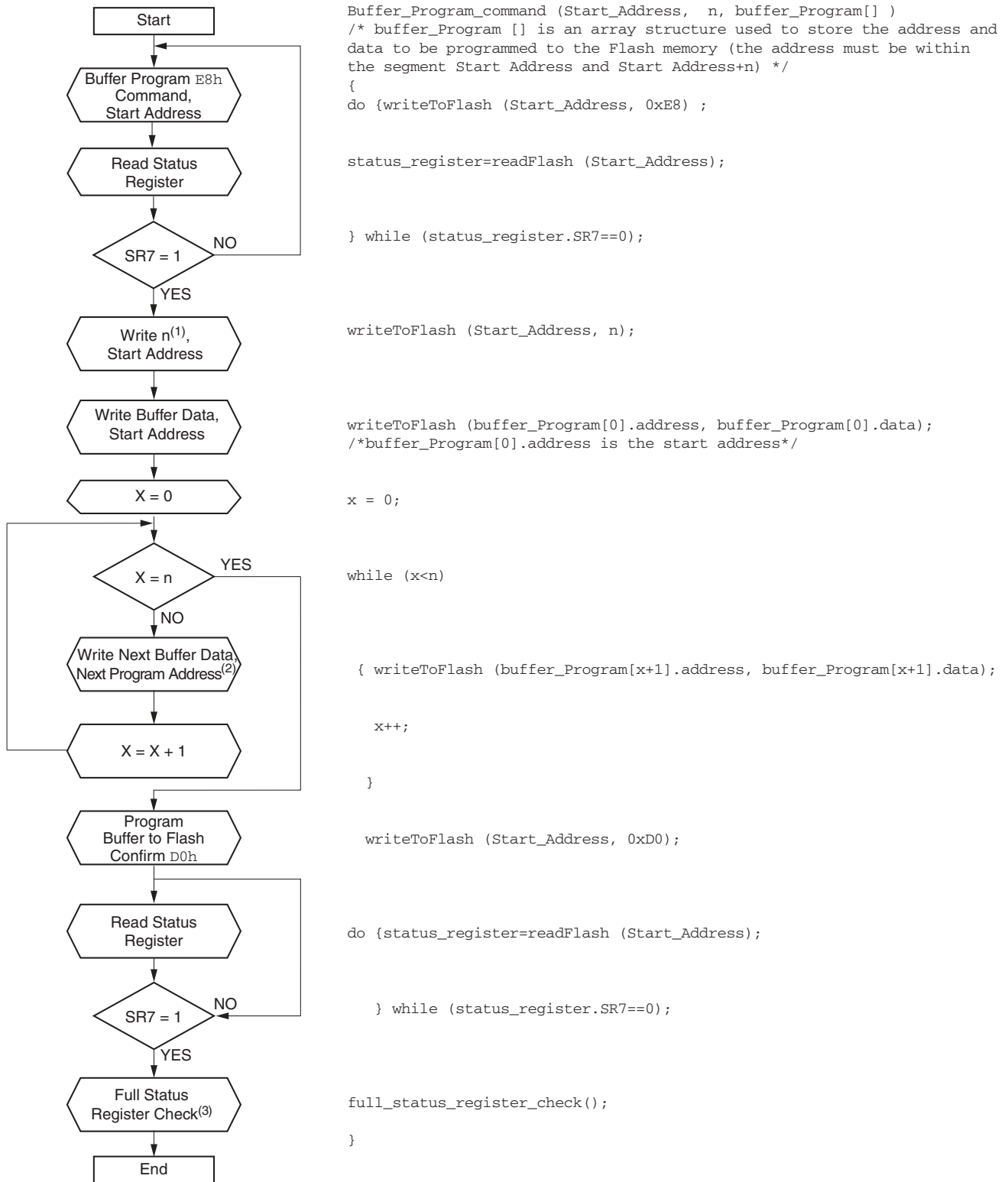

DS617_33_101608

Notes:

1. n + 1 is the number of data being programmed.
2. Next Program data is an element belonging to buffer_Program[].data; Next Program address is an element belonging to buffer_Program[].address
3. Routine for Error Check by reading SR3, SR4 and SR1.
4. To read the memory in Asynchronous mode, the CR15 Configuration Register bit must be written to 1.

Figure 39: Buffer Program Flowchart and Pseudocode

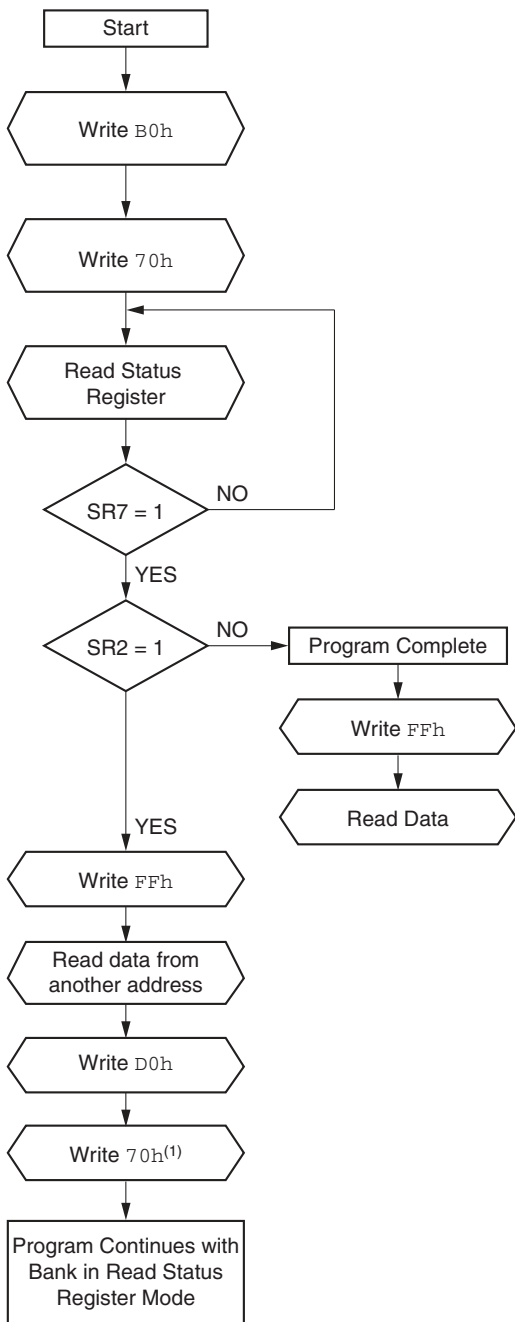

```

program_suspend_command ( ) {
    writeToFlash (any_address, 0xB0) ;

    writeToFlash (bank_address, 0x70) ;
    /* read status register to check if
    program has already completed */

do {
    status_register=readFlash (bank_address) ;
    /* E or G must be toggled*/

} while (status_register.SR7== 0) ;

if (status_register.SR2==0) /*program completed */
{ writeToFlash (bank_address, 0xFF) ;
  read_data ( ) ;
  /*The device returns to Read Array
  (as if program/erase suspend was not issued).*/
}
else
{ writeToFlash (bank_address, 0xFF) ;

  read_data ( ) ; /*read data from another address*/

  writeToFlash (any_address, 0xD0) ;
  /*write 0xD0 to resume program*/

  writeToFlash (bank_address, 0x70) ;
  /*read status register to check if program has completed */
}
}
    
```

DS617_34_101608

Notes:

1. The Read Status Register command (Write 70h) can be issued just before or just after the Program Resume command.
2. To read the memory in Asynchronous mode, the CR15 Configuration Register bit must be written to 1.

Figure 40: Program Suspend & Resume Flowchart and Pseudocode

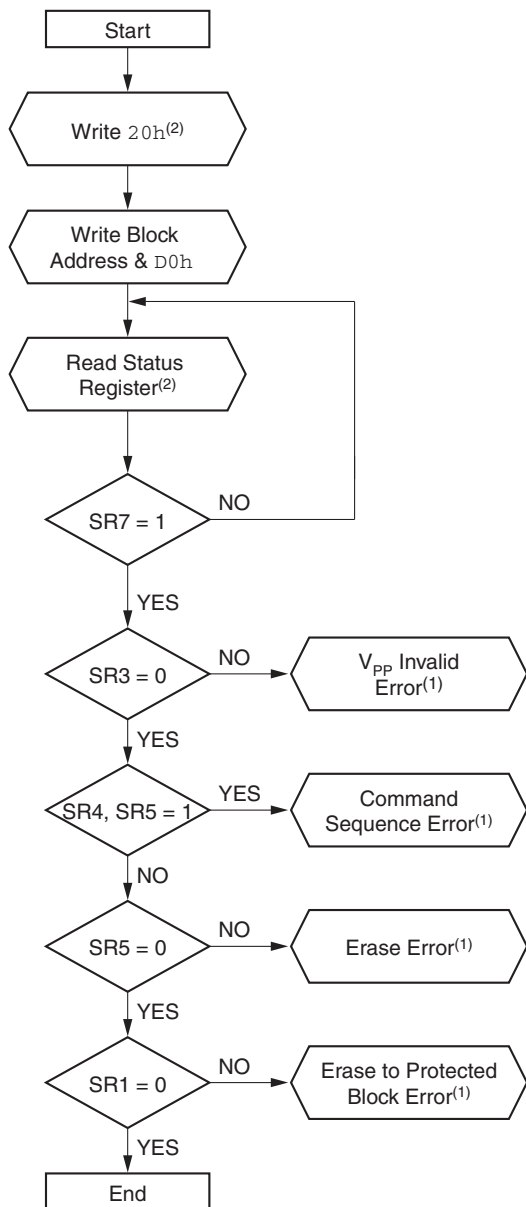

```

erase_command ( blockToErase ) {
    writeToFlash (blockToErase, 0x20) ;
    /*see note (2) */

    writeToFlash (blockToErase, 0xD0) ;
    /* Memory enters read status state after
    the Erase Command */

    do {
        status_register=readFlash (blockToErase) ;
        /* see note (2) */
        /* E or G must be toggled*/

    } while (status_register.SR7== 0) ;

    if (status_register.SR3==1) /*VPP invalid error */
        error_handler ( ) ;

    if ( (status_register.SR4==1) && (status_register.SR5==1) )
    /* command sequence error */
        error_handler ( ) ;

    if ( (status_register.SR5==1) )
    /* erase error */
        error_handler ( ) ;

    if (status_register.SR1==1) /*program to protect block error */
        error_handler ( ) ;

}
  
```

DS617_35_101608

Notes:

1. If an error is found, the Status Register must be cleared before further Program/Erase operations.
2. Any address within the bank can equally be used.
3. To read the memory in Asynchronous mode, the CR15 Configuration Register bit must be written to 1.

Figure 41: Block Erase Flowchart and Pseudocode

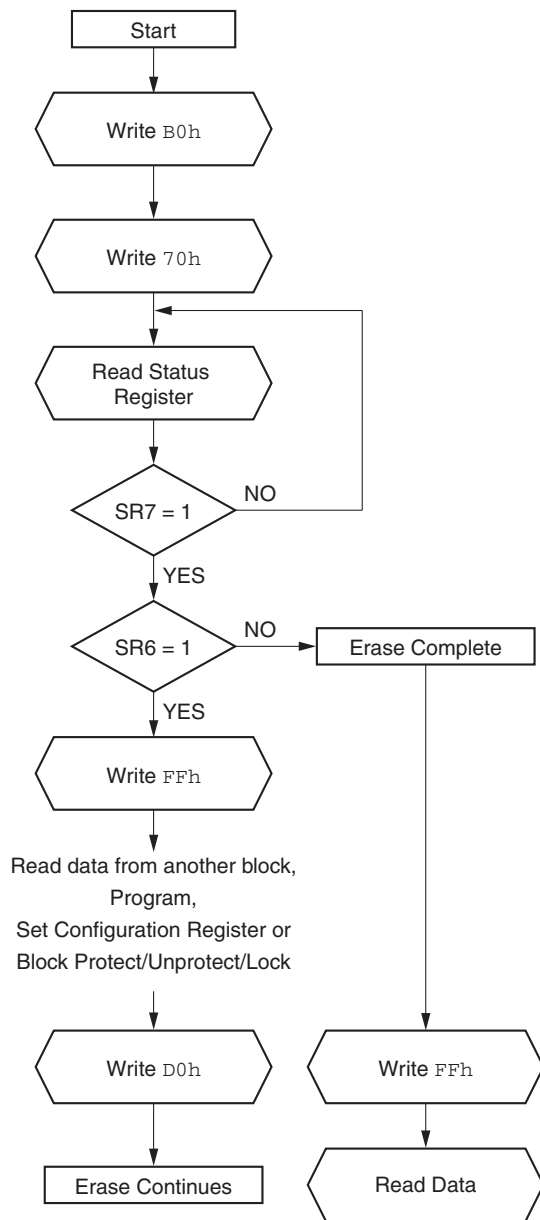

```

erase_suspend_command ( ) {
    writeToFlash (bank_address, 0xB0) ;

    writeToFlash (bank_address, 0x70) ;
    /* read status register to check if
    erase has already completed */

    do {
        status_register=readFlash (bank_address) ;
        /* E or G must be toggled*/
    } while (status_register.SR7== 0) ;

    if (status_register.SR6==0) /*erase completed */
    { writeToFlash (bank_address, 0xFF) ;

        read_data ( ) ;
        /*read data from another block*/
        /*The device returns to Read Array
        (as if program/erase suspend was not issued).*/

    }
    else
    { writeToFlash (bank_address, 0xFF) ;
      read_program_data ( ) ;
      /*read or program data from another address*/
      writeToFlash (bank_address, 0xD0) ;
      /*write 0xD0 to resume erase*/
    }
}
  
```

DS617_36_101608

Notes:

1. The Read Status Register command (Write 70h) can be issued just before or just after the Erase Resume command.
2. To read the memory in Asynchronous mode, the CR15 Configuration Register bit must be written to 1.

Figure 42: Erase Suspend & Resume Flowchart and Pseudocode

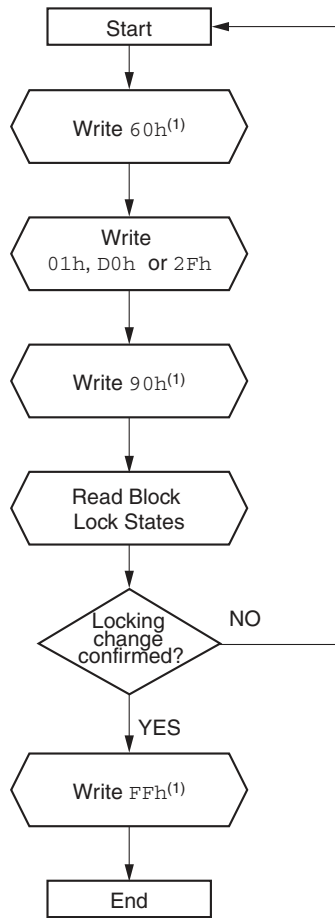

```

locking_operation_command (address, lock_operation) {
    writeToFlash (address, 0x60) ; /*configuration setup*/
    /* see note (1) */

    if (lock_operation==LOCK) /*to protect the block*/
        writeToFlash (address, 0x01) ;
    else if (lock_operation==UNLOCK) /*to unprotect the block*/
        writeToFlash (address, 0xD0) ;
    else if (lock_operation==LOCK-DOWN) /*to lock the block*/
        writeToFlash (address, 0x2F) ;

    writeToFlash (address, 0x90) ;
    /*see note (1) */

    if (readFlash (address) != locking_state_expected)
        error_handler () ;
    /*Check the locking state (see Read Block Signature table)*/

    writeToFlash (address, 0xFF) ; /*Reset to Read Array mode*/
    /*see note (1) */
}
    
```

DS617_37_101608

Notes:

1. Any address within the bank can equally be used.
2. To read the memory in Asynchronous mode, the CR15 Configuration Register bit must be written to 1.

Figure 43: Locking Operation Flowchart and Pseudocode

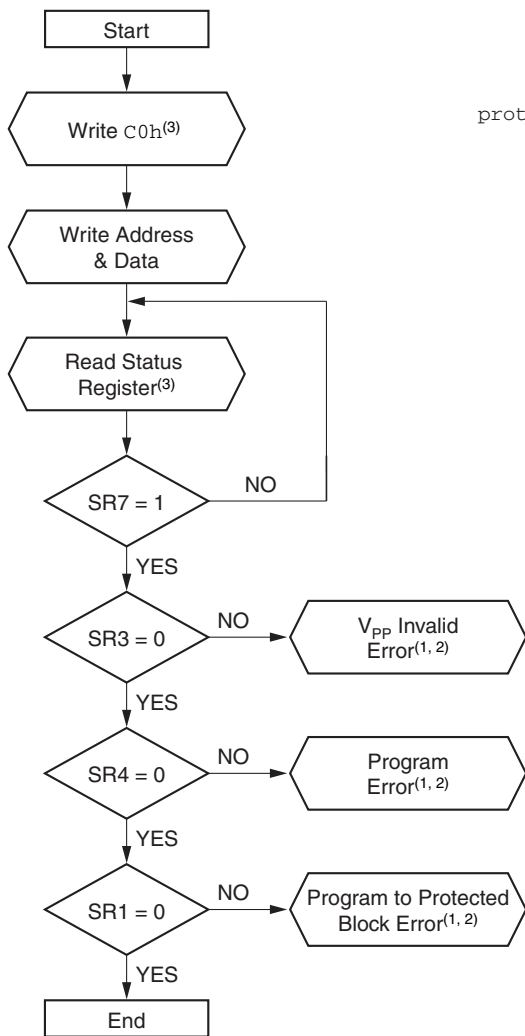

```

protection_register_program_command (addressToProgram, dataToProgram) {
    writeToFlash (addressToProgram, 0xC0) ;
    /*see note (3) */

    writeToFlash (addressToProgram, dataToProgram) ;
    /*Memory enters read status state after
    the Program Command*/

    do {
        status_register=readFlash (addressToProgram) ;
        /* see note (3) */
        /* E or G must be toggled*/

    } while (status_register.SR7== 0) ;

    if (status_register.SR3==1) /*VPP invalid error */
        error_handler ( ) ;

    if (status_register.SR4==1) /*program error */
        error_handler ( ) ;

    if (status_register.SR1==1) /*program to protect block error */
        error_handler ( ) ;

}
  
```

DS617_38_101608

Notes:

1. Status check of SR1 (Protected Block), SR3 (VPP Invalid) and SR4 (Program Error) can be made after each program operation or after a sequence.
2. If an error is found, the Status Register must be cleared before further Program/Erase Controller operations.
3. Any address within the bank can equally be used.
4. To read the memory in Asynchronous mode, the CR15 Configuration Register bit must be written to 1.

Figure 44: Protection Register Program Flowchart and Pseudocode

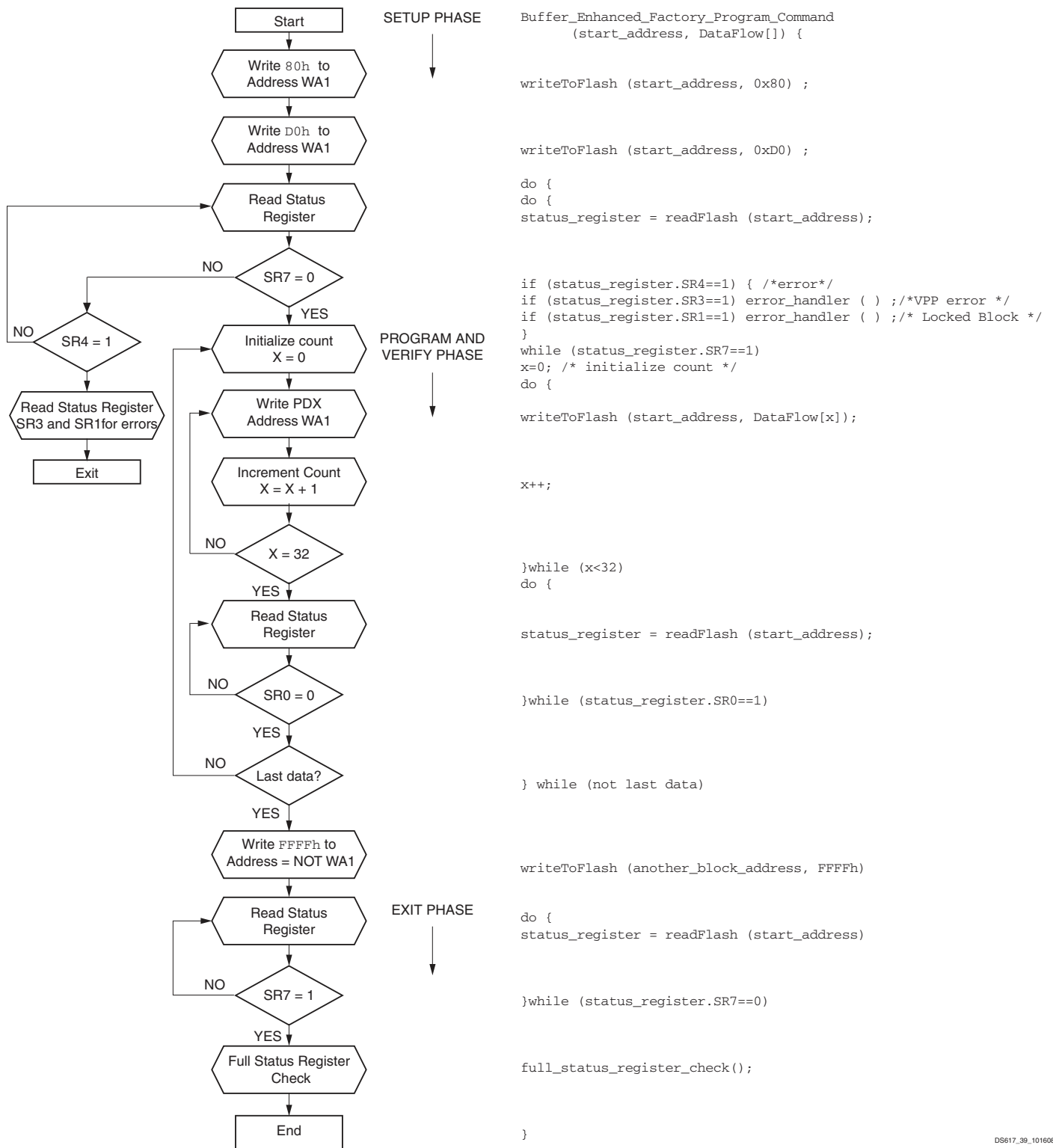

DS617_39_101608

Notes:

1. To read the memory in Asynchronous mode, the CR15 Configuration Register bit must be written to 1.

Figure 45: Buffer Enhanced Factory Program Flowchart and Pseudocode

Appendix D: Command Interface State Tables

Table 46: Command Interface States – Modify Table, Next State⁽¹⁾

Current CI State		Command Input											
		Read Array ⁽²⁾ (FFh)	Program Setup ⁽³⁾⁽⁴⁾ (10/40h)	Buffer Program ⁽³⁾⁽⁴⁾ (E8h)	Block Erase, Setup ⁽³⁾⁽⁴⁾ (20h)	BEFP Setup (80h)	Blank Check Setup (BCh)	Erase Confirm P/E Resume, Block Unlock Confirm, BEFP Confirm ⁽³⁾⁽⁴⁾ (D0h)	Blank Check confirm (C3h)	Buffer Program, Program/ Erase Suspend (B0h)	Read Status Register (70h)	Clear Status Register ⁽⁵⁾ (50h)	Read Electronic Signature, Read CFI Query
Ready	Ready	Program Setup	BP Setup	Erase Setup	BEFP Setup	Blank Check setup	Ready						
Lock/CR Setup	Ready (Lock Error)						Ready (unlock block)	Ready (Lock Error)					
OTP	Setup	OTP Busy											
	Busy	OTP Busy	IS in OTP Busy	OTP busy	IS in OTP Busy	OTP Busy							
	IS in OTP busy	OTP Busy											
Program	Setup	Program Busy											
	Busy	Program Busy	IS in Program Busy	Program Busy	IS in Program Busy	Program Busy	Prog. Susp.	Program Busy					
	IS in Program Busy	Program Busy											
	Suspend	PS	IS in PS	PS	IS in Program Suspend	PS	Program Busy	Program Suspend					
	IS in PS	Program Suspend											
Buffer Program	Setup	Buffer Program Load 1 (give word count load (N-1))											
	Buffer Load 1	if N=0 go to Buffer Program Confirm. Else (N. 0) go to Buffer Program Load 2 (data load)											
	Buffer Load 2	Buffer Program Confirm when count =0;Else Buffer Program Load 2 ⁽⁷⁾											
	Confirm	Ready (error)				BP Busy			Ready (error)				
	Busy	BP Busy	IS in BP Busy	BP Busy	IS in BP Busy	BP Busy			BP Susp.	Buffer Program Busy			
	IS in BP Busy	Buffer Program Busy											
	Suspend	BP Suspend	IS in BP Suspend	BP Suspend	IS in BP Suspend	BP Suspend	BP busy	Buffer Program Suspend					
	IS in BP Suspend	Buffer Program Suspend											

Table 46: Command Interface States – Modify Table, Next State⁽¹⁾ (Cont'd)

Current CI State	Command Input										
	Read Array ⁽²⁾ (7F7h)	Program Setup ⁽³⁾⁽⁴⁾ (10/40h)	Buffer Program ⁽³⁾⁽⁴⁾ (E8h)	Block Erase, Setup ⁽³⁾⁽⁴⁾ (20h)	BEFP Setup (80h)	Blank Check Setup (BCh)	Erase Confirm P/E Resume, Block Unlock Confirm, BEFP Confirm ⁽³⁾⁽⁴⁾ (D0h)	Blank Check confirm (C3h)	Buffer Program, Program/ Erase Suspend (B0h)	Read Status Register (70h)	Clear Status Register ⁽⁵⁾ (50h)
Erase	Setup Ready (error)				Erase Busy			Ready (error)			
	Busy	Erase Busy	IS in Erase Busy	Erase Busy	IS in Erase Busy	Erase Busy	Erase Suspend	Erase Busy			
	IS in Erase Busy	Erase Busy									
	Suspend	Erase Suspend	Program in ES	BP in ES	IS in Erase Suspend	ES	Erase Busy	Erase Suspend			
	IS in ES	Erase Suspend									
Program in Erase Suspend	Setup Program Busy in Erase Suspend										
	Busy	Program Busy in ES	IS in Program Busy in ES	Program Busy in ES	IS in Program Busy in ES	Program Busy in ES		PS in ES	Program Busy in Erase Suspend		
	IS in Program busy in ES	Program busy in Erase Suspend									
	Suspend	PS in ES	IS in PS in ES	PS in ES	IS in Program						
	Suspend in ES	PS in ES	Program Busy in ES	Program Suspend in Erase Suspend							
	IS in PS in ES	Program Suspend in Erase Suspend									
Buffer Program in Erase Suspend	Setup	Buffer Program Load 1 in Erase Suspend (give word count load (N-1)); if N=0 go to Buffer Program confirm. Else (N. 0) go to Buffer Program Load 2									
	Buffer Load 1	Buffer Program Load 2 in Erase Suspend (data load)									
	Buffer Load 2	Buffer Program Confirm in Erase Suspend when count =0; Else Buffer Program Load 2 in Erase Suspend (note: Buffer Program will fail at this point if any block address is different from the first address)									
	Confirm	Erase Suspend (sequence error)					BP Busy in ES	Erase Suspend (sequence error)			
	Busy	BP Busy in ES	IS in BP Busy in ES	BP busy in ES	IS in BP busy in ES	BP Busy in ES		BP Susp. in ES	Buffer Program Busy in ES		
	IS in BP busy in ES	Buffer Program Busy in Erase Suspend									

Table 46: Command Interface States – Modify Table, Next State⁽¹⁾ (Cont'd)

Current CI State		Command Input										
		Read Array ⁽²⁾ (1Fh)	Program Setup ⁽³⁾⁽⁴⁾ (10/40h)	Buffer Program ⁽³⁾⁽⁴⁾ (E8h)	Block Erase, Setup ⁽³⁾⁽⁴⁾ (20h)	BEFP Setup (80h)	Blank Check Setup (BC1h)	Erase Confirm P/E Resume, Block Unlock Confirm, BEFP Confirm ⁽³⁾⁽⁴⁾ (D0h)	Blank Check confirm (CBh)	Buffer Program, Program/ Erase Suspend (B0h)	Read Status Register (70h)	Clear Status Register ⁽⁵⁾ (50h)
Buffer Program in Erase Suspend (Cont'd)	Suspend	BP Suspend in ES	IS in BP Suspend in ES	BP Suspend in ES	IS in BP Suspend in Erase Suspend	BP Suspend in ES	BP Busy in Erase Suspend	Buffer Program Suspend in Erase Suspend				
	IS in BP Suspend in ES	BP Suspend in Erase Suspend										
Blank Check	Setup	Ready (error)						Blank Check busy	Ready (error)			
	Busy	Blank Check busy	IS in Blank Check busy	Blank Check busy	IS in Blank Check busy	Blank Check busy						
Lock/CR Setup in Erase Suspend	Erase Suspend (Lock Error)				Erase Suspend		Erase Suspend (Lock Error)					
Buffer EFP	Setup	Ready (error)					BEFP Busy	Ready (error)				
	Busy	BEFP Busy ⁽⁶⁾										

Notes:

1. CI = Command Interface; CR = Configuration register; BEFP = Buffer Enhanced Factory program; P/E C = Program/Erase controller; IS = Illegal State; BP = Buffer Program; ES = Erase Suspend.
2. At power-up, all banks are in Read Array mode. Issuing a Read Array command to a busy bank, results in undetermined data output.
3. The two cycle command should be issued to the same bank address.
4. If the P/E C is active, both cycles are ignored.
5. The Clear Status Register command clears the SR error bits except when the P/E C. is busy or suspended.
6. BEFP is allowed only when Status Register bit SR0 is reset to '0'. BEFP is busy if Block Address is first BEFP Address. Any other commands are treated as data.
7. Buffer Program will fail at this point if any block address is different from the first address.

Table 47: Command Interface States – Modify Table, Next Output State^(1,2)

Current CI State	Command Input										
	Read Array ⁽³⁾ (F7h)	Program Setup ⁽⁴⁾⁽⁵⁾ (10/40h)	Buffer Program (33h)	Block Erase, Setup ⁽⁴⁾⁽⁵⁾ (20h)	BEFP Setup (80h)	Blank Check Setup (BCh)	Erase Confirm P/E Resume, Block Unlock Confirm, BEFP Confirm ⁽⁴⁾⁽⁵⁾ (D0h)	Blank Check confirm (CBh)	Program/ Erase Suspend (B0h)	Read Status Register (70h)	Clear Status Register (50h)
Program Setup	Status Register										
Erase Setup											
OTP Setup											
Program Setup in Erase Suspend											
BEFP Setup											
BEFP Busy											
Buffer Program Setup											
Buffer Program Load 1											
Buffer Program Load 2											
Buffer Program Confirm											
Buffer Program Setup in Erase Suspend											
Buffer Program Load 1 in Erase Suspend											
Buffer Program Load 2 in Erase Suspend											
Buffer Program Confirm in Erase Suspend											
Blank Check setup											
Lock/CR Setup											
Lock/CR Setup in Erase Suspend											

Table 47: Command Interface States – Modify Table, Next Output State^(1,2) (Cont'd)

Current CI State	Command Input										
	Read Array ⁽³⁾ (F7h)	Program Setup ⁽⁴⁾⁽⁵⁾ (10/40h)	Buffer Program (38h)	Block Erase, Setup ⁽⁴⁾⁽⁵⁾ (20h)	BEFP Setup (80h)	Blank Check Setup (BCh)	Erase Confirm P/E Resume, Block Unlock Confirm, BEFP Confirm ⁽⁴⁾⁽⁵⁾ (D0h)	Blank Check confirm (CBh)	Program/ Erase Suspend (B0h)	Read Status Register (70h)	Clear Status Register (50h)
OTP Busy	Array	Status Register	Status Register	Output Unchanged	Status Register	Output Unchanged	Status Register	Output Unchanged	Status Register	Output Unchanged	Status Register
Ready											Electronic Signature/ CFI
Program Busy											
Erase Busy											
Buffer Program Busy											
Program/Erase Suspend											
Buffer Program Suspend											
Program Busy in Erase Suspend											
Buffer Program Busy in Erase Suspend											
Program Suspend in Erase Suspend											
Buffer Program Suspend in Erase Suspend											
Blank Check busy											
Illegal State											

Notes:

1. The output state shows the type of data that appears at the outputs if the bank address is the same as the command address. A bank can be placed in Read Array, Read Status Register, Read Electronic Signature or Read CFI mode, depending on the command issued. Each bank remains in its last output state until a new command is issued to that bank. The next state does not depend on the bank output state.
2. CI = Command Interface: CR = Configuration Register: BEFP = Buffer Enhanced Factory Program: P/E. C. = Program/Erase Controller.
3. At Power-Up, all banks are in Read Array mode. Issuing a Read Array command to a busy bank, results in undetermined data output.
4. The two cycle command should be issued to the same bank address.
5. If the P/E.C. is active, both cycles are ignored.

Table 48: Command Interface States – Lock Table, Next State⁽¹⁾

Current CI State	Command Input							
	Lock/CR Setup ⁽²⁾ (60h)	OTP Setup ⁽²⁾ (c0h)	Block Lock Confirm (01h)	Block Lock-Down Confirm (2Fh)	Set CR Confirm (03h)	Block Address (WAO) ⁽³⁾ (xxxxh)	Illegal Command ⁽⁴⁾	P/E C Operation Completed ⁽⁵⁾
Ready	Lock/CR Setup	OTP Setup	Ready					–
Lock/CR Setup	Ready (Lock error)		Ready			Ready (Lock error)		–
OTP	Setup	OTP Busy x						–
	Busy	IS in OTP Busy	OTP Busy				Ready	
	IS in OTP busy	OTP Busy					IS Ready	
Program	Setup	Program Busy						–
	Busy	IS in Program Busy	Program Busy					Ready
	IS in Program busy	Program Busy						IS Ready
	Suspend	IS in PS	Program Suspend				–	
	IS in PS	Program Suspend						–
Buffer Program	Setup	Buffer Program Load 1 (give word count load (N-1))						–
	Buffer Load 1	Buffer Program Load 2 ⁽⁶⁾				Exit	see note (6)	–
	Buffer Load 2	Buffer Program Confirm when count =0; Else Buffer Program Load 2 ⁽⁹⁾						–
	Confirm	Ready (error)						–
	Busy	IS in BP Busy	Buffer Program Busy				Ready	
	IS in Buffer Program busy	Buffer Program Busy						IS Ready
	Suspend	IS in BP Suspend	Buffer Program Suspend				–	
	IS in BP Suspend	Buffer Program Suspend						–
Erase	Setup	Ready (error)						–
	Busy	IS in Erase Busy	Erase Busy				Ready	
	IS in Erase busy	Erase Busy						IS ready
	Suspend	Lock/CR Setup in ES	IS in ES	Erase Suspend			–	
	IS in ES	Erase Suspend						–
Program in Erase Suspend	Setup	Program Busy in Erase Suspend						–
	Busy	IS in Program busy in ES	Program Busy in Erase Suspend				ES	
	IS in Program busy in ES	Program Busy in Erase Suspend						IS in ES
	Suspend	IS in PS in ES	Program Suspend in Erase Suspend			–		
	IS in PS in ES	Program Suspend in Erase Suspend						–

Table 48: Command Interface States – Lock Table, Next State⁽¹⁾ (Cont'd)

Current CI State	Command Input									
	Lock/CR Setup ⁽²⁾ (60h)	OTP Setup ⁽²⁾ (c0h)	Block Lock Confirm (01h)	Block Lock-Down Confirm (2Fh)	Set CR Confirm (03h)	Block Address (WA0) ⁽³⁾ (xxxxh)	Illegal Command ⁽⁴⁾	P/E C Operation Completed ⁽⁵⁾		
Buffer Program in Erase Suspend	Setup	Buffer Program Load 1 in Erase Suspend (give word count load (N-1))							-	
	Buffer Load 1	Buffer Program Load 2 in Erase Suspend ⁽⁷⁾				Exit	see note (7)			
	Buffer Load 2	Buffer Program Confirm in Erase Suspend when count =0; Else Buffer Program Load 2 in Erase Suspend ⁽⁹⁾								
	Confirm	Erase Suspend (sequence error)								
	Busy	IS in BP busy in ES	Buffer Program Busy in Erase Suspend					ES		
	IS in BP busy in ES	BP busy in ES								IS in ES
	Suspend	IS in BP suspend in ES	Buffer Program Suspend in Erase Suspend					-		
	IS in BP Suspend in ES	Buffer Program Suspend in Erase Suspend								
Blank Check	Setup	Ready (error)							-	
	Blank Check busy	IS in Blank Check busy	Blank Check busy					Ready		
Lock/CR Setup in ES		Erase Suspend (Lock error)	Erase Suspend		Erase Suspend (Lock error)			-		
BEFP	Setup	Ready (error)							-	
	Busy	BEFP Busy ⁽⁸⁾				Exit	BEFP Busy ⁽⁸⁾	-		

Notes:

1. CI = Command Interface; CR = Configuration register; BEFP = Buffer Enhanced Factory program; P/E C = Program/Erase controller; IS = Illegal State; BP = Buffer program; ES = Erase suspend; WA0 = Address in a block different from first BEFP address.
2. If the P/E C is active, both cycle are ignored.
3. BEFP Exit when Block Address is different from first Block Address and data are FFFFh.
4. Illegal commands are those not defined in the command set.
5. -: not available. In this case the state remains unchanged.
6. If N = 0 go to Buffer Program Confirm. Else (not = 0) go to Buffer Program Load 2 (data load)
7. If N = 0 go to Buffer Program Confirm in Erase suspend. Else (not = 0) go to Buffer Program Load 2 in Erase suspend.
8. BEFP is allowed only when Status Register bit SR0 is set to '0'. BEFP is busy if Block Address is first BEFP Address. Any other commands are treated as data.
9. Buffer Program will fail at this point if any block address is different from the first address

Table 49: Command Interface States – Lock Table, Next Output State^(1,2)

Current CI State	Command Input									
	Lock/CR Setup ⁽³⁾ (60h)	Blank Check setup (BCh)	OTP Setup ⁽³⁾ (C0h)	Blank Check Confirm (CBh)	Block Lock Confirm (01h)	Block Lock-Down Confirm (2Fh)	Set CR Confirm (03h)	BEFP Exit ⁽⁴⁾ (FFFFh)	Illegal Command ⁽⁵⁾	P. E./C. Operation Completed
Program Setup	Status Register									Output Unchanged
Erase Setup										
OTP Setup										
Program Setup in Erase Suspend										
BEFP Setup										
BEFP Busy										
Buffer Program Setup										
Buffer Program Load 1										
Buffer Program Load 2										
Buffer Program Confirm										
Buffer Program Setup in Erase Suspend										
Buffer Program Load 1 in Erase Suspend										
Buffer Program Load 2 in Erase Suspend										
Buffer Program Confirm in Erase Suspend										
Blank Check setup										
Lock/CR Setup										
Lock/CR Setup in Erase Suspend										

Table 49: Command Interface States – Lock Table, Next Output State^(1,2) (Cont'd)

Current CI State	Command Input									
	Lock/CR Setup ⁽³⁾ (60h)	Blank Check setup (BCh)	OTP Setup ⁽³⁾ (C0h)	Blank Check Confirm (CBh)	Block Lock Confirm (01h)	Block Lock-Down Confirm (2Fh)	Set CR Confirm (03h)	BEFP Exit ⁽⁴⁾ (FFFh)	Illegal Command ⁽⁵⁾	P. E./C. Operation Completed
OTP Busy	Status Register			Output Unchanged			Array		Output Unchanged	
Ready										
Program Busy										
Erase Busy										
Buffer Program Busy										
Program/Erase Suspend										
Buffer Program Suspend										
Program Busy in Erase Suspend										
Buffer Program Busy in Erase Suspend										
Program Suspend in Erase Suspend										
Buffer Program Suspend in Erase Suspend										
Blank Check busy										
Illegal State										

Notes:

1. The output state shows the type of data that appears at the outputs if the bank address is the same as the command address. A bank can be placed in Read Array, Read Status Register, Read Electronic Signature or Read CFI mode, depending on the command issued. Each bank remains in its last output state until a new command is issued to that bank. The next state does not depend on the bank's output state.
2. CI = Command Interface; CR = Configuration Register; BEFP = Buffer Enhanced Factory Program; P/E. C. = Program/Erase Controller.
3. If the P/E.C. is active, both cycles are ignored.
4. BEFP Exit when Block Address is different from first Block Address and data are FFFFh.
5. Illegal commands are those not defined in the command set.

Revision History

The following table shows the revision history for this document.

Date	Version	Revision
12/13/2007	1.0	Initial Xilinx release.
03/31/2008	2.0	<p>Added bus operations and advance device specifications:</p> <ul style="list-style-type: none"> • Expanded "Command Interface," page 14, adding new sections. • Added the following sections: <ul style="list-style-type: none"> ◆ "Status Register," page 23 ◆ "Configuration Register," page 26 ◆ "Read Modes," page 34 ◆ "Dual Operations and Multiple Bank Architecture," page 35 ◆ "Block Locking," page 37 ◆ "Power-On Reset," page 39 ◆ "First Address Latching Sequence," page 41 ◆ "Program and Erase Times and Endurance Cycles," page 44 ◆ "Maximum Rating," page 45 ◆ "DC and AC Parameters," page 45 ◆ "Appendix A: Block Address Tables," page 61 ◆ "Appendix B: Common Flash Interface," page 65 ◆ "Appendix C: Flowcharts and Pseudocodes," page 71 ◆ "Appendix D: Command Interface State Tables," page 80 <p>Other corrections and updates:</p> <ul style="list-style-type: none"> • Corrected resistor values in Figure 7, page 10. • Corrected resistor values and removed external resistors from signal K in Figure 8, page 11. • Updated "Marking Information," page 61.
05/14/2008	2.1	<ul style="list-style-type: none"> • Data sheet status changed from Advance to Preliminary. • Corrected the nomenclature for the FT64 package. • Replaced section "FPGA Master BPI-Up Configuration Mode." with section "Alternate Configuration Modes," page 11. • Updated Figure 18, page 40 with annotations for T_{VDDPOR}. • Updated Table 21, page 44 to show correct values of V_{PP}. • Updated Table 31, page 58. • Updated trademark references.
10/29/2008	2.2	<ul style="list-style-type: none"> • Minor corrections throughout. • Updated Figure 1, page 2, Figure 7, page 12, Figure 8, page 22, Figure 12, page 31, Figure 15, page 33, Figure 17, page 39, Figure 18, page 40, and Figure 24, page 46. • Updated Figure 14, page 32, Figure 16, page 33, Figure 20, page 42, Figure 33, page 58, and Figure 34, page 59 to reflect changed timing parameter nomenclature. • Added maximum rating for junction temperature to Table 22, page 45. • Added Table 24, page 46. • Updated Table 2, page 6, Table 4, page 9, Table 9, page 21, Table 21, page 44, and Table 44, page 69. • Added new voltage range information to Table 28, page 50. • Updated Table 32, page 59 to reflect changed timing parameter nomenclature. • Updated Table 19, page 42, Table 20, page 43, Table 29, page 52, Table 30, page 56, Table 31, page 58, and Table 33, page 60. (Added new voltage range information and updated tables to reflect changed timing parameter nomenclature.)

Date	Version	Revision
11/30/2009	3.0	<ul style="list-style-type: none"> • See XCN09032, <i>DS617, High-Density Configuration and Storage Device Data Sheet Revision, v3.0</i>, for detailed product revisions: • Product change from preliminary to production phase. • Updated "Features" section. • Removed references and placeholders to V_{DDQ} operation in the 1.7V to 2.0V range. • Added support for Virtex-6 FPGAs. • Removed Figure 7, containing a detailed system application schematic. User is referred to duplicated schematic in UG438, <i>Platform Flash XL Configuration and Storage Device User Guide</i>. • Inserted notes in "Description," page 1 regarding Platform Flash XL support. • Updated Platform Flash XL configuration instructions in "FPGA Configuration Overview," page 8. • Configuration sequence removed from "Slave SelectMAP Configuration Mode," page 9. User is referred to the Configuration Interface section of the respective FPGA Configuration User Guide. • Removed Master SelectMAP Mode and Master BPI-Up Mode subheadings from "Alternate Configuration Modes," page 9. User is referred to UG438, <i>Platform Flash XL Configuration and Storage Device User Guide</i>. • Updated Figure 21, page 41. • Updated Table 4, page 8, Table 29, page 50, Table 33, page 58.
01/07/2010	3.0.1	Made typographical edits.
08/05/2015	4.0	This product is obsolete/discontinued per XCN15008 . Updated "Notice of Disclaimer".

Notice of Disclaimer

The information disclosed to you hereunder (the "Materials") is provided solely for the selection and use of Xilinx products. To the maximum extent permitted by applicable law: (1) Materials are made available "AS IS" and with all faults, Xilinx hereby DISCLAIMS ALL WARRANTIES AND CONDITIONS, EXPRESS, IMPLIED, OR STATUTORY, INCLUDING BUT NOT LIMITED TO WARRANTIES OF MERCHANTABILITY, NON-INFRINGEMENT, OR FITNESS FOR ANY PARTICULAR PURPOSE; and (2) Xilinx shall not be liable (whether in contract or tort, including negligence, or under any other theory of liability) for any loss or damage of any kind or nature related to, arising under, or in connection with, the Materials (including your use of the Materials), including for any direct, indirect, special, incidental, or consequential loss or damage (including loss of data, profits, goodwill, or any type of loss or damage suffered as a result of any action brought by a third party) even if such damage or loss was reasonably foreseeable or Xilinx had been advised of the possibility of the same. Xilinx assumes no obligation to correct any errors contained in the Materials or to notify you of updates to the Materials or to product specifications. You may not reproduce, modify, distribute, or publicly display the Materials without prior written consent. Certain products are subject to the terms and conditions of Xilinx's limited warranty, please refer to Xilinx's Terms of Sale which can be viewed at www.xilinx.com/legal.htm#tos; IP cores may be subject to warranty and support terms contained in a license issued to you by Xilinx. Xilinx products are not designed or intended to be fail-safe or for use in any application requiring fail-safe performance; you assume sole risk and liability for use of Xilinx products in such critical applications, please refer to Xilinx's Terms of Sale which can be viewed at www.xilinx.com/legal.htm#tos.