

TPS22990 Load Switch Evaluation Module

The TPS22990 evaluation module (EVM) allows the user to connect power to and control the 10-pin WSON package load switch. Parameters such as the on-resistance, rise time, and output pull-down resistance are easily and accurately evaluated. [Table 1](#) lists a short description of the TPS22990 and TPS22990N load switch performance specifications; for additional details on load switch performance, application notes, and the data sheet, see www.ti.com/loadswitch.

Table 1. TPS22990 Rise Time, Output Current Rating, Enable, and Output Discharge Characteristics

EVM	Device	Rise Time Typical (μ s)	V_{IN} (V)	Maximum Continuous Current (A)	Enable (ON Pin)	Quick Output Discharge
HVL152-001	TPS22990	Adjustable	0.6 to 5.5	10	Active High	Yes
HVL152-002	TPS22990N	Adjustable	0.6 to 5.5	10	Active High	No

Contents

1	Introduction	2
1.1	Description	2
1.2	Features	2
2	Electrical Performance	2
3	Schematic	2
4	Layout	3
4.1	Setup	4
5	Operation	4
6	Test Configurations	5
6.1	On-Resistance (R_{ON}) Test Setup	5
6.2	Rise Time Test Setup	6
6.3	V_{OUT} Rise Time Example	7
7	Bill of Materials (BOM)	8

List of Figures

1	TPS22990 EVM Schematic	2
2	TPS22990 EVM Top Layout	3
3	TPS22990 EVM Bottom Layout	3
4	R_{ON} Test Setup	5
5	Rise Time Test Setup	6
6	TPS22990 V_{OUT} t_R Example ($V_{IN} = 5$ V, $V_{BIAS} = 5$ V, $C_T = 0$ pF, $R_L = 10$ Ω)	7

List of Tables

1	TPS22990 Rise Time, Output Current Rating, Enable, and Output Discharge Characteristics	1
2	Bill of Materials TPS22990 EVM	8

1 Introduction

1.1 Description

The TPS22990EVM is a two-layer PCB containing the TPS22990 load switch device, and the TPS22990NEVM is a two-layer PCB containing the TPS22990N load switch device. The VIN and VOUT connections to the device and the PCB layout routing are capable of handling high continuous currents and provide a low-resistance pathway into and out of the device under test. Test point connections allow the EVM user to control the device with user-defined test conditions and make accurate R_{ON} measurements.

1.2 Features

This EVM has the following features:

- V_{IN} input voltage range: 0.6 V to 5.5 V
- 10-A maximum continuous current operation
- Connection points to VIN, VOUT, VBIAS, ON, PG pins as well as SENSE connections for accurate measurement of VIN and VOUT voltages
- Onboard C_{IN} , C_{OUT} , and CT capacitors
- Power Good (PG) signal can be monitored via test point

2 Electrical Performance

Refer to the data sheet [SLVSDK1](#) for detailed electrical characteristics of the TPS22990.

3 Schematic

Figure 1 illustrates the EVM schematic.

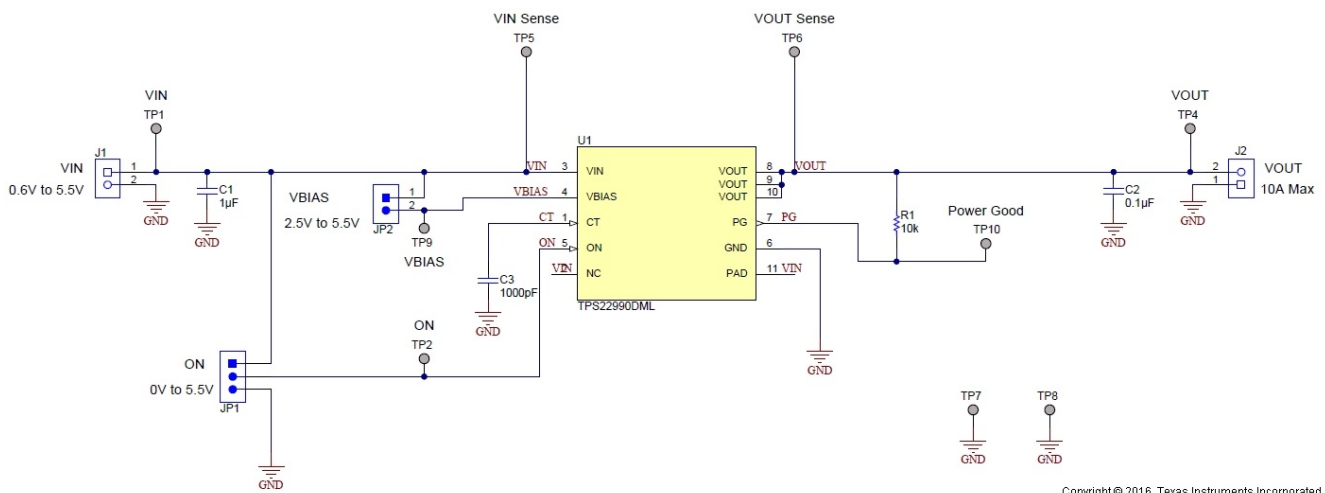

Copyright © 2016, Texas Instruments Incorporated

Figure 1. TPS22990 EVM Schematic

4 Layout

Figure 2 and Figure 3 show the PCB layout images.

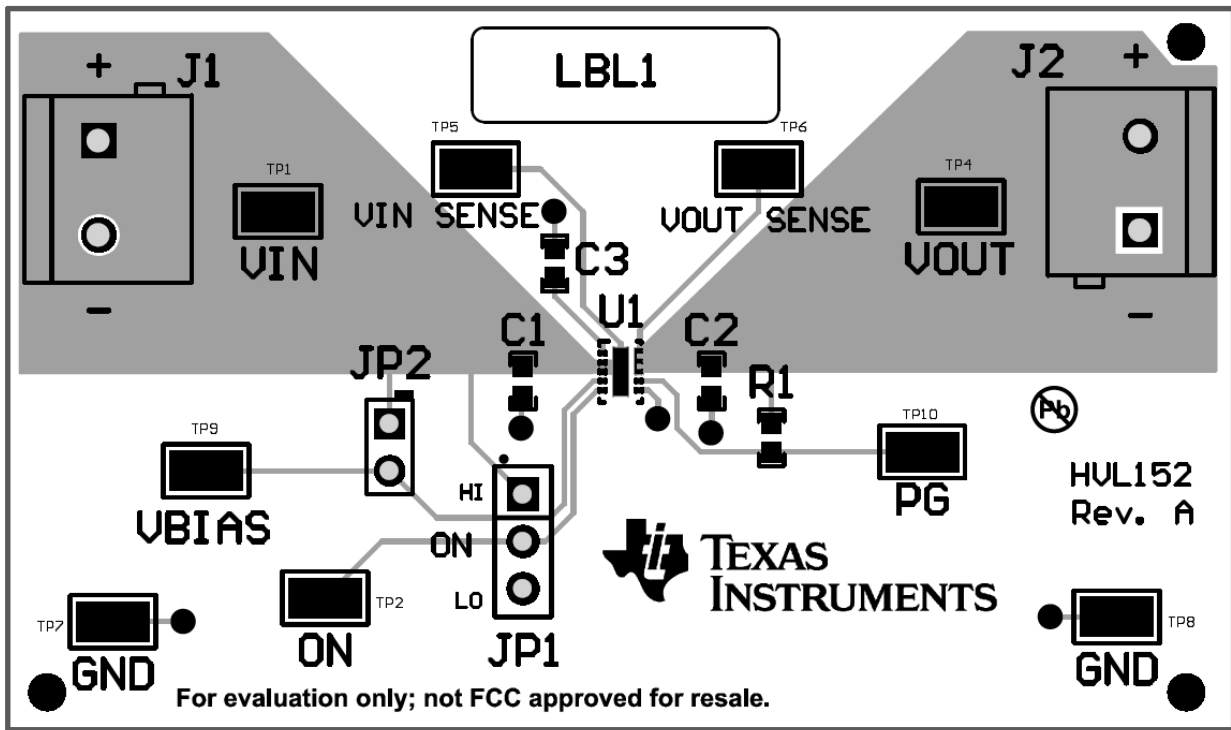

Figure 2. TPS22990 EVM Top Layout

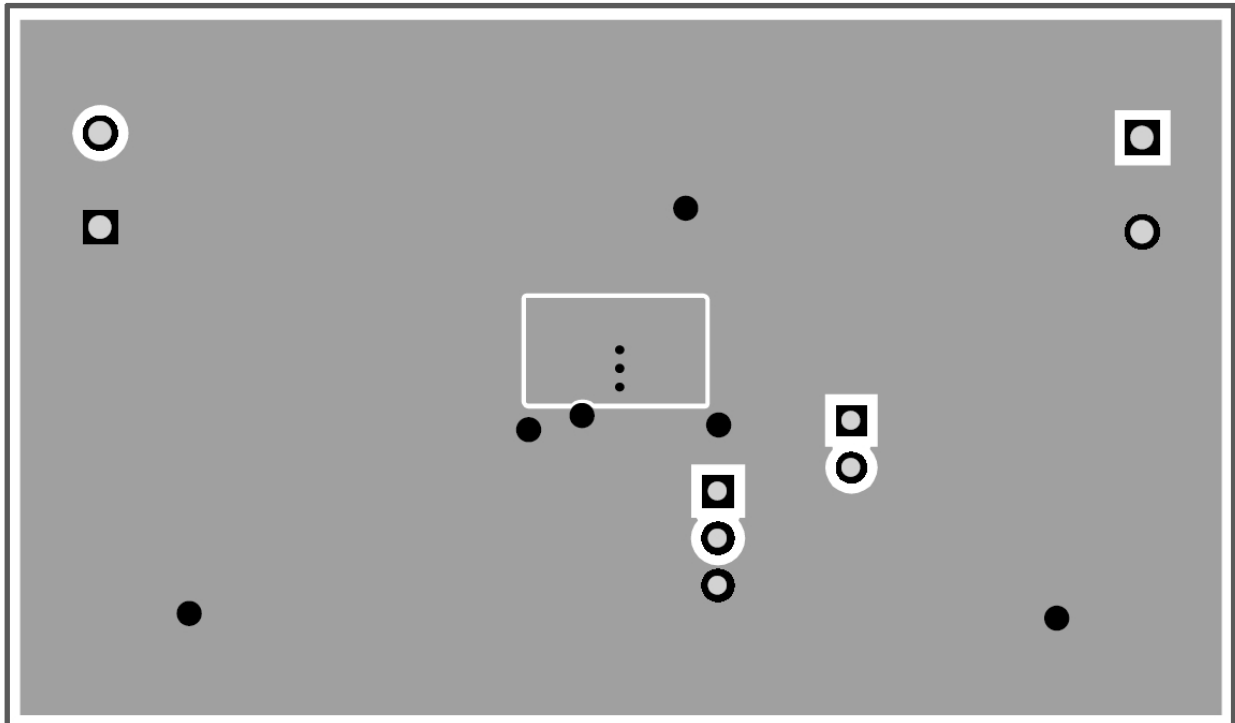

Figure 3. TPS22990 EVM Bottom Layout

4.1 Setup

This section describes the jumpers and connectors on the EVM as well as how to properly connect, set up, and use the EVM.

4.1.1 J1, TP1 – Input Connection

This is the connection for the leads from the input source. Connect the positive lead to the + terminal (VIN) and the negative lead to the – terminal (GND).

4.1.2 J2, TP4 – Output Connection

This is the connection for the output of the EVM. Connect the positive lead to the + terminal (VOUT) and the negative lead to the – terminal (GND).

4.1.3 JP1, TP2 – ON

This is the enable input for the device. A shorting jumper must be installed on JP1 in either the high or low position. The TPS22990 is active high, and ON must not be left floating. An external enable source can be applied to the EVM by removing the shunt and connecting a signal to TP2. Refer to the data sheet for proper ON and OFF voltage level settings. A switching signal may also be used and connected at this point.

4.1.4 JP2, TP9 – VBIAS Power

This jumper connects VBIAS to the VIN voltage source. VBIAS must be maintained between 2.5 V–5.5 V for proper operation on the TPS22990 device. If testing conditions involve taking the VIN voltage below 2.5 V, remove the shunt across JP2 and connect VBIAS voltage at TP9.

4.1.5 TP10 – Power Good (PG)

This test point is used to monitor the PG pin voltage which is tied to VOUT through a 10-k Ω resistor.

4.1.6 TP5 - VIN Sense, TP6 - VOUT Sense

These two connections are used when very accurate measurements of the input or output are required. Make R_{ON} measurements using these sense connections when measuring the voltage drop from VIN to VOUT.

4.1.7 TP7, TP8 – GND

These are connections to GND.

5 Operation

Connect the V_{IN} power supply to the J1 terminal (VIN). The input voltage range of the TPS22990 EVM is 0.6 V to 5.5 V.

External output loads can be applied to the switch by using the J2 terminal (VOUT). The TPS22990 EVM is rated for a maximum continuous current of 10 A. A shunt on JP1 must be installed for proper operation. When the ON pin is asserted high, the output of the TPS22990 is enabled.

6 Test Configurations

6.1 On-Resistance (R_{ON}) Test Setup

Figure 4 shows the typical setup for measuring on-resistance. The voltage drop across the switch is measured using the sense connections and this can be divided by the load current to calculate the R_{ON} resistance.

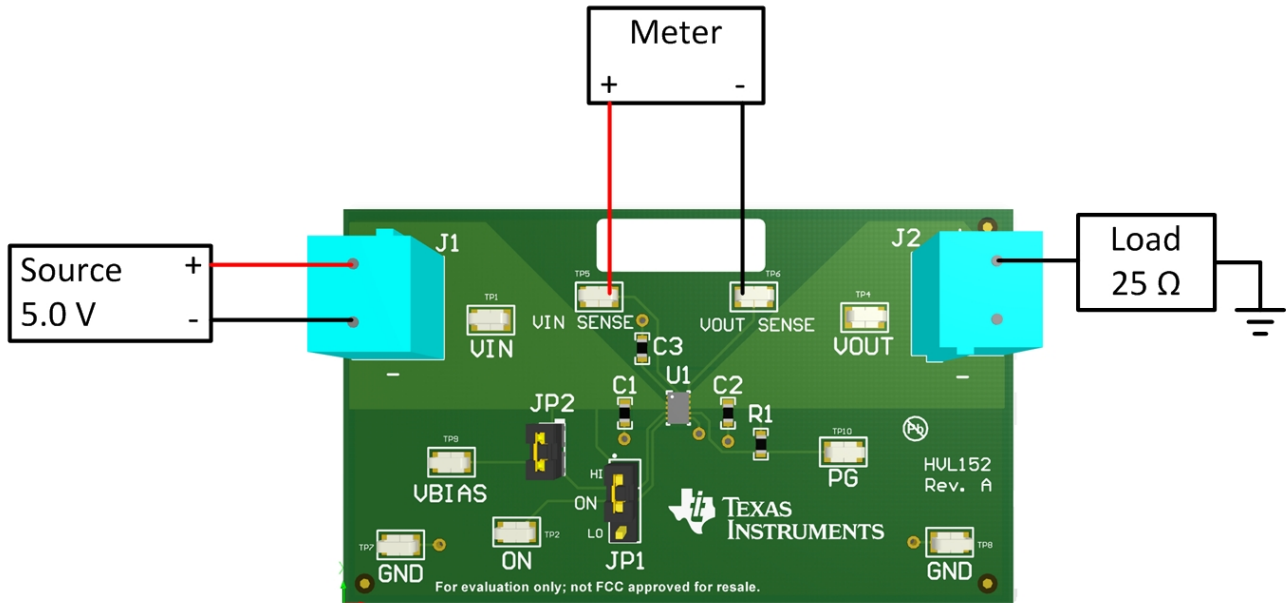

Figure 4. R_{ON} Test Setup

6.2 Rise Time Test Setup

Figure 5 shows the test setup for measuring the rise time of the TPS22990. Apply a square wave to the ON pin of the switch using a function generator and apply a voltage to the VIN terminal using a power supply. Observe the waveform at VOUT Sense (TP6) with an oscilloscope to measure the slew rate and rise time of the switch with a given input voltage. To vary the output voltage rise time, change the default 1000-pF CT capacitor (C3). For more information on the rise time variance with CT capacitor value, refer to the TPS22990 data sheet (SLVSDK1).

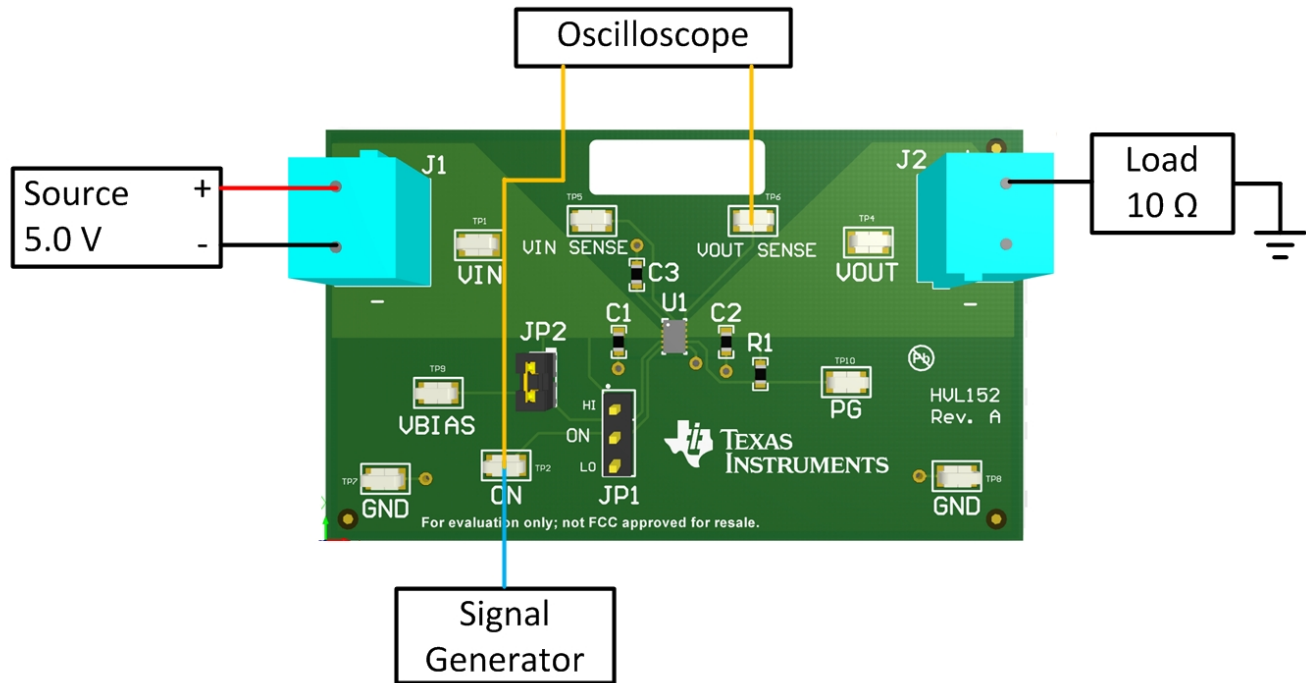

Figure 5. Rise Time Test Setup

6.3 V_{OUT} Rise Time Example

Figure 6 shows an example of a rise time measurement taken on the TPS22990 EVM.

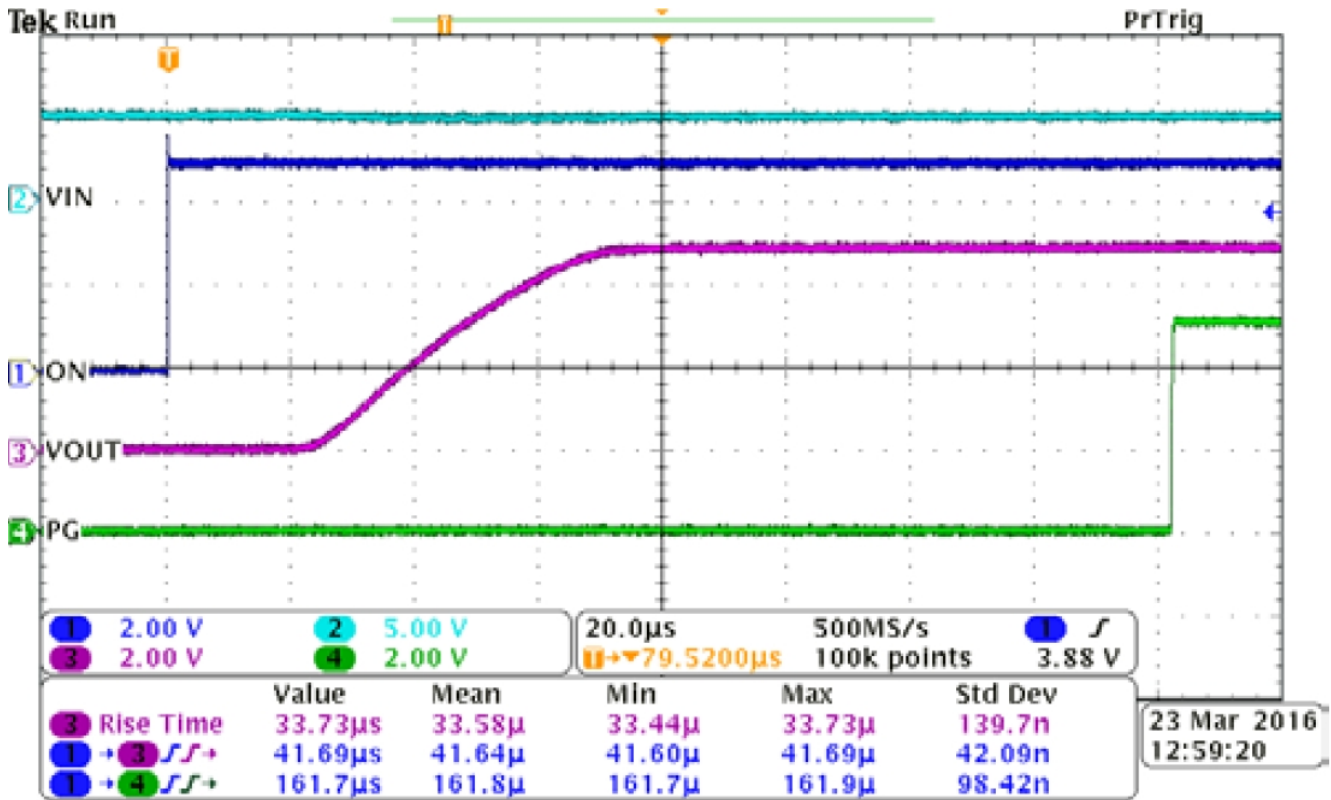

Figure 6. TPS22990 V_{OUT} t_R Example ($V_{IN} = 5\text{ V}$, $V_{BIAS} = 5\text{ V}$, $C_T = 0\text{ pF}$, $R_L = 10\ \Omega$)

7 Bill of Materials (BOM)

Table 2 lists the EVM BOM.

Table 2. Bill of Materials TPS22990 EVM

Qty	Designator	Value	Description	Package Reference	Manufacturer	Part Number
1	IPCB		Printed Circuit Board		Any	HVL140
1	C1	1uF	CAP, CERM, 1 μ F, 16 V, +/- 10%, X5R, 0603	0603	TDK	C1608X5R1C105K
1	C2	0.1uF	CAP, CERM, 0.1 μ F, 25 V, +/- 10%, X7R, 0603	0603	TDK	C1608X7R1E104K
1	C3	1000pF	CAP, CERM, 1000 pF, 50 V, +/- 10%, X7R, 0603	0603	Kemet	C0603C102K5RACTU
2	J1, J2	PEC02S AAN	TERMINAL BLOCK 5.08MM VERT 2POS, TH	TERM_BLK, 2pos, 5.08mm	On-Shore Technology	ED120/2DS
1	JP1		Header, 100mil, 3x1, Gold, TH	3x1 Header	Samtec	TSW-103-07-G-S
1	JP2		Header, 100mil, 2x1, Gold, TH	Header, 2.54mm, 2x1, TH	Samtec	HMTSW-102-07-G-S-240
1	R1	10k	RES, 10 k, 5%, 0.1 W, 0603	0603	Vishay-Dale	CRCW0603300RJNEA
1	LBL1		Thermal Transfer Printable Labels, 0.650" W x 0.200" H - 10,000 per roll	PCB Label 0.650"H x 0.200"W	Brady	THT-14-423-10
2	SH-J1, SH-J2	1x2	Shunt, 100mil, Gold plated, Black	Shunt	3M, Alternate: Samtec	969102-0000-DA, Alternate: SNT-100-BK-G
9	TP1, TP2, TP4, TP5, TP6, TP7, TP8, TP9, TP10		Test Point, Miniature, SMT	Test Point, Miniature, SMT	Keystone	5019
1	U1		5.5 V, 10 A, 4.4 mW On-Resistance Load Switch, DML0010A	DML0010A	Texas Instruments	TPS22990xDML
0	FID1, FID2, FID3		Fiducial mark. There is nothing to buy or mount.	Fiducial	N/A	N/A

IMPORTANT NOTICE

Texas Instruments Incorporated and its subsidiaries (TI) reserve the right to make corrections, enhancements, improvements and other changes to its semiconductor products and services per JESD46, latest issue, and to discontinue any product or service per JESD48, latest issue. Buyers should obtain the latest relevant information before placing orders and should verify that such information is current and complete. All semiconductor products (also referred to herein as "components") are sold subject to TI's terms and conditions of sale supplied at the time of order acknowledgment.

TI warrants performance of its components to the specifications applicable at the time of sale, in accordance with the warranty in TI's terms and conditions of sale of semiconductor products. Testing and other quality control techniques are used to the extent TI deems necessary to support this warranty. Except where mandated by applicable law, testing of all parameters of each component is not necessarily performed.

TI assumes no liability for applications assistance or the design of Buyers' products. Buyers are responsible for their products and applications using TI components. To minimize the risks associated with Buyers' products and applications, Buyers should provide adequate design and operating safeguards.

TI does not warrant or represent that any license, either express or implied, is granted under any patent right, copyright, mask work right, or other intellectual property right relating to any combination, machine, or process in which TI components or services are used. Information published by TI regarding third-party products or services does not constitute a license to use such products or services or a warranty or endorsement thereof. Use of such information may require a license from a third party under the patents or other intellectual property of the third party, or a license from TI under the patents or other intellectual property of TI.

Reproduction of significant portions of TI information in TI data books or data sheets is permissible only if reproduction is without alteration and is accompanied by all associated warranties, conditions, limitations, and notices. TI is not responsible or liable for such altered documentation. Information of third parties may be subject to additional restrictions.

Resale of TI components or services with statements different from or beyond the parameters stated by TI for that component or service voids all express and any implied warranties for the associated TI component or service and is an unfair and deceptive business practice. TI is not responsible or liable for any such statements.

Buyer acknowledges and agrees that it is solely responsible for compliance with all legal, regulatory and safety-related requirements concerning its products, and any use of TI components in its applications, notwithstanding any applications-related information or support that may be provided by TI. Buyer represents and agrees that it has all the necessary expertise to create and implement safeguards which anticipate dangerous consequences of failures, monitor failures and their consequences, lessen the likelihood of failures that might cause harm and take appropriate remedial actions. Buyer will fully indemnify TI and its representatives against any damages arising out of the use of any TI components in safety-critical applications.

In some cases, TI components may be promoted specifically to facilitate safety-related applications. With such components, TI's goal is to help enable customers to design and create their own end-product solutions that meet applicable functional safety standards and requirements. Nonetheless, such components are subject to these terms.

No TI components are authorized for use in FDA Class III (or similar life-critical medical equipment) unless authorized officers of the parties have executed a special agreement specifically governing such use.

Only those TI components which TI has specifically designated as military grade or "enhanced plastic" are designed and intended for use in military/aerospace applications or environments. Buyer acknowledges and agrees that any military or aerospace use of TI components which have **not** been so designated is solely at the Buyer's risk, and that Buyer is solely responsible for compliance with all legal and regulatory requirements in connection with such use.

TI has specifically designated certain components as meeting ISO/TS16949 requirements, mainly for automotive use. In any case of use of non-designated products, TI will not be responsible for any failure to meet ISO/TS16949.

Products

Audio	www.ti.com/audio
Amplifiers	amplifier.ti.com
Data Converters	dataconverter.ti.com
DLP® Products	www.dlp.com
DSP	dsp.ti.com
Clocks and Timers	www.ti.com/clocks
Interface	interface.ti.com
Logic	logic.ti.com
Power Mgmt	power.ti.com
Microcontrollers	microcontroller.ti.com
RFID	www.ti-rfid.com
OMAP Applications Processors	www.ti.com/omap
Wireless Connectivity	www.ti.com/wirelessconnectivity

Applications

Automotive and Transportation	www.ti.com/automotive
Communications and Telecom	www.ti.com/communications
Computers and Peripherals	www.ti.com/computers
Consumer Electronics	www.ti.com/consumer-apps
Energy and Lighting	www.ti.com/energy
Industrial	www.ti.com/industrial
Medical	www.ti.com/medical
Security	www.ti.com/security
Space, Avionics and Defense	www.ti.com/space-avionics-defense
Video and Imaging	www.ti.com/video

TI E2E Community

e2e.ti.com