

TLC3574, TLC3578, TLC2574, TLC2578

5-V ANALOG, 3-/5-V DIGITAL, 14-/12-BIT, 200-KSPS, 4-/8-CHANNEL SERIAL ANALOG-TO-DIGITAL CONVERTERS WITH ± 10 -V INPUTS

SLAS262C – OCTOBER 2000 – REVISED MAY 2003

- 14-Bit Resolution for TLC3574/78, 12-Bit for TLC2574/2578
- Maximum Throughput 200-KSPS
- Multiple Analog Inputs:
 - 8 Single-Ended Channels for TLC3578/2578
 - 4 Single-Ended Channels for TLC3574/2574
- Analog Input Range: ± 10 V
- Pseudodifferential Analog Inputs
- SPI/DSP-Compatible Serial Interfaces With SCLK up to 25-MHz
- Built-In Conversion Clock and 8x FIFO
- Single 5-V Analog Supply; 3-/5-V Digital Supply
- Low-Power
 - 5.8 mA in Normal Operation
 - 20 μ A in Power Down
- Programmable Autochannel Sweep and Repeat
- Hardware-Controlled, Programmable Sampling Period
- Hardware Default Configuration
- INL: TLC3574/78: ± 1 LSB;
TLC2574/78: ± 0.5 LSB
- DNL: TLC3574/78: ± 0.5 LSB;
TLC2574/78: ± 0.5 LSB
- SINAD: TLC3574/78: 79 dB;
TLC2574/78: 72 dB
- THD: TLC3574/78: -82 dB;
TLC2574/78: -82 dB

TLC3578, TLC2578
DW OR PW PACKAGE
(TOP VIEW)

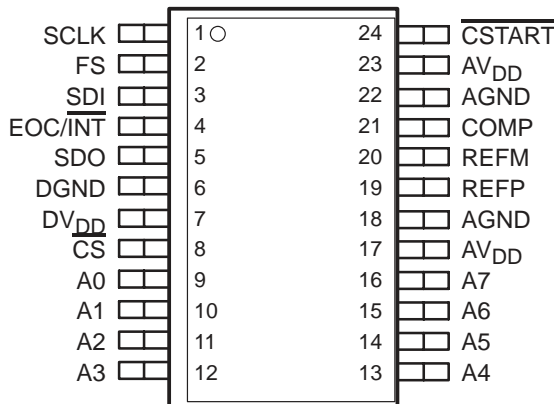

TLC3574, TLC2574
DW, N, OR PW PACKAGE
(TOP VIEW)

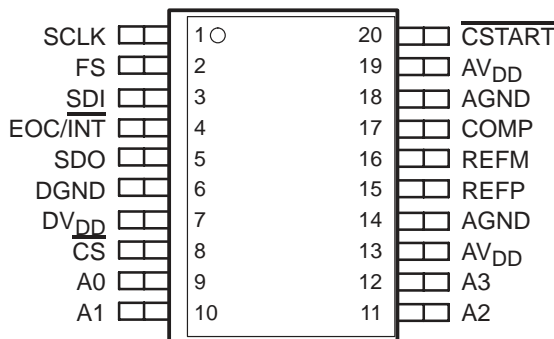

description

The TLC3574, TLC3578, TLC2574, and TLC2578 are a family of high-performance, low-power, CMOS analog-to-digital converters (ADC). TLC3574/78 is a 14-bit ADC; TLC2574/78 is a 12-bit ADC. All parts operate from single 5-V analog power supply and 3-V to 5-V digital supply. The serial interface consists of four digital input [chip select (\overline{CS}), frame sync (FS), serial input-output clock (SCLK), serial data input (SDI)], and a 3-state serial data output (SDO). \overline{CS} (works as \overline{SS} , slave select), SDI, SDO and SCLK form an SPI interface. FS, SDI, SDO, and SCLK form DSP interface. The frame sync signal (FS) indicates the start of a serial data frame being transferred. When multiple converters connect to one serial port of a DSP, \overline{CS} works as the chip select to allow the host DSP to access the individual converter. \overline{CS} can be tied to ground if only one converter is used. FS must be tied to DV_{DD} if it is not used (such as in an SPI interface). When SDI is tied to DV_{DD} , the device is set in hardware default mode after power on and no software configuration is required. In the simplest case, only three wires (SDO, SCLK, and \overline{CS} or FS) are needed to interface with the host.



Please be aware that an important notice concerning availability, standard warranty, and use in critical applications of Texas Instruments semiconductor products and disclaimers thereto appears at the end of this data sheet.

PRODUCTION DATA information is current as of publication date. Products conform to specifications per the terms of Texas Instruments standard warranty. Production processing does not necessarily include testing of all parameters.

 **TEXAS
INSTRUMENTS**

POST OFFICE BOX 655303 • DALLAS, TEXAS 75265

Copyright © 2000 – 2003, Texas Instruments Incorporated

TLC3574, TLC3578, TLC2574, TLC2578

5-V ANALOG, 3-/5-V DIGITAL, 14-/12-BIT, 200-KSPS, 4-/8-CHANNEL SERIAL ANALOG-TO-DIGITAL CONVERTERS WITH ± 10 -V INPUTS

SLAS262C – OCTOBER 2000 – REVISED MAY 2003

description (continued)

In addition to being a high-speed ADC with versatile control capability, these devices have an on-chip analog multiplexer (MUX) that can select any analog input or one of three self-test voltages. The sample-and-hold function is automatically started after the fourth SCLK (normal sampling) or can be controlled by a special pin, $\overline{\text{CSTART}}$, to extend the sampling period (extended sampling). The normal sampling period can also be programmed as short sampling (12 SCLKs) or long sampling (44 SCLKs) to accommodate the faster SCLK operation popular among high-performance signal processors. The TLC3574/78 and TLC2574/78 are designed to operate with low-power consumption. The power saving feature is further enhanced with autopower-down mode and programmable conversion speeds. The conversion clock (internal OSC) is built in. The converter can also use an external SCLK as the conversion clock for maximum flexibility. The TLC3574/78 and TLC2574/78 are specified with bipolar input and a full scale range of ± 10 V.

AVAILABLE OPTIONS

TA	PACKAGED DEVICES				
	20-TSSOP (PW)	20-SOIC (DW)	20-PDIP (N)	24-SOIC (DW)	24-TSSOP (PW)
-40°C to 85°C	TLC2574IPW	TLC2574IDW	TLC2574IN	TLC2578IDW	TLC2578IPW
	TLC3574IPW	TLC3574IDW	TLC3574IN	TLC3578IDW	TLC3578IPW

functional block diagram

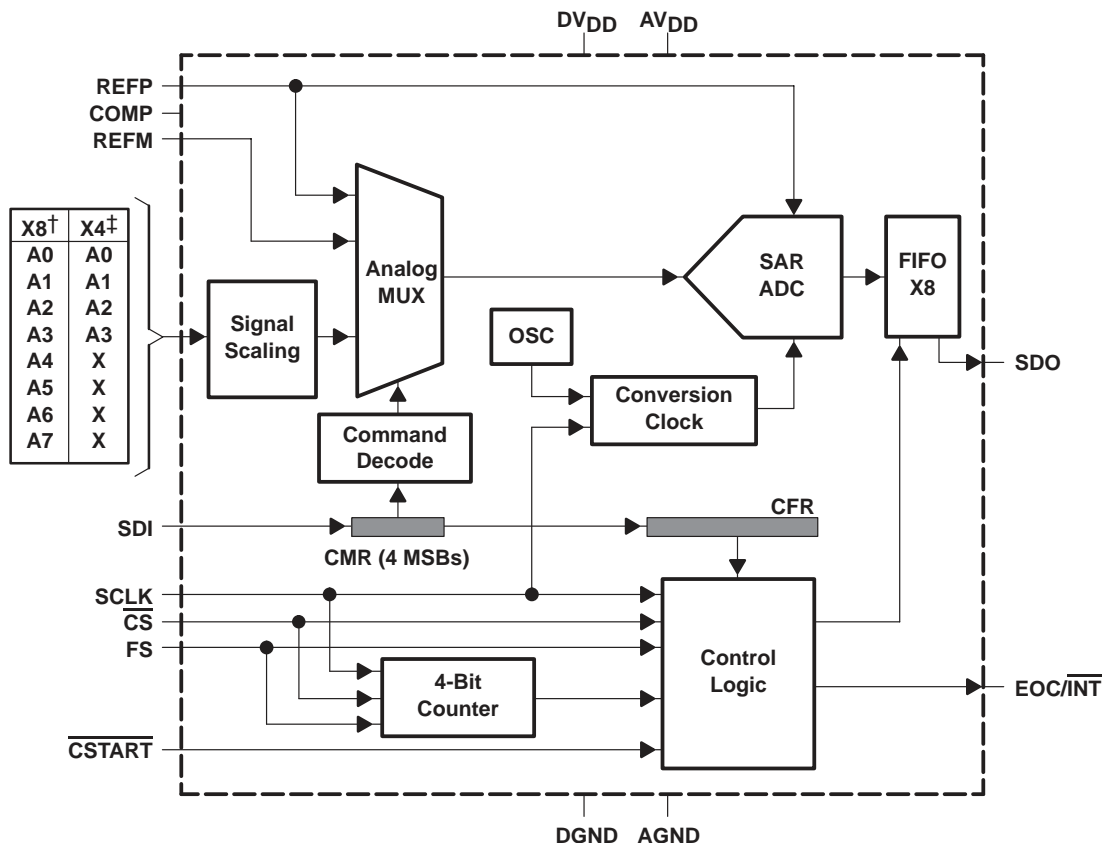

† TLC3578, TLC2578

‡ TLC3574, TLC2574

NOTE: 4-Bit counter counts the CLOCK, SCLK. The CLOCK is gated in by $\overline{\text{CS}}$ falling edge if $\overline{\text{CS}}$ initiates the conversion operation cycle, or gated in by the rising edge of FS if FS initiates the operation cycle. SCLK is disabled for serial interface when $\overline{\text{CS}}$ is high.



TLC3574, TLC3578, TLC2574, TLC2578
5-V ANALOG, 3-/5-V DIGITAL, 14-/12-BIT, 200-KSPS, 4-/8-CHANNEL
SERIAL ANALOG-TO-DIGITAL CONVERTERS WITH ± 10 -V INPUTS

SLAS262C – OCTOBER 2000 – REVISED MAY 2003

equivalent input circuit

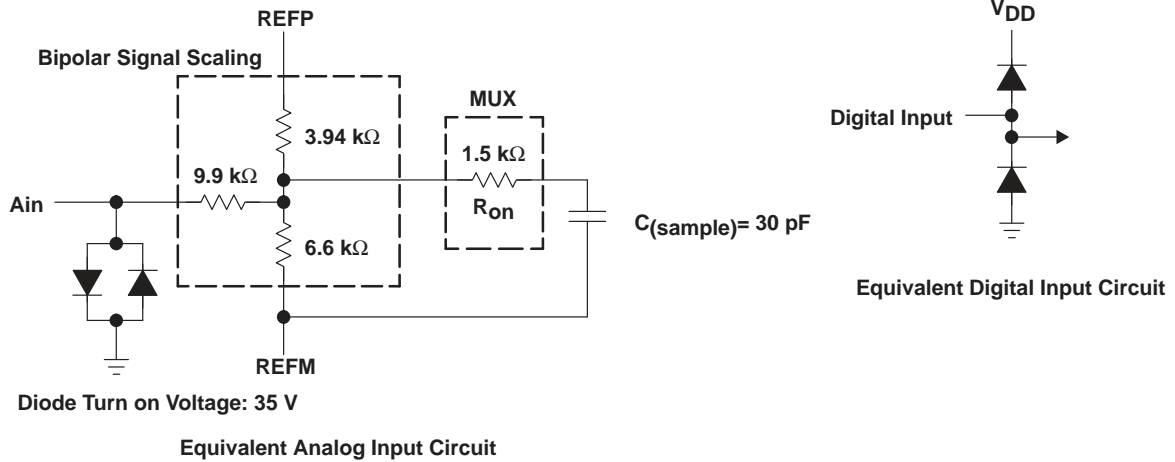

Terminal Functions

TERMINAL		NO.		I/O	DESCRIPTION
		TLC3574	TLC3578		
NAME		TLC2574	TLC2578		
A0	A0	9	9	I	Analog signal inputs. Analog input signals applied to these terminals are internally multiplexed. The driving source impedance should be less than or equal to 25 Ω for normal sampling. For larger source impedance, use the external hardware conversion start signal \overline{CSTART} (the low time of \overline{CSTART} controls the sampling period) or reduce the frequency of SCLK to increase the sampling time.
A1	A1	10	10		
A2	A2	11	11		
A3	A3	12	12		
	A4		13		
	A5		14		
	A6		15		
	A7		16		
AGND		14, 18	18, 22	I	Analog ground return for the internal circuitry. Unless otherwise noted, all analog voltage measurements are with respect to AGND.
AV_{DD}		13, 19	17, 23	I	Analog supply voltage
COMP		17	21	I	Internal compensation pin. Install compensation capacitors 0.1 μ F between this pin and AGND.
\overline{CS}		8	8	I	Chip select. When \overline{CS} is high, SDO is in high-impedance state, SDI is ignored, and SCLK is disabled to clock data, but works as conversion clock source if programmed. The falling edge of \overline{CS} input resets the internal 4-bit counter, enables SDI and SCLK, and removes SDO from high-impedance state. If FS is high at \overline{CS} falling edge, \overline{CS} falling edge initiates the operation cycle. \overline{CS} works as slave select (\overline{SS}) to provide an SPI interface. If FS is low at \overline{CS} falling edge, FS rising edge initiates the operation cycle. \overline{CS} can be used as chip select to allow host to access the individual converter.
\overline{CSTART}		20	24	I	External sampling trigger signal, which initiates the sampling from a selected analog input channel when the device works in extended sampling mode (asynchronous sampling). A high-to-low transition starts the sampling of the analog input signal. A low-to-high transition puts the S/H in hold mode and starts the conversion. The low time of the \overline{CSTART} signal controls the sampling period. \overline{CSTART} signal must stay low long enough for proper sampling. \overline{CSTART} must stay high long enough after the low-to-high transition for the conversion to finish maturely. The activation of \overline{CSTART} is independent of SCLK and the level of \overline{CS} and FS. However, the first \overline{CSTART} cannot be issued before the rising edge of the eleventh SCLK. Tie this pin to DV_{DD} if not used.
DGND		6	6	I	Digital ground return for the internal circuitry
DV_{DD}		7	7	I	Digital supply voltage

TLC3574, TLC3578, TLC2574, TLC2578
5-V ANALOG, 3-/5-V DIGITAL, 14-/12-BIT, 200-KSPS, 4-/8-CHANNEL
SERIAL ANALOG-TO-DIGITAL CONVERTERS WITH ±10-V INPUTS

SLAS262C – OCTOBER 2000 – REVISED MAY 2003

Terminal Functions (Continued)

TERMINAL			I/O	DESCRIPTION
NAME	NO.			
	TLC3574 TLC2574	TLC3578 TLC2578		
EOC($\overline{\text{INT}}$)	4	4	O	End of conversion (EOC) or interrupt to host processor ($\overline{\text{INT}}$) EOC: used in conversion mode 00 only. EOC goes from high to low at the end of the sampling and remains low until the conversion is complete and data is ready. $\overline{\text{INT}}$: Interrupt to the host processor. The falling edge of $\overline{\text{INT}}$ indicates data is ready for output. $\overline{\text{INT}}$ is cleared by the following $\overline{\text{CS}}\downarrow$, $\text{FS}\uparrow$, or $\text{CSTART}\downarrow$.
FS	2	2	I	Frame sync input from DSP. The rising edge of FS indicates the start of a serial data frame being transferred (coming into or being sent out of the device). If FS is low at the falling edge of $\overline{\text{CS}}$, the rising edge of FS initiates the operation cycle, resets the internal 4-bit counter, and enables SDI, SDO, and SCLK. Tie this pin to DV _{DD} if FS is not used to initiate the operation cycle.
REFM	16	20	I	External low reference input. Connect REFM to AGND.
REFP	15	19	I	External positive reference input. The range of maximum input voltage is determined by the difference between the voltage applied to this terminal and to the REFM terminal. Always install decoupling capacitors (10 μF in parallel with 0.1 μF) between REFP and REFM.
SCLK	1	1	I	Serial clock input from the host processor to clock in the input from SDI and clock out the output via SDO. It can also be used as the conversion clock source when the external conversion clock is selected (see Table 2). When $\overline{\text{CS}}$ is low, SCLK is enabled. When $\overline{\text{CS}}$ is high, SCLK is disabled for the data transfer, but can still work as the conversion clock source.
SDI	3	3	I	Serial data input. The first 4 MSBs, ID[15:12], are decoded as one 4-bit command. All trailing bits, except for the WRITE CFR command, are filled with zeros. The WRITE CFR command requires additional 12-bit data. The MSB of input data, ID(15), is latched at the first falling edge of SCLK following $\overline{\text{FS}}$ falling edge if $\overline{\text{FS}}$ starts the operation, or latched at the falling edge of first SCLK following $\overline{\text{CS}}$ falling edge when $\overline{\text{CS}}$ initiates the operation. The remaining input data (if any) is shifted in on the rising edge of SCLK and latched on the falling edge of SCLK. The input via SDI is ignored after the 4-bit counter counts to 16 (clock edges) or a low-to-high transition of $\overline{\text{CS}}$, whichever happens first. Refer to the timing specification for the timing requirements. Tie SDI to DV _{DD} if using hardware default mode (refer to Device Initialization).
SDO	5	5	O	The 3-state serial output for the A/D conversion result. All data bits are shifted out through SDO. SDO is in the high-impedance state when $\overline{\text{CS}}$ is high. SDO is released after a $\overline{\text{CS}}$ falling edge. The output format is MSB (OD15) first. When FS initiates the operation, the MSB of output via SDO, OD(15), is valid before the first falling edge of SCLK following the falling edge of FS. When $\overline{\text{CS}}$ initiates the operation, the MSB, OD(15), is valid before the first falling edge of SCLK following the $\overline{\text{CS}}$ falling edge. The remaining data bits (if any) are shifted out on the rising edge of SCLK and are valid before the falling edge of SCLK. Refer to the timing specification for the details. In select/conversion operation, the first 14 bits (for TLC3574/78) or the first 12 bits (for TLC2574/78) are the results from the previous conversion (data). In a READ FIFO operation, this data is from FIFO. In both cases, the last two bits (for TLC3574/78) or the last four bits (for TLC2574/78) are don't care. In a WRITE operation, the output from SDO must be ignored. SDO goes into high-impedance state at the 16th falling edge of SCLK after the operation cycle is initiated. SDO is in high-impedance state during conversions in modes 01, 10, and 11.



TLC3574, TLC3578, TLC2574, TLC2578
5-V ANALOG, 3-/5-V DIGITAL, 14-/12-BIT, 200-KSPS, 4-/8-CHANNEL
SERIAL ANALOG-TO-DIGITAL CONVERTERS WITH ± 10 -V INPUTS

SLAS262C – OCTOBER 2000 – REVISED MAY 2003

absolute maximum ratings over operating free-air temperature (unless otherwise noted)†

Supply voltage, GND to AV _{DD} and DV _{DD}	–0.3 V to 6.5 V
Analog input voltage range	–17 V to 17 V
Analog input current	100 mA MAX
Reference input voltage	AV _{DD} + 0.3 V
Digital input voltage range	–0.3 V to DV _{DD} + 0.3 V
Operating virtual junction temperature range, T _J	–40°C to 150°C
Operating free-air temperature range, T _A	–40°C to 85°C
Storage temperature range, T _{stg}	–65°C to 150°C
Lead temperature 1,6 mm (1.16 inch) from case for 10 seconds	260°C

† Stresses beyond those listed under “absolute maximum ratings” may cause permanent damage to the device. These are stress ratings only, and functional operation of the device at these or any other conditions beyond those indicated under *electrical characteristics and timing characteristics* is not implied. Exposure to absolute-maximum-rated conditions for extended periods may affect device reliability.

general electrical characteristics over recommended operating free-air temperature range, single-ended input, normal long sampling, 200 KSPS, AV_{DD} = 5 V, V_{REFP} = 4 V, V_{REFM} = 0 V, SCLK frequency = 25 MHz, fixed channel at CONV mode 00, analog input signal source resistance = 25 Ω (unless otherwise noted)

PARAMETER		TEST CONDITIONS		MIN	TYP†	MAX	UNIT	
Digital Input								
V _{IH}	High-level digital input voltage	DV _{DD} = 5 V		3.8			V	
		DV _{DD} = 3 V		2.1				
V _{IL}	Low-level digital input voltage	DV _{DD} = 5 V				0.8	V	
		DV _{DD} = 3 V				0.6		
I _{IH}	High-level digital input current	V _I = DV _{DD}		0.005		2.5	μ A	
I _{IL}	Low-level digital input current	V _I = DGND		–2.5	–0.005		μ A	
Input capacitance				20		25	pF	
Digital Output								
V _{OH}	High-level digital output at 30 pF load	I _O = –0.2 mA	DV _{DD} = 5 V		4.2		V	
			DV _{DD} = 3 V		2.4			
V _{OL}	Low-level digital output at 30 pF load	DV _{DD} = 5 V	I _O = 0.8 mA				0.4	
			I _O = 50 μ A				0.1	
		DV _{DD} = 3 V	I _O = 0.8 mA				0.4	
			I _O = 50 μ A				0.1	
I _{OZ}	Off-state output current (high-impedance state)	V _O = DV _{DD}	CS = DV _{DD}		0.02		μ A	
		V _O = DGND			–1 0.02			
Power Supply								
AV _{DD}	Supply voltage				4.75	5	5.5	V
DV _{DD}					2.7	5	5.5	V
I _{CC}	Power supply current	AV _{DD} current AI _{CC}	Conversion clock is internal OSC, AV _{DD} = 5.5 V – 4.5 V, CS = DGND, Excluding bipolar input biasing current		4.2		5	mA
		DV _{DD} current DI _{CC}			1.6		2.0	
I _{CC} (autopwr _{dn})	Autopower-down power supply current	For all digital inputs = DV _{DD} or DGND, AV _{DD} = 5.5 V, Excluding bipolar input biasing current, external reference		SCLK OFF	20		μ A	
				SCLK ON	175 230			
Operating temperature				–40		85	°C	

† All typical values are at T_A = 25°C.



TLC3574, TLC3578, TLC2574, TLC2578
5-V ANALOG, 3-/5-V DIGITAL, 14-/12-BIT, 200-KSPS, 4-/8-CHANNEL
SERIAL ANALOG-TO-DIGITAL CONVERTERS WITH ± 10 -V INPUTS

SLAS262C – OCTOBER 2000 – REVISED MAY 2003

general electrical characteristics over recommended operating free-air temperature range, single-ended input, normal long sampling, 200 KSPS, $V_{DD} = 5$ V, $V_{REFP} = 4$ V, $V_{REFM} = 0$ V, SCLK frequency = 25 MHz, fixed channel at CONV mode 00, analog input signal source resistance = 25 Ω (unless otherwise noted)

TLC3574/78 and TLC2574/78

PARAMETER	TEST CONDITIONS	MIN	TYP†	MAX	UNIT
Resolution		14			bits
Analog Input					
Voltage range		-10		10	V
Selected analog input channel bias current	Selected channel at 10 V		0.8	1.6	mA
	Selected channel at -10 V	-1.6	-1.2		
Impedance			10		k Ω
Capacitance			30		pF
Reference					
V_{REFP} Positive reference voltage		3.96	4	4.04	V
V_{REFM} Negative reference voltage		0	AGND		V
Input impedance	No conversion ($V_{DD} = 5$ V, $\overline{CS} = DV_{DD}$, SCLK=DGND)	100			M Ω
	Normal long sampling ($V_{DD} = 5$ V, $\overline{CS} = DGND$, SCLK = 25 MHz, External conversion clock)	8.3	12.5		k Ω
Reference current	No conversion ($V_{DD} = 5$ V, SCLK = DGND, $\overline{CS} = DV_{DD}$)			1.5	μ A
	Normal long sampling ($V_{DD} = 5$ V, $\overline{CS} = DGND$, External conversion clock, SCLK = 25 MHz, $V_{REF} = 5$ V)		0.4	0.6	mA
Internal oscillation frequency	$DV_{DD} = 2.7$ V – 5.5 V	6.5			MHz
$t_{(conv)}$ Conversion time	Internal OSC, 6.5 MHz minimum	TLC3574/78		2.785	μ S
		TLC2574/78		2.015	
	Conversion clock is external source, SCLK = 25 MHz (see Note 1)	TLC3574/78		2.895	
		TLC2574/78		2.095	
Acquisition time	Normal short sampling		1.2		μ S
Throughput rate (see Note 2)	Normal long sampling, fixed channel in mode 00 or 01	200			KSPS

† All typical values are at $T_A = 25^\circ\text{C}$.

- NOTES: 1. Conversion time $t_{(conv)}$ is $(18 \times 4 \times \text{SCLK}) + 15$ ns for TLC3574/78. Conversion time is $(13 \times 4 \times \text{SCLK}) + 15$ ns for TLC2574/78.
 2. This is for a fixed channel in conversion mode 00 or 01. When switching the channels, additional multiplexer setting time is required to overcome the memory effect of the charge redistribution DAC.



TLC3574, TLC3578, TLC2574, TLC2578
5-V ANALOG, 3-/5-V DIGITAL, 14-/12-BIT, 200-KSPS, 4-/8-CHANNEL
SERIAL ANALOG-TO-DIGITAL CONVERTERS WITH ± 10 -V INPUTS

SLAS262C – OCTOBER 2000 – REVISED MAY 2003

AC/DC performance over recommended operating free-air temperature range, single-ended input, normal long sampling, 200 KSPS, $V_{DD} = 5$ V, $V_{REFP} = 4$ V, $V_{REFM} = 0$ V, SCLK frequency = 25 MHz, fixed channel at CONV mode 00, analog input signal source resistance = 25 Ω (unless otherwise noted)

TLC3574/78 DW and PW package device AC/DC performance

PARAMETER		TEST CONDITIONS	MIN	TYP†	MAX	UNIT
DC Accuracy—Normal Long Sampling						
E_L	Integral linearity error	See Note 3	-1.5	± 1	1.5	LSB
E_D	Differential linearity error		-1	± 0.5	1	LSB
E_O	Bipolar zero error	See Note 4	-0.30	± 0.08	0.36	%FS
$E_{FS(+)}$	Positive full scale error	See Note 4	-0.55	± 0.04	0.61	%FS
$E_{FS(-)}$	Negative full scale error	See Note 4	-0.30	± 0.13	0.79	%FS
DC Accuracy—Normal Short Sampling						
E_L	Integral linearity error	See Note 3		± 1		LSB
E_D	Differential linearity error			± 0.5		LSB
E_O	Bipolar zero error	See Note 4		± 0.08		%FS
$E_{FS(+)}$	Positive full scale error	See Note 4		± 0.04		%FS
$E_{FS(-)}$	Negative full scale error	See Note 4		± 0.13		%FS
AC Accuracy (see Note 3)—Normal Long Sampling						
SINAD	Signal-to-noise ratio + distortion	$f_i = 20$ kHz	76	79		dB
		$f_i = 100$ kHz		75		
THD	Total harmonic distortion	$f_i = 20$ kHz		-82	-77	dB
		$f_i = 100$ kHz		-78		
SNR	Signal-to-noise ratio	$f_i = 20$ kHz	78	80		dB
		$f_i = 100$ kHz		78		
ENOB	Effective number of bits	$f_i = 20$ kHz	12.3	12.8		Bits
		$f_i = 100$ kHz		12.2		
SFDR	Spurious free dynamic range	$f_i = 20$ kHz	78	84		dB
		$f_i = 100$ kHz		79		
	Channel-to-channel isolation	Fixed channel in conversion mode 00, $f_i = 35$ kHz, See Notes 2 and 5		81		dB
	Analog input bandwidth	Full power bandwidth, -3 dB		1		MHz
		Full power bandwidth, -1 dB		700		kHz

† All typical values are at $T_A = 25^\circ\text{C}$.

- NOTES:
- This is for a fixed channel in conversion mode 00 or 01. When switching the channels, additional multiplexer setting time is required to overcome the memory effect of the charge redistribution DAC.
 - Linear error is the maximum deviation from the best fit straight line through the A/D transfer characteristics.
 - Bipolar zero error is the difference between 1000000000000 and the converted output for zero input voltage; positive full-scale error is the difference between 1111111111111 and the converted output for positive full-scale input voltage (10 V); negative full-scale error is the difference between 0000000000000 and the converted output for negative full-scale input voltage (-10 V).
 - It is measured by applying a full-scale of 35 kHz signal to other channels and determining how much the signal is attenuated in the channel of interest. The converter samples this examined channel continuously. The channel-to-channel isolation is degraded if the converter samples different channels alternately.



TLC3574, TLC3578, TLC2574, TLC2578
5-V ANALOG, 3-/5-V DIGITAL, 14-/12-BIT, 200-KSPS, 4-/8-CHANNEL
SERIAL ANALOG-TO-DIGITAL CONVERTERS WITH ± 10 -V INPUTS

SLAS262C – OCTOBER 2000 – REVISED MAY 2003

TLC3574/78 DW and PW package device AC/DC performance (continued)

PARAMETER		TEST CONDITIONS	MIN	TYP†	MAX	UNIT
AC Accuracy—Normal Short Sampling						
SINAD	Signal-to-noise ratio + distortion	$f_i = 20$ kHz		79		dB
		$f_i = 100$ kHz		75		
THD	Total harmonic distortion	$f_i = 20$ kHz		-82		dB
		$f_i = 100$ kHz		-78		
SNR	Signal-to-noise ratio	$f_i = 20$ kHz		80		dB
		$f_i = 100$ kHz		78		
ENOB	Effective number of bits	$f_i = 20$ kHz		12.8		Bits
		$f_i = 100$ kHz		12.2		
SFDR	Spurious free dynamic range	$f_i = 20$ kHz		84		dB
		$f_i = 100$ kHz		79		
Channel-to-channel isolation		Fixed channel in conversion mode 00, $f_i = 35$ kHz, See Notes 2 and 5		81		dB
Analog input bandwidth		Full power bandwidth, -3 dB		1		MHz
		Full power bandwidth, -1 dB		700		kHz

† All typical values are at $T_A = 25^\circ\text{C}$.

NOTES: 2. This is for a fixed channel in conversion mode 00 or 01. When switching the channels, additional multiplexer setting time is required to overcome the memory effect of the charge redistribution DAC.

5. It is measured by applying a full-scale of 35 kHz signal to other channels and determining how much the signal is attenuated in the channel of interest. The converter samples this examined channel continuously. The channel-to-channel isolation is degraded if the converter samples different channels alternately.



TLC3574, TLC3578, TLC2574, TLC2578
5-V ANALOG, 3-/5-V DIGITAL, 14-/12-BIT, 200-KSPS, 4-/8-CHANNEL
SERIAL ANALOG-TO-DIGITAL CONVERTERS WITH ± 10 -V INPUTS

SLAS262C – OCTOBER 2000 – REVISED MAY 2003

TLC3574I N package device AC/DC performance

PARAMETER		TEST CONDITIONS	MIN	TYP†	MAX	UNIT
DC Accuracy—Normal Long Sampling						
E_L	Integral linearity error	See Note 3	-1.5	± 1	1.5	LSB
E_D	Differential linearity error		-1	± 0.8	1.5	LSB
E_O	Bipolar zero error	See Note 4	-0.30	± 0.08	0.36	%FS
$E_{FS(+)}$	Positive full scale error	See Note 4	-0.55	± 0.04	0.61	%FS
$E_{FS(-)}$	Negative full scale error	See Note 4	-0.30	± 0.13	0.79	%FS
DC Accuracy—Normal Short Sampling						
E_L	Integral linearity error	See Note 3		± 1.8		LSB
E_D	Differential linearity error			± 0.8		LSB
E_O	Bipolar zero error	See Note 4		± 0.08		%FS
$E_{FS(+)}$	Positive full-scale error	See Note 4		± 0.04		%FS
$E_{FS(-)}$	Negative full-scale error	See Note 4		± 0.13		%FS
AC Accuracy (see Note 3)—Normal Long Sampling						
SINAD	Signal-to-noise ratio + distortion	$f_i = 20$ kHz	75	78		dB
		$f_i = 100$ kHz		75		
THD	Total harmonic distortion	$f_i = 20$ kHz		-82	-77	dB
		$f_i = 100$ kHz		-75		
SNR	Signal-to-noise ratio	$f_i = 20$ kHz	78	80		dB
		$f_i = 100$ kHz		76		
ENOB	Effective number of bits	$f_i = 20$ kHz	12.2	12.7		Bits
		$f_i = 100$ kHz		12.2		
SFDR	Spurious free dynamic range	$f_i = 20$ kHz	78	83		dB
		$f_i = 100$ kHz		75		
	Channel-to-channel isolation	Fixed channel in conversion mode 00, $f_i = 35$ kHz, See Notes 2 and 5		81		dB
	Analog input bandwidth	Full power bandwidth, -3 dB		1		MHz
		Full power bandwidth, -1 dB		700		kHz

† All typical values are at $T_A = 25^\circ\text{C}$.

- NOTES:
- This is for a fixed channel in conversion mode 00 or 01. When switching the channels, additional multiplexer setting time is required to overcome the memory effect of the charge redistribution DAC.
 - Linear error is the maximum deviation from the best fit straight line through the A/D transfer characteristics.
 - Bipolar zero error is the difference between 10000000000000 and the converted output for zero input voltage; positive full-scale error is the difference between 11111111111111 and the converted output for positive full-scale input voltage (10 V); negative full-scale error is the difference between 00000000000000 and the converted output for negative full-scale input voltage (-10 V).
 - It is measured by applying a full-scale of 35 kHz signal to other channels and determining how much the signal is attenuated in the channel of interest. The converter samples this examined channel continuously. The channel-to-channel isolation is degraded if the converter samples different channels alternately.



TLC3574, TLC3578, TLC2574, TLC2578
5-V ANALOG, 3-/5-V DIGITAL, 14-/12-BIT, 200-KSPS, 4-/8-CHANNEL
SERIAL ANALOG-TO-DIGITAL CONVERTERS WITH ± 10 -V INPUTS

SLAS262C – OCTOBER 2000 – REVISED MAY 2003

TLC3574I N package device AC/DC performance (continued)

PARAMETER		TEST CONDITIONS	MIN	TYP†	MAX	UNIT
AC Accuracy—Normal Short Sampling						
SINAD	Signal-to-noise ratio + distortion	$f_i = 20$ kHz		76		dB
		$f_i = 100$ kHz		70		
THD	Total harmonic distortion	$f_i = 20$ kHz		-81		dB
		$f_i = 100$ kHz		-74		
SNR	Signal-to-noise ratio	$f_i = 20$ kHz		78		dB
		$f_i = 100$ kHz		75		
ENOB	Effective number of bits	$f_i = 20$ kHz		12.3		Bits
		$f_i = 100$ kHz		11.3		
SFDR	Spurious free dynamic range	$f_i = 20$ kHz		83		dB
		$f_i = 100$ kHz		75		
	Channel-to-channel isolation	Fixed channel in conversion mode 00, $f_i = 35$ kHz, See Notes 2 and 5		81		dB
	Analog input bandwidth	Full power bandwidth, -3 dB		1		MHz
		Full power bandwidth, -1 dB		700		kHz

† All typical values are at $T_A = 25^\circ\text{C}$.

- NOTES:
2. This is for a fixed channel in conversion mode 00 or 01. When switching the channels, additional multiplexer setting time is required to overcome the memory effect of the charge redistribution DAC.
 5. It is measured by applying a full-scale of 35 kHz signal to other channels and determining how much the signal is attenuated in the channel of interest. The converter samples this examined channel continuously. The channel-to-channel isolation is degraded if the converter samples different channels alternately.



TLC3574, TLC3578, TLC2574, TLC2578
5-V ANALOG, 3-/5-V DIGITAL, 14-/12-BIT, 200-KSPS, 4-/8-CHANNEL
SERIAL ANALOG-TO-DIGITAL CONVERTERS WITH ± 10 -V INPUTS

SLAS262C – OCTOBER 2000 – REVISED MAY 2003

TLC2574/78 DW and PW package devices AC/DC performance

PARAMETER		TEST CONDITIONS	MIN	TYP†	MAX	UNIT
DC Accuracy						
E_L	Integral linearity error	See Note 6	-1	± 0.5	1	LSB
E_D	Differential linearity error		-1	± 0.5	1	LSB
E_O	Bipolar zero error	See Note 7	-0.30	± 0.08	0.36	%FS
$E_{FS(+)}$	Positive full scale error	See Note 7	-0.55	± 0.04	0.61	%FS
$E_{FS(-)}$	Negative full scale error	See Note 7	-0.30	± 0.13	0.79	%FS
AC Accuracy						
SINAD	Signal-to-noise ratio + distortion	$f_i = 20$ kHz	70	72		dB
		$f_i = 100$ kHz		70		
THD	Total harmonic distortion	$f_i = 20$ kHz		-82	-76	dB
		$f_i = 100$ kHz		-80		
SNR	Signal-to-noise ratio	$f_i = 20$ kHz	71	72		dB
		$f_i = 100$ kHz		71		
ENOB	Effective number of bits	$f_i = 20$ kHz	11.3	11.7		Bits
		$f_i = 100$ kHz		11.3		
SFDR	Spurious free dynamic range	$f_i = 20$ kHz	78	83		dB
		$f_i = 100$ kHz		80		
	Analog input bandwidth	Full power bandwidth, -3 dB		1		MHz
		Full power bandwidth, -1 dB		700		kHz
	Channel-to-channel Isolation	Fixed channel in conversion mode 00, $f_i = 35$ kHz, See Note 8		81		dB

† All typical values are at $T_A = 25^\circ\text{C}$.

- NOTES:
- Linear error is the maximum deviation from the best fit straight line through the A/D transfer characteristics.
 - Bipolar zero error is the difference between 10000000000 and the converted output for zero input voltage; positive full-scale error is the difference between 11111111111 and the converted output for positive full-scale input voltage (10 V); negative full-scale error is the difference between 00000000000 and the converted output for negative full-scale input voltage (-10 V).
 - It is measured by applying a full-scale of 35 kHz signal to other channels and determining how much the signal is attenuated in the channel of interest. The converter samples this examined channel continuously. The channel-to-channel isolation is degraded if the converter samples different channels alternately.



TLC3574, TLC3578, TLC2574, TLC2578
5-V ANALOG, 3-/5-V DIGITAL, 14-/12-BIT, 200-KSPS, 4-/8-CHANNEL
SERIAL ANALOG-TO-DIGITAL CONVERTERS WITH ± 10 -V INPUTS

SLAS262C – OCTOBER 2000 – REVISED MAY 2003

TLC2574I N package device AC/DC performance

PARAMETER		TEST CONDITIONS	MIN	TYP†	MAX	UNIT
DC Accuracy						
E_L	Integral linearity error	see Note 6	-1	± 0.7	1	LSB
E_D	Differential linearity error		-1	± 0.7	1	LSB
E_O	Bipolar zero error	see Note 7	-0.30	± 0.08	0.36	%FS
$E_{FS(+)}$	Positive full-scale error	see Note 7	-0.55	± 0.04	0.61	%FS
$E_{FS(-)}$	Negative full-scale error	see Note 7	-0.30	± 0.13	0.79	%FS
AC Accuracy						
SINAD	Signal-to-noise + distortion	$f_i = 20$ kHz	70	72		dB
		$f_i = 100$ kHz		70		
THD	Total harmonic distortion	$f_i = 20$ kHz		-82	-76	dB
		$f_i = 100$ kHz		-75		
SNR	Signal-to-noise ratio	$f_i = 20$ kHz	70	72		dB
		$f_i = 100$ kHz		71		
ENOB	Effective number of bits	$f_i = 20$ kHz	11.3	11.7		Bits
		$f_i = 100$ kHz		11.3		
SFDR	Spurious free dynamic range	$f_i = 20$ kHz	77	83		dB
		$f_i = 100$ kHz		75		
	Analog input bandwidth	Full power bandwidth, -3 dB		1		MHz
		Full power bandwidth, -1 dB		700		kHz
	Channel-to-channel Isolation	Fixed channel in conversion mode 00, $f_i = 35$ kHz, See Note 8		81		dB

† All typical values are at $T_A = 25^\circ\text{C}$.

- NOTES:
6. Linear error is the maximum deviation from the best fit straight line through the A/D transfer characteristics.
 7. Bipolar zero error is the difference between 10000000000 and the converted output for zero input voltage; positive full-scale error is the difference between 11111111111 and the converted output for positive full-scale input voltage (10 V); negative full-scale error is the difference between 00000000000 and the converted output for negative full-scale input voltage (-10 V).
 8. It is measured by applying a full-scale of 35 kHz signal to other channels and determining how much the signal is attenuated in the channel of interest. The converter samples this examined channel continuously. The channel-to-channel isolation is degraded if the converter samples different channels alternately.



TLC3574, TLC3578, TLC2574, TLC2578

5-V ANALOG, 3-/5-V DIGITAL, 14-/12-BIT, 200-KSPS, 4-/8-CHANNEL SERIAL ANALOG-TO-DIGITAL CONVERTERS WITH ± 10 -V INPUTS

SLAS262C – OCTOBER 2000 – REVISED MAY 2003

timing requirements over recommended operating free-air temperature range, $V_{DD} = 5$ V, $DV_{DD} = 5$ V, $V_{REFP} = 4$ V, $V_{REFM} = 0$ V, SCLK frequency = 25 MHz (unless otherwise noted)

SCLK, SDI, SDO, EOC and \overline{INT}

PARAMETERS		MIN	TYP	MAX	UNIT
$t_{c(1)}$	Cycle time of SCLK, 25 pF load (see Note 10)	$DV_{DD} = 2.7$ V	100		ns
		$DV_{DD} = 5$ V	40		
$t_{w(1)}$	Pulse width of SCLK High, at 25-pF load	40%		60%	$t_{c(1)}$
$t_{r(1)}$	Rise time for \overline{INT} and EOC, at 10-pF load	$DV_{DD} = 5$ V		6	ns
		$DV_{DD} = 2.7$ V		10	
$t_{f(1)}$	Fall time for \overline{INT} and EOC, at 10-pF load	$DV_{DD} = 5$ V		6	ns
		$DV_{DD} = 2.7$ V		10	
$t_{su(1)}$	Setup time, new SDI valid (reaches 90% final level) before the falling edge of SCLK, at 25-pF load	6		–	ns
$t_{h(1)}$	Hold time, old SDI hold (reaches 10% of old data level) after falling edge of SCLK, at 25-pF load	0		–	ns
$t_{d(1)}$	Delay time, new SDO valid (reaches 90% of final level) after SCLK rising edge, at 10-pF load (see Note 11)	$DV_{DD} = 5$ V	0	10	ns
		$DV_{DD} = 2.7$ V	0	23	
$t_{h(2)}$	Hold time, old SDO hold (reaches 10% of old data level) after SCLK rising edge, at 10-pF load	0		–	ns
$t_{d(2)}$	Delay time, delay from the falling edge of 16th SCLK to EOC falling edge, normal sampling, at 10-pF load	0		6	ns
$t_{d(3)}$	Delay time, delay from the falling edge of 16th SCLK to \overline{INT} falling edge, at 10-pF load (see Notes 11 and 12)	$t_{(conv)}$		$t_{(conv)}+6$	ns

NOTES: 9. The minimum pulse width of SCLK high and low is 12.5 ns.

10. Specified by design

11. For normal short sampling, $t_{d(3)}$ is the delay from the falling edge of 16th SCLK to the falling edge of \overline{INT} .

For normal long sampling, $t_{d(3)}$ is the delay from the falling edge of 48th SCLK to the falling edge of \overline{INT} . Conversion time, $t_{(conv)}$, is equal to $18 \times OSC + 15$ ns (for TLC3574 and TLC3578) or $13 \times OSC + 15$ ns (for TLC2574 and TLC2578) when using internal OSC as conversion clock, or $72 \times t_{c(1)} + 15$ ns (for TLC3574 and TLC3578) or $52 \times t_{c(1)} + 15$ ns (for TLC2574 and TLC2578) when external SCLK is conversion clock source.

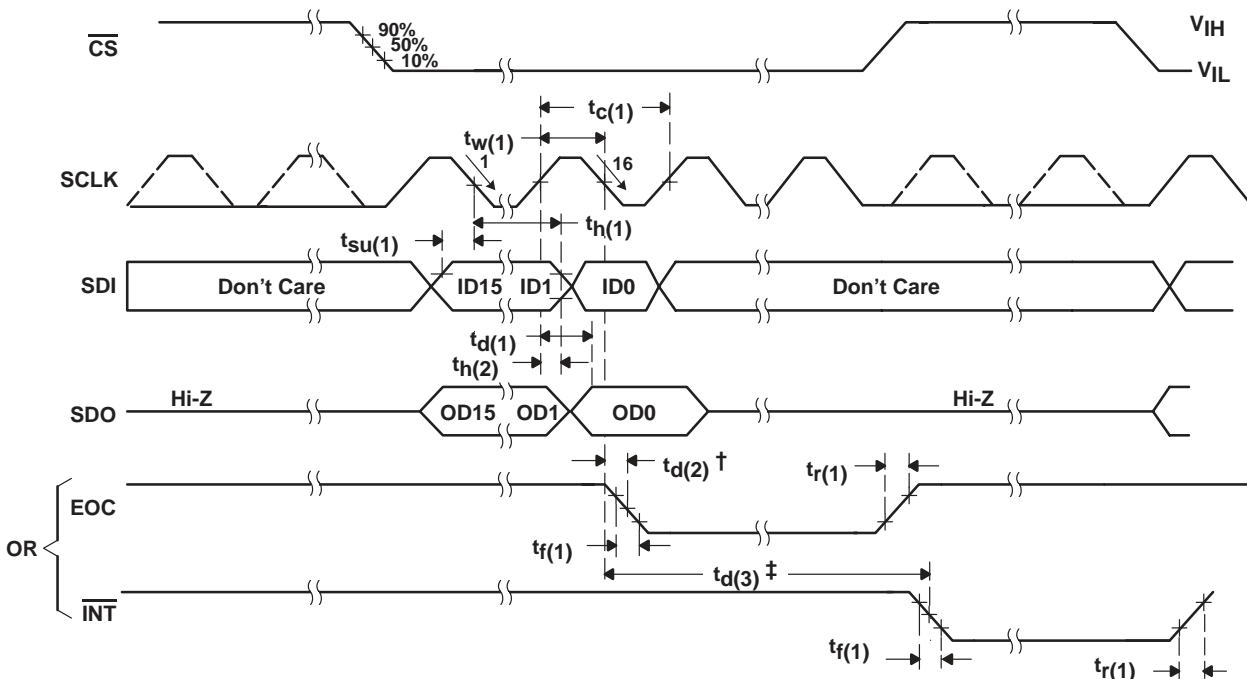

† For normal long sampling, $t_{d(2)}$ is the delay time of EOC low after the falling edge of 48th SCLK.

‡ For normal long sampling, $t_{d(3)}$ is the delay time of \overline{INT} low after the falling edge of 48th SCLK.

--- The dotted line means signal may or may not exist, depending on application. It must be ignored.

Normal sampling mode, \overline{CS} initiates the conversion, FS must be tied to high. When \overline{CS} is high, SDO is in Hi-Z, all inputs (FS, SCLK, SDI) are inactive and are ignored.

Figure 1. Critical Timing for SCLK, SDI, SDO, EOC and \overline{INT}

TLC3574, TLC3578, TLC2574, TLC2578
5-V ANALOG, 3-/5-V DIGITAL, 14-/12-BIT, 200-KSPS, 4-/8-CHANNEL
SERIAL ANALOG-TO-DIGITAL CONVERTERS WITH ± 10 -V INPUTS

SLAS262C – OCTOBER 2000 – REVISED MAY 2003

timing requirements over recommended operating free-air temperature range, $V_{DD} = 5$ V, $DV_{DD} = 5$ V, $V_{REFP} = 4$ V, $V_{REFM} = 0$ V, SCLK frequency = 25 MHz (unless otherwise noted) (continued)

CS trigger

PARAMETERS		MIN	TYP	MAX	UNIT
$t_{su(2)}$	Setup time, \overline{CS} falling edge before SCLK rising edge, at 25-pF load	12			ns
$t_{d(4)}$	Delay time, delay time from the falling edge of 16th SCLK to \overline{CS} rising edge, at 25 pF load (see Note 12)	5			ns
$t_w(2)$	Pulse width of \overline{CS} high, at 25-pF load	1			$t_c(1)$
$t_{d(5)}$	Delay time, delay from \overline{CS} falling edge to MSB of SDO valid (reaches 90% final level), at 10 pF load	$DV_{DD} = 5$ V	0	12	ns
		$DV_{DD} = 2.7$ V	0	30†	
$t_{d(6)}$	Delay time, delay from \overline{CS} rising edge to SDO 3-state, at 10-pF load	0		6	ns
$t_{d(7)}$	Delay time, delay from \overline{CS} falling edge to \overline{INT} rising edge, at 10-pF load	$DV_{DD} = 5$ V	0	6	ns
		$DV_{DD} = 2.7$ V	0	16†	

† Specified by design

NOTE 12: For normal short sampling, $t_{d(4)}$ is the delay time from the falling edge of 16th SCLK to \overline{CS} rising edge. For normal long sampling, $t_{d(4)}$ is the delay time from the falling edge of 48th SCLK to \overline{CS} rising edge.

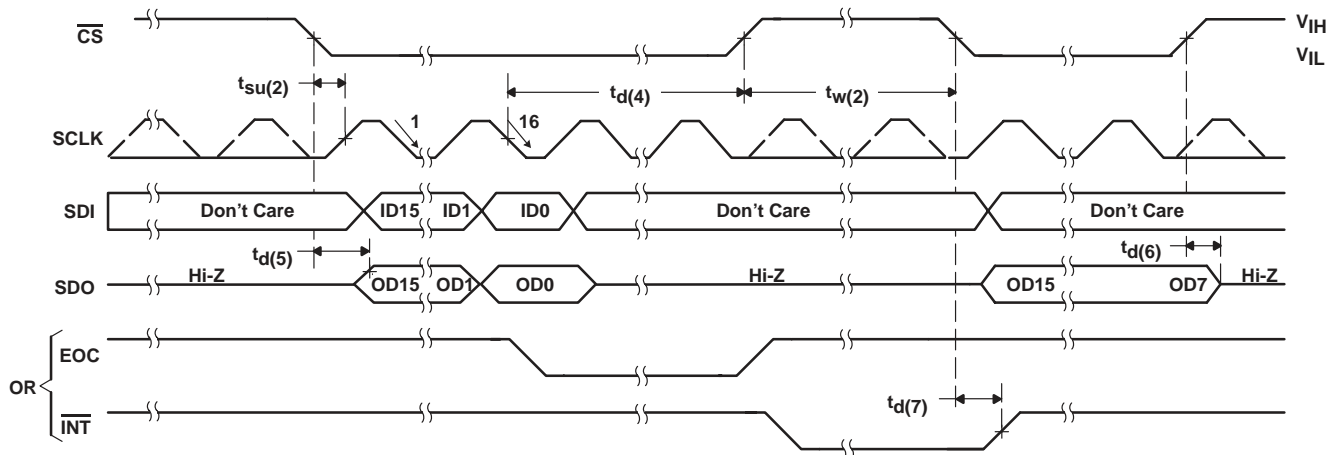

--- The dotted line means signal may or may not exist, depending on application. It must be ignored. Normal sampling mode, \overline{CS} initiates the conversion, FS must be tied to high. When \overline{CS} is high, SDO is in Hi-Z, all inputs (FS, SCLK, SDI) are inactive and are ignored.

Figure 2. Critical Timing for \overline{CS} Trigger

TLC3574, TLC3578, TLC2574, TLC2578
5-V ANALOG, 3-/5-V DIGITAL, 14-/12-BIT, 200-KSPS, 4-/8-CHANNEL
SERIAL ANALOG-TO-DIGITAL CONVERTERS WITH ± 10 -V INPUTS

SLAS262C – OCTOBER 2000 – REVISED MAY 2003

timing requirements over recommended operating free-air temperature range, $V_{DD} = 5$ V, $DV_{DD} = 5$ V, $V_{REFP} = 4$ V, $V_{REFM} = 0$ V, SCLK frequency = 25 MHz (unless otherwise noted) (continued)

FS trigger

PARAMETERS		MIN	TYP	MAX	UNIT
$t_{d(8)}$	Delay time, delay from \overline{CS} falling edge to FS rising edge at 25-pF load	0.5			$t_{c(1)}$
$t_{su(3)}$	Setup time, FS rising edge before SCLK falling edge at 25-pF load	$0.25 \times t_{c(1)}$	$t_{c(1)}$	$0.5 \times t_{c(1)} + 5$	ns
$t_{w(3)}$	Pulse width of FS high, at 25-pF load	$0.75 \times t_{c(1)}$	$t_{c(1)}$	$1.25 \times t_{c(1)}$	ns
$t_{d(9)}$	Delay time, delay from FS rising edge to MSB of SDO valid (reaches 90% final level), at 10-pF load	$DV_{DD} = 5$ V		26	ns
		$DV_{DD} = 2.7$ V		30†	
$t_{d(10)}$	Delay time, delay from FS rising edge to next FS rising edge, at 25-pF load	Required sampling time + conversion time			ns
$t_{d(11)}$	Delay time, delay from FS rising edge to \overline{INT} rising edge, at 10-pF load	$DV_{DD} = 5$ V	0	6	ns
		$DV_{DD} = 2.7$ V	0	16†	

† Specified by design

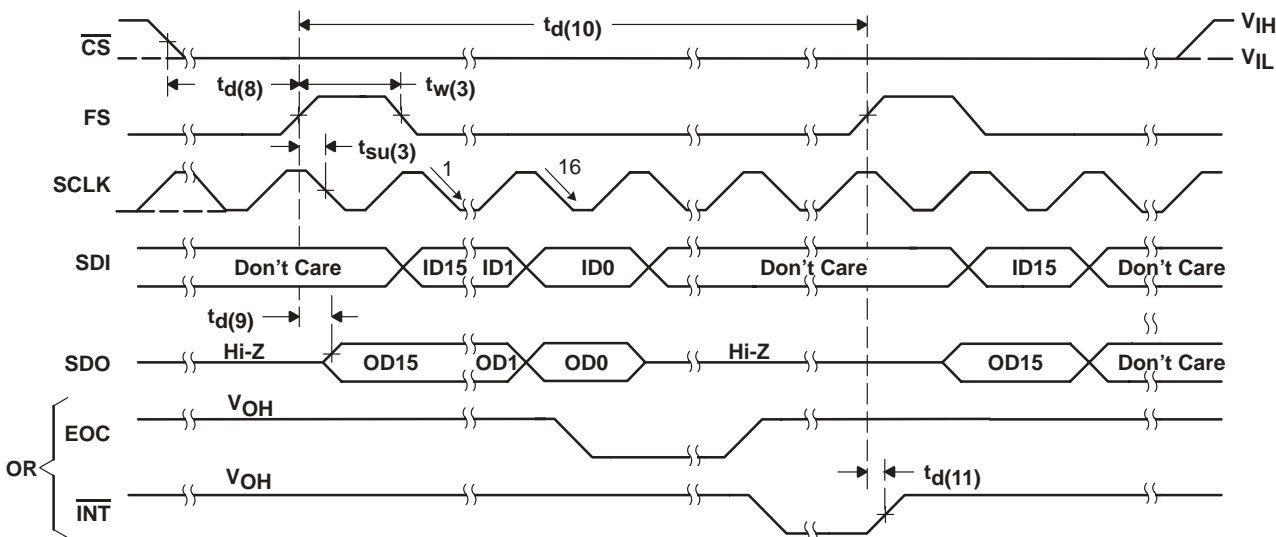

--- The dotted line means signal may or may not exist, depending on application. It must be ignored.
 Normal sampling mode, FS initiates the conversion, \overline{CS} can be tied to low. When \overline{CS} is high, SDO is in Hi-Z, all inputs (FS, SCLK, SDI) are inactive and are ignored.

Figure 3. Critical Timing for FS Trigger

TLC3574, TLC3578, TLC2574, TLC2578
5-V ANALOG, 3-/5-V DIGITAL, 14-/12-BIT, 200-KSPS, 4-/8-CHANNEL
SERIAL ANALOG-TO-DIGITAL CONVERTERS WITH ± 10 -V INPUTS

SLAS262C – OCTOBER 2000 – REVISED MAY 2003

timing requirements over recommended operating free-air temperature range, $AV_{DD} = 5$ V, $DV_{DD} = 5$ V, $V_{REFP} = 4$ V, $V_{REFM} = 0$ V, SCLK frequency = 25 MHz (unless otherwise noted) (continued)

\overline{CSTART} trigger

PARAMETERS		MIN	TYP	MAX	UNIT
$t_{d(12)}$	Delay time, delay from \overline{CSTART} rising edge to EOC falling edge, at 10-pF load	0	15	21	ns
$t_{w(4)}$	Pulse width of \overline{CSTART} low, at 25-pF load (see Note 13)	$t_{(sample_reg)}+0.4$			μ s
$t_{d(13)}$	Delay time, delay from \overline{CSTART} rising edge to \overline{CSTART} falling edge, at 25-pF load (see Note 13 and 14)	$t_{(conv)}+15$			ns
$t_{d(14)}$	Delay time, delay from \overline{CSTART} rising edge to \overline{INT} falling edge, at 10-pF load (see Note 13 and 14)	$t_{(conv)}+15$		$t_{(conv)}+21$	ns
$t_{d(15)}$	Delay time, delay from \overline{CSTART} falling edge to \overline{INT} rising edge, at 10-pF load	0		6	ns

- NOTES: 13. The pulse width of the \overline{CSTART} must be not less than the required sampling time.
 The delay from \overline{CSTART} rising edge to following \overline{CSTART} falling edge must be not less than the required conversion time.
 The delay from \overline{CSTART} rising edge to the \overline{INT} falling edge is equal to the conversion time.
 14. The maximum rate of SCLK is 25 MHz for normal long sampling and 10 MHz for normal short sampling.

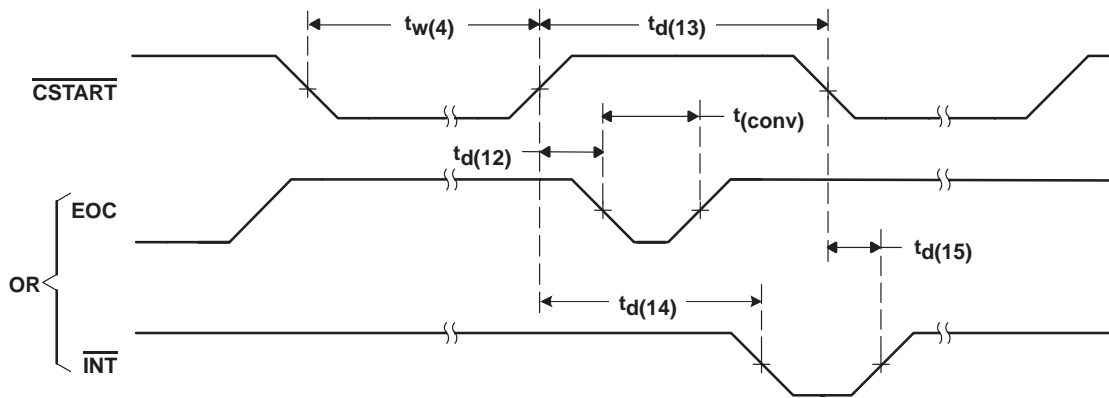

Figure 4. Critical Timing for Extended Sampling (\overline{CSTART} Trigger)

circuit description

converter

The converters include a successive-approximation ADC utilizing a charge redistribution DAC. Figure 5 shows a simplified block diagram of the ADC. The sampling capacitor acquires the signal on Ain during the sampling period. When the conversion process starts, the control logic directs the charge redistribution DAC to add and subtract fixed amounts of charge from the sampling capacitor to bring the comparator into a balanced condition. When balanced, the conversion is complete and the ADC output code is generated.

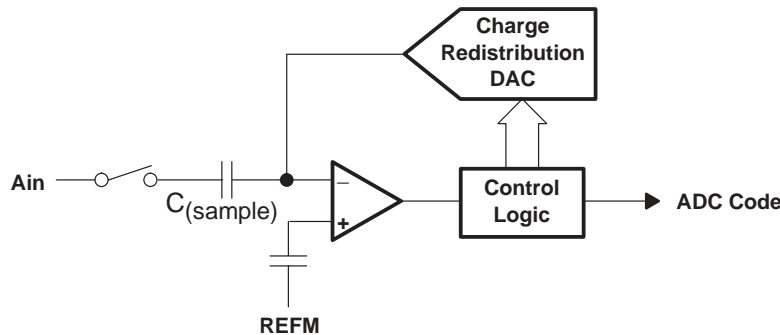

Figure 5. Simplified Block Diagram of the Successive-Approximation System

analog input range and internal test voltages

TLC3578 and TLC2578 have 8 analog inputs (TLC3574 and TLC2574 have 4) and three test voltages. The inputs are selected by the analog multiplexer according to the command entered (see Table 1). The input multiplexer is a break-before-make type to reduce input-to-input noise injection resulting from channel switching.

All converters are specified for bipolar input range of ± 10 V. The input signal is scaled to 0–4 V at the SAR ADC input via the bipolar scaling circuit (see the functional block diagram and the equivalent analog input circuit): –10 V to 0 V, 10 V to 4 V, and 0 V to 2 V.

analog input mode

Two input signal modes can be selected: single-ended input and pseudodifferential input.

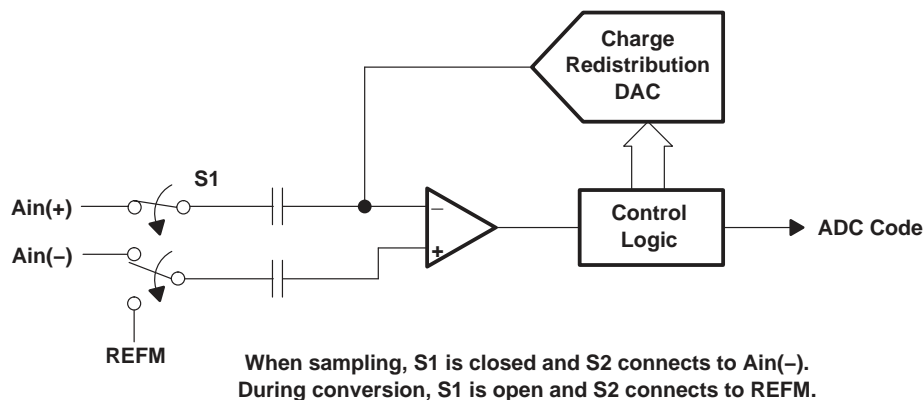

Figure 6. Simplified Pseudodifferential Input Circuit

Pseudodifferential input refers to the negative input, Ain(-). Its voltage is limited in magnitude to ± 1 V. The input frequency limit of Ain(-) is the same as the positive input Ain(+). This mode is normally used for ground noise rejection or dc offset.

TLC3574, TLC3578, TLC2574, TLC2578

5-V ANALOG, 3-/5-V DIGITAL, 14-/12-BIT, 200-KSPS, 4-/8-CHANNEL SERIAL ANALOG-TO-DIGITAL CONVERTERS WITH ± 10 -V INPUTS

SLAS262C – OCTOBER 2000 – REVISED MAY 2003

analog input mode (continued)

When pseudodifferential mode is selected, only two analog input channel pairs are available for the TLC3574 and TLC2574 and four channel pairs for the TLC3578 and TLC2578, because half the inputs are used as the negative input.

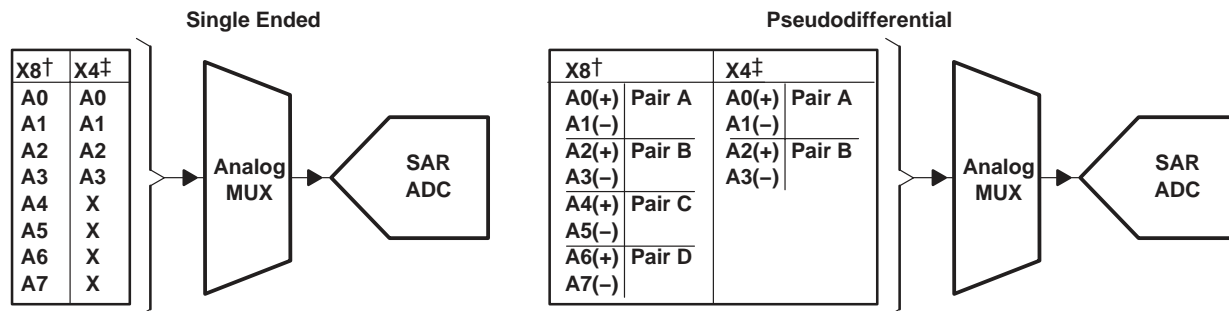

† TLC3578 and TLC2578

‡ TLC3574 and TLC2574

Figure 7. Pin Assignment of Single-Ended Input vs Pseudodifferential Input

reference voltage

The external reference is applied to the reference-input pins (REFP and REFM). REFM should connect to analog ground. REFP is 4 V. Install decoupling capacitors (10 μ F in parallel with 0.1 μ F) between REFP and REFM, and compensation capacitors (0.1 μ F) between COMP and AGND.

ideal conversion characteristics

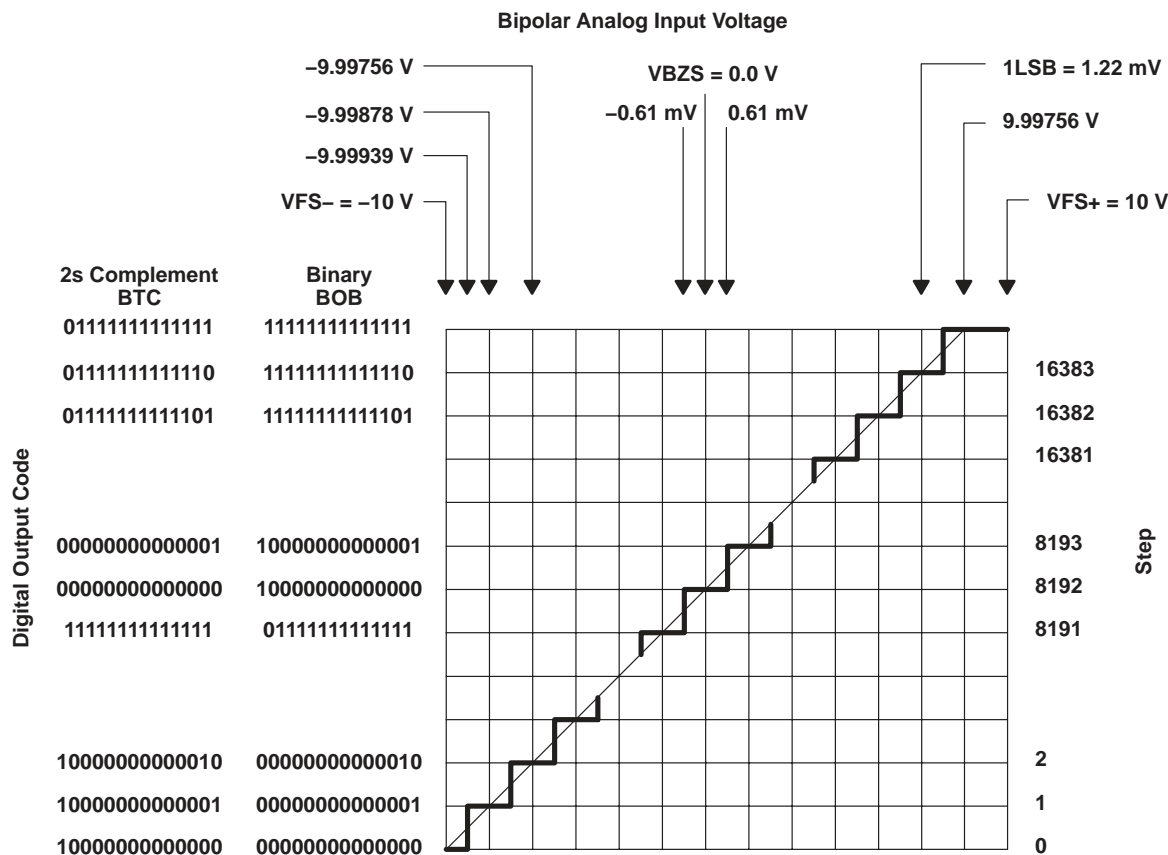

TLC3574, TLC3578, TLC2574, TLC2578
5-V ANALOG, 3-/5-V DIGITAL, 14-/12-BIT, 200-KSPS, 4-/8-CHANNEL
SERIAL ANALOG-TO-DIGITAL CONVERTERS WITH ± 10 -V INPUTS

SLAS262C – OCTOBER 2000 – REVISED MAY 2003

circuit description (continued)

data format

INPUT DATA FORMAT (BINARY)	
MSB	LSB
ID[15:12]	ID[11:0]
Command	Configuration data field or filled with zeros

OUTPUT DATA FORMAT (READ CONVERSION/FIFO)			
TLC3574 and TLC3578		TLC2574 and TLC2578	
MSB	LSB	MSB	LSB
OD[15:2]	OD[1:0]	OD[15:4]	OD[3:0]
Conversion result	Don't Care	Conversion result	Don't Care

14-BIT (TLC3574/78)	12-BIT (TLC2574/78)
Bipolar Input, Offset Binary: (BOB) Negative full scale code = VFS- = 0000h, Vcode = -10 V Midscale code = VBZS = 2000h, Vcode = 0 V Positive full scale code = VFS+ = 3FFFh, Vcode = 10 V - 1 LSB Bipolar Input, Binary 2s Complement: (BTC) Negative full scale code = VFS- = 2000 h, Vcode = -10 V Midscale code = VBZS = 0000h, Vcode = 0 V Positive full scale code = VFS+ = 1FFFh, Vcode = 10 V - 1 LSB	Bipolar Offset Binary Output: (BOB) Negative full scale code = 000h, Vcode = -10 V Midscale code = 800h, Vcode = 0 V Positive full scale code = FFFh, Vcode = 10 V - 1 LSB Bipolar Input, Binary 2s Complement: (BTC) Negative full scale code = 800 h, Vcode = -10 V Midscale code = 000h, Vcode = 0 V Positive full scale code = 7FFh, Vcode = 10 V - 1 LSB

operation description

The converter samples the selected analog input signal, then converts the sample into digital output according to the selected output format. The converter has four digital input pins (SDI, SCLK, \overline{CS} , and FS) and one digital output pin (SDO) to communicate with the host device. SDI is a serial data input pin, SDO is a serial data output pin, and SCLK is a serial clock from host device. This clock is used to clock the serial data transfer. It can also be used as conversion clock source (see Table 2). \overline{CS} and FS are used to start the operation. The converter has a \overline{CSTART} pin for external hardware sampling and conversion trigger, and \overline{INT}/EOC for interrupt purpose.

device initialization

After power on, the status of $\overline{EOC}/\overline{INT}$ is initially high, and the input data register is set to all zeros. The device must be initialized before starting conversion. The initialization procedure depends on the working mode. The first conversion result must be ignored after power on.

Hardware Default Mode: Nonprogrammed mode, default. After power on, two consecutive active cycles initiated by \overline{CS} or FS put the device into hardware default mode if SDI is tied to DV_{DD} . Each of these cycles must last 16 SCLK at least. These cycles initialize the converter and load CFR register with 800h (bipolar offset binary output code, normal long sampling, internal OSC, single-ended input, one-shot conversion mode, and $\overline{EOC}/\overline{INT}$ pin as \overline{INT}). No additional software configuration is required.

Software Programmed Mode: Programmed. If the converter needs to be configured, The host must write A000H into converters first after power on, then performs the WRITE CFR operation to configure the device.

start of operation cycle

Each operation consists of several actions that the converter takes according to the command from the host. The operation cycle includes three periods: command period, sampling period, and conversion period. In the command period, the device decodes the command from host. In the sampling period, the device samples the selected analog signal according to the command. In the conversion period, the sample of the analog signal is converted to digital format. The operation cycle starts from the command period, which is followed by one or several sampling and conversion periods (depending on the setting), and finishes at the end of last conversion period. The operation is initiated by the falling edge of \overline{CS} or the rising edge of FS.



TLC3574, TLC3578, TLC2574, TLC2578

5-V ANALOG, 3-/5-V DIGITAL, 14-/12-BIT, 200-KSPS, 4-/8-CHANNEL SERIAL ANALOG-TO-DIGITAL CONVERTERS WITH ± 10 -V INPUTS

SLAS262C – OCTOBER 2000 – REVISED MAY 2003

start of operation cycle (continued)

\overline{CS} initiates the operation: If FS is high at the falling edge of \overline{CS} , the falling edge of \overline{CS} initiates the operation. When \overline{CS} is high, SDO is in high-impedance state, the signals on SDI are ignored, and SCLK is disabled to clock the serial data. The falling edge of \overline{CS} resets the internal 4-bit counter and enables SDO, SDI, and SCLK. The MSB of the input data via SDI, ID(15), is latched at the first falling edge of SCLK following the falling edge of \overline{CS} . The MSB of output data from SDO, OD(15), is valid before this SCLK falling edge. This mode works as an SPI interface when \overline{CS} is used as SLAVE SELECT (\overline{SS}). It also can be used as normal DSP interface if \overline{CS} connects to the frame sync output of the host DSP. *FS must be tied to high in this mode.*

FS initiates the operation: If FS is low at the falling edge of \overline{CS} , the rising edge of FS initiates the operation. It resets the internal 4-bit counter, and enables SDI, SDO, and SCLK. The ID(15) is latched at the first falling edge of SCLK following the falling edge of FS. OD(15) is valid before this falling edge of SCLK. This mode is used to interface the converter with a serial port of the host DSP. The FS of the device is connected to the frame sync of the host DSP. When several devices are connected to one DSP serial port, \overline{CS} is used as chip select to allow the host DSP to access each device individually. If only one converter is used, \overline{CS} can be tied to low.

After the initiation, the remaining SDI data bits (if any) are shifted in and the remaining bits of SDO (if any) are shifted out at the rising edge of SCLK. The input data are latched at the falling edge of SCLK, and the output data are valid before the falling edge of SCLK. After the 4-bit counter reaches 16, the SDO goes to high-impedance state. The output data from SDO is the previous conversion result in one shot conversion mode, or the contents in the top of FIFO when FIFO is used (refer to Figure 20).

command period

After the rising edge of FS (FS triggers the operation) or the falling edge of \overline{CS} (\overline{CS} triggers the operation), SDI, SDO, and SCLK are enabled. The first four SCLK clocks form the command period. The four MSBs of input data, ID[15:12], are shifted in and decoded. These bits represent one of the 4-bit commands from the host, which defines the required operation (see Table 1). The four MSB of output, OD[15:12], are also shifted out via SDO during this period.

The commands are SELECT/CONVERSION, WRITE CFR, FIFO READ, and HARDWARE DEFAULT. The SELECT/CONVERSION command includes SELECT ANALOG INPUT and SELECT TEST commands. All cause a select/conversion operation. They select the analog signal being converted, and start the sampling/conversion process after the selection. WRITE CFR causes the configuration operation, which writes the device configuration information into CFR register. FIFO READ reads the contents in FIFO. Hardware default mode sets the device into the hardware default mode.

After the command period, the remaining 12 bits of SDI are written into the CFR register to configure the device if the command is *WRITE CFR*. Otherwise, these bits are ignored. The configuration is retained in the autopower-down state. If the SCLK stops (while \overline{CS} remains low) after the first eight bits are entered, the next eight bits can be entered after the SCLK resumes. The data on SDI are ignored after the 4-bit counter counts to 16 (falling edge of SCLK) or the low-to-high transition of \overline{CS} , whichever happens first.

The remaining 12 bits of output data are shifted out from SDO if the command is SELECT/CONVERSION or *FIFO READ*. Otherwise, the data on SDO must be ignored. In any case, the SDO goes into high-impedance state after the 4-bit counter counts to 16 (falling edge of SCLK) or the low-to-high transition of \overline{CS} , whichever happens first.



TLC3574, TLC3578, TLC2574, TLC2578
5-V ANALOG, 3-/5-V DIGITAL, 14-/12-BIT, 200-KSPS, 4-/8-CHANNEL
SERIAL ANALOG-TO-DIGITAL CONVERTERS WITH ± 10 -V INPUTS

SLAS262C – OCTOBER 2000 – REVISED MAY 2003

command period (continued)

Table 1. Command Set (CMR)

SDI Bit D[15:12]		TLC3578 / 2578 COMMAND	TLC3574 / 2574 COMMAND
BINARY	HEX		
0000b	0h	SELECT analog input channel 0	SELECT analog input channel 0
0001b	1h	SELECT analog input channel 1	SELECT analog input channel 1
0010b	2h	SELECT analog input channel 2	SELECT analog input channel 2
0011b	3h	SELECT analog input channel 3	SELECT analog input channel 3
0100b	4h	SELECT analog input channel 4	SELECT analog input channel 0
0101b	5h	SELECT analog input channel 5	SELECT analog input channel 1
0110b	6h	SELECT analog input channel 6	SELECT analog input channel 2
0111b	7h	SELECT analog input channel 7	SELECT analog input channel 3
1000b	8h	Reserved	
1001b	9h	Reserved	
1010b	Ah	WRITE CFR, the last 12 bits of SDI are written into CFR. This command resets FIFO.	
1011b	Bh	SELECT TEST, voltage = (REFP+REFM)/2 (see Note 15)	
1100b	Ch	SELECT TEST, voltage = REFM (see Note 16)	
1101b	Dh	SELECT TEST, voltage = REFP (see Note 17)	
1110b	Eh	FIFO READ, FIFO contents is shown on SDO; (see Note 18)	
1111b	Fh	HARDWARE DEFAULT mode, CFR is loaded with 800h	

- NOTES: 15. The output code = mid-scale code + bipolar zero error
16. The output code = negative full-scale code + negative full-scale error
17. The output code = positive full-scale code + positive full-scale error
18. The TLC3574 and TLC3578, OD [15:2] is conversion result, OD [1:0] don't care
The TLC2574 and TLC2578, OD [15:4] is conversion result, OD [3:0] don't care



TLC3574, TLC3578, TLC2574, TLC2578
5-V ANALOG, 3-/5-V DIGITAL, 14-/12-BIT, 200-KSPS, 4-/8-CHANNEL
SERIAL ANALOG-TO-DIGITAL CONVERTERS WITH ± 10 -V INPUTS

SLAS262C – OCTOBER 2000 – REVISED MAY 2003

detailed description (continued)

Table 2. Configuration Register (CFR) Bit Definition

SDI BIT	DEFINITION					
D11	Always 1. Otherwise the performance is degraded.					
D10	Conversion output code format select: 0: BOB (bipolar offset binary); 1: BTC (binary 2s complement)					
D9	Sample period select for normal sampling. Don't care in extended sampling. 0: Long sampling (4x) 44 SCLKs; 1: Short sampling 12 SCLKs					
D8	Conversion clock source select: 0: Conversion clock = Internal OSC; 1: Conversion clock = SCLK/4					
D7	Input mode select: 0: Single-ended; 1: Pseudodifferential. Pin configuration shown below.					
	Pin Configuration of TLC3578 and TLC2578			Pin Configuration of TLC3574 and TLC2574		
	Pin No.	Single-ended	Pseudodifferential polarity	Pin No.	Single-ended	Pseudodifferential polarity
	9	A0	Plus Pair A	9	A0	PLUS Pair A
	10	A1	Minus	10	A1	MINUS
	11	A2	Plus Pair B	11	A2	PLUS Pair B
	12	A3	Minus	12	A3	MINUS
13	A4	Plus Pair C				
14	A5	Minus				
15	A6	Plus Pair D				
16	A7	Minus				
D[6:5]	Conversion mode select 00: One shot mode 01: Repeat mode 10: Sweep mode 11: Repeat sweep mode.					
D[4:3]	Sweep auto sequence select (Note: These bits only take effect in conversion mode 10 and 11.)					
	TLC3578 and TLC2578			TLC3574 and TLC2574		
	Single-ended (by ch)		Pseudodifferential (by pair)	Single-ended (by ch)		Pseudodifferential (by pair)
	00: 0-1-2-3-4-5-6-7 01: 0-2-4-6-0-2-4-6 10: 0-0-2-2-4-4-6-6 11: 0-2-0-2-0-2-0-2		00: N/A 01: A-B-C-D-A-B-C-D 10: A-A-B-B-C-C-D-D 11: A-B-A-B-A-B-A-B	00: 0-1-2-3-0-1-2-3 01: 0-2-0-2-0-2-0-2 10: 0-0-1-1-2-2-3-3 11: 0-0-0-0-2-2-2-2		00: N/A 01: A-B-A-B-A-B-A-B 10: N/A 11: A-A-A-A-B-B-B-B
D2	EOC/ $\overline{\text{INT}}$ pin function select 0: Pin used as $\overline{\text{INT}}$ 1: Pin used as EOC (for mode 00 only)					
D[1:0]	FIFO trigger level (sweep sequence length). Don't care in one shot mode. 00: Full ($\overline{\text{INT}}$ generated after FIFO Level 7 filled) 01: 3/4 ($\overline{\text{INT}}$ generated after FIFO Level 5 filled) 10: 1/2 ($\overline{\text{INT}}$ generated after FIFO Level 3 filled) 11: 1/4 ($\overline{\text{INT}}$ generated after FIFO Level 1 filled)					

sampling period

The sampling period follows the command period. The selected signal is sampled during this time. The device has three different sampling modes: normal short mode, normal long mode, and extended mode.

Normal Short Sampling Mode: Sampling time is controlled by the SCLK and lasts 12 SCLK periods. At the end of sampling, the converter automatically starts the conversion period. After the configuration, the normal sampling starts automatically after the falling edge of fourth SCLK that follows the falling edge of $\overline{\text{CS}}$ if $\overline{\text{CS}}$ triggers the operation, or follows the rising edge of FS if FS initiates the operation, except the FIFO READ and WRITE CFR commands.



sampling period (continued)

Normal Long Sampling Mode: It is the same as normal short sampling, except that it lasts 44 SCLKs periods to complete the sampling.

Extended Sampling Mode: The external signal, $\overline{\text{CSTART}}$, triggers sampling and conversion. SCLK is not used for sampling. SCLK is also not needed for conversion if the internal conversion clock is selected. The falling edge of $\overline{\text{CSTART}}$ begins the sampling of the selected analog input. The sampling continues while $\overline{\text{CSTART}}$ is low. The rising edge of $\overline{\text{CSTART}}$ ends the sampling, and starts the conversion (with about 15 ns internal delay). The occurrence of $\overline{\text{CSTART}}$ is independent of SCLK clock, $\overline{\text{CS}}$, and FS. However, the first $\overline{\text{CSTART}}$ cannot occur before the rising edge of the 11th SCLK. In other words, the falling edge of first $\overline{\text{CSTART}}$ can happen at or after the rising edge of 11th SCLK, but not before. The device enters the extended sampling mode at the falling edge of $\overline{\text{CSTART}}$ and exits this mode once $\overline{\text{CSTART}}$ goes to high followed by two consecutive falling edges of $\overline{\text{CS}}$ or two consecutive rising edges of FS (such as one read data operations followed by WRITE CFR). The first $\overline{\text{CS}}$ or FS does not cause conversion. Extended mode is used when a fast SCLK is not suitable for sampling, or when extended sampling period is needed to accommodate different input signal source impedance.

conversion period

The conversion period is the third portion of the operation cycle. It begins after the falling edge of 16th SCLK for the normal short sampling mode, or after the falling edge of 48th SCLK for the normal long sampling, or on the rising edge of $\overline{\text{CSTART}}$ (with 15 ns internal delay) for the extended sampling mode.

The conversion takes 18 conversion clocks plus 15 ns for TLC3574/78, 13 conversion clocks plus 15 ns for the TLC2574/78. The conversion clock source can be an internal oscillator, OSC, or an external clock, SCLK. The conversion clock is equal to the internal OSC if the internal clock is used, or equal to four SCLKs when the external clock is programmed. To avoid the premature termination of conversion, enough time for the conversion must be allowed between consecutive triggers. $\overline{\text{EOC}}$ goes to low at the beginning of the conversion period and goes to high at the end of the conversion period. $\overline{\text{INT}}$ goes to low at the end of this period, too.

conversion mode

Four different conversion modes (mode 00, 01, 10, 11) are available. The operation of each mode is slightly different, depending on how the converter samples and what host interface is used. Do not mix different types of triggers throughout the repeat or sweep operations.

ONE SHOT Mode (Mode 00): Each operation cycle performs one sampling and one conversion for the selected channel. FIFO is not used. When $\overline{\text{EOC}}$ is selected, it is generated while the conversion period is in progress. Otherwise, $\overline{\text{INT}}$ is generated after the conversion is done. The result is output through the SDO pin during the next select/conversion operation.

REPEAT Mode (Mode 01): Each operation cycle performs multiple samplings and conversions for a fixed channel selected according to the 4-bit command. The results are stored in the FIFO. The number of samples to be taken equals the FIFO threshold programmed via D[1:0] in CFR register. Once the threshold is reached, $\overline{\text{INT}}$ is generated, and the operation ends. If the FIFO is not read after the conversions, the data is replaced in the next operation. The operation of this mode starts with the WRITE CFR commands to set conversion mode 01, then the SELECT/CONVERSION commands, followed by a number of samplings and conversions of the fixed channel (triggered by $\overline{\text{CS}}$, FS, or $\overline{\text{CSTART}}$) until the FIFO threshold is hit. If $\overline{\text{CS}}$ or FS triggers the sampling, the data on SDI must be any one of the SELECT CHANNEL commands. However, this data is a dummy code for setting the converter in conversion state. It does not change the existing channel selection set at the start of the operation until the FIFO is full. After the operation finishes, the host can read the FIFO, then reselect the channel and start the next REPEAT operation again; or immediately reselect the channel and start next REPEAT operation (by issuing $\overline{\text{CS}}$ or FS or $\overline{\text{CSTART}}$); or reconfigure the converter then start new operation according to the new setting. If $\overline{\text{CSTART}}$ triggers the sampling, host can also immediately start the next REPEAT operation (on the current channel) after the FIFO is full. Besides, if FS initiates the operation and $\overline{\text{CSTART}}$ triggers the samplings and conversions, $\overline{\text{CS}}$ must not toggle during the conversion. This mode allows the host to set up the converter, continue monitoring a fixed input, and to get a set of samples as needed.

TLC3574, TLC3578, TLC2574, TLC2578

5-V ANALOG, 3-/5-V DIGITAL, 14-/12-BIT, 200-KSPS, 4-/8-CHANNEL SERIAL ANALOG-TO-DIGITAL CONVERTERS WITH ± 10 -V INPUTS

SLAS262C – OCTOBER 2000 – REVISED MAY 2003

conversion mode (continued)

SWEEP Mode (Mode 10): During each operation, all of the channels listed in the SWEEP SEQUENCE (D[4:3] of CFR register) are sampled and converted one time according to the programmed sequence. The results are stored in the FIFO. When the FIFO threshold is reached, an interrupt ($\overline{\text{INT}}$) is generated, and the operation ends. If the FIFO threshold is reached before all of the listed channels are visited, the remaining channels are ignored. This allows the host to change the sweep sequence length. The mode 10 operation starts with the WRITE CFR command to set the sweep sequence. The following triggers ($\overline{\text{CS}}$, FS, or $\overline{\text{CSTART}}$, depending on the interface) start the samplings and conversions of the listed channels in sequence until the FIFO threshold is hit. If $\overline{\text{CS}}$ or FS starts the sampling, the SDI data must be any one of the SELECT commands to set the converter in conversion state. However, this command is a dummy code. It does not change the existing conversion sequence. After the FIFO is full, the converter waits for FIFO READ. It does nothing before the FIFO READ or WRITE CFR command is issued. The host must read the FIFO completely or WRITE CFR. If $\overline{\text{CSTART}}$ triggers the samplings, the host must issue an extra SELECT/CONVERSION command (select any channel) via $\overline{\text{CS}}$ or FS after the FIFO READ or WRITE CFR. This extra period is named the arm period and is used to set the converter into conversion state, but does not affect the existing conversion sequence. If FS initiates the operation and $\overline{\text{CSTART}}$ triggers the samplings and conversions, $\overline{\text{CS}}$ must not toggle during the conversion.

REPEAT SWEEP Mode (Mode 11): This mode works in the same way as mode 10, except that it is not necessary to read the FIFO before the next operation after the FIFO threshold is hit. The next sweep can repeat immediately, but the contents in the FIFO are replaced by the new results. The host can read the FIFO completely, then issue next SWEEP; or repeat the SWEEP immediately (with the existing sweep sequence) by issuing sampling/conversion triggers ($\overline{\text{CS}}$, FS or $\overline{\text{CSTART}}$); or change the device setting with the WRITE CFR command.

The memory effect of charge redistribution DAC exists when the mux switches from one channel to another. This degrades the channel-to-channel isolation if the channel changes after each conversion. For example, in mode 10 and 11, the isolation is about 70 dB for the sweep sequence 0-1-2-3-4. The memory effect can be reduced by increasing the sampling time or using sweep sequence 0-0-2-2-4-4-6-6 and ignoring the first sample of each channel.



TLC3574, TLC3578, TLC2574, TLC2578

5-V ANALOG, 3-/5-V DIGITAL, 14-/12-BIT, 200-KSPS, 4-/8-CHANNEL SERIAL ANALOG-TO-DIGITAL CONVERTERS WITH ± 10 -V INPUTS

SLAS262C – OCTOBER 2000 – REVISED MAY 2003

operation cycle timing

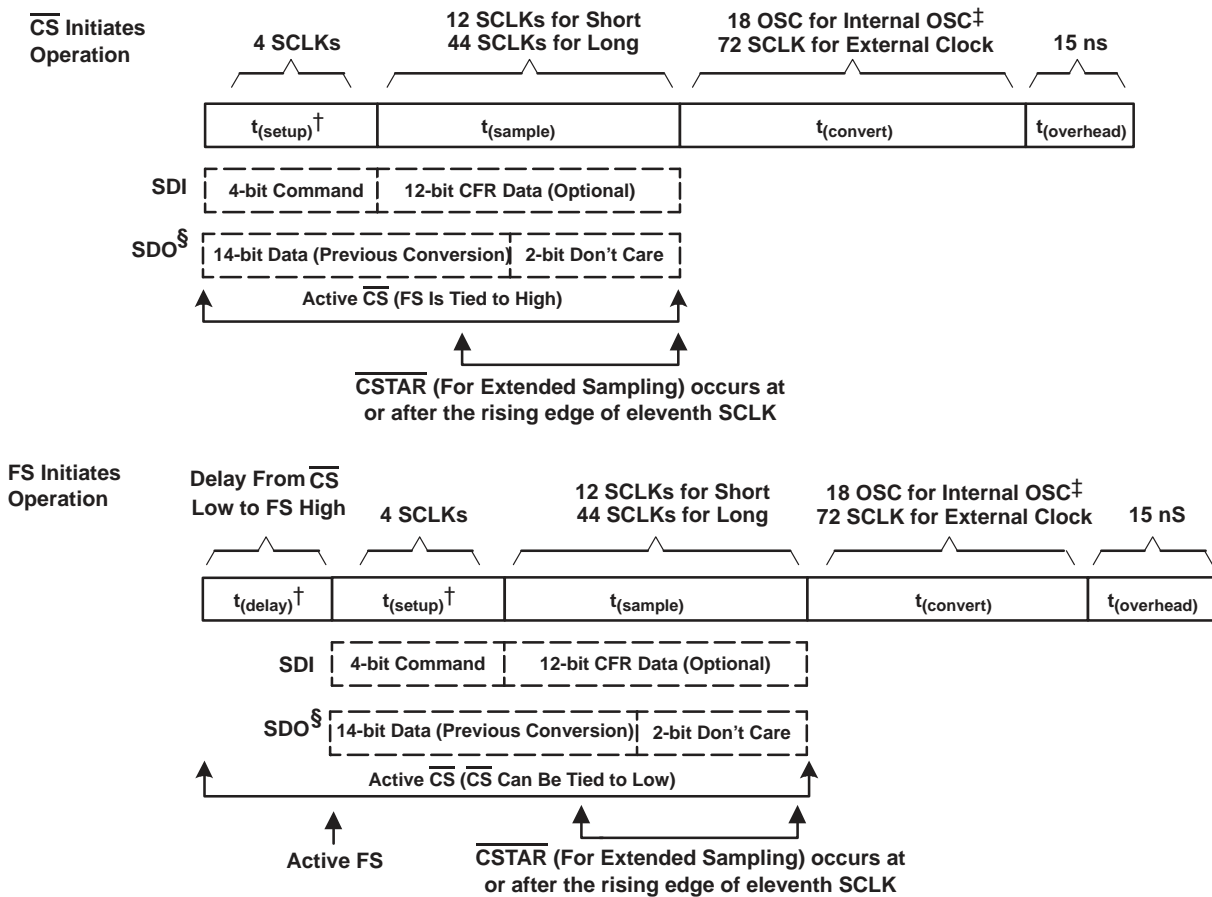

[†] Non JEDEC terms used.

[‡] 18 internal OSC or 72 SCLK for TLC3574 and TLC3578,

13 internal OSC or 52 SCLK for TLC2574 and TLC2578.

[§] For TLC3574 and TLC3578, 14-bits are result of previous conversion, last two bits are don't care. For TLC2574 and TLC2578, 12-bits are result of previous conversion, last four bits are don't care.

TLC3574, TLC3578, TLC2574, TLC2578
5-V ANALOG, 3-/5-V DIGITAL, 14-/12-BIT, 200-KSPS, 4-/8-CHANNEL
SERIAL ANALOG-TO-DIGITAL CONVERTERS WITH ±10-V INPUTS

SLAS262C – OCTOBER 2000 – REVISED MAY 2003

operation cycle timing (continued)

After the operation finished, the host has several choices. Table 3 summarizes of operation options.

Table 3. Operation Options

MODE	CONVERSION IS INITIATED BY		
	\overline{CS}	FS	\overline{CSTART}
00	<ol style="list-style-type: none"> 1. Issue new Select/Read operation to read data and start new conversion. 2. Reconfigure the device. 	<ol style="list-style-type: none"> 1. Issue new Select/Read operation to read data and start new conversion. 2. Reconfigure the device. 	<ol style="list-style-type: none"> 1. Issue new \overline{CSTART} to start next conversion; old data lost. 2. Issue new Select/Read operation to read data—Issue new \overline{CSTART} to start new conversion. 3. Reconfigure the device.
01	<ol style="list-style-type: none"> 1. Read FIFO—Select Channel—Start new conversion. Channel must be selected after FIFO READ. 2. Select Channel—Start new conversion (old data lost) 3. Configure device again. 	<ol style="list-style-type: none"> 1. Read FIFO—Select Channel—Start new conversion. Channel must be selected after FIFO READ. 2. Select Channel—Start new conversion (old data lost) 3. Configure device again. 	<ol style="list-style-type: none"> 1. Read FIFO—Select channel—Start new conversion. Channel must be selected after FIFO READ. 2. Start new conversion (old data lost) with existing setting. 3. Configure device again.
10	<ol style="list-style-type: none"> 1. Read FIFO—Start new conversion with existing setting. 2. Configure device—New conversion (old data lost) 	<ol style="list-style-type: none"> 1. Read FIFO—Start new conversion with existing setting. 2. Configure device—New conversion (old data lost) 	<ol style="list-style-type: none"> 1. Read FIFO—Arm Period—Start new conversion with existing setting 2. Configure device—Arm Period—New conversion (old data lost)
11	<ol style="list-style-type: none"> 1. Read FIFO—Start new conversion with existing setting. 2. Start new conversion with the existing setting. 3. Configure device—Start new conversion with new setting. 	<ol style="list-style-type: none"> 1. Read FIFO—Start new conversion with existing setting 2. Start new conversion with the existing setting. 3. Configure Device—Start new conversion with new setting. 	<ol style="list-style-type: none"> 1. Read FIFO—Arm Period—Start new Conversion with existing setting 2. Start new conversion with existing setting. (old data lost) 3. Configure device—Arm Period—New conversion with new setting.

operation timing diagrams

The nonconversion operation includes FIFO READ and WRITE CFR. Both do not perform a conversion. The conversion operation performs one of four types of conversion: mode 00, 01, 10 and 11

write cycle (WRITE CFR Command): Write cycle does not generate EOC or \overline{INT} , nor does it carry out any conversion.

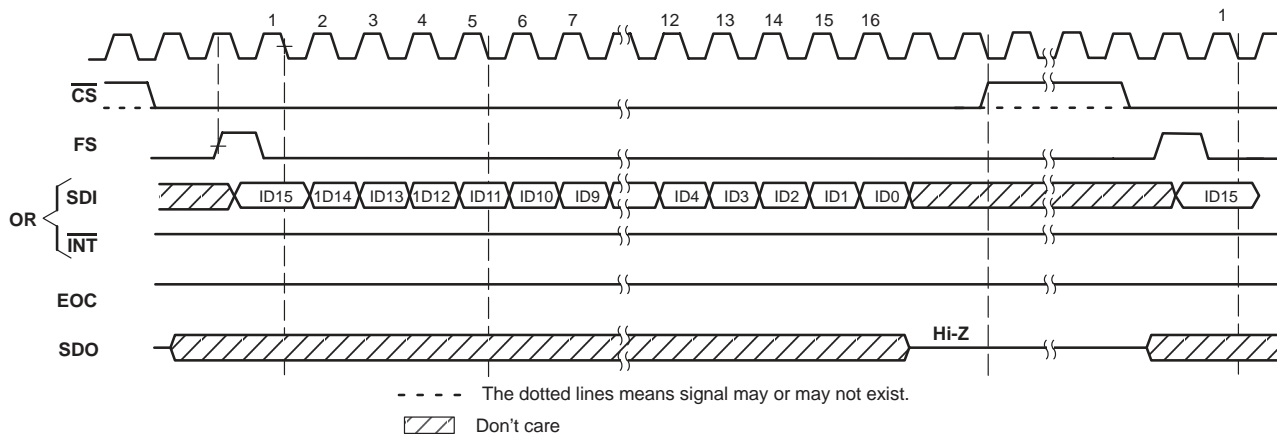

Figure 8. Write Cycle, FS Initiates Operation



operation timing diagrams (continued)

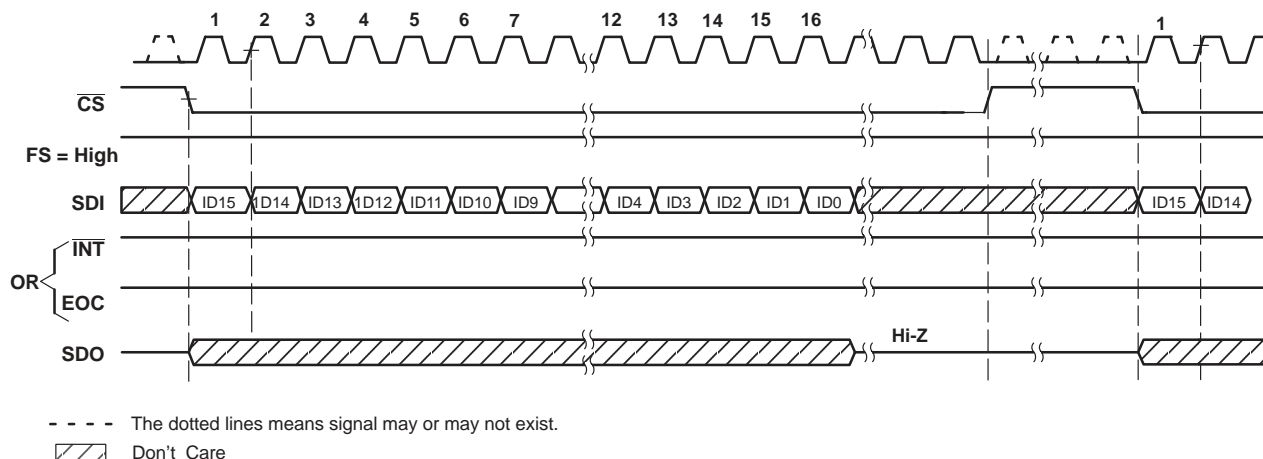

Figure 9. Write Cycle, \overline{CS} Initiates Operation, FS = 1

FIFO READ Operation: When the FIFO is used, the first command after \overline{INT} is generated is assumed to be the FIFO READ. The first FIFO content is output immediately before the command is decoded. If this command is not *FIFO READ*, the output is terminated. Using more layers of FIFO reduces the time taken to read multiple conversion results, because the read cycle does not generate an EOC or \overline{INT} , nor does it make a data conversion. Once the FIFO is read, the entire contents in FIFO must be read out. Otherwise, the remaining data is lost.

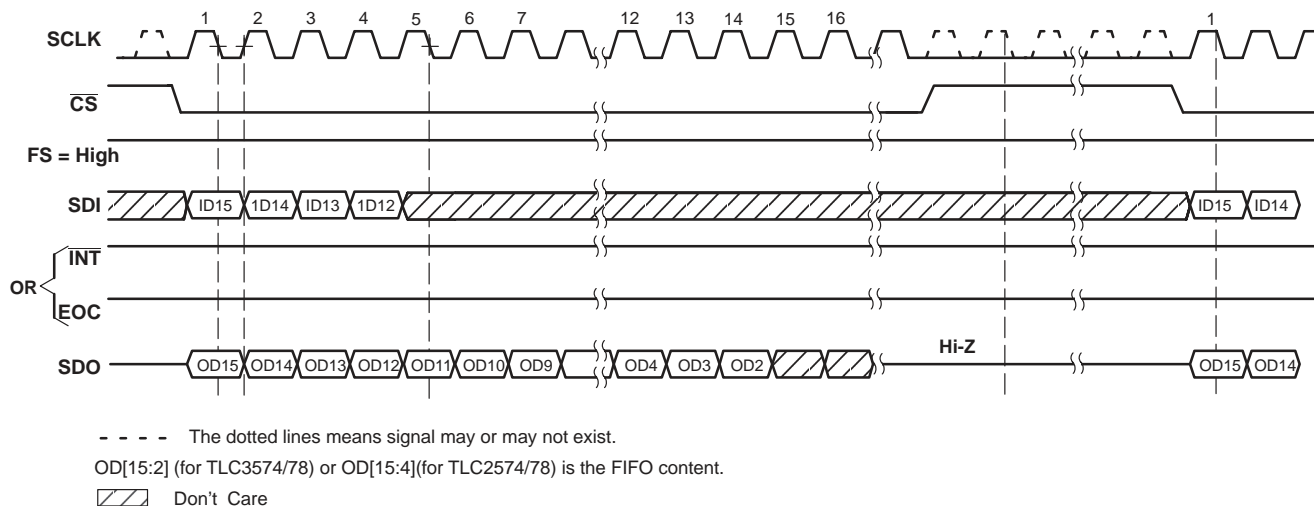

Figure 10. FIFO Read Cycle, \overline{CS} Initiates Operation, FS = 1

TLC3574, TLC3578, TLC2574, TLC2578
5-V ANALOG, 3-/5-V DIGITAL, 14-/12-BIT, 200-KSPS, 4-/8-CHANNEL
SERIAL ANALOG-TO-DIGITAL CONVERTERS WITH ± 10 -V INPUTS

SLAS262C – OCTOBER 2000 – REVISED MAY 2003

conversion operation

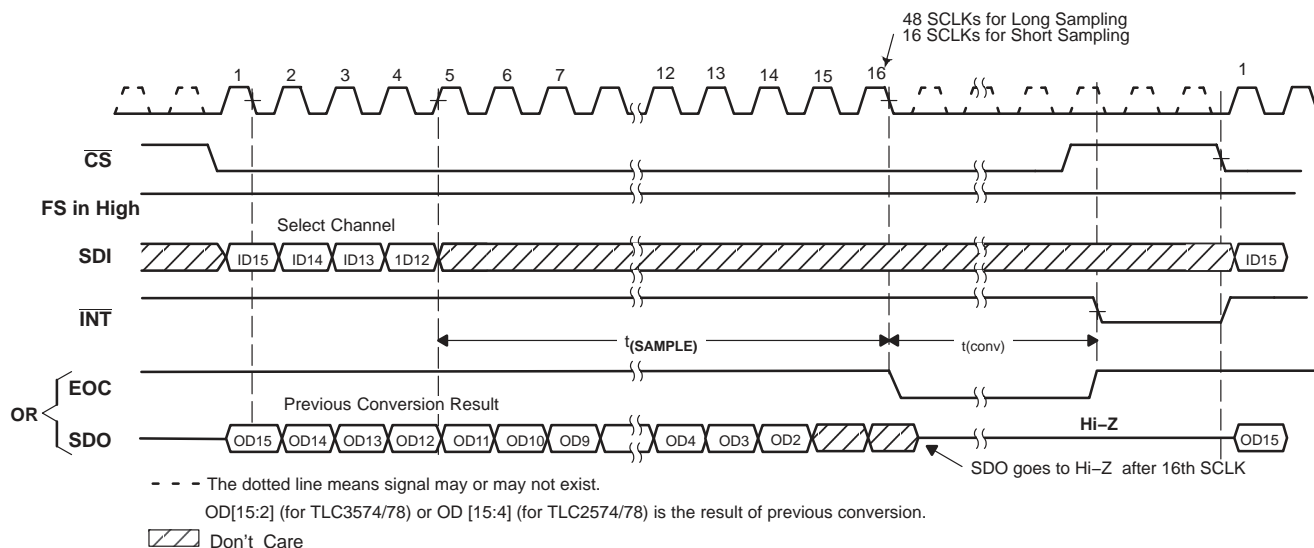

Figure 11. Mode 00, $\overline{\text{CS}}$ Initiates Operation

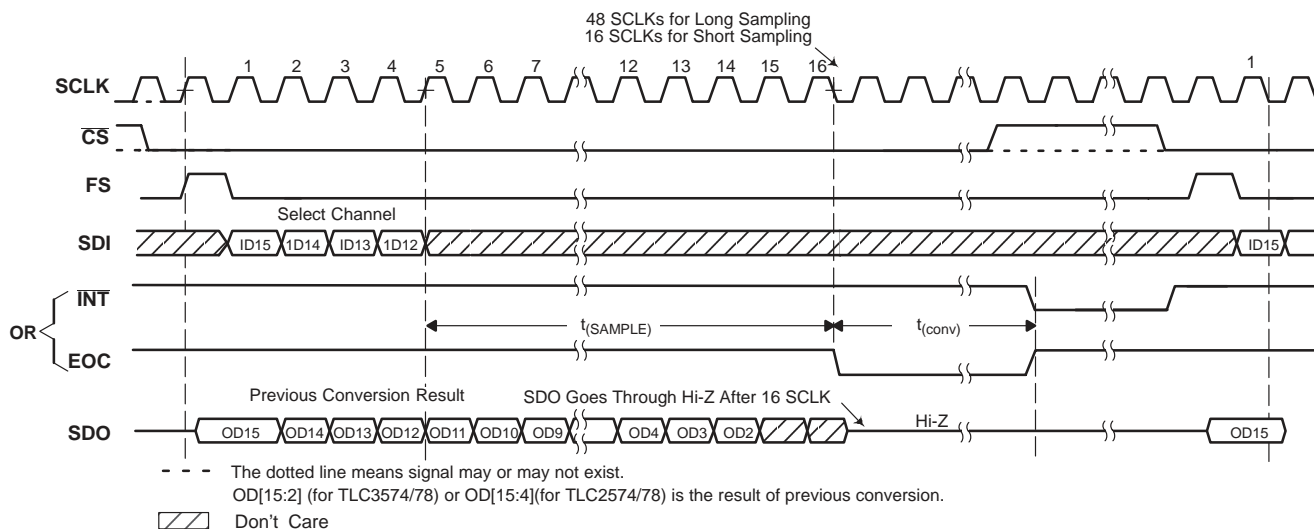

Figure 12. Mode 00, FS Initiates Operation

TLC3574, TLC3578, TLC2574, TLC2578
5-V ANALOG, 3-/5-V DIGITAL, 14-/12-BIT, 200-KSPS, 4-/8-CHANNEL
SERIAL ANALOG-TO-DIGITAL CONVERTERS WITH ± 10 -V INPUTS

SLAS262C – OCTOBER 2000 – REVISED MAY 2003

conversion operation (continued)

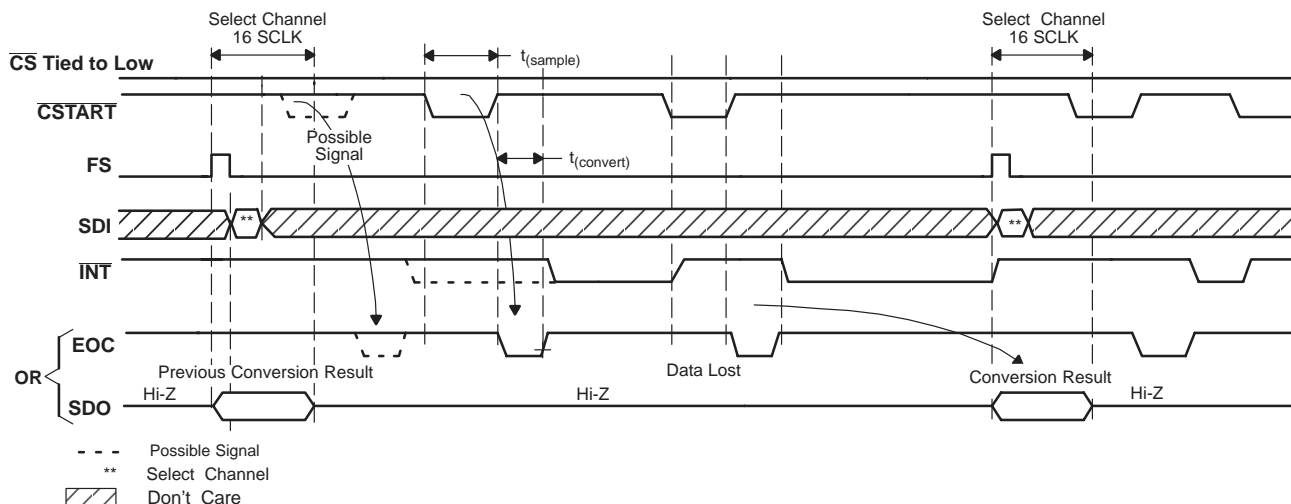

Figure 13. Mode 00, CSTART Triggers Sampling/Conversion, FS Initiates Select

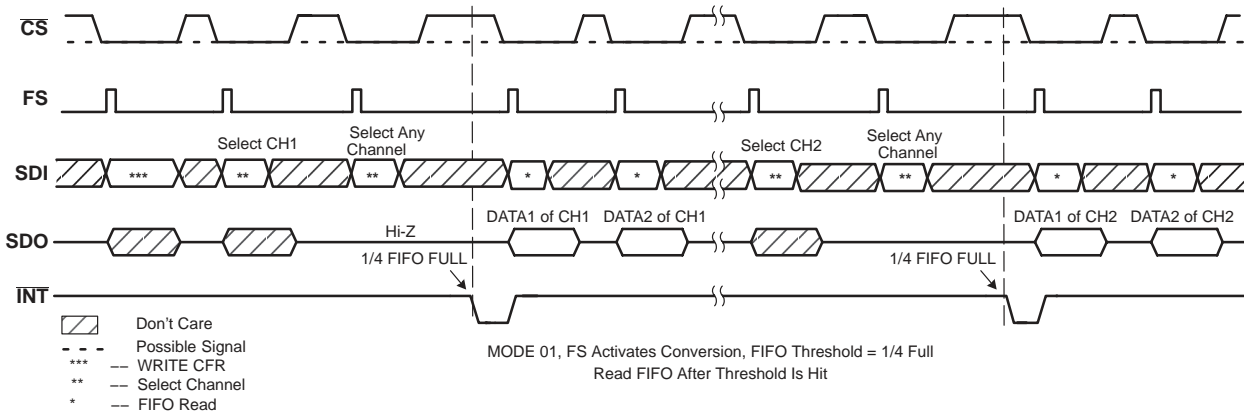

Figure 14. Mode 01, FS Initiates Operations

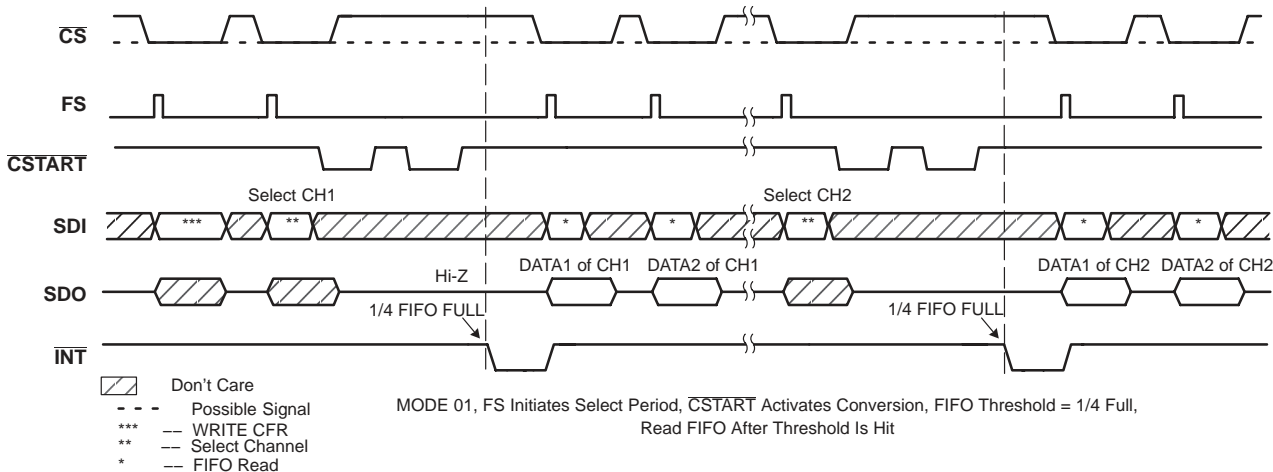

Figure 15. Mode 01, CSTART Triggers Samplings/Conversions

TLC3574, TLC3578, TLC2574, TLC2578
5-V ANALOG, 3-5-V DIGITAL, 14-/12-BIT, 200-KSPS, 4-/8-CHANNEL
SERIAL ANALOG-TO-DIGITAL CONVERTERS WITH ± 10 -V INPUTS

SLAS262C – OCTOBER 2000 – REVISED MAY 2003

conversion operation (continued)

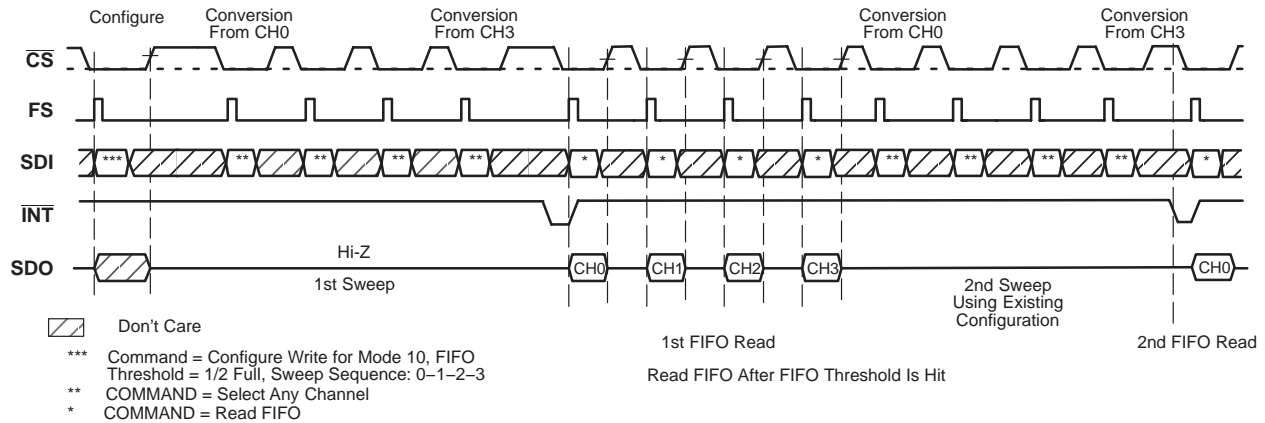

Figure 16. Mode 10, FS Initiates Operations

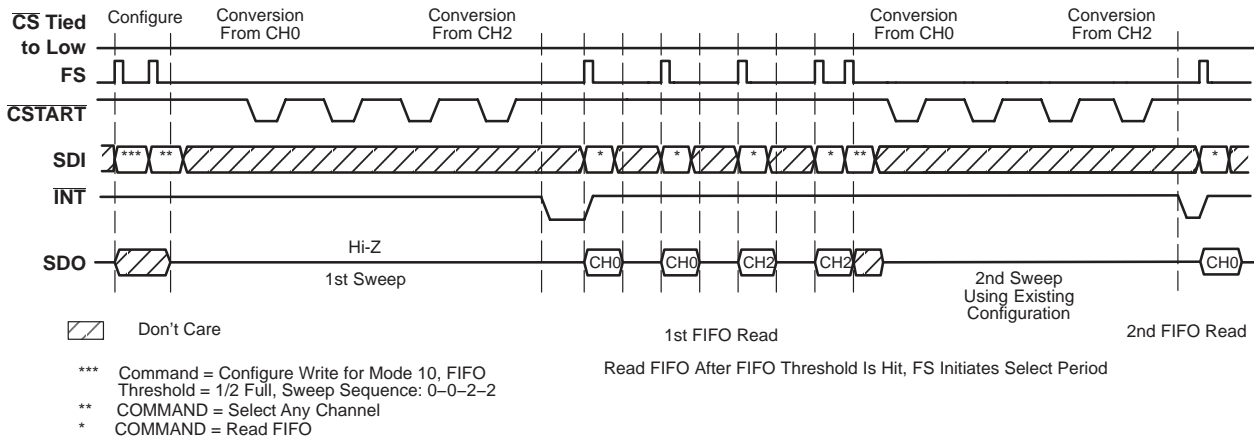

Figure 17. Mode 10, CSTART Initiates Operations

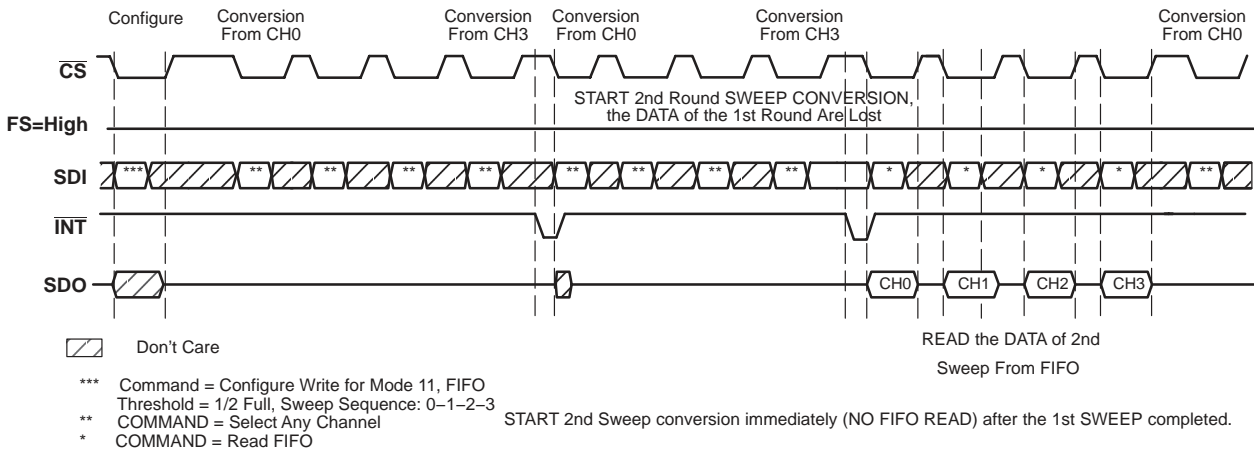

Figure 18. Mode 11, CS Initiates Operations

TLC3574, TLC3578, TLC2574, TLC2578
5-V ANALOG, 3-/5-V DIGITAL, 14-/12-BIT, 200-KSPS, 4-/8-CHANNEL
SERIAL ANALOG-TO-DIGITAL CONVERTERS WITH ± 10 -V INPUTS

SLAS262C – OCTOBER 2000 – REVISED MAY 2003

conversion operation (continued)

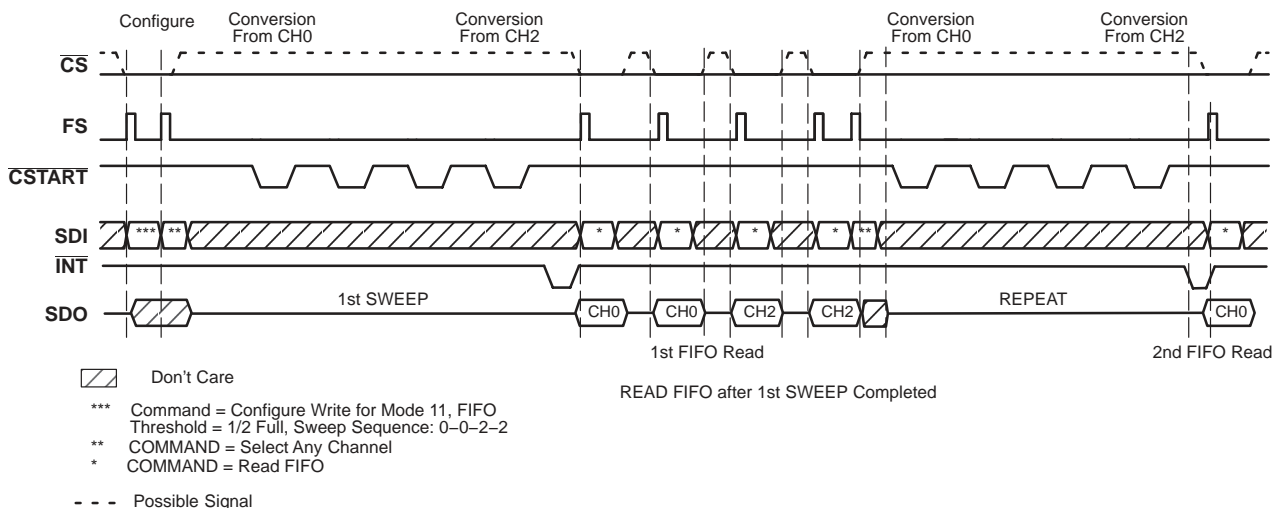

Figure 19. Mode 11, $\overline{\text{CSTART}}$ Triggers Samplings/Conversions, FS Initiates SELECT Operation

conversion clock and conversion speed

The conversion clock source can be the internal OSC, or the external clock, SCLK. The conversion clock is equal to the internal OSC if the internal clock is used, or equal to SCLK/4 when the external clock is selected. It takes 18 conversion clocks plus 15 ns to finish the conversion for TLC3574 and TLC3578, and 13 conversion clocks plus 15 ns for the TLC2574 and TLC2578. If the external clock is selected, the conversion time (not including sampling time) is $18X(4/f_{\text{SCLK}})+15$ ns for TLC3574 and TLC3578 and $13X(4/f_{\text{SCLK}})+15$ ns for TLC2574 and TLC2578. Table 4 shows the maximum conversion rate (including sampling time) when the analog input source resistor is 25 Ω .

Table 4. Maximum Conversion Rate

DEVICE	SAMPLING MODE	CONVERSION CLK	MAX SCLK (MHz)	CONVERSION TIME (μs)	RATE (KSPS)
TLC3574/78 ($R_s = 25 \Omega$)	SHORT (16 SCLK)	External SCLK/4	10	8.815	113.4
	LONG (48 SCLK)	External SCLK/4	25	4.815	207.7
	SHORT (16 SCLK)	Internal 6.5 MHz	10	4.384	228.0
	LONG (48 SCLK)	Internal 6.5 MHz	25	4.705	212.5
TLC2574/78 ($R_s = 25 \Omega$)	SHORT (16 SCLK)	External SCLK/4	10	6.815	146.7
	LONG (48 SCLK)	External SCLK/4	25	4.015	249.1
	SHORT (16 SCLK)	Internal 6.5 MHz	10	3.615	276.6
	LONG (48 SCLK)	Internal 6.5 MHz	25	3.935	254.1

TLC3574, TLC3578, TLC2574, TLC2578 5-V ANALOG, 3-/5-V DIGITAL, 14-/12-BIT, 200-KSPS, 4-/8-CHANNEL SERIAL ANALOG-TO-DIGITAL CONVERTERS WITH ± 10 -V INPUTS

SLAS262C – OCTOBER 2000 – REVISED MAY 2003

FIFO operation

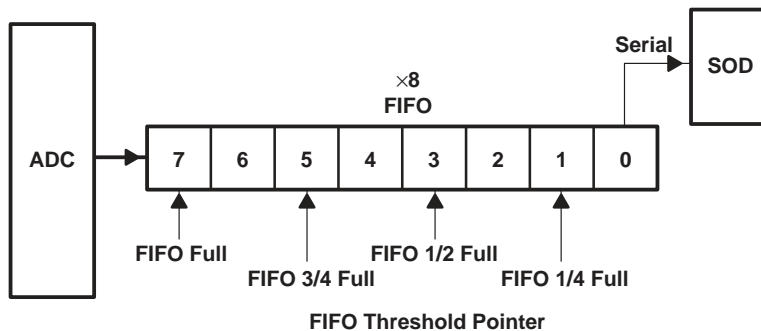

Figure 20. FIFO Structure

FIFO operation (continued)

The device has an 8-level FIFO that can be programmed for different thresholds. An interrupt is sent to the host after the preprogrammed threshold is reached. The FIFO is used to store conversion results in mode 01, 10, and 11, from either a fixed channel or a series of channels according to the preprogrammed sweep sequence. For example, an application may require eight measurements from channel 3. In this case, if the threshold is set to full, the FIFO is filled with 8 data conversions sequentially taken from channel 3. Another application may require data from channel 0, 2, 4, and 6 in that order. The threshold is set to 1/2 full and sweep sequence is selected as 0–2–4–6–0–2–4–6. An interrupt is sent to the host as soon as all four data conversions are in the FIFO. FIFO is reset after power on and WRITE CFR operation. The contents of the FIFO are retained during autopower down.

Autopower-Down Mode: The device enters the autopower-down state at the end of conversion. The power current is about 20 μ A if SCLK stops, and 120 μ A maximum if SCLK is running. Active \overline{CS} , FS, or \overline{CSTART} resumes the device from power-down state. The bipolar input current is not turned off when device is in power-down mode.

The configuration register is not affected by the power-down mode but the SWEEP operation sequence must be started over again. All FIFO contents are retained in power-down mode.

TYPICAL CHARACTERISTICS

INTEGRAL NONLINEARITY
vs
DIGITAL OUTPUT CODE

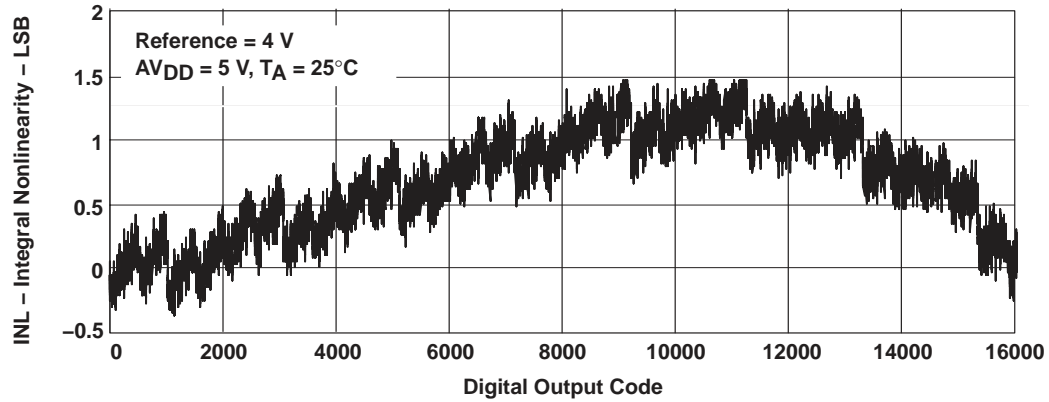

Figure 21

DIFFERENTIAL NONLINEARITY
vs
DIGITAL OUTPUT CODE

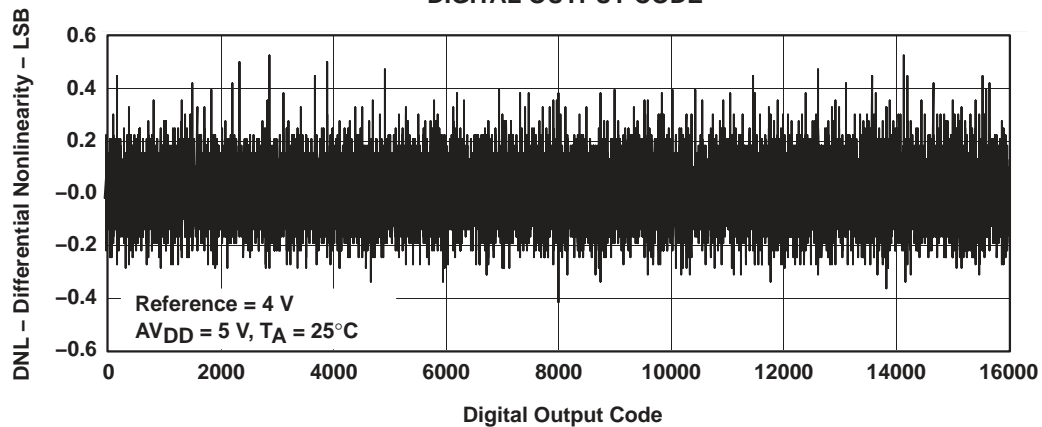

Figure 22

TLC3574, TLC3578, TLC2574, TLC2578
5-V ANALOG, 3-/5-V DIGITAL, 14-/12-BIT, 200-KSPS, 4-/8-CHANNEL
SERIAL ANALOG-TO-DIGITAL CONVERTERS WITH ± 10 -V INPUTS

SLAS262C – OCTOBER 2000 – REVISED MAY 2003

TYPICAL CHARACTERISTICS

INL (LSB) AND DNL (LSB)
vs
FREE-AIR TEMPERATURE

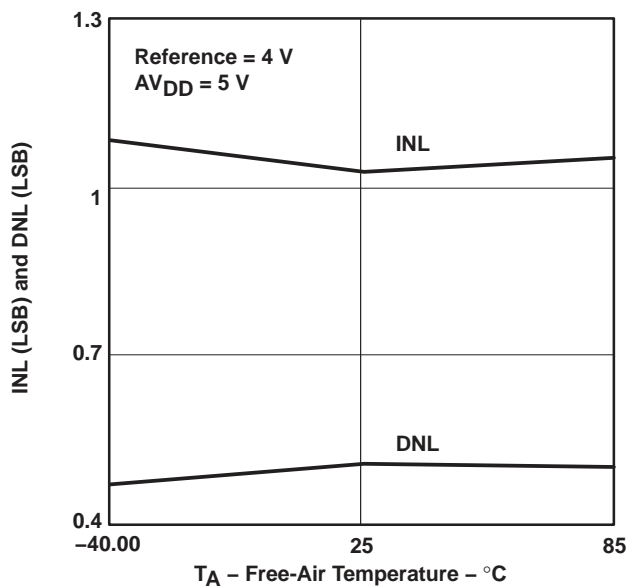

Figure 23

BIPOLAR ZERO ERROR, POSITIVE FULL SCALE ERROR
AND NEGATIVE FULL SCALE ERROR (% FS)
vs
FREE-AIR TEMPERATURE

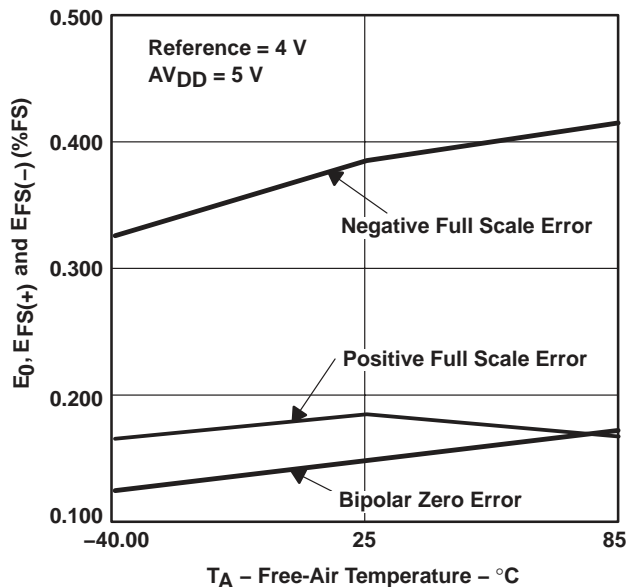

Figure 24

FFT OF SNR (dB)

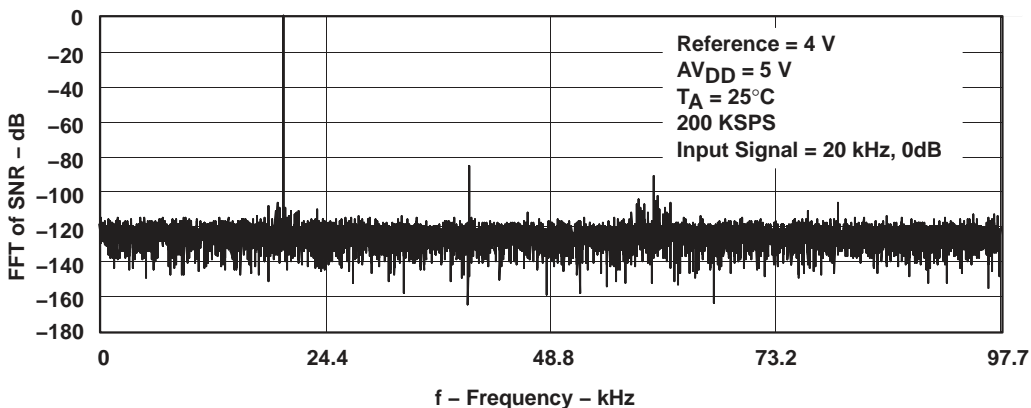

Figure 25

TYPICAL CHARACTERISTICS

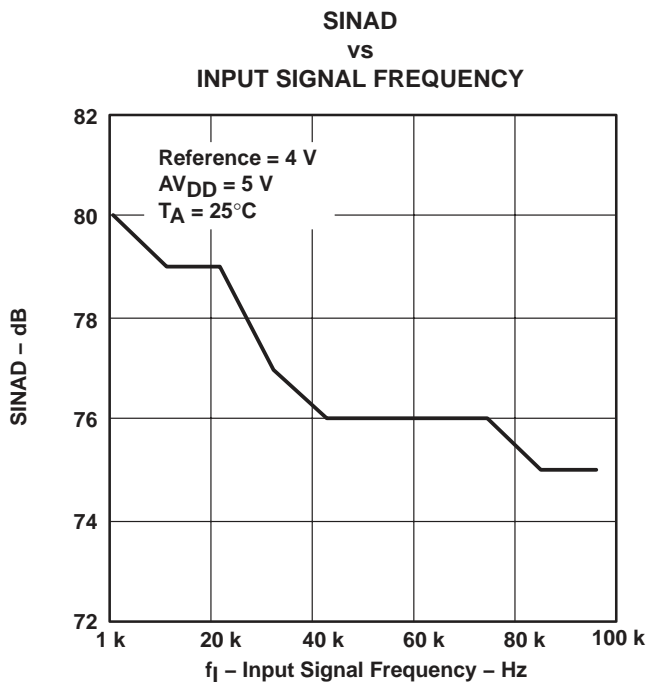

Figure 26

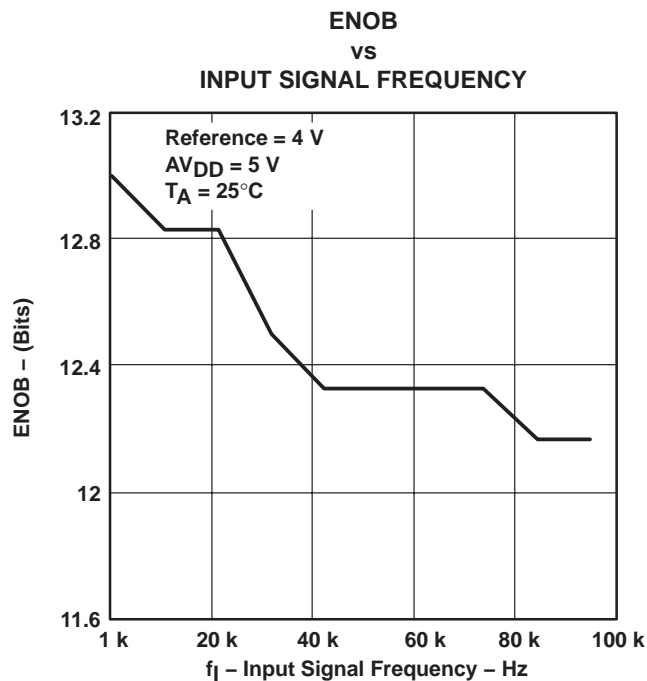

Figure 27

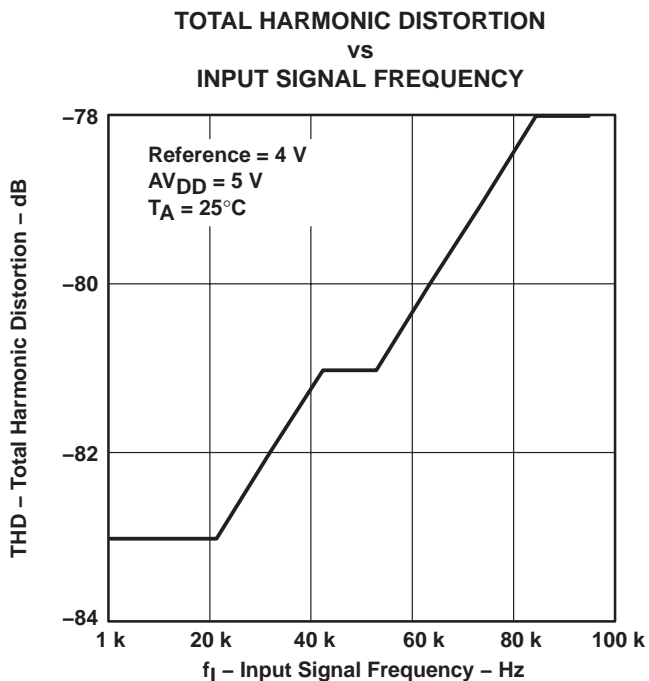

Figure 28

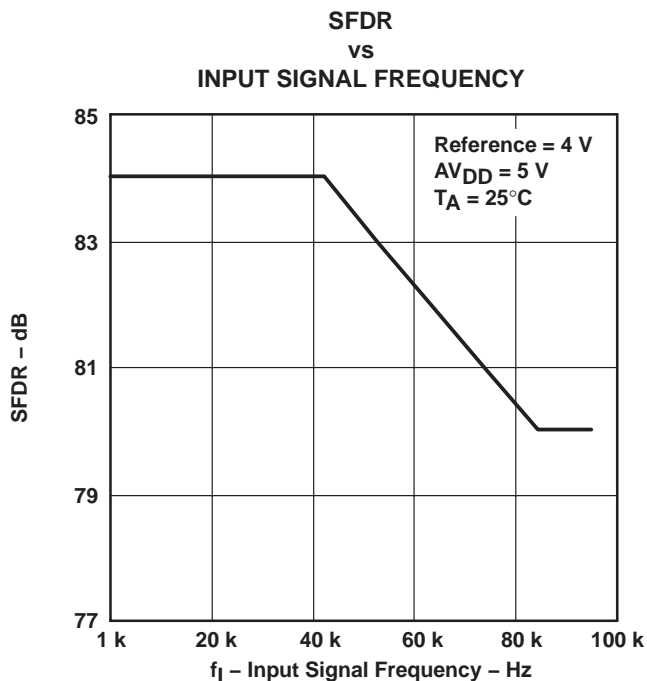

Figure 29

TYPICAL CHARACTERISTICS

**SUPPLY CURRENT
 vs
 FREE-AIR TEMPERATURE**

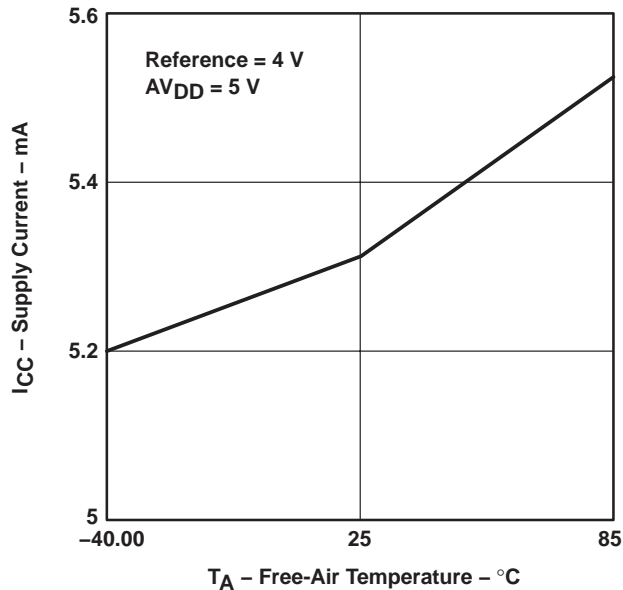

Figure 30

**SUPPLY CURRENT AT AUTOPOWER DOWN
 vs
 FREE-AIR TEMPERATURE**

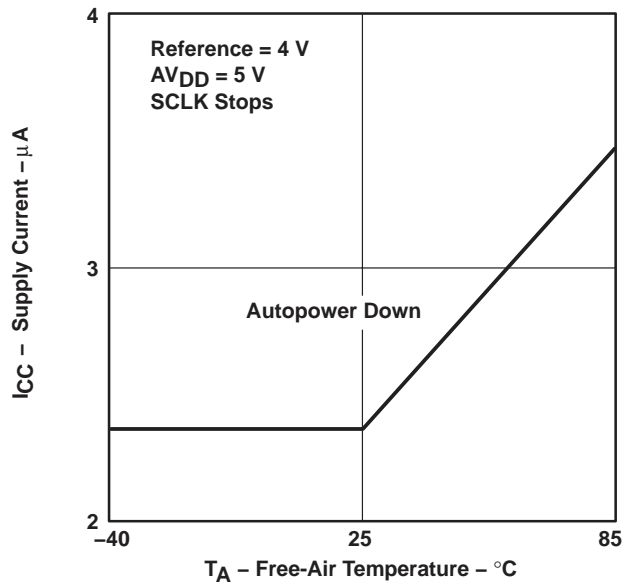

Figure 31

APPLICATION INFORMATION

interface with host

Figure 32 shows the examples of the interface between a single converter and host DSP (TMS320C54x™ DSP) or microprocessor. The C54x is set as FWID=1 (active pulse width=1CLK); (R/X) DATDLY=1 (1 bit data delay); CLK(X/R)P=0 (transmit data are clocked out at rising edge of CLK, receive data are sampled on falling edge of CLK); and FS(X/R)P=1 (FS is active high). If multiple converters connect to the same C54x, use \overline{CS} as chip select.

The host microprocessor is set as the SPI master, CPOL=0 (active high clock), and CPHA=1 (transmit data is clock out at rising edge of CLK, receive data are sampled at falling edge of CLK). 16 bits (or more) per transfer is required.

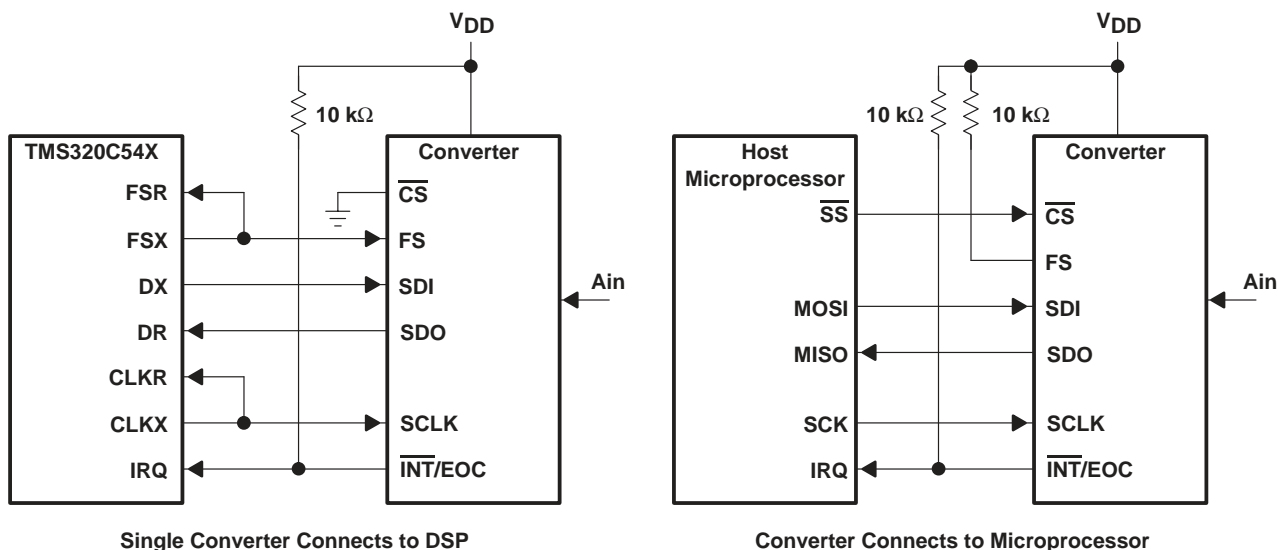

Figure 32. Typical Interface to Host DSP and Microprocessor

sampling time analysis

Figure 33 shows the equivalent circuit to evaluate the required sampling time. Req is the Thevenin equivalent resistor (Req = 3.5 K). The C_(sampling) is sampling capacitor (30 pF maximum).

To get 1/4 LSB accuracy, the sampling capacitor, C_{sampling}, has to be charged to

$$V_C = V_S \pm \text{voltage of } 1/4 \text{ LSB} = V_S \pm (V_S/65532) \text{ for 14 bit converter (TLC3574 and TLC3578)}$$

$$= V_S \pm (V_S/16384) \text{ for 12 bit converter (TLC2574 and TLC2578)}$$

During the sampling time t_(sampling), C_(sampling) is charge to

$$V_C = V_S \left[1 - \exp \left(\frac{-t_{(\text{sampling})}}{\text{Req} \times C_{(\text{sampling})}} \right) \right]$$

Therefore, the required sampling time is

$$t_{(\text{sampling})} = \text{Req} \times C_{(\text{sampling})} \times \ln(65532) \text{ for 14-bit (TLC3574 and TLC3578)}$$

$$t_{(\text{sampling})} = \text{Req} \times C_{(\text{sampling})} \times \ln(16384) \text{ for 12-bit (TLC2574 and TLC2578)}$$

TMS320C54x is a trademark of Texas Instruments.

TLC3574, TLC3578, TLC2574, TLC2578
5-V ANALOG, 3-/5-V DIGITAL, 14-/12-BIT, 200-KSPS, 4-/8-CHANNEL
SERIAL ANALOG-TO-DIGITAL CONVERTERS WITH ± 10 -V INPUTS

SLAS262C – OCTOBER 2000 – REVISED MAY 2003

APPLICATION INFORMATION

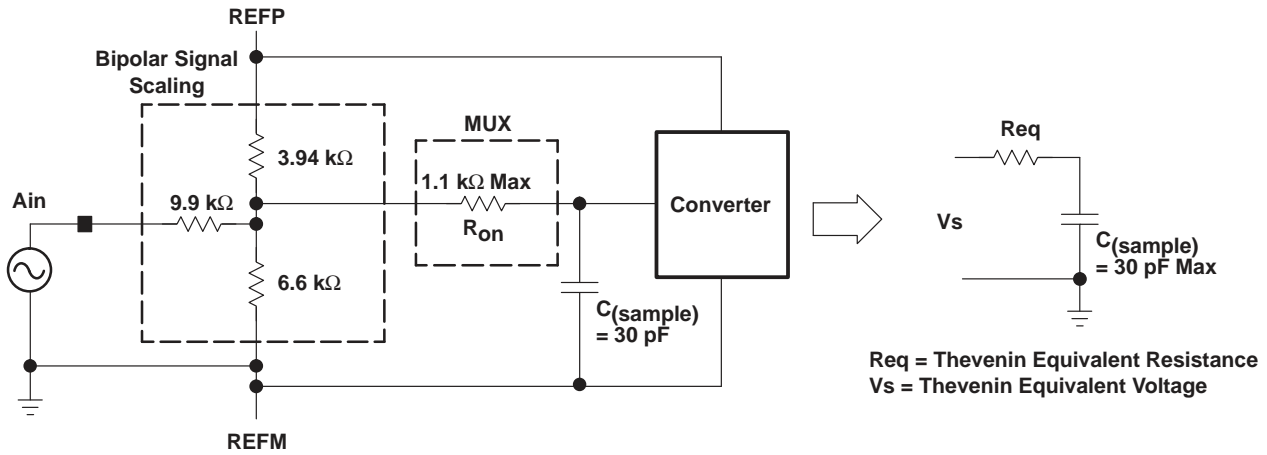

Figure 33. Equivalent Input Circuit Including the Driving Source

IMPORTANT NOTICE

Texas Instruments Incorporated and its subsidiaries (TI) reserve the right to make corrections, modifications, enhancements, improvements, and other changes to its products and services at any time and to discontinue any product or service without notice. Customers should obtain the latest relevant information before placing orders and should verify that such information is current and complete. All products are sold subject to TI's terms and conditions of sale supplied at the time of order acknowledgment.

TI warrants performance of its hardware products to the specifications applicable at the time of sale in accordance with TI's standard warranty. Testing and other quality control techniques are used to the extent TI deems necessary to support this warranty. Except where mandated by government requirements, testing of all parameters of each product is not necessarily performed.

TI assumes no liability for applications assistance or customer product design. Customers are responsible for their products and applications using TI components. To minimize the risks associated with customer products and applications, customers should provide adequate design and operating safeguards.

TI does not warrant or represent that any license, either express or implied, is granted under any TI patent right, copyright, mask work right, or other TI intellectual property right relating to any combination, machine, or process in which TI products or services are used. Information published by TI regarding third-party products or services does not constitute a license from TI to use such products or services or a warranty or endorsement thereof. Use of such information may require a license from a third party under the patents or other intellectual property of the third party, or a license from TI under the patents or other intellectual property of TI.

Reproduction of information in TI data books or data sheets is permissible only if reproduction is without alteration and is accompanied by all associated warranties, conditions, limitations, and notices. Reproduction of this information with alteration is an unfair and deceptive business practice. TI is not responsible or liable for such altered documentation.

Resale of TI products or services with statements different from or beyond the parameters stated by TI for that product or service voids all express and any implied warranties for the associated TI product or service and is an unfair and deceptive business practice. TI is not responsible or liable for any such statements.

Following are URLs where you can obtain information on other Texas Instruments products and application solutions:

Products		Applications	
Amplifiers	amplifier.ti.com	Audio	www.ti.com/audio
Data Converters	dataconverter.ti.com	Automotive	www.ti.com/automotive
DSP	dsp.ti.com	Broadband	www.ti.com/broadband
Interface	interface.ti.com	Digital Control	www.ti.com/digitalcontrol
Logic	logic.ti.com	Military	www.ti.com/military
Power Mgmt	power.ti.com	Optical Networking	www.ti.com/opticalnetwork
Microcontrollers	microcontroller.ti.com	Security	www.ti.com/security
		Telephony	www.ti.com/telephony
		Video & Imaging	www.ti.com/video
		Wireless	www.ti.com/wireless

Mailing Address: Texas Instruments
Post Office Box 655303 Dallas, Texas 75265