

THIS DRAWING IS UNPUBLISHED. RELEASED FOR PUBLICATION
 © COPYRIGHT BY TYCO ELECTRONICS CORPORATION. ALL RIGHTS RESERVED.

LOC	DIST	REVISIONS			
P	LTR	DESCRIPTION	DATE	DWN	APVD
CM	00	F	REV PER ECN 0G3B-0514-03	11AUG03	SC CJ

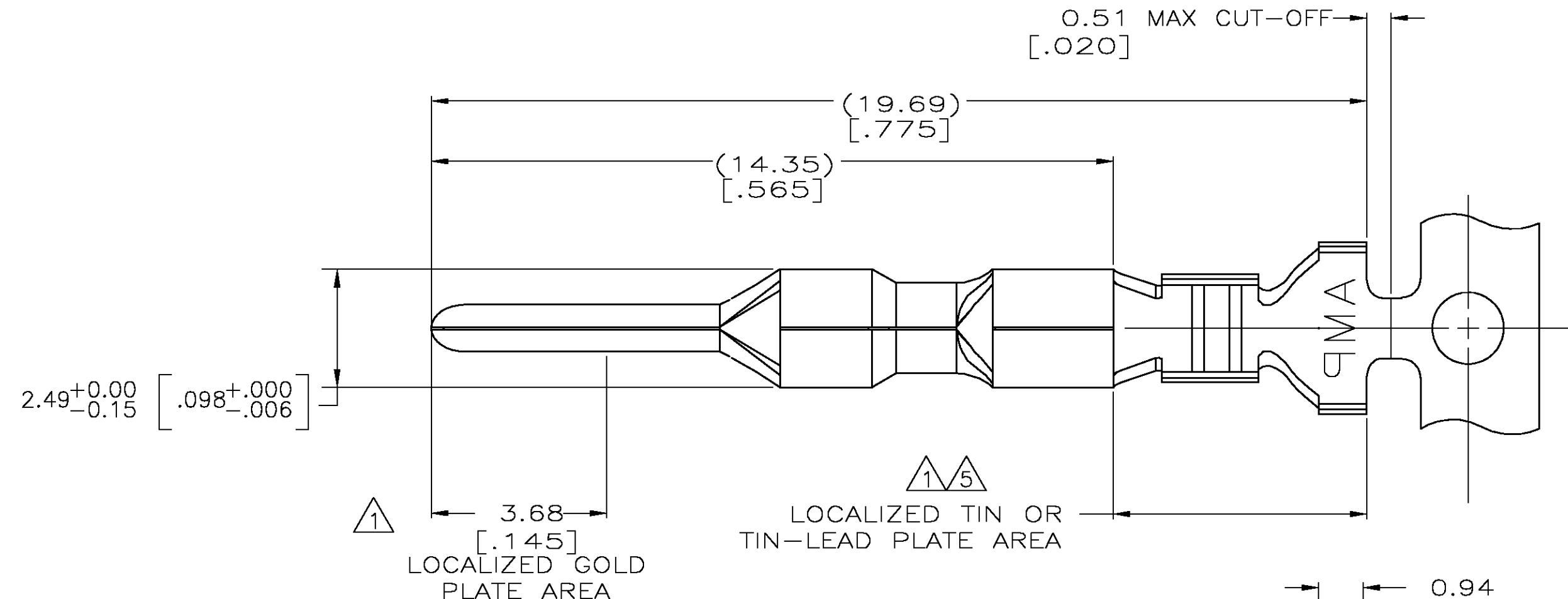

- 1. 0.00076 [.000030] MIN GOLD IN LOCALIZED GOLD PLATE AREA AND 0.00254 [.000100] MIN BRIGHT TIN-LEAD IN LOCALIZED TIN-LEAD PLATE AREA OVER 0.0013 [.000050] MIN NICKEL.
- 2. WIRE RANGE: 0.3 - 0.9MM² (22-18 AWG).
- 3. INSULATION RANGE: 1.50-2.39 [.059-.094] DIA.
- 4. DIMENSIONS IN BRACKETS ARE IN INCHES.
- 5. 0.00076 [.000030] MIN GOLD IN LOCALIZED GOLD PLATE AREA AND 0.00254 [.000100] MIN BRIGHT TIN IN LOCALIZED TIN PLATE AREA OVER 0.0013 [.000050] MIN NICKEL.

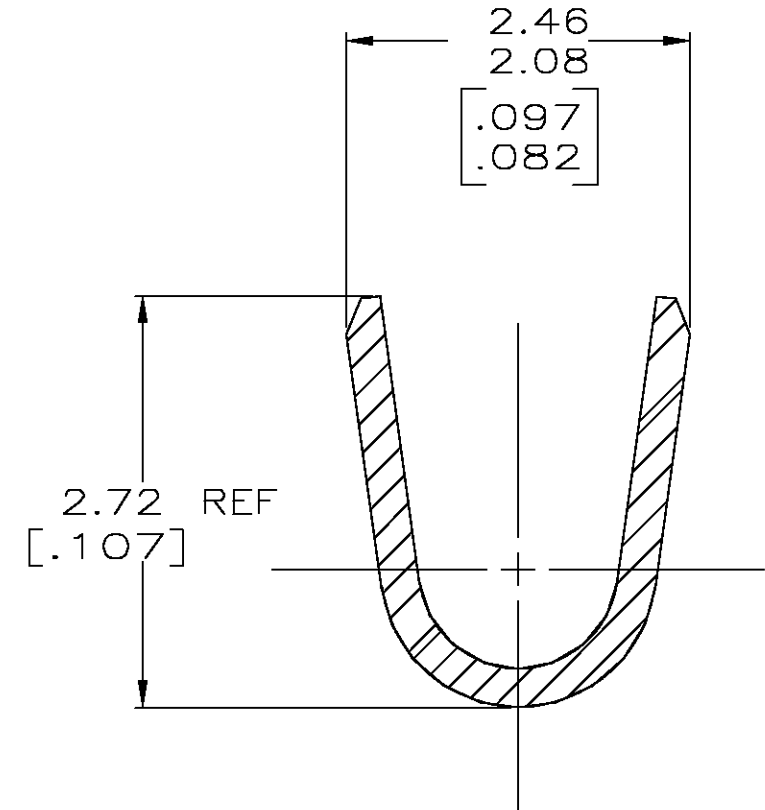
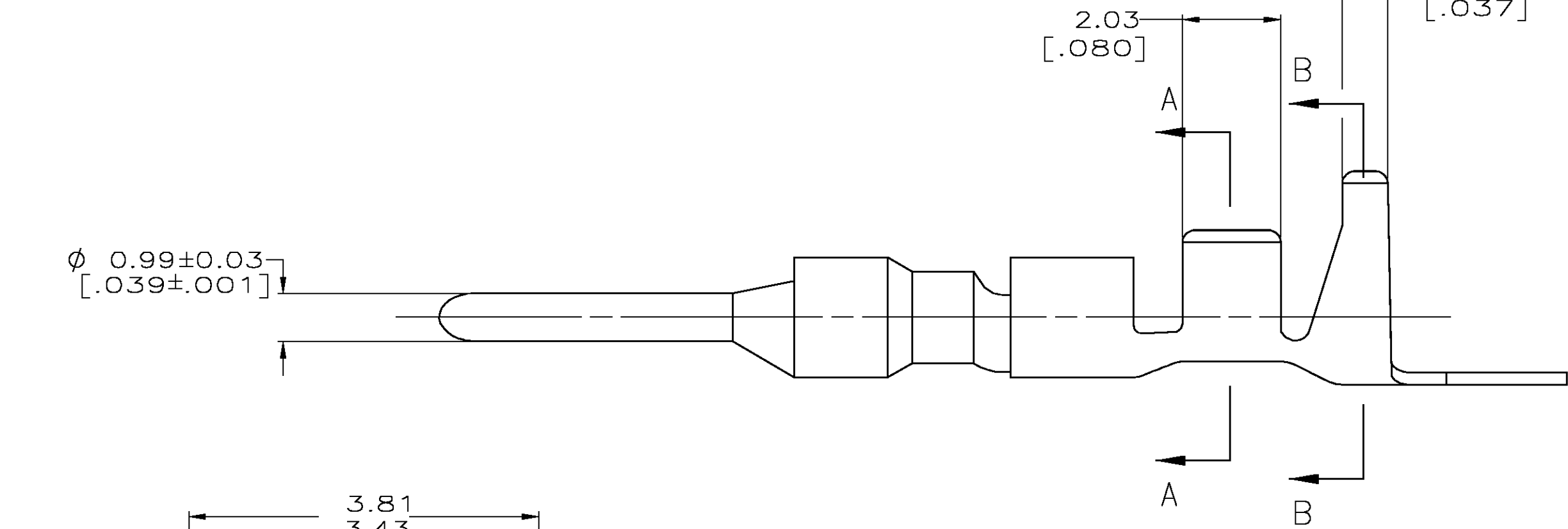

SECTION A-A
SCALE 20:1

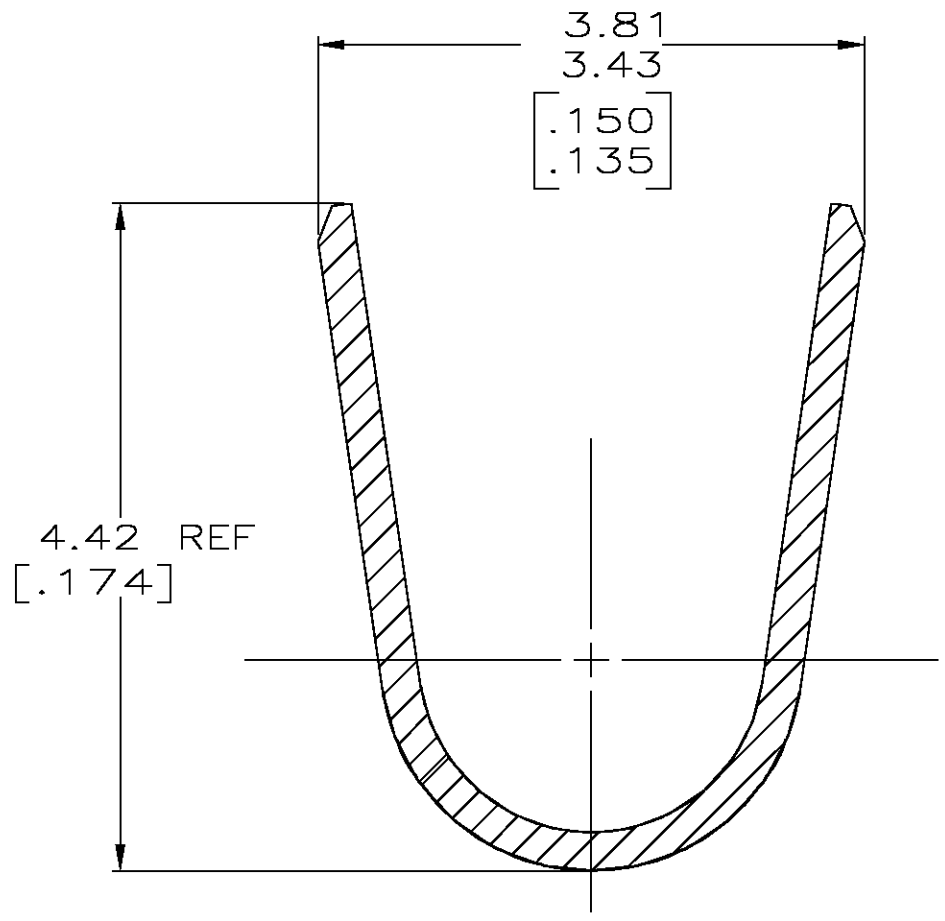

SECTION B-B
SCALE 20:1

FINISH	MATERIAL	PART NUMBER
GOLD 5	0.25 [.010] BRASS	1-794220-0
GOLD 1	0.25 [.010] BRASS	794220-3
PRE-TIN	0.25 [.010] BRASS	794220-1

THIS DRAWING IS A CONTROLLED DOCUMENT.		DWN S. CARPENTER 11AUG2003	Tyco Electronics Corporation Harrisburg, PA 17105	
DIMENSIONS: INCHES		CHK C. JONES 11AUG2003		
TOLERANCES UNLESS OTHERWISE SPECIFIED:		APVD C. JONES 11AUG2003	NAME PIN, MINI UNIVERSAL MATE-N-LOK 2	
0 PLC ±		PRODUCT SPEC	SIZE A2	
1 PLC ±		APPLICATION SPEC	CAGE CODE 00779	
2 PLC ±		WEIGHT	DRAWING NO G=794220	
3 PLC ± 0.15 [.006]		CUSTOMER DRAWING	RESTRICTED TO -	
4 PLC ±		SCALE 10:1	SHEET 1 OF 1	
ANGLES ±			REV F	
FINISH				
SEE TABLE				

794220