

4 3 2 1 used for: D-SUB

POS.	A ^{-0.76}	B ^{-0.25}	C	Part-NO.
9	31.19	16.46	25.00 ^{+0.12} / _{-0.13}	DSS1XSXXG04X
15	39.52	24.79	33.30 ^{+0.15} / _{-0.1}	DSS2XSXXG04X
25	53.42	38.50	47.04 ±0.13	DSS3XSXXG04X
37	69.70	54.96	63.50 ±0.13	DSS4XSXXG04X

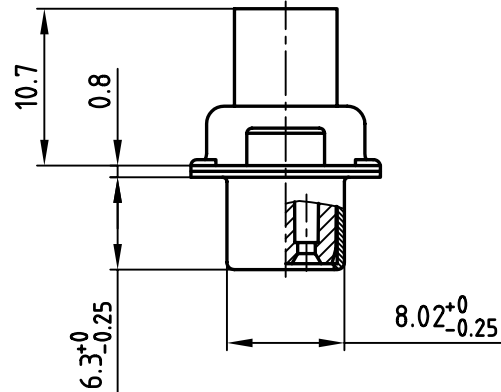
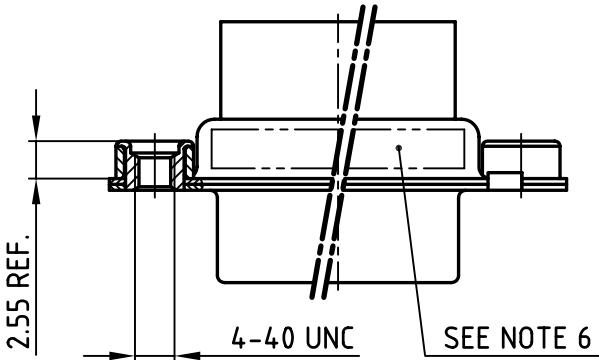
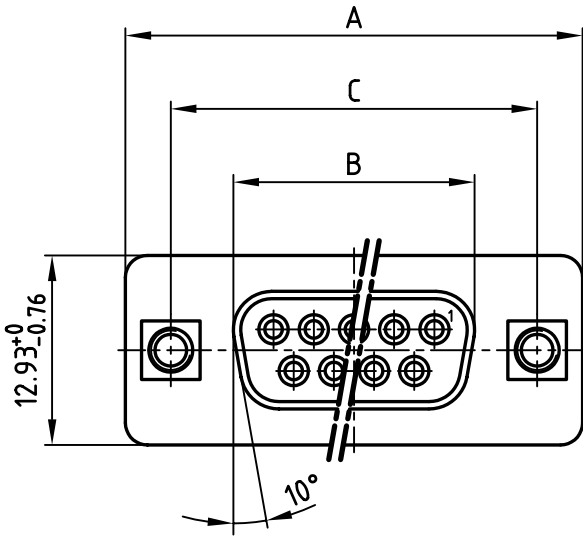

Directive 2002/95/EC
"RoHS"
Compliant

NOTES:

1. METAL SHELLS: STEEL; min. 315µm TIN over 40-80µm NICKEL
2. INSULATORS: PBT GF UL 94 V-0, BLACK
3. THREADED INSERT: COPPER ALLOY; min. 200µm TIN over 80µm NICKEL
4. COLLAR: COPPER ALLOY; min. 200µm TIN over 80µm NICKEL
5. MAXIMUM TORQUE VALUE FOR THREAD: 6 in.LB
6. CONNECTOR IS PART MARKED: PART-NO. CONEC ABC

APPROVAL # FREIGABE # DEBLOCAGE # AUTORIZACION # APPROVAL	
CUSTOMER APPROVAL DATE:	
NAME:	TITLE:
COMPANY NAME:	
APPROVAL # FREIGABE # DEBLOCAGE # AUTORIZACION # APPROVAL	

THIS DRAWING MAY NOT BE COPIED OR REPRODUCED IN ANY WAY, AND MAY NOT BE PASSED ON TO A THIRD PARTY WITHOUT WRITTEN PERMISSION.
 OWNERSHIP AND COPYRIGHT OF CONEC GmbH
 DO NOT ALTER CAD DRAWING BY HAND

tolerance		 dim. in mm
2005	date	
drawn	03.05	name
appd.	03.05.	Kühle
norm	DIN 41652	
d-old		
1 x b	Ä 2542	02.08.2006 Lehmen
a	Origin	
rev.	description	date name



scale:	2:1	
material:	SEE NOTES	
title:	D-SUB FEMALE 9-37pos. CRIMP STYLE with threaded insert	
dwg no:	AutoCAD 2004	DIN-A
	16K1A1392	4
part no:	SEE TABLE	
		sh: 1/1

4 3 2 1