

6

5

4

3

2

1

APPROVED: _____

DATE: _____ TITLE: _____

Rev	AWO #	Description	Date	Appr
-		RELEASED	8/11/16	

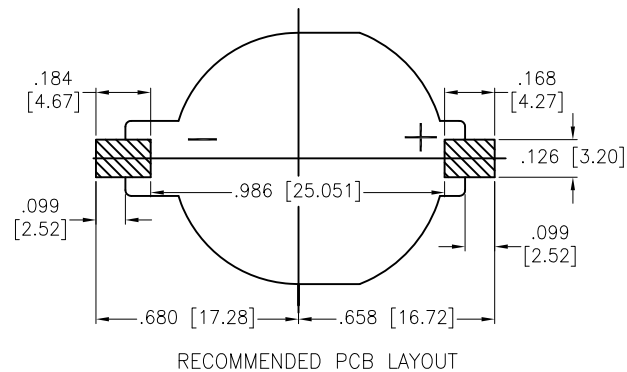
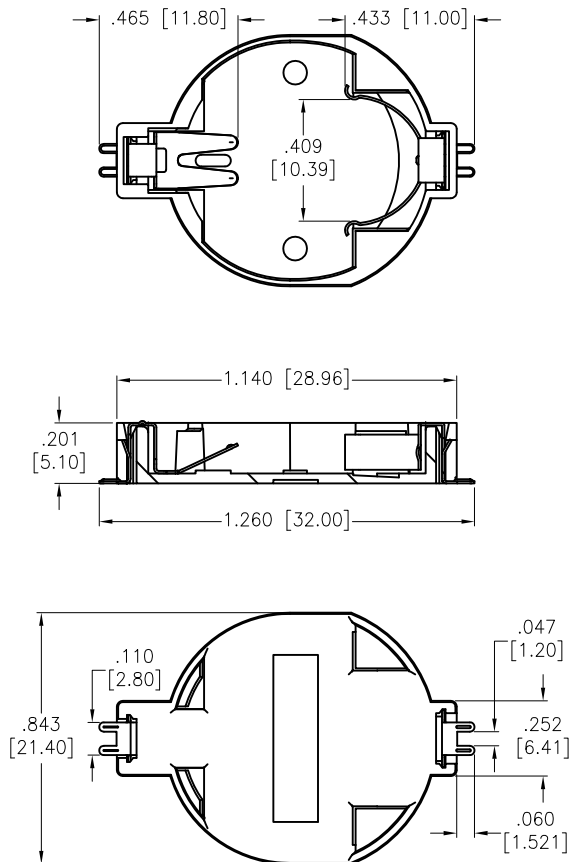

SPECIFICATIONS:

Material:
Housing: Hi-temp thermoplastic (PPS), rated UL94V-0, Color: Brown
Contact: Phosphor Bronze, Gold plated
Electrical:
Contact resistance: 30 mohms max
Insulation resistance: 1,000 Mohms min
Dielectric Voltage: 500 VAC one sec level
Temperature Rating:
Operating temperature: -25°C to +85°C.
Environmental:
Lead free, RoHS compliant



UNLESS OTHERWISE SPECIFIED ALL DIMENSIONS ARE INCHES [MM] TOLERANCES: EXCEPT AS NOTED		ADAM TECH 909 Rahway Avenue, Union, NJ 07083 Phone: 908-687-5000 Fax: 908-687-5710	
INCHES HOLES			
.X ± .10	Ø.X ± .10	TITLE BATTERY HOLDER, SURFACE MOUNT, FOR CR2032, BROWN COLOR	
.XX ± .020	Ø.XX ± .015		
.XXX ± .015	Ø.XXX ± .010		
APPROVALS		DATE	
DRAWN	HR	8/11/16	
CHECKED	LW	8/11/16	
APPROVED			
SIZE X	PART NO. BH-92-5	REV. -	
REF: S00136C	SCALE: NTS	SHEET 1 OF 1	

6

5

4

3

2

1