

NOTES:

- 1. MATERIALS OF CONSTRUCTION:
 SHELL, BODY/FLANGE, & CONTACT BODY = BRASS, NICKEL PLATED
 CONTACT PIN = BRASS, GOLD PLATED
 RETAINER RING = STAINLESS STEEL, NATURAL
 INSULATOR = TEFLON PER MIL-P-19468
 GASKET = SILICONE RUBBER, COLOR RED

49000-RFX		REVISIONS		
DRAWING NO.	REV	DESCRIPTION	DATE	ECO
THIRD ANGLE PROJ.	A	RELEASE TO MFG.	11/28/00	43603
				CPM

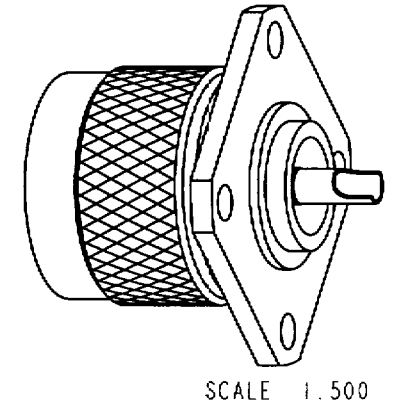
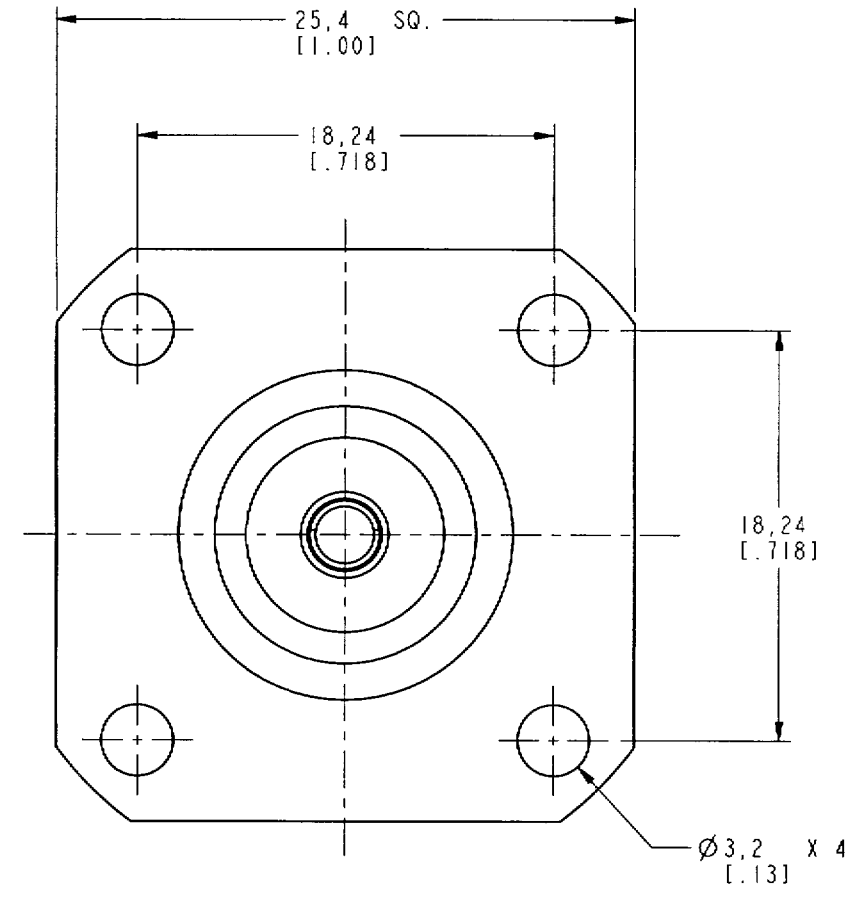
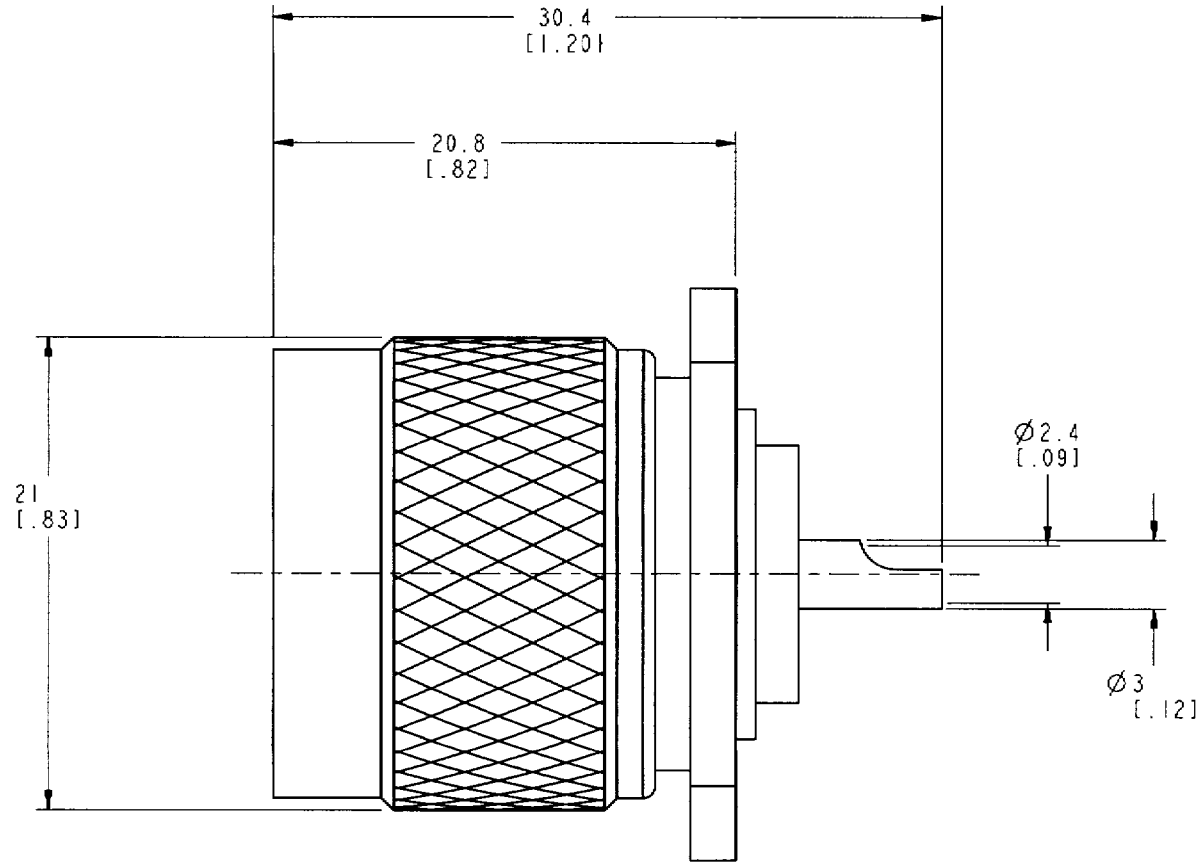

CUSTOMER OUTLINE DRAWING
FOR REFERENCE ONLY

UNLESS OTHERWISE SPECIFIED, DIMENSIONS ARE IN INCHES AND TOLERANCES ARE: 0.5 - 6mm ±0.2mm 6 - 30mm ±0.4mm 30 - 120mm ±0.6mm	MATERIAL	DRAWN C. McGRATH	DATE 11/14/00	TITLE 'N' PANEL RECEPTACLE PLUG	Amphenol Amphenol Corporation Communication and Network Products Division Danbury, CT U.S.A. 06810		
	REFERENCE GEN# 49000-SRFX_ASSY	ENGINEER T. AUBIN	DATE 11/14/00			SCALE: 3.0:1 SHEET 2 OF 2	
NOTICE - These drawings, specifications, or other data (1) are, and remain the property of Amphenol Corp. (2) must be returned upon request; and (3) are confidential and not to be disclosed to any person other than those to whom they are given by Amphenol Corp. The furnishing of these drawings, specifications, or other data by Amphenol Corp. or to any other person to anyone for any purpose is not to be regarded by implication or otherwise in any manner licensing, granting rights or permitting such holder or any other person to manufacture, use or sell any product, process or design, patented or otherwise, that may in any way be related to or disclosed by said drawings, specifications, or other data.		APPROVED <i>[Signature]</i>	DATE 11/28/00	CODE ID 74868	DWG SIZE B	DRAWING NO. 49000-RFX	REV A