

DO NOT SCALE FROM THIS PRINT

IPBS-1XX-XX-XX-D-XX

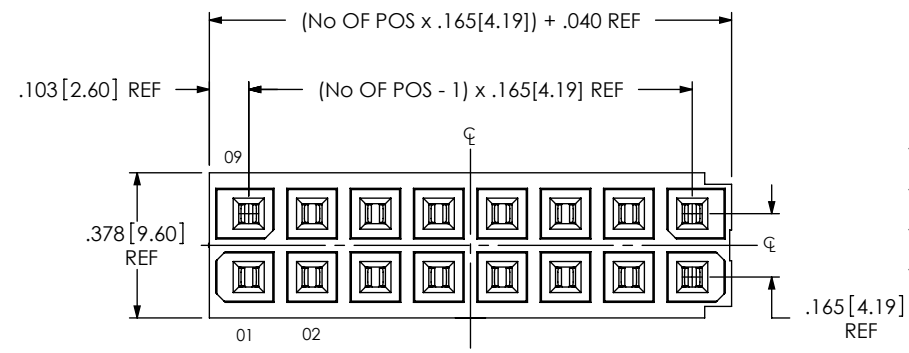

No OF POSITIONS
-02 THRU -15
(PER ROW)

OPTION
-GP: GUIDE POSTS
(USE IPBS-XX-D-GP)
(SEE FIG. 3, SHT 2)

LEAD STYLE

- 01: STANDARD POWER, THROUGH HOLE (USE C-168-01-SP-XX) (SEE FIG. 1)
- 02: STANDARD POWER, SURFACE MOUNT (USE C-168-02-SP-XX) (SEE FIG. 2, SHEET 2)
- H1: HIGH POWER, THROUGH HOLE (USE C-168-01-HP-XX) (SEE FIG. 1) (SEE NOTE 10)
- H2: HIGH POWER, SURFACE MOUNT (USE C-168-02-HP-XX) (SEE FIG. 2, SHEET 2) (SEE NOTE 10)

ROW SPECIFICATION
-D: DOUBLE (USE IPBS-XX-D)

PLATING SPECIFICATION

- T: TIN (USE C-168-XX-XX-T)
- TM: MATTE TIN (USE C-168-XX-XX-T)

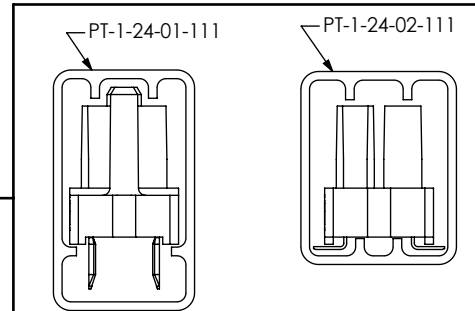
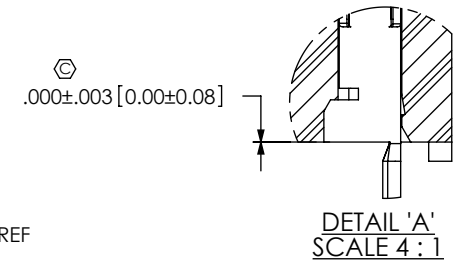
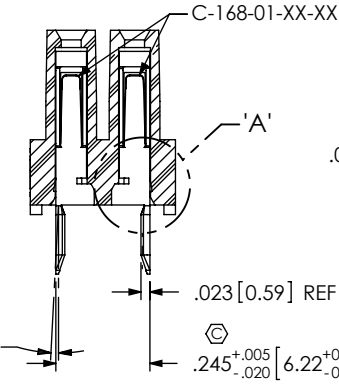
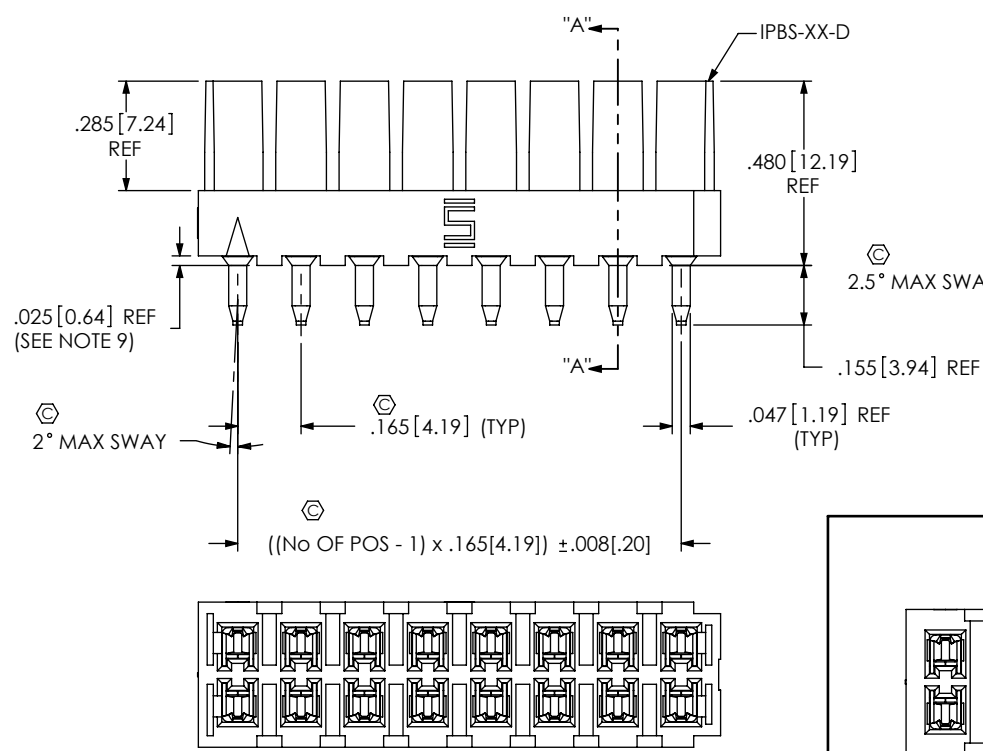

NOTE: PARTS TO BE LOADED WITH POSITION #1 IN SAME DIRECTION AS ARROW ON TUBE

TABLE 2		
LEAD / OPTION	PACKAGING TUBE	PLUG
-X1, -X1-GP	PT-1-24-01-111	TP-13
-X2, -X2-GP	PT-1-24-02-111	TP-13

FIG 1
IPBS-108-X1-XX-D SHOWN

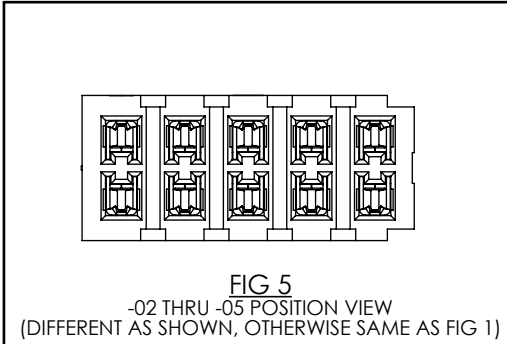

UNLESS OTHERWISE SPECIFIED, DIMENSIONS ARE IN INCHES.
TOLERANCES ARE:
DECIMALS ANGLES
.XX: ±.01 [.3] 2°
.XXX: ±.005 [.13]
.XXXX: ±.0020 [.051]

PROPRIETARY NOTE
THIS DOCUMENT CONTAINS CONFIDENTIAL AND PROPRIETARY INFORMATION AND ALL DESIGN, MANUFACTURING, REPRODUCTION, USE, PATENT RIGHTS AND SALES RIGHTS ARE EXPRESSLY RESERVED BY SAMTEC, INC. THIS DOCUMENT SHALL NOT BE DISCLOSED, IN WHOLE OR PART, TO ANY UNAUTHORIZED PERSON OR ENTITY NOR REPRODUCED, TRANSFERRED OR INCORPORATED IN ANY OTHER PROJECT IN ANY MANNER WITHOUT THE EXPRESS WRITTEN CONSENT OF SAMTEC, INC.

MATERIAL: DO NOT SCALE DRAWING SHEET SCALE: 2:1
INSULATOR: LCP, COLOR: BLACK
CONTACT: PHOS BRONZE (-SP) or HIGH COPPER ALLOY (-HP)

DESCRIPTION:
.165[4.19] DOUBLE ROW SOCKET ASSEMBLY
DWG. NO. IPBS-1XX-XX-XX-D-XX
BY: KEVIN B 8/27/2001 SHEET 1 OF 2



520 PARK EAST BLVD, NEW ALBANY, IN 47150
PHONE: 812-944-6733 FAX: 812-948-5047
e-Mail: info@SAMTEC.com code: 53322

- NOTES:
1. Ⓢ REPRESENTS A CRITICAL DIMENSION.
 2. COPLANARITY (FOR -X2): SEE TABLE 1.
 3. BURR ALLOWANCE: .003[.08] MAX.
 4. PARTS TO BE MOLDED TO POSITION.
 5. MINIMUM PUSHOUT FORCE: 1 LB.
 6. MEASURED AT THE LOWEST POINT.
 7. ALL PIN TO PIN DIMENSIONS TO BE MEASURED FROM TIP TO TIP.
 8. THIS NUMBER REPRESENTS THE NUMBER OF POSITIONS PER ROW ONLY & IS NOT INTENDED TO BE USED IN POSITION NUMBERING. SEE FIG. 4
 9. TWO POSITION PART WILL HAVE STANDOFFS OPPOSITE GATE END.
 10. AVAILABLE TO EXISTING CUSTOMERS ONLY. DO NOT DESIGN IN AS OF REVISION J.

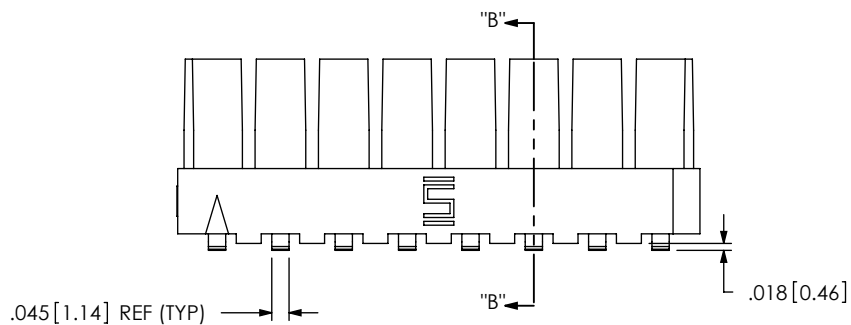
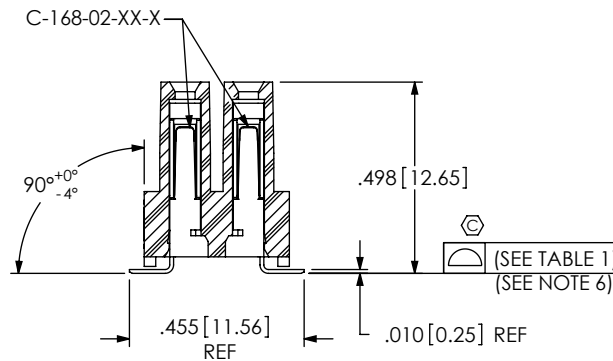

FIG 2
-X2: SURFACE MOUNT
IPBS-108-X2-X-D SHOWN
(DIFFERENT AS SHOWN, OTHERWISE SAME AS FIG 1)



SECTION "B"-"B"

TABLE 1	
NO OF POSITIONS	COPLANARITY
-02 THRU -08	.004[.10]
-09 THRU -15	.006[.15]

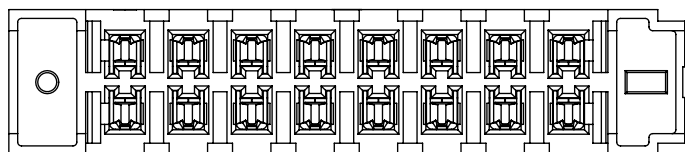
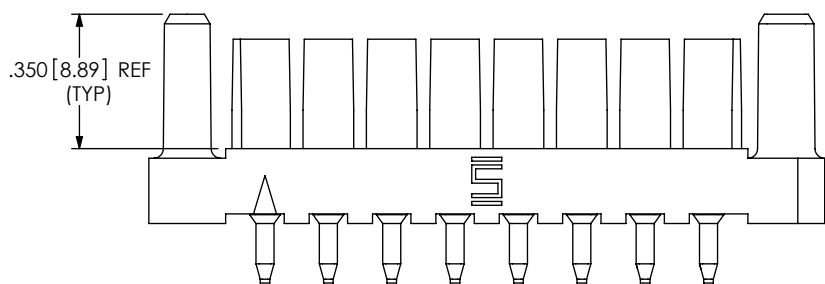
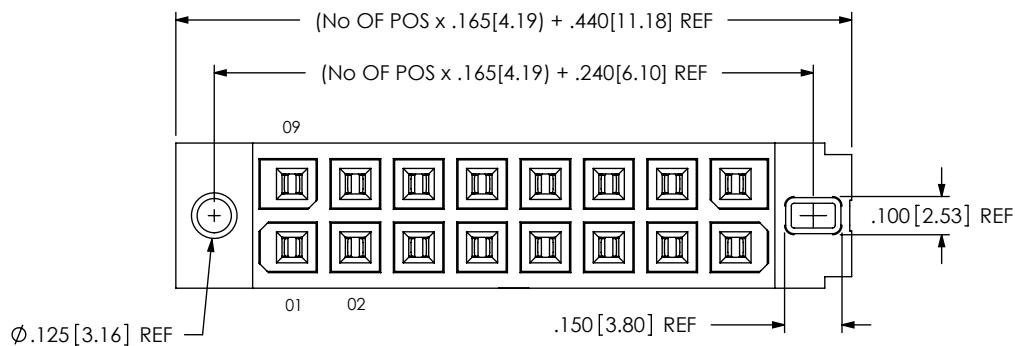

FIG 3
-GP: GUIDE POSTS
IPBS-108-X1-X-D-GP SHOWN
(DIFFERENT AS SHOWN, OTHERWISE SAME AS FIG 1)

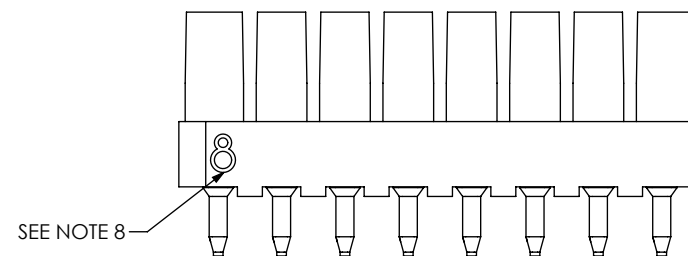

FIG 4

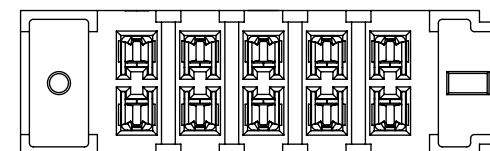

FIG 6
-GP: GUIDE POSTS
-02 THRU -05 POSITION VIEW
(DIFFERENT AS SHOWN, OTHERWISE SAME AS FIG 3)

PROPRIETARY NOTE
THIS DOCUMENT CONTAINS CONFIDENTIAL AND PROPRIETARY INFORMATION AND ALL DESIGN, MANUFACTURING, REPRODUCTION, USE, PATENT RIGHTS AND SALES RIGHTS ARE EXPRESSLY RESERVED BY SAMTEC, INC. THIS DOCUMENT SHALL NOT BE DISCLOSED, IN WHOLE OR PART, TO ANY UNAUTHORIZED PERSON OR ENTITY NOR REPRODUCED, TRANSFERRED OR INCORPORATED IN ANY OTHER PROJECT IN ANY MANNER WITHOUT THE EXPRESS WRITTEN CONSENT OF SAMTEC, INC.

DO NOT SCALE DRAWING
SHEET SCALE: 2:1

samtec

520 PARK EAST BLVD, NEW ALBANY, IN 47150
PHONE: 812-944-6733 FAX: 812-948-5047
e-Mail: info@SAMTEC.com code: 55322

DESCRIPTION:
.165[4.19] DOUBLE ROW SOCKET ASSEMBLY

DWG. NO.
IPBS-1XX-XX-XX-D-XX

BY: KEVIN B 8/27/2001 SHEET 2 OF 2