

THIS DRAWING IS UNPUBLISHED. RELEASED FOR PUBLICATION  
 © COPYRIGHT - By - ALL RIGHTS RESERVED.

REVISIONS					
P	LTR	DESCRIPTION	DATE	DWN	APVD
	AH	REVISED PER ECO-12-012320	04JUL12	KH	MZ
	AJ	REVISED PER ECO-17-009977	11JUL2017	RS	MZ

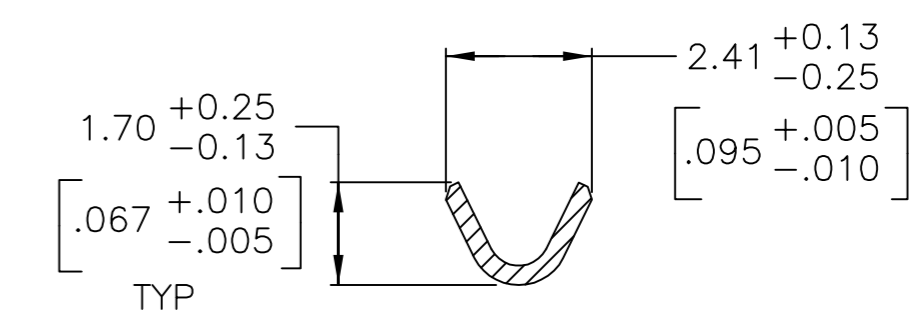

SECTION A-A

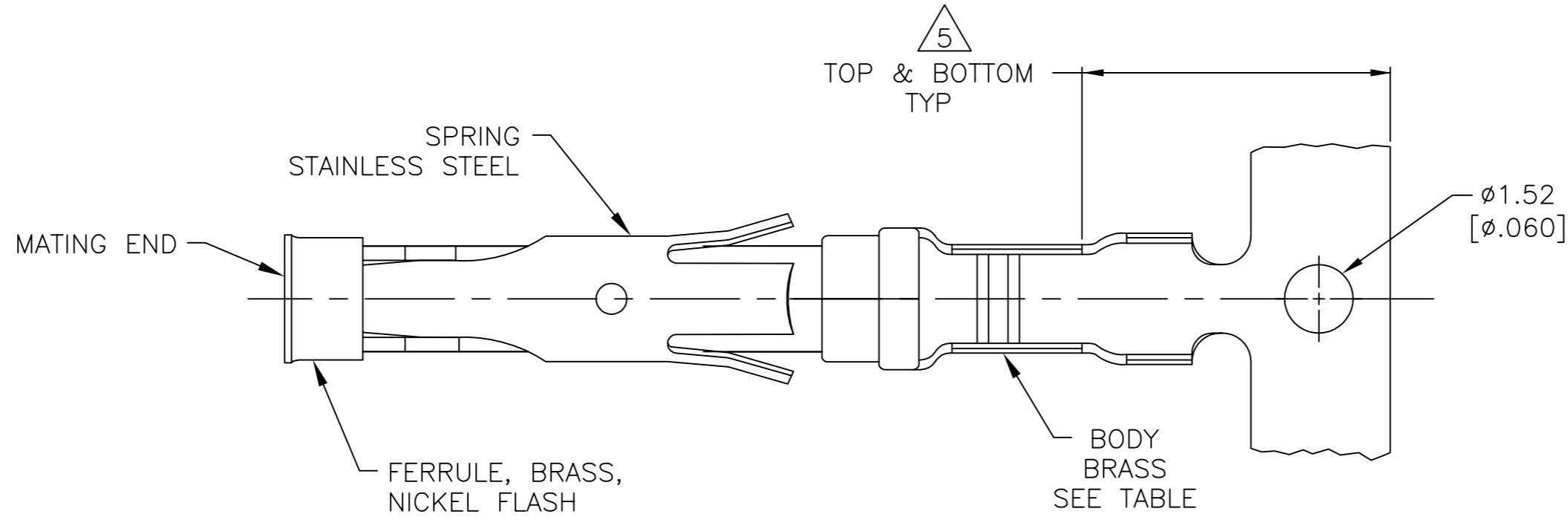
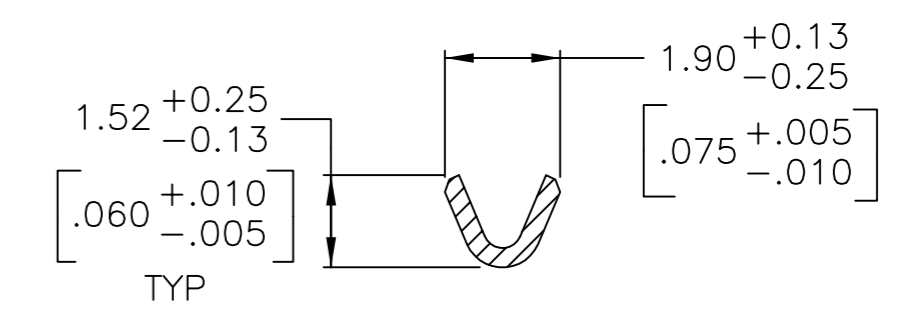
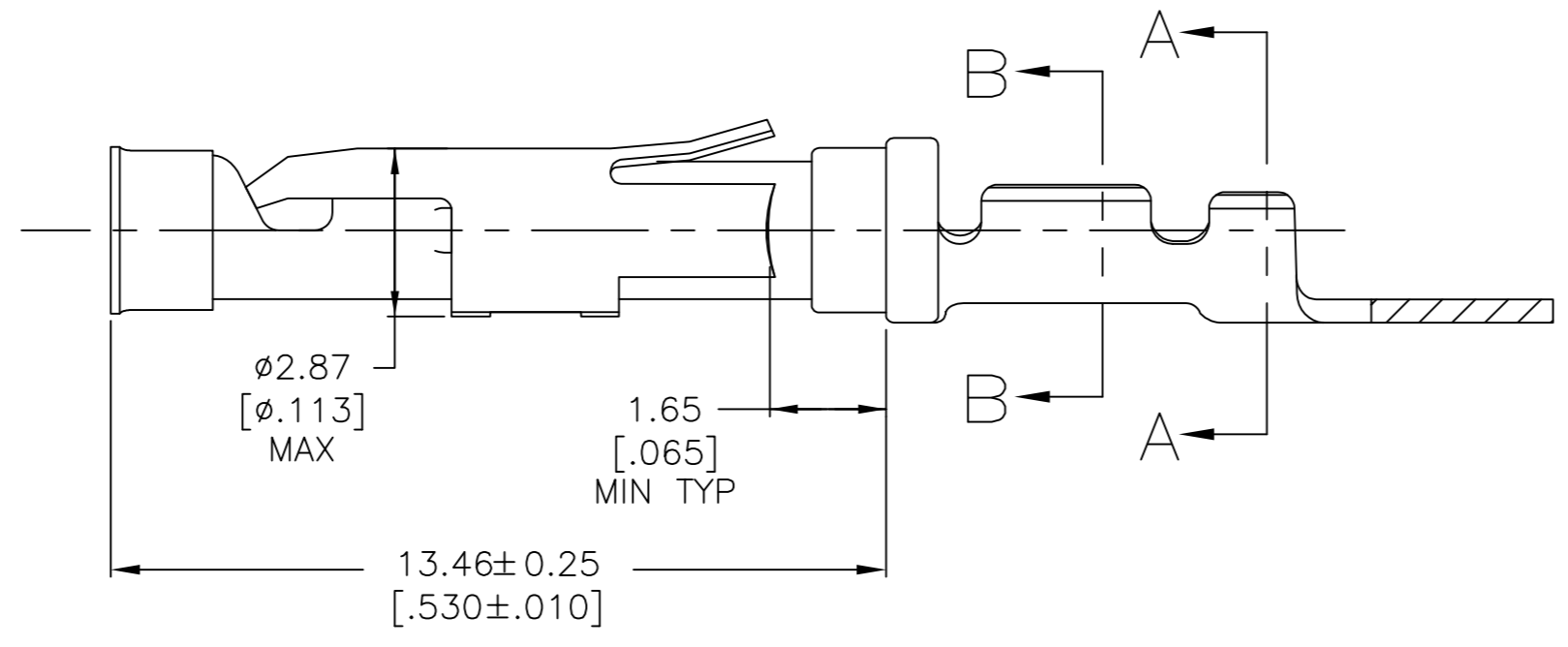
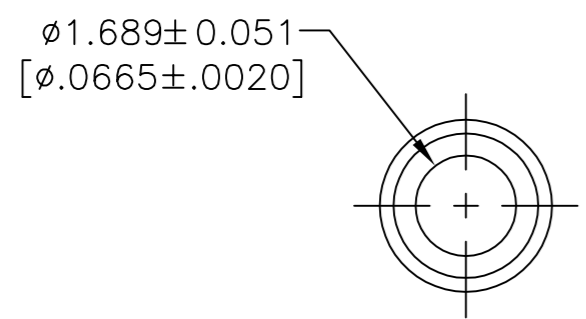

SECTION B-B

- 1 0.76μm [.000030] MIN GOLD PER MIL-G-45204 ON MATING END FOR A LENGTH OF 5.08 [.200] MIN WITH 1.27μm [.000050] MIN MATTE TIN PLATE IN WIRE CRIMP AREA, BOTH OVER 0.76μm [.000030] MIN NICKEL PER QQ-N-290.
- 2 1.27μm [.000050] MIN TIN-LEAD PER MIL-T-10727 OVER 0.76μm [.000030] MIN NICKEL PER QQ-N-290.
- 3 0.76μm [.000030] MIN GOLD PER MIL-G-45204 ON MATING END FOR A LENGTH OF 5.08 [.200] MIN WITH A UNIFORM GRADIENT TO 0.25μm [.000010] MIN GOLD PER MIL-G-45204 ON THE REMAINDER OVER 0.76μm [.000030] MIN NICKEL PER QQ-N-290.
- 4 0.38μm [.000015] MIN GOLD PER MIL-G-45204 ON MATING END FOR A LENGTH OF 5.08 [.200] MIN WITH 1.27μm [.000050] MIN MATTE TIN PLATE IN WIRE CRIMP AREA, BOTH OVER 0.76μm [.000030] MIN NICKEL PER QQ-N-290.
- 5 GOLD PLATING NEED NOT APPEAR IN THIS AREA.
- 6 REVERSE REELED FOR MINI-APPLICATOR.
- 7 WIRE RANGE 26-24 AWG. INSULATION RANGE 0.89 [.035]-1.40 [.055].
- 8 0.38μm [.000015] MIN GOLD PER MIL-G-45204 ON MATING END FOR A LENGTH OF 5.08 [.200] MIN, 1.27μm [.000050] MIN TIN-LEAD PER MIL-T-10727 FOR A LENGTH OF 5.69 [.224] MIN ON OPPOSITE END, BOTH OVER 1.27μm [.000050] MIN NICKEL PER QQ-N-290 ON ENTIRE CONTACT.
- 9 1.27μm [.000050] MIN TIN PER MIL-T-10727 OVER 0.76μm [.000030] MIN NICKEL PER QQ-N-290.
- 10 0.38μm [.000015] MIN GOLD PER MIL-G-45204 ON MATING END FOR A LENGTH OF 5.08 [.200] MIN, 1.27μm [.000050] TIN PER MIL-T-10727 FOR A LENGTH OF 5.69 [.224] MIN ON OPPOSITE END, BOTH OVER 1.27μm [.000050] MIN NICKEL PER QQ-N-290 ON ENTIRE CONTACT.

	STANDARD	9	1-66109-7	1-66108-7
OBSOLETE	6	10	-	1-66108-6
	6	9	1-66109-7	1-66108-5
OBSOLETE	6	8	1-66109-3	1-66108-4
	6	1	66109-4	66108-8
	6	4	66109-3	66108-7
	6	2	66109-2	66108-6
	6	3	66109-1	66108-5
	STANDARD	1	66109-4	66108-4
	STANDARD	4	66109-3	66108-3
	STANDARD	2	66109-2	66108-2
	STANDARD	3	66109-1	66108-1
	REELING	BODY FINISH	LOOSE PIECE REF	PART NO

THIS DRAWING IS A CONTROLLED DOCUMENT.		DWN R.SHIREY 08/06/91		
DIMENSIONS: mm [INCHES]		CHK R.STONE 9-19-91		
TOLERANCES UNLESS OTHERWISE SPECIFIED:		APVD J.WESTMAN 9-20-81	NAME SOCKET ASSEMBLY, .062, TYPE III+	
0 PLC ± -		PRODUCT SPEC -	SIZE A2	CAGE CODE 00779
1 PLC ± -		APPLICATION SPEC -	DRAWING NO C=66108	RESTRICTED TO -
2 PLC ± 0.13 [.005]		WEIGHT -	SCALE 8:1	SHEET 1 of 1
3 PLC ± -		CUSTOMER DRAWING	REV AJ	
4 PLC ± -				
ANGLES ± -				
FINISH SEE CALLOUTS				