

THIS DRAWING IS UNPUBLISHED. RELEASED FOR PUBLICATION  
 © COPYRIGHT - By - ALL RIGHTS RESERVED.

LOC		DIST		REVISIONS			
P	LTR	DESCRIPTION		DATE	DWN	APVD	
CM	00	G		REVISED PER ECR-13-008204	10DEC2013	KH	TM

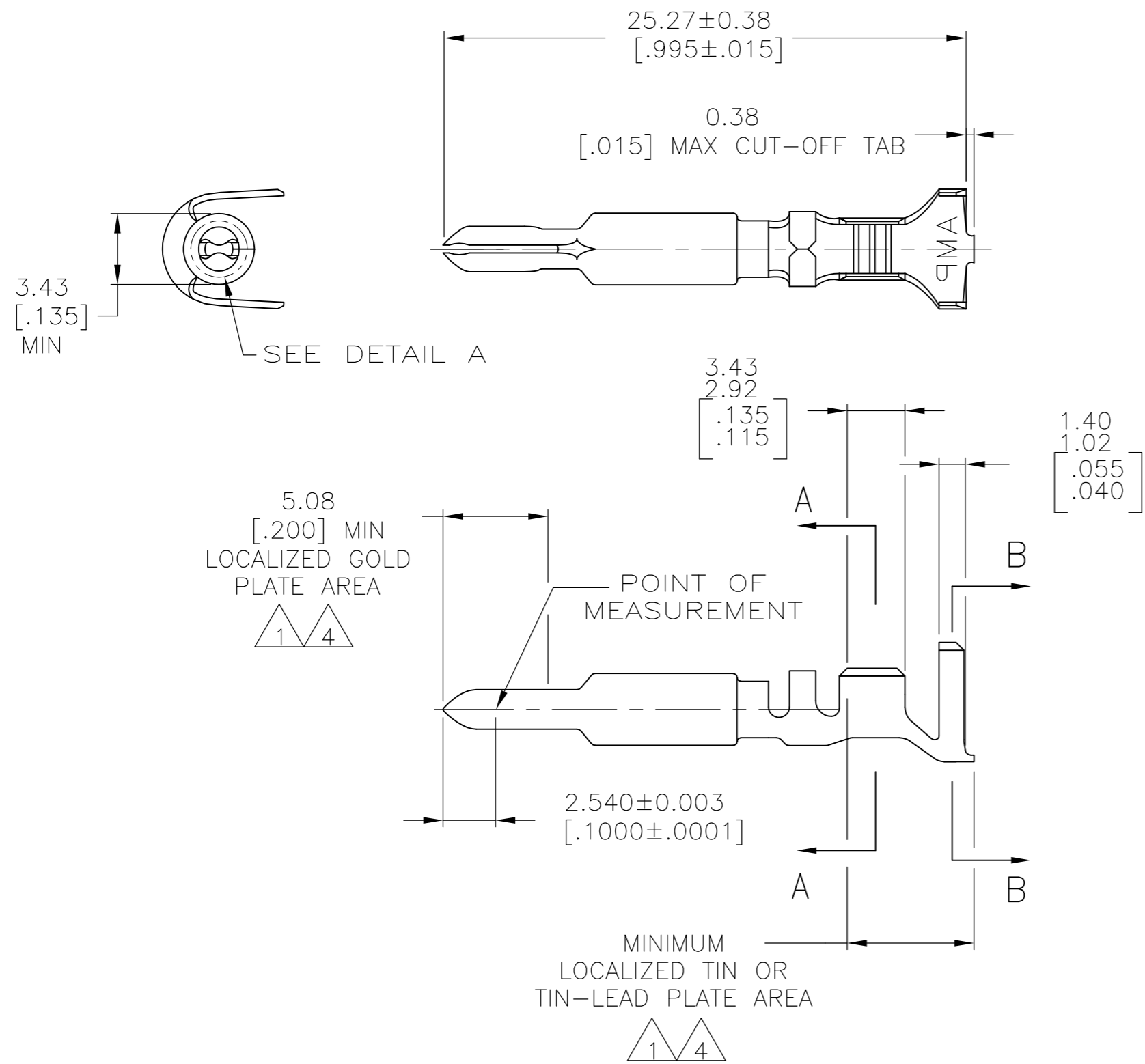

- 1 0.00076[.000030] MIN GOLD AT POINT OF MEASUREMENT IN THE LOCALIZED GOLD PLATE AREA, 0.00127[.000050] MIN TIN-LEAD IN TIN-LEAD PLATE AREA, 0.00127[.000050] MIN NICKEL UNDERPLATE ON ENTIRE CONTACT.
- 2 WIRE RANGE: 0.5-2mm<sup>2</sup> [20-14 AWG]. INSULATION RANGE: 3.30-5.08 [.130-.200] DIA.
- 3 DIMENSIONS IN BRACKETS ARE IN INCHES.
- 4 0.00076[.000030] MIN GOLD AT POINT OF MEASUREMENT IN THE LOCALIZED GOLD PLATE AREA, 0.00127[.000050] MIN TIN IN TIN PLATE AREA, 0.00127[.000050] MIN NICKEL UNDERPLATE ON ENTIRE CONTACT.
- 5 SUPERSEDED BY 1-770248-0

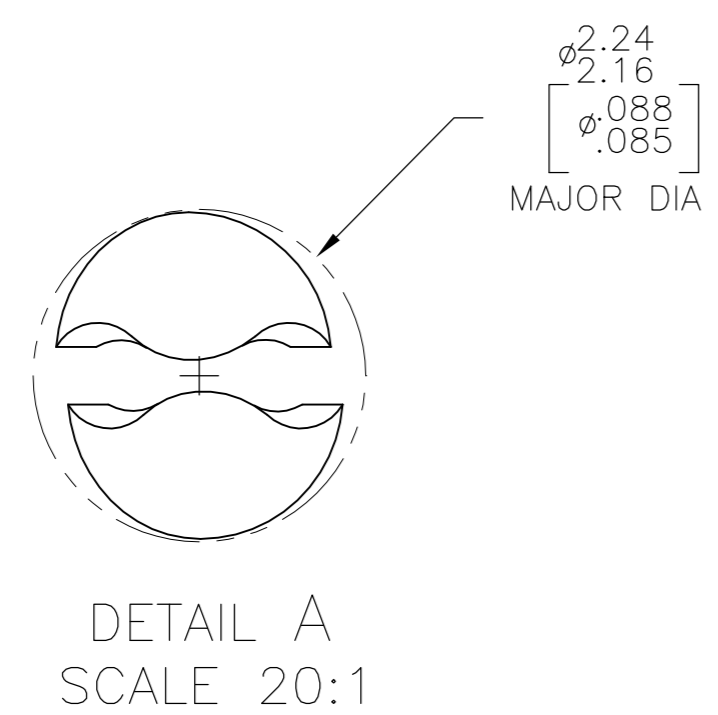
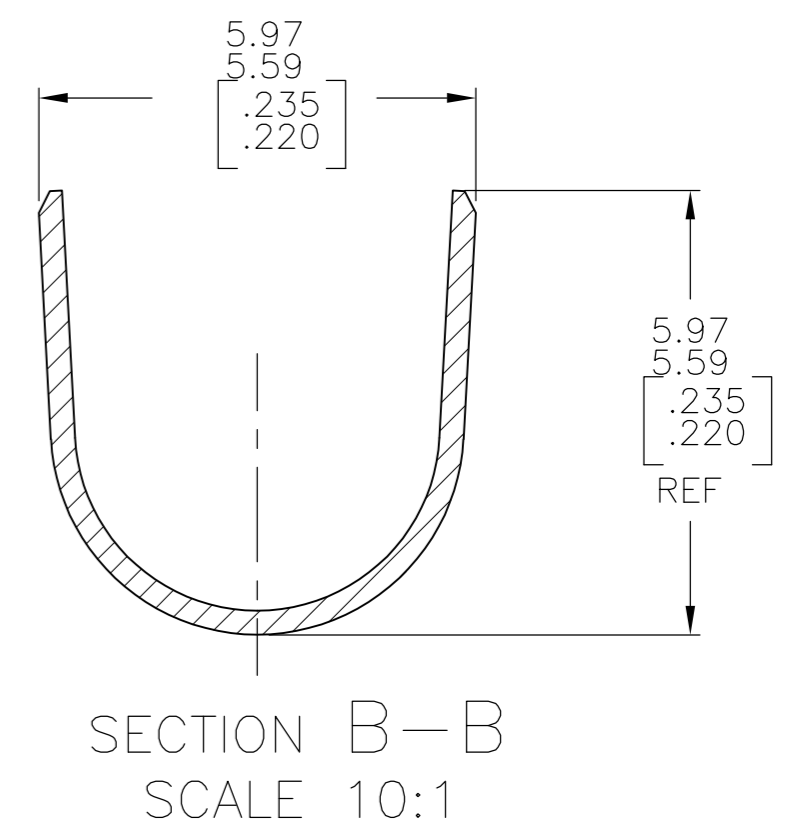
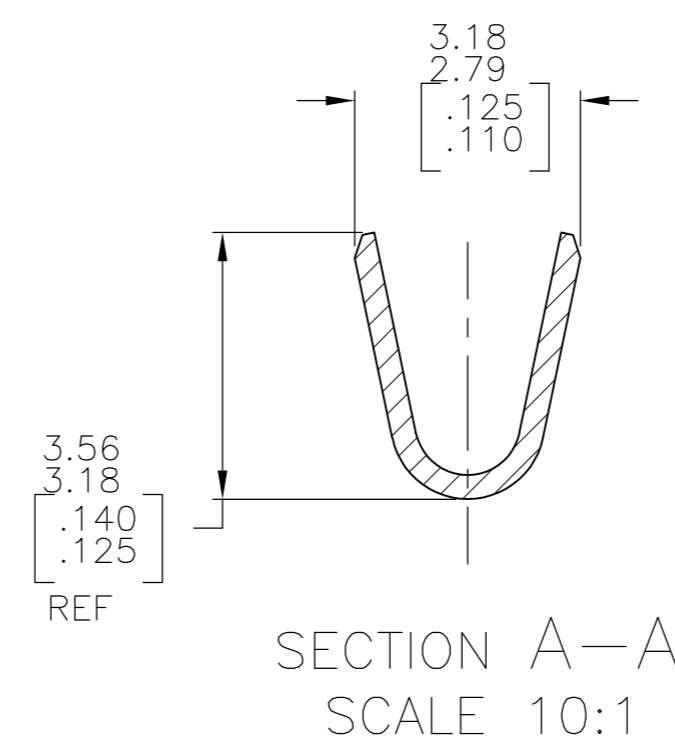

FINISH	MATERIAL	PART NUMBER
GOLD 4	0.30 [.012] BRASS	1-770248-0
GOLD 4	0.30 [.012] BRASS	-770248-2-
PRE-TIN	0.30 [.012] BRASS	770248-1

THIS DRAWING IS A CONTROLLED DOCUMENT.		DWN S. CARPENTER 21MAY03	<b>TE</b> TE Connectivity	
DIMENSIONS: mm [INCHES]		CHK C.JONES 21MAY03		
TOLERANCES UNLESS OTHERWISE SPECIFIED:		APVD C.JONES 21MAY03	NAME	
0 PLC ± -	1 PLC ± -	PRODUCT SPEC	PIN, LOOSE PIECE, UNIVERSAL MATE-N-LOK(TM) II	
2 PLC ± -	3 PLC ± -	APPLICATION SPEC	SIZE A2	CAGE CODE 00779
4 PLC ± -	ANGLES ± -	WEIGHT -	DRAWING NO C=770248	RESTRICTED TO -
MATERIAL SEE TABLE	FINISH SEE TABLE	CUSTOMER DRAWING	SCALE 4:1	SHEET 1 of 1
			REV G	