

THIS DOCUMENT AND THE DATA DISCLOSED HEREIN OR HEREWITH IS NOT TO BE REPRODUCED, USED, OR DISCLOSED IN WHOLE OR IN PART TO ANYONE WITHOUT PERMISSION OF VICOR CORP.

REV.	DESCRIPTION	DATE	APPROVED
1	RELEASED PER E050355	11/17/05	EF

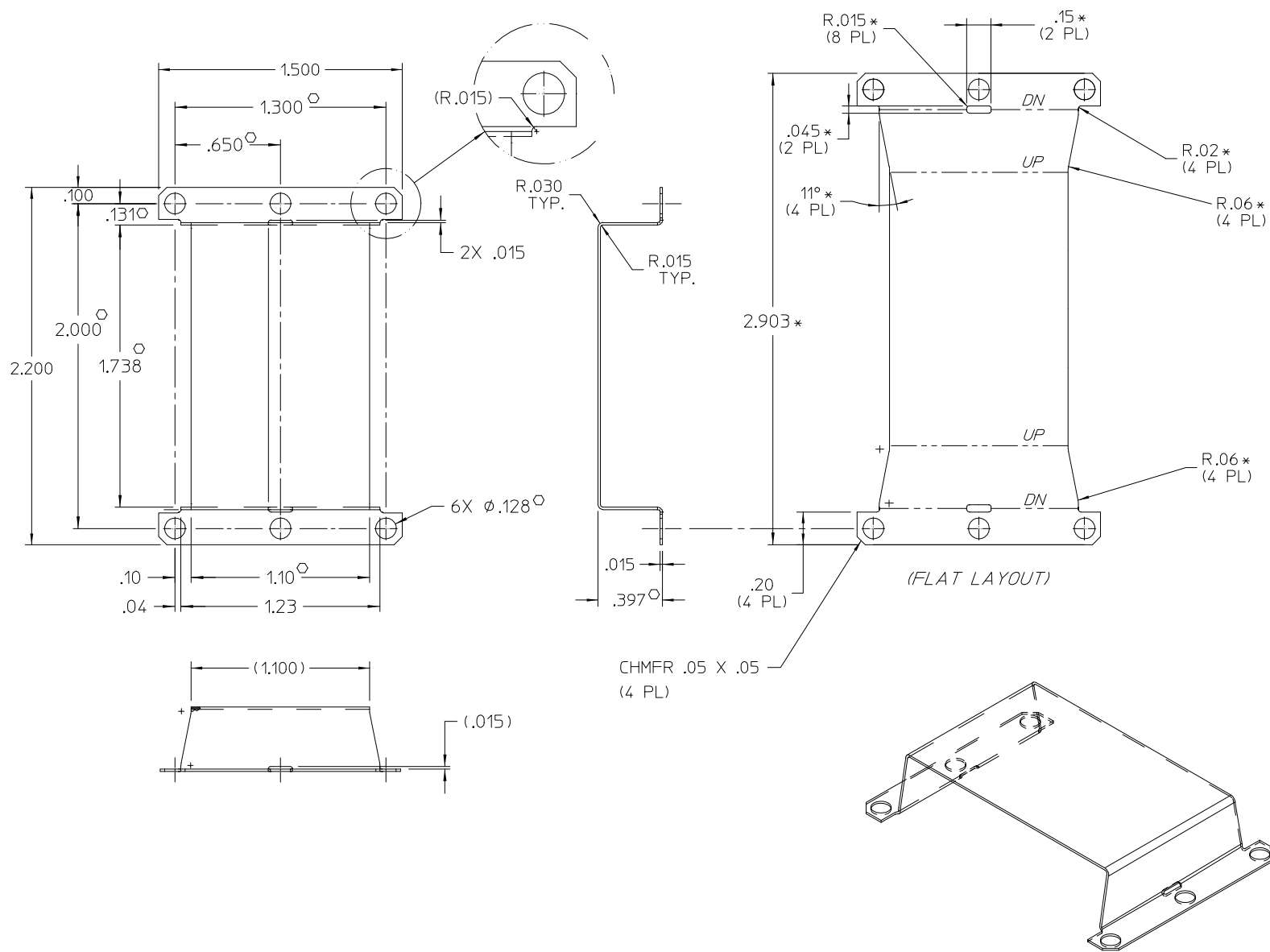

- NOTES:
1. MATERIAL: ALUMINUM- (.015) THK, 5052
  2. REMOVE BURRS & SHARP EDGES
  3. "\*" DIMENSIONS ARE NOT FOR VICOR INSPECTION.
  4.  $\diamond$  DENOTES CRITICAL CHARACTERISTICS FOR LOT INSPECTION.
  5. CLEAR FINISH, RoHS COMPLIANT, CHROMIUM FREE PER CST-0001, LATEST REVISION

DRAWN BY <i>P.E.IENI</i>	DATE 07/05/05			
<small>UNLESS OTHERWISE SPECIFIED DIMENSIONS ARE IN INCHES- TOLERANCES ARE:</small> <small>FRACTIONS DECIMALS ANGLES</small> <small>+1/64 .XX+ .01 *1°</small> <small>.XXX+.005</small>				
THIRD ANGLE PROJECTION 	SIZE C	FSCM NO. 67131	DWG NO. 30198	REV 1
DO NOT SCALE DRAWING	SCALE 2:1	SHEET 1 OF 1		