



## Dual-Slot PCMCIA Analog Power Controller

### General Description

The MAX780A provides the power switching and status signals necessary to control two Personal Computer Memory Card International Association (PCMCIA) Release 2.0 card slots. The MAX780A, used in conjunction with a PC Card Interface Digital Controller, forms a complete, minimum component count PCMCIA interface for palmtop and notebook computers.

The MAX780A incorporates two 0V/+5V/+12V/high-impedance power outputs for flash V<sub>PP</sub> programming, level shifters for power MOSFET control of two separate +3.3V/+5V supplies, and two V<sub>PP</sub> power-ready status signals. The MAX780A may be directly connected to the control outputs from a PCMCIA digital controller, or may be configured to use internal edge-triggered registers for connection to the CPU data bus.

The MAX780B has all the features of the MAX780A but omits the reference and V<sub>PP</sub> valid indicators. The MAX780C has all the features of the MAX780A but omits the registers for the digital inputs. The MAX780D omits the reference, the V<sub>PP</sub> valid indicators, and the digital input registers.

Part Number	Reference & V <sub>PP</sub> Status Indicators	Registers for Direct Connection to CPU Data Bus	Dual V <sub>PP</sub> Switches & Level Shifters for V <sub>CC</sub> Switching
MAX780A	✓	✓	✓
MAX780B		✓	✓
MAX780C	✓		✓
MAX780D			✓

### Applications

Notebook and Palmtop Computers  
 Personal Organizers  
 Digital Cameras  
 Handterminals  
 Bar-Code Readers

### Features

- ♦ SSOP Circuit Fits in 0.09in<sup>2</sup>
- ♦ Smallest Complete Analog Controller for Two PCMCIA (Release 2.0/JEIDA 4.1) PC Card Sockets
- ♦ Dual V<sub>CC</sub> Controls and V<sub>PP</sub> Outputs
- ♦ Logic-Compatible with Industry-Standard PCMCIA Digital Controllers:
  - Intel 82365SL\_DF
  - Fujitsu MB86301
  - Chips and Technology F8680
  - Cirrus Logic CL-PD6720
- ♦ 0V/+5V/+12V/High-Impedance V<sub>PP</sub> Outputs
- ♦ Internal 1.6Ω V<sub>PP</sub> Power Switches
- ♦ Dual Voltage 3.3V/5V V<sub>CC</sub> Operation
- ♦ V<sub>PP</sub> Power-Ready Status Signals
- ♦ 130μA Quiescent Supply Current (3.5μA in Shutdown)
- ♦ Break-Before-Make Switching

### Ordering Information

PART	TEMP. RANGE	PIN-PACKAGE
MAX780ACNG	0°C to +70°C	24 Narrow Plastic DIP
MAX780ACAG	0°C to +70°C	24 SSOP
MAX780AC/D	0°C to +70°C	Dice*
MAX780AENG	-40°C to +85°C	24 Narrow Plastic DIP
MAX780AEAG	-40°C to +85°C	24 SSOP

Ordering Information continued on last page.

\* Contact factory for dice specifications.

### Typical Operating Circuit

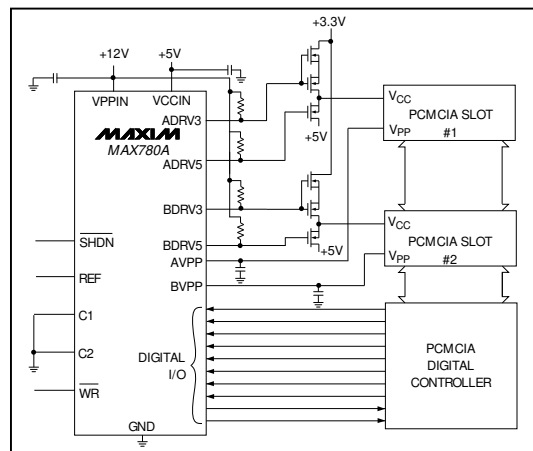

# Dual-Slot PCMCIA Analog Power Controller

## ABSOLUTE MAXIMUM RATINGS

VCCIN to GND	+7V, -0.3V
VPPIN to GND	+13.2V, -0.3V
ADRV5, ADRV3, BDRV5, BDRV3 to GND	(VPPIN + 0.3V), -0.3V
AVPP, BVPP to GND	(VPPIN + 0.3V), -0.3V
All Other Pins to GND	(VCCIN + 0.3V), -0.3V
Continuous Power Dissipation (T <sub>A</sub> = +70°C)	
20-Pin Plastic DIP (derate 11.11mW/°C above +70°C)	889mW
20-Pin SSOP (derate 8.00mW/°C above +70°C)	640mW
24-Pin Narrow Plastic DIP (derate 13.33 mW/°C above +70°C)	1067mW
24-Pin SSOP (derate 8.00mW/°C above +70°C)	640mW

### Operating Temperature Ranges:

MAX780_C	0°C to +70°C
MAX780_E	-40°C to +85°C
Storage Temperature Range	-65°C to +160°C
Lead Temperature (soldering, 10sec)	+300°C

Stresses beyond those listed under "Absolute Maximum Ratings" may cause permanent damage to the device. These are stress ratings only, and functional operation of the device at these or any other conditions beyond those indicated in the operational sections of the specifications is not implied. Exposure to absolute maximum rating conditions for extended periods may affect device reliability.

## ELECTRICAL CHARACTERISTICS

(VCCIN = +5V, VPPIN = +12V, T<sub>A</sub> = T<sub>MIN</sub> to T<sub>MAX</sub>, unless otherwise noted.)

PARAMETER	CONDITIONS	MIN	TYP	MAX	UNITS	
<b>POWER REQUIREMENTS</b>						
VCCIN Input Voltage Range		2.85		5.5	V	
VPPIN Input Voltage Range		0		12.6	V	
VCCIN Supply Current	5V mode		130	300	μA	
	12V or 0V mode		60			
VPPIN Supply Current	VPPIN = 12.6V	12V mode	185	450	μA	
		5V mode	10			
VCCIN Standby Current	SHDN = 0V, all logic inputs at GND or VCCIN		3.5	10	μA	
VPPIN Standby Current	SHDN = 0V, VPPIN = 4.75V		0.1	1	μA	
<b>DC CHARACTERISTICS</b>						
AVPP, BVPP Switch Resistance	VPPIN = 11.4V, 0mA < I <sub>LOAD</sub> < 60mA, 12V mode		1.6	2.45	Ω	
	VCCIN = 4.5V, 0mA < I <sub>LOAD</sub> < 1mA, 5V mode		30	50		
	VPPIN = 11.4V, 0mA < I <sub>LOAD</sub> < 1mA, 0V mode		140	300		
ADRV3, ADRV5, BDRV3, BDRV5 Leakage Current	High-impedance mode		1	50	nA	
ADRV3, ADRV5, BDRV3, BDRV5 Output Voltage Low	I <sub>LOAD</sub> = 1mA		0.1	0.4	V	
<b>VOLTAGE REFERENCE (MAX780A and MAX780C only)</b>						
REF Voltage	I <sub>LOAD</sub> = 0μA	MAX780_C	1.22	1.25	1.28	V
		MAX780_E	1.21	1.25	1.29	
REF Temperature Coefficient			20		ppm/°C	
REF Line Regulation	VCCIN = 2.85V to 5.5V		0.5		mV/V	
REF Load Regulation	I <sub>LOAD</sub> = 0μA to 100μA		2		μV/μA	
AGPI, BGPI Power-Ready Threshold	MAX780_C	10.72	11.05	11.40	V	
	MAX780_E	10.68	11.05	11.40		
AGPI, BGPI Power-Ready Hysteresis	12V mode	VPPIN ↓		130	mV	
		VPPIN ↑		0		

## Dual-Slot PCMCIA Analog Power Controller

### ELECTRICAL CHARACTERISTICS (continued)

(VCCIN = +5V, VPPIN = +12V, T<sub>A</sub> = T<sub>MIN</sub> to T<sub>MAX</sub>, unless otherwise noted.)

PARAMETER	CONDITIONS	MIN	TYP	MAX	UNITS
<b>LOGIC SECTION</b>					
Logic Input Leakage Current				1	μA
Logic Input High		2.4			V
Logic Input Low				0.8	V
AGPI, BGPI Logic Output High	I <sub>LOAD</sub> = 1mA	VCCIN -0.4	VCCIN -0.2		V
AGPI, BGPI Logic Output Low	I <sub>LOAD</sub> = 1mA		0.06	0.4	V

### TIMING CHARACTERISTICS - MAX780A and MAX780B only

(VCCIN = +3.3V or +5.0V, VPPIN = +12.0V, see Figure 4, T<sub>A</sub> = T<sub>MIN</sub> to T<sub>MAX</sub>, unless otherwise noted.)

PARAMETER	SYMBOL	CONDITIONS	MIN	TYP	MAX	UNITS
WR Pulse Width	t <sub>LA</sub>		125			ns
_VPP_, _VCC_ Setup Time	t <sub>AS</sub>		100			ns
_VPP_, _VCC_ Hold Time	t <sub>AH</sub>	(Note 1)	0			ns
_VCC_ to _DRV_ Propagation Delay				50		ns

**Note 1:** Guaranteed by design, not production tested.

### Typical Operating Characteristics

**AVPP SWITCHING**

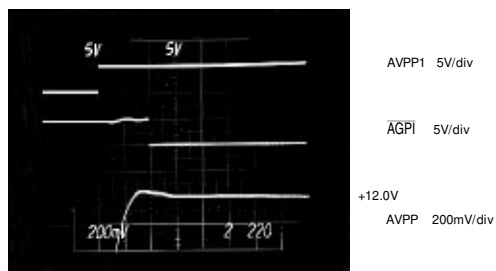

5μs/div  
C1 = C2 = 0V, AVPP0 = +5V, CIN = 10μF, CA = 0.1μF

**AVCC SWITCHING**

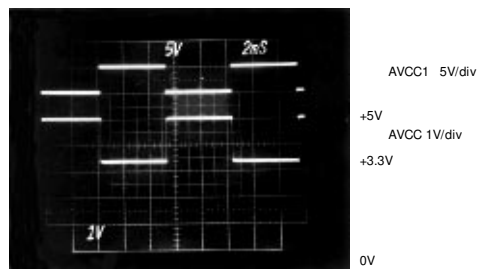

2ms/div  
C1 = +5V, C2 = 0V, AVCC0 = +5V, M1 = M2 = 3055EL,  
R<sub>LOAD</sub> = 130Ω, C<sub>C</sub> = 1μF

# Dual-Slot PCMCIA Analog Power Controller

## Typical Operating Characteristics (continued)

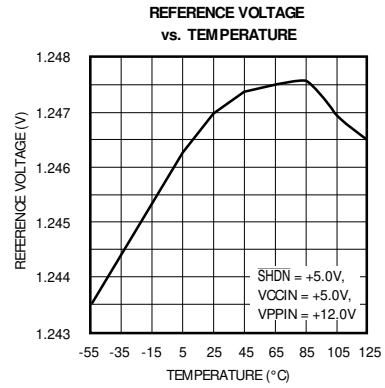
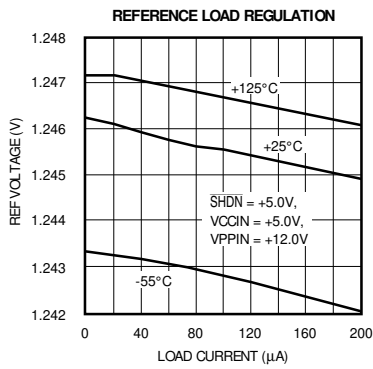
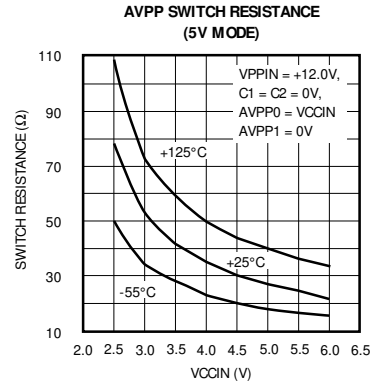
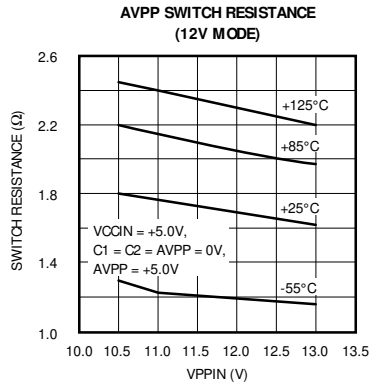

# Dual-Slot PCMCIA Analog Power Controller

## Pin Description

**MAX780**

PIN		NAME	FUNCTION
MAX780A/B/C	MAX780D		
1		C2	Pin-strap input that selects edge-triggered register or direct digital inputs. Tying C2 to VCCIN makes the logic inputs edge triggered; inputs to pins 4-11 are clocked in on the rising edge of WR. Tying C2 to GND allows control signals to be directly applied to the logic inputs on pins 4-11. Connect to GND for MAX780C.
2	1	C1	Pin-strap input that selects one of two logic decode modes for the digital inputs. See Tables 1-3.
3		WR	Write pulse input. When C2 is tied to VCCIN, a rising edge on $\overline{WR}$ clocks in the V <sub>CC</sub> and V <sub>PP</sub> enables. When C2 is tied to GND, inputs to WR have no effect. Connect to GND for MAX780C.
4, 5	2, 3	AVPP1, AVPP0	Logic inputs that control the voltage on AVPP.
6, 7	4, 5	BVPP1, BVPP0	Logic inputs that control the voltage on BVPP.
8, 9	6, 7	AVCC1, AVCC0	Logic inputs that control the state of the MOSFET gate drivers ADRV3 and ADRV5.
10, 11	8, 9	BVCC1, BVCC0	Logic inputs that control the state of the MOSFET gate drivers BDRV3 and BDRV5.
12, 13	10, 11	BDRV5, BDRV3	Open-drain gate driver outputs that control the MOSFETs that switch the V <sub>CC</sub> pin of slot B to 0V, 3.0V/3.3V, or 5V.
14, 15	12, 13	ADRV5, ADRV3	Open-drain gate driver outputs that control the MOSFETs that switch the V <sub>CC</sub> pin of slot A to 0V, 3.0V/3.3V, or 5V.
16		$\overline{BGPI}$	Logic-level power-ready output that stays low as long as BVPP is greater than 11.05V (MAX780A and MAX780C only). Make no connection to this pin for MAX780B.
17		$\overline{AGPI}$	Logic-level power-ready output that stays low as long as AVPP is greater than 11.05V (MAX780A and MAX780C only). Make no connection to this pin for MAX780B.
18	14	SHDN	Logic input that shuts the MAX780 down to a low supply-current state when brought low. Asserting SHDN forces ADRV3, BDRV3, ADRV5, BDRV5, REF, $\overline{AGPI}$ , and $\overline{BGPI}$ low. All V <sub>PP</sub> inputs and outputs are functional for either state of SHDN. Program AVPP and BVPP to 0V for lowest power consumption.
	15	N.C.	No connect. Not internally connected.
19		REF	1.25V reference voltage output (MAX780A and MAX780C only). Make no connection to this pin for MAX780B.)
20	16	BVPP	Switched output that provides 0V, 5V, or 12V to the V <sub>PP</sub> pins of slot B.
21	17	AVPP	Switched output that provides 0V, 5V, or 12V to the V <sub>PP</sub> pins of slot A.
22	18	VCCIN	+5V power input
23	19	VPPIN	+12V power input. VPPIN can have 0V or 5V applied as long as VCCIN = 5V.
24	20	GND	Ground

## Dual-Slot PCMCIA Analog Power Controller

Table 1. AVPP Control Logic

C1	AVPP1	AVPP0	AVPP
0	0	0	0V
0	0	1	VCCIN
0	1	0	VPPIN
0	1	1	High-Z
1	0	0	0V
1	0	1	0V
1	1	0	VCCIN
1	1	1	VPPIN

Table 2. BVPP Control Logic

C1	BVPP1	BVPP0	BVPP
0	0	0	0V
0	0	1	VCCIN
0	1	0	VPPIN
0	1	1	High-Z
1	0	0	0V
1	0	1	0V
1	1	0	VCCIN
1	1	1	VPPIN

Table 3. ADRV3 and ADRV5 Control Logic

C1	AVCC1	AVCC0	ADRV3	ADRV5
0	0	0	0V	0V
0	0	1	Hi-Z	0V
0	1	0	0V	Hi-Z
0	1	1	0V	0V
1	0	0	0V	0V
1	0	1	0V	0V
1	1	0	0V	Hi-Z
1	1	1	Hi-Z	0V

Table 4. BDRV3 and BDRV5 Control Logic

C1	BVCC1	BVCC0	BDRV3	BDRV5
0	0	0	0V	0V
0	0	1	Hi-Z	0V
0	1	0	0V	Hi-Z
0	1	1	0V	0V
1	0	0	0V	0V
1	0	1	0V	0V
1	1	0	0V	Hi-Z
1	1	1	Hi-Z	0V

### Detailed Description

#### V<sub>PP</sub> Switching

All four versions (A, B, C, and D) of the MAX780 allow simple switching of PCMCIA card V<sub>PP</sub> to 0V, 5V, and 12V. On-chip power MOSFETs connect AVPP and BVPP to either GND, VCCIN, or VPPIN. The AVPP0 and AVPP1 control logic inputs determine the state of AVPP. Likewise, BVPP0 and BVPP1 control BVPP.

To prevent V<sub>PP</sub> overshoot due to parasitic inductance in the +12V supply, the VPPIN bypass capacitor (C<sub>IN</sub>) should be 10 times greater than the capacitance from AVPP (C<sub>A</sub>) or BVPP (C<sub>B</sub>) to GND. Hence, when C<sub>A</sub> and C<sub>B</sub> are 0.1μF, C<sub>IN</sub> should be 1.0μF.

The AGPI and BGPI status outputs signal when the V<sub>PP</sub> lines are valid. AGPI goes low when AVPP exceeds 11.05V; BGPI goes low when BVPP exceeds 11.05V. The status outputs and the reference are only active when SHDN is high.

Pulling SHDN low puts the MAX780 into a low supply-current mode and disables the reference and the AGPI and BGPI status outputs. The V<sub>CC</sub> level shifters ADRV5, ADRV3, BDRV5, BDRV3 are all forced low when SHDN is low. V<sub>PP</sub> switching is not affected by the state of SHDN. Program AVPP and BVPP to 0V for lowest power consumption when SHDN is low. Wait at least 200μs after bringing the MAX780 out of shutdown before checking AGPI or BGPI since the reference needs time to stabilize.

#### V<sub>CC</sub> Switching

The MAX780 contains level shifters that simplify driving external power MOSFETs to switch PCMCIA card V<sub>CC</sub> to 3.3V and 5V. While a PCMCIA card is being inserted into the socket, the V<sub>CC</sub> pins on the card edge connector should be powered down to 0V so that "hot insertion" does not damage the PCMCIA card. The simplest way to accomplish this is to pull out a mechanical switch before the PCMCIA card is inserted. The mechanical switch can be pushed in only when the card has been fitted snugly into its socket. The MAX780 *Detailed Operating Circuit* shows this method.

In the *Detailed Operating Circuit*, (with the mechanical interlock switch closed) the PCMCIA card V<sub>CC</sub> cannot be pulled more than a diode drop below 3.3V. The N-channel power MOSFET that connects V<sub>CC</sub> to 3.3V has its drain tied to V<sub>CC</sub> and its source tied to 3.3V, so that its body diode prevents the card's V<sub>CC</sub> from falling to 0V. If it were rotated so that the source connected to V<sub>CC</sub>, then applying 5V to V<sub>CC</sub> would short the 5V supply to the 3.3V supply via the MOSFET's body diode.

## Dual-Slot PCMCIA Analog Power Controller

If a mechanical interlock switch cannot be used, an extra MOSFET must be added, as shown in Figure 1. Placing two N-channel MOSFETs in series with their body diodes facing in opposite directions allows  $V_{CC}$  to be shut down to 0V without using a mechanical switch.

### Switching Speed

The drive to the external MOSFETs ensures that the 3.3V supply is never connected to the 5V supply. This is done by turning these transistors off quickly (using active pull-down circuitry), and on more slowly (using external pull-up resistors). The turn-on delay depends on the value of the pull-up resistors, and on the gate capacitance of the switching transistors. To save power, use high-value resistors of up to 10M $\Omega$ . However, note that high-value resistors will increase the time it takes to turn on the switched supplies

### Applications Information

The MAX780 can be used with PCMCIA controllers other than the Intel 82365SL DF. Figure 2 shows the logic connections to the Cirrus Logic CL-PD6720 PCMCIA Host Adapter.

The MAX780 does not need a PCMCIA controller to function. Tie C2 to VCCIN to allow direct  $V_{CC}$  and  $V_{PP}$  control from the system bus. Figure 3 shows the connection to the system bus. Figure 4 shows the timing requirements.

### Reading from a PCMCIA Port without Using the $V_{PP}$ Supply

In the *Typical Operating Circuit*,  $V_{CC}$  is switched to the PCMCIA ports using the 12V  $V_{PP}$  supply, which provides the gate drive needed to turn on the external N-channel MOSFETs. In some cases, the high-power  $V_{PP}$  supply is only available when information has to be written to the PCMCIA port, not when data is being read. The  $V_{PP}$  supply may have a quiescent current of several milliamps, so it consumes more power than is necessary simply to provide gate drive for some FETs.

In these circumstances, a separate gate-drive supply is needed to turn on the external FETs. Ideally it should have a low quiescent current and be capable of being turned off when read access to the PCMCIA port is not required. Doubling or tripling charge pumps can easily be built using a convenient clock signal from elsewhere in the system. Buffering the clock signal with a suitable gate provides on/off control, as shown in Figure 5.

When driven at 100kHz or more by a CMOS gate powered from 5V, the doubler circuit outputs 8.6V when loaded with 25k $\Omega$  (equivalent to four 100k $\Omega$  pull-up resistors). Under similar conditions, but when running from 3.3V, the tripler circuit produces 7.9V.

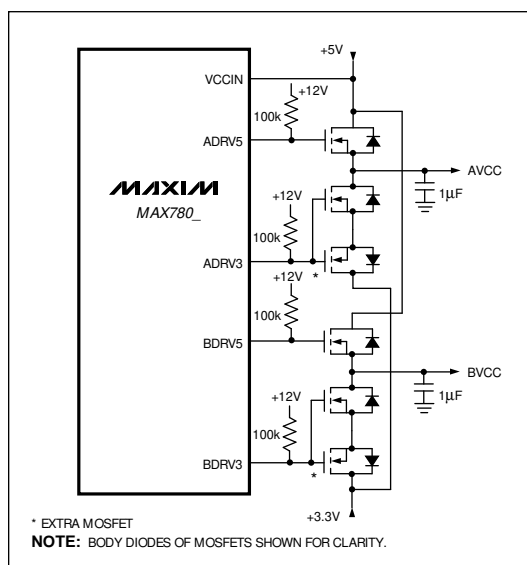

Figure 1. Using an Extra MOSFET to Replace the Mechanical Interlock

## Dual-Slot PCMCIA Analog Power Controller

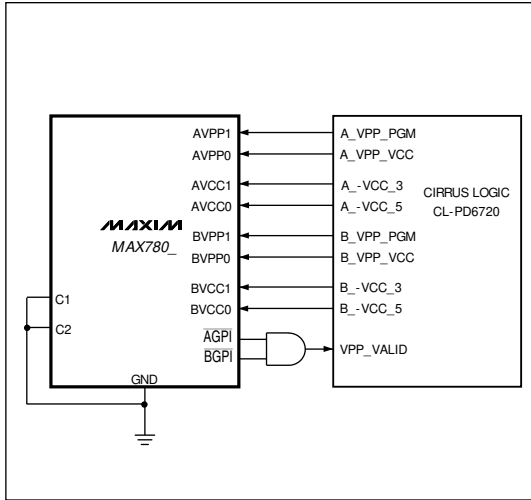

Figure 2. Logic Connections to CL-PD6720

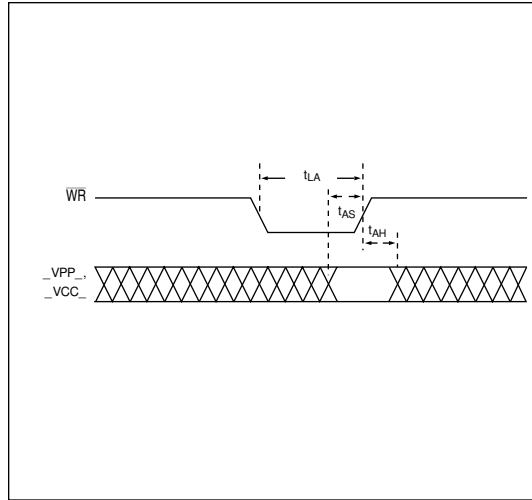

Figure 4. C2 = VCCIN Mode Timing

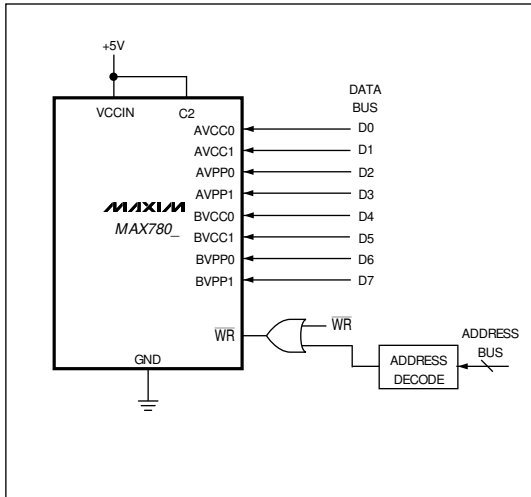

Figure 3. Direct Connection to System Bus

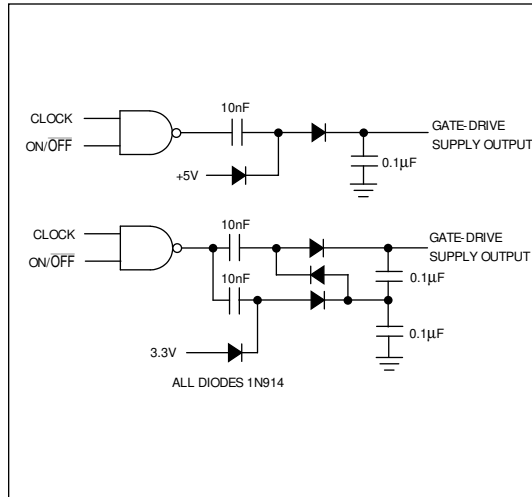

Figure 5. Alternative Gate-Drive Charge-Pump Supplies



# Dual-Slot PCMCIA Analog Power Controller

## Pin Configurations (continued)

**MAX780**

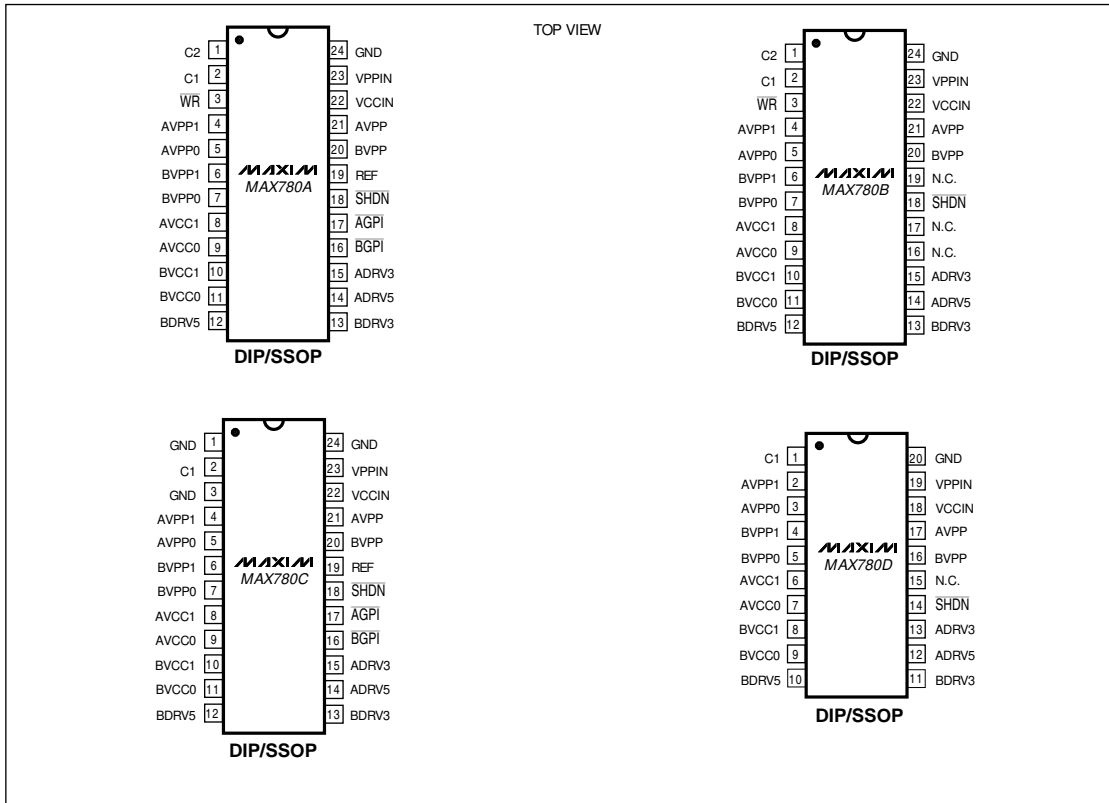

# Dual-Slot PCMCIA Analog Power Controller

## Detailed Operating Circuit

**MAX780**

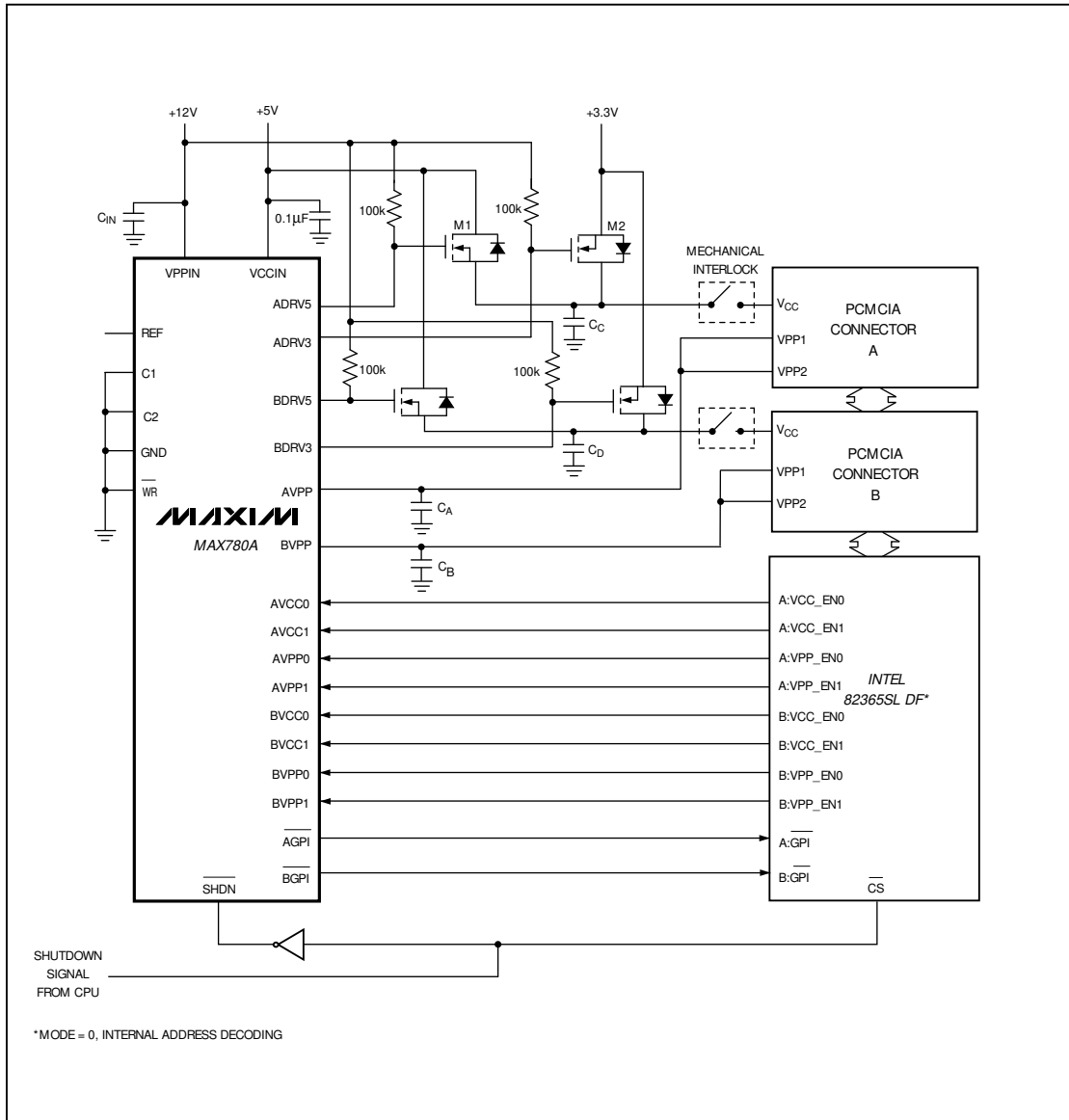

# Dual-Slot PCMCIA Analog Power Controller

## Ordering Information (continued)

PART	TEMP. RANGE	PIN-PACKAGE
MAX780BCNG	0°C to +70°C	24 Narrow Plastic DIP
MAX780BCAG	0°C to +70°C	24 SSOP
MAX780BC/D	0°C to +70°C	Dice*
MAX780BENG	-40°C to +85°C	24 Narrow Plastic DIP
MAX780BEAG	-40°C to +85°C	24 SSOP
MAX780CCNG	0°C to +70°C	24 Narrow Plastic DIP
MAX780CCAG	0°C to +70°C	24 SSOP
MAX780CC/D	0°C to +70°C	Dice*
MAX780CENG	-40°C to +85°C	24 Narrow Plastic DIP
MAX780CEAG	-40°C to +85°C	24 SSOP
MAX780DCPP	0°C to +70°C	20 Plastic DIP
MAX780DCAP	0°C to +70°C	20 SSOP
MAX780DC/D	0°C to +70°C	Dice*
MAX780DEPP	-40°C to +85°C	20 Plastic DIP
MAX780DEAP	-40°C to +85°C	20 SSOP

\* Contact factory for dice specifications.

## Chip Topography

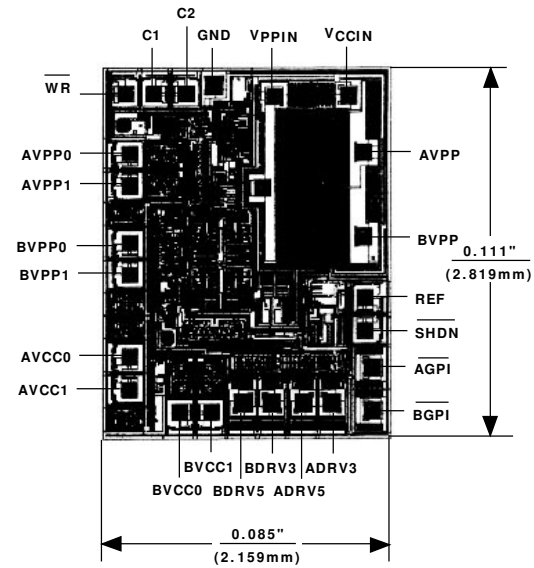

MAX780

## Package Information

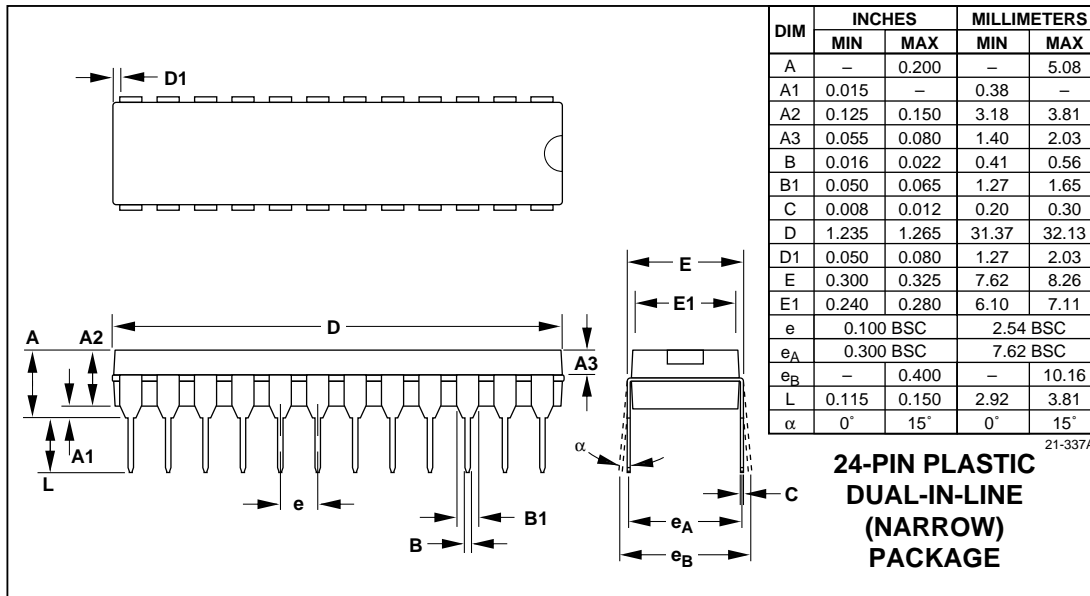

# Dual-Slot PCMCIA Analog Power Controller

## Package Information (continued)

DIM	INCHES		MILLIMETERS	
	MIN	MAX	MIN	MAX
A	0.068	0.078	1.73	1.99
A1	0.002	0.008	0.05	0.21
B	0.010	0.015	0.25	0.38
C	0.005	0.009	0.13	0.22
D	0.278	0.328	7.07	8.33
E	0.205	0.212	5.20	5.38
e	0.0256 BSC		0.65 BSC	
H	0.301	0.311	7.65	7.90
L	0.022	0.037	0.55	0.95
α	0°	8°	0°	8°

21-0002A

**24-PIN PLASTIC SHRINK SMALL-OUTLINE PACKAGE**

DIM	INCHES		MILLIMETERS	
	MIN	MAX	MIN	MAX
A	—	0.200	—	5.08
A1	0.015	—	0.38	—
A2	0.125	0.150	3.18	3.81
A3	0.055	0.080	1.40	2.03
B	0.016	0.022	0.41	0.56
B1	0.050	0.065	1.27	1.65
C	0.008	0.012	0.20	0.30
D	1.015	1.045	25.78	26.54
D1	0.040	0.070	1.02	1.78
E	0.300	0.325	7.62	8.26
E1	0.240	0.280	6.10	7.11
e	0.100 BSC		2.54 BSC	
e <sub>A</sub>	0.300 BSC		7.62 BSC	
e <sub>B</sub>	—	0.400	—	10.16
L	0.115	0.150	2.92	3.81
α	0°	15°	0°	15°

21-333A

**20-PIN PLASTIC DUAL-IN-LINE PACKAGE**

Maxim cannot assume responsibility for use of any circuitry other than circuitry entirely embodied in a Maxim product. No circuit patent licenses are implied. Maxim reserves the right to change the circuitry and specifications without notice at any time.

12 Maxim Integrated Products, 120 San Gabriel Drive, Sunnyvale, CA 94086 (408) 737-7600