

NOTES: UNLESS OTHERWISE SPECIFIED

1. THIS COMPONENT CONFORMS TO UL60950. UL FILE NO. IS: E216117.

	WARNING: THIS COMPONENT IS RECOGNIZED BY ONE OR MORE SAFETY AGENCIES SUCH AS UL, VDE, CSA AND/OR TUV. ALL ENGINEERING CHANGES MUST HAVE PRIOR APPROVAL BY THE DESIGN CENTER QUALITY DEPARTMENT FOR SAFETY AGENCY COMPLIANCE.	ECN APPROVAL:
		QA APPROVAL:
		DATE:

2. **NOTICE:** THIS IS A RoHS COMPLIANT COMPONENT/PRODUCT. ALL ENGINEERING CHANGES MUST HAVE PRIOR APPROVAL BY THE DESIGN CENTER.

3. PLASTIC HOUSING: THERMOPLASTIC MATERIAL WITH FLAMMABILITY RATING UL 94V-0 OR BETTER.
4. CONTACT BASE MATERIAL: PHOSPHOR BRONZE.
5. CONTACTS UNDERPLATE: 30-50 MICROINCHES DUCTILE NICKEL.
6. CONTACTS PLATING: 50 MICROINCHES GOLD PLATING.
7. SOLDER TAIL PLATING MATERIAL: 200-500 MICROINCHES 100% TIN, MATTE FINISH.
8. METAL SHIELD: NICKEL PLATING ON COPPER ALLOY.
9. JACK CAVITY CONFORMS TO FCC RULES AND REGULATIONS PART 68 SUBPART F.
10. PCB PLATING: HASL (TOP PCB)
ENIG (BOTTOM PCB)
11. SOLDERABILITY: CONFORMS TO ANSI/J-STD-002, IPC/EIA J-STD-003A.
12. OPERATING TEMPERATURE: 0°C TO +70°C
13. STORAGE TEMPERATURE: -20°C TO +125°C
14. JEDEC MOISTURE: LEVEL 1.
15. DIMENSIONS ARE IN INCHES [MILLIMETERS] WITH THE FOLLOWING TOLERANCES: [MILLIMETERS] ARE FOR REFERENCE ONLY.
.XX = ±.02 [±0.5]
.XXX = ±.010 [±0.25]

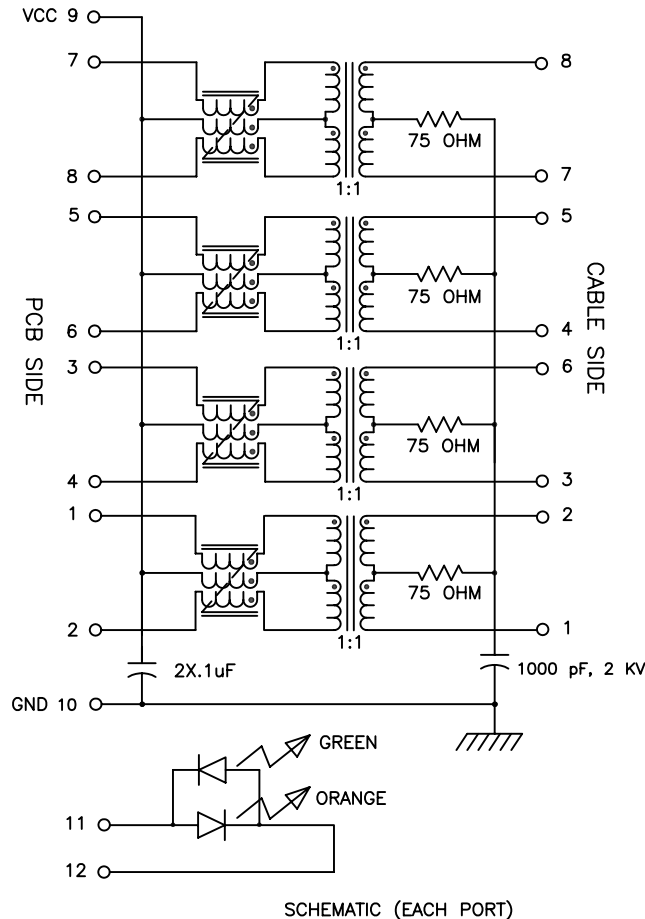

ELECTRICAL CHARACTERISTICS AT +25°C UNLESS OTHERWISE SPECIFIED
(FOR REFERENCE ONLY. USED FOR CUSTOMER INFORMATION.)

PARAMETER	SPECIFICATIONS	
OPERATING TEMP	0°C - 70°C	
URNS RATIO	1.00 ± 2%	
POLARITY	PER SCHEMATIC	
INSERTION LOSS	100 KHz	1-125 MHz
	-1.2 dB MAX	-0.2-0.002*f ^{1.4} dB MAX
RETURN LOSS (Z OUT = 100 OHM ±15%)	.1-40 MHz	40-100 MHz
	-16 dB MIN	-10+20*LOG ₁₀ (f/80 MHz) dB MIN
INDUCTANCE (OCL) (MEDIA SIDE, 0°C-70°C)	350 uH MIN (MEASURED AT 100 KHz, 100 mVRMS AND WITH 8 mA DC BIAS)	
CROSSTALK, ADJACENT CHANNELS	1 MHz	10-100 MHz
	-50 dB MIN	-55+22*LOG ₁₀ (f/10) dB MIN
COMMON MODE REJECTION RATIO	2 MHz	30-200 MHz
	-50 dB MIN	-15+20*LOG ₁₀ (f/200) dB MIN
DC RESISTANCE, 1/2 WINDING	.65 OHMS MAX	
DCR IMBALANCE	±.065 OHMS MAX (CENTER TAP SYMMETRY)	
INPUT - OUTPUT ISOLATION	2250 VDC MIN @ 60 SECONDS	

NOTE: f IS FREQUENCY IN MHZ.

EMMITTED COLOR	GREEN	ORANGE
WAVELENGTH (If=20ma)	568 nm	610 nm
BRIGHTNESS - TYP (mCD) If (ma)	8.5	6
	20	20
VIEWING ANGLE	100°	100°
POWER DISSIPATION (Pd)	100 mW MAX	80 mW MAX
PEAK FORWARD CURRENT (10 us PULSE)	150 mA MAX	150 mA MAX
FORWARD VOLTAGE (Vf) (If=20 ma)	2.2 TO 2.6 VOLTS	2.2 TO 2.6 VOLTS

NOTE: PER VENDOR'S SPECIFICATIONS

© Copyright, 2010. Pulse Electronics Corp. All rights reserved. Drawing specifications subject to change without notice. (02/11/11)

PULSE CONFIDENTIAL & PROPRIETARY	PRODUCT DESCRIPTION	PS DRAWING	SHEET:	DWG. NO./ PART NO.	REV.
	CONN,RJ45,2X8,1GD,1:1,TY	PS-2316.412-C	1	JC0-0319NL	M15

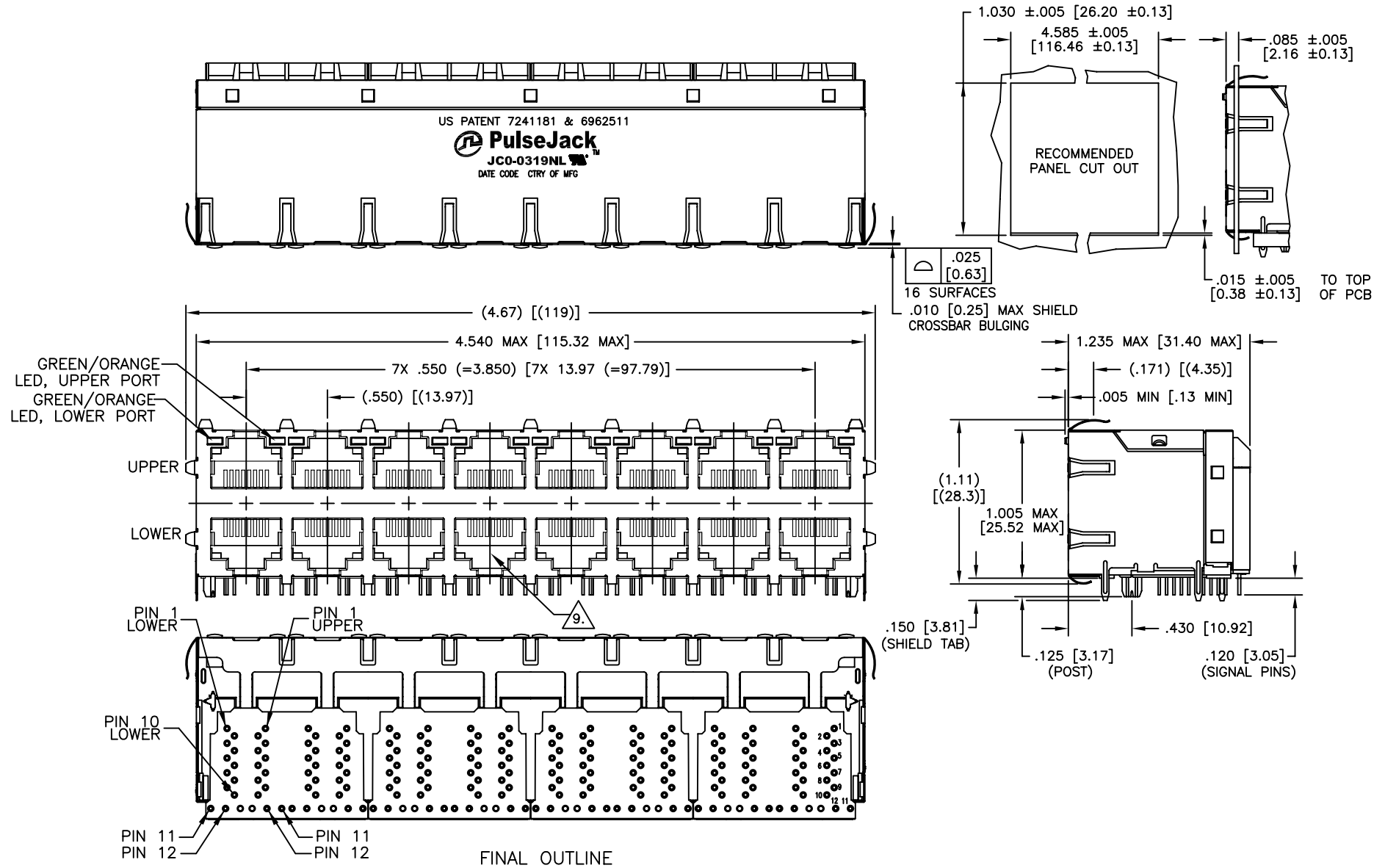

© Copyright, 2010. Pulse Electronics Corp. All rights reserved. Drawing specifications subject to change without notice. (02/11/11)

PULSE CONFIDENTIAL & PROPRIETARY	PRODUCT DESCRIPTION	PS DRAWING	SHEET:	DWG. NO./ PART NO.	REV.
	CONN,RJ45,2X8,1GD,1:1,TY	PS-2316.412-C	2	JCO-0319NL	M15

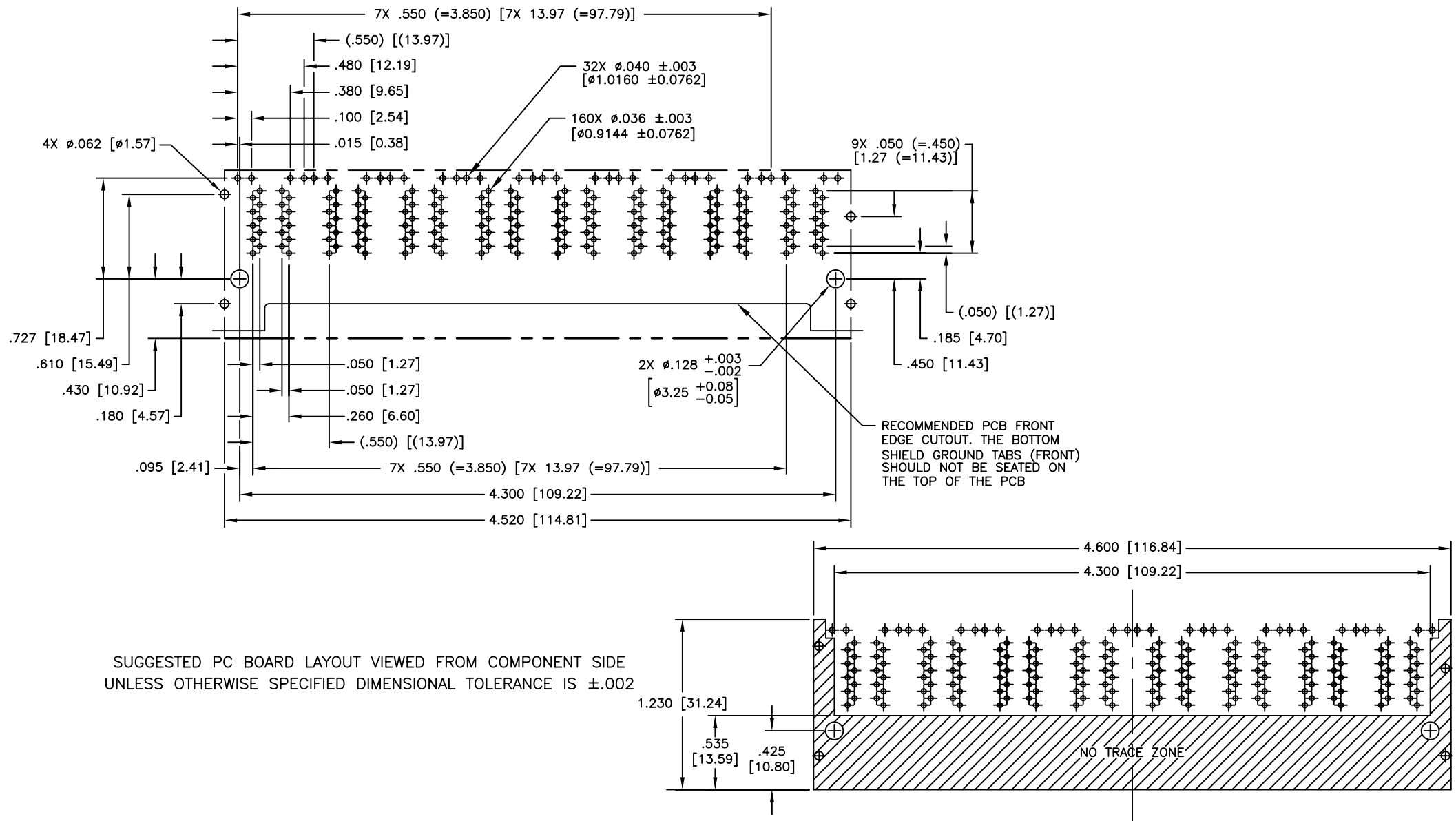

© Copyright, 2010. Pulse Electronics Corp. All rights reserved. Drawing specifications subject to change without notice. (02/11/11)

PULSE CONFIDENTIAL & PROPRIETARY	PRODUCT DESCRIPTION	PS DRAWING	SHEET:	DWG. NO./ PART NO.	REV.
		CONN,RJ45,2X8,1GD,1:1,TY	PS-2316.412-C	3	JC0-0319NL