

REVISION INFORMATION			
Rev.	Rev. Date	Modified By	Brief Description
A/0	17-10-06	T1006A	NEW DRAWING

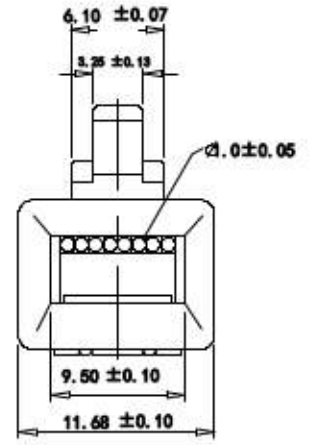
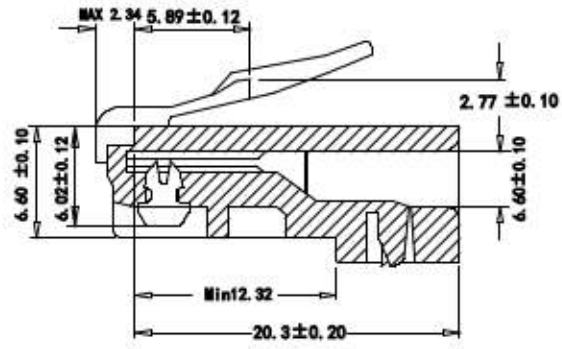
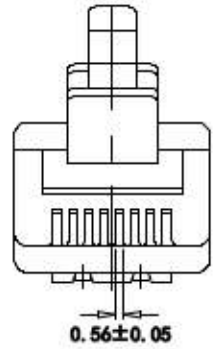
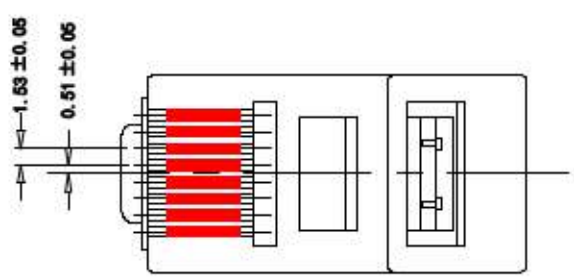

SPECIFICATIONS

HOUSING	POLY CARBONATE (PC) UL94V2
CONTACT BLADE	HIGH STRENGTH COPPER ALLLOY
MATERIAL	100 MICRON NICKEL UNDERPLATED
PLATING TYPE	8% PHOSPHOR BRONZE
PLATING THICKNESS:	GOLD PLATED 50U"
OPERATING TEMP	-40° C TO 125° C
CURRENT RATING	250V AC MAX AT 2A
DIELECTRIC	500V AC
INSULATION RES	500MEGAOHMS

PART NO	DRAWING NO		
5010-FU0088-005	671-433		

CnC Tech, LLC
Industrial Cable and Connector Technology

DRAWN BY:	DATE: 2017/10/06	DESCRIPTION: MP8P8C 50U" PLUG P
CHECKED BY:	SHEET 1 of 1	PART NO: 5010-FU0088-005
APPROVED BY:	SCALE 1:1	REV. A/0 UNIT: mm

ROHS compliant