



AK4137

32bit SRC with PCM/DSD conversion

1. General Description

The AK4137 is a 2ch digital sample rate converter (SRC). The input sample rate ranges from 8kHz to 768kHz. The output sample rate is from 8kHz to 768kHz. The AK4137 has an internal Oscillator. Therefore it does not need any external master clocks and simplifies a system configuration. The AK4137 is suitable for the application interfacing to different sample rates such as high-end Audio Systems and USB-DACs. It is capable of playing back various audio formats with PCM-DSD data conversion function.

2. Features

- 2 channels input/output
- Asynchronous Sample Rate Converter
- PCM
 - Input Sample Rate Range (FSI): 8kHz~768kHz
 - Output Sample Rate Range (FSO): 8kHz~768kHz
- Input to Output Sample Rate Ratio: FSO/FSI = 1/6 ~ 24
- DSD
 - Input Sample Rate Range (FSI): 2.8224MHz~12.288MHz
 - Output Sample Rate Range (FSO): 2.8224MHz~12.288MHz
- Input to Output Sample Rate Ratio: FSO/FSI = 1/6 ~ 24
- THD+N: Up to -150dB
- Dynamic Range: 186dB (A-weighted)
- I/F format: MSB justified, LSB justified, I²S compatible and TDM
- PCM/DSD converter
- DoP I/F
- Oscillator for Internal Operation Clock
- Clock for Master mode: 64/128/192/256/384/512/768fso
- On-chip X' tal oscillator
- Digital De-emphasis Filter (32kHz, 44.1kHz, 48kHz)
- Soft Mute Function
- SRC Bypass mode (Master/Slave, PCM, DSD)
- uP Interface: I2C bus/SPI 4-wire
- Power Supply
 - DVDD: 3.0~3.6V (internal LDO enabled)
 - DVDD: 1.7~1.9V (internal LDO disabled)
- Operating Temperature: Ta= -40 ~ +105°C
- Package
 - 48-pin LQFP (0.5mm pitch)

3. Table of Contents

1. General Description	1
2. Features	1
3. Table of Contents	2
4. Block Diagram	5
5. Pin Configurations and Functions	6
■ Pin Functions	7
6. Absolute Maximum Ratings	11
7. Recommended Operation Conditions	11
8. SRC Characteristics	12
■ PCMIN → PCMOUT	12
■ PCMIN → DSDOUT	12
■ DSDIN → PCMOUT	13
9. Power Consumptions	14
■ Internal LDO Mode	14
■ DV18 External Supply Mode	14
10. Filter Characteristics	15
■ Sharp Roll-Off Filter Characteristics	15
■ Slow Roll-Off Filter Characteristics	16
■ Short Delay Sharp Roll-Off Filter Characteristics	17
■ Short Delay Slow Roll-Off Filter Characteristics	18
11. DSD Mode Characteristics	19
■ Sharp Roll-Off Filter Characteristics	19
■ Slow Roll-Off Filter Characteristics	19
■ Short Delay Sharp Roll-Off Filter Characteristics	20
■ Short Delay Slow Roll-Off Filter Characteristics	20
12. Input and Output Examples	21
13. DC Characteristics	23
14. Switching Characteristics	23
■ Timing Diagrams	29
15. Functional Descriptions	37
■ Operation Mode and Setting	37
■ Power-up Sequence	38
■ SRC Bypass Mode	39
■ Slave Mode	41
■ Master Mode	41
■ System Clock and Audio Interface Format for Input PORT	42
■ System Clock for Output PORT	46
■ Audio Interface Format for Output PORT	48
■ Cascade Connection in TDM Mode	53
■ Soft Mute Function	54
■ Dither Circuit	56
■ Digital Filter	57
■ De-emphasis Filter	57
■ Regulator	57
■ DSD Mode	58
■ System Reset	60
■ Internal Reset Function for Clock Change	61
■ When the frequency of ILRCK at input port is changed without a reset by the PDN pin or RSTN bit	62
■ When the frequency of OLRCK at output port is changed without a reset by the PDN pin or RSTN bit	62
■ Pop Noise Reduction in Sampling Rate Conversion	62
■ Input Source Switching (PCM↔DSDI, DoP Mode)	63
■ Internal Status Pin	63

■ Serial Control Interface	64
■ Register Map	68
■ Grounding and Power Supply Decoupling	74
16. Jitter Tolerance	75
17. Recommended External Circuit	76
18. Package.....	78
■ Outline Dimensions	78
■ Material & Lead Finish.....	78
■ Marking	79
19. Ordering Guide.....	79
■ Ordering Guide	79
20. Revision History.....	80
IMPORTANT NOTICE.....	82

	AK4137	AK4136
Bit	32	←
DR (A-Weighted)	186	176
THD+N	150	140
fsi	8~768KHz	8~384KHz
fso	8~768KHz	8~384KHz
Ratio I/O	1/6~24	1/6~12
Output Clock (Master Mode Operation)	64/128/256/384/512/768fso	128/256/384/512/768fso
SRC Conversion	PCM→PCM, DSD→DSD DSD→PCM, PCM→DSD DoP→DSD, DoP→PCM	PCM→PCM conversion only
SRC Bypass Function	Available (Master, Slave)	←
Soft Mute	Available Semi-Auto Mode Mute Time Setting Adjustment	Available Semi-Auto Mode and Mute Time Adjustment are only available by register settings.
DITHER	Available	Available (only by register settings)
Internal Regulator	3V→1.8V	←
External 1.8V Input	Available	←
Crystal Oscillator	Available	←
Pop Noise reduction on Rate Switching	Available	←
Micro Controller I/F	I2C, 4-Wire	←

4. Block Diagram

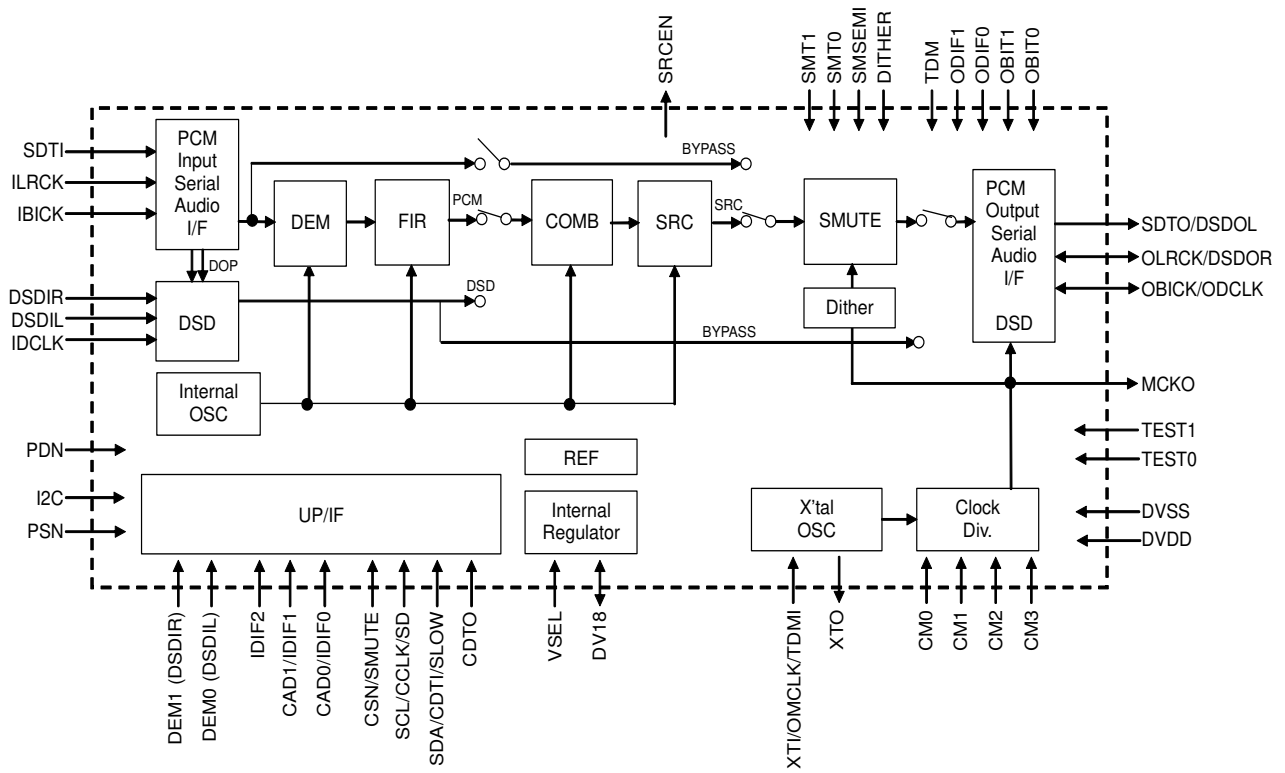

Figure 1. Block Diagram

5. Pin Configurations and Functions

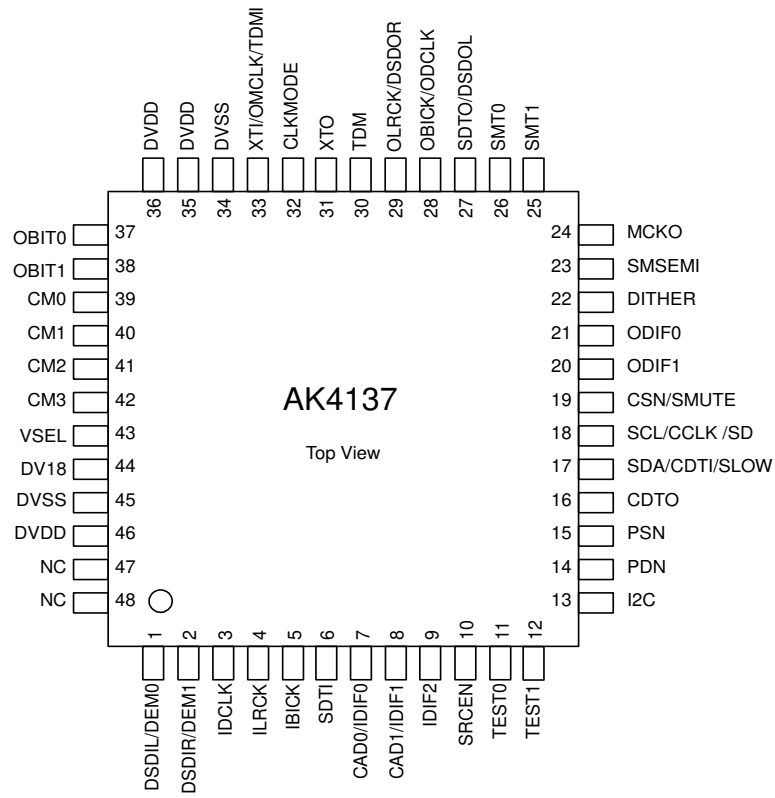

Figure 2. Pin Layout

■ Pin Functions

No.	Pin Name	I/O	Function
1	DSDIL	I	DSD Data Pin in DSD Mode
	DEM0	I	De-emphasis Control #0 Pin
2	DSDIR	I	DSD Data Pin in DSD Mode
	DEM1	I	De-emphasis Control #1 Pin
3	IDCLK	I	DSD Clock Pin in DSD Mode
4	ILRCK	I	L/R Clock Pin in PCM Mode
5	IBICK	I	Audio Serial Data Clock Pin in PCM Mode
6	SDTI	I	Audio Serial Data Input Pin in PCM Mode
7	CAD0	I	Chip Address 0 Pin in Serial Control Mode
	IDIF0	I	Digital Input Format 0 Pin in Parallel Control Mode
8	CAD1	I	Chip Address 1 Pin in Serial Control Mode
	IDIF1	I	Digital Input Format 1 Pin in Parallel Control Mode
9	IDIF2	I	Digital Input Format 2 Pin in Parallel Control Mode
10	SRCEN	O	Unlock Status Pin When the PDN pin= "L", this pin outputs "H".
11	TEST0	I	Test pin 0. Must be connected to DVSS in normal use.
12	TEST1	I	Test pin 1. Must be connected to DVSS in normal use.
13	I2C	I	Select serial mode "L": 4-wire serial Mode , "H": I2C Mode
14	PDN	I	Power-Down Mode Pin "H": Power up, "L": Power down reset and initializes the control register. The AK4137 should be reset once by bringing PDN pin = "L" upon power-up.
15	PSN	I	Parallel/Serial Mode Select. "L": Serial Mode , "H": Parallel Mode

Note 1. All input pins must not be allowed to float. DVDD must be connected to the same power supply.
 Note 2. PSN, CM3-0, OBIT1-0, TDM, ODIF1-0, IDIF2-0 and CAD1-0 pin must be changed when the PDN pin = "L".

No.	Pin Name	I/O	Function
16	CDTO	O	I2C= "L": Control Data Output Pin in Serial Control Mode
17	SDA	I/O	I2C= "H": Control Data In/Out Pin in Serial Control Mode
	CDTI	I	I2C= "L": Control Data Input Pin in Serial Control Mode
18	SLOW	I	Digital Filter Select Pin in Parallel Control Mode
	SCL	I	I2C= "H": Control Data Clock Input Pin in Serial Control Mode
	CCLK	I	I2C= "L": Control Data Clock Pin in Serial Control Mode
19	SD	I	Digital Filter Select Pin in Parallel Control Mode
	CSN	I	Chip Select Pin in Serial Control Mode , I2C= "L"
20	SMUTE	I	Soft Mute Pin in Parallel Control Mode When this pin is changed to "H", soft mute cycle is initiated. When returning "L", the output mute releases.
	ODIF1	I	Audio Interface Format #1 Pin for Output PORT
21	ODIF0	I	Audio Interface Format #0 Pin for Output PORT
22	DITHER	I	Dither Enable Pin "H": Dither ON, "L": Dither OFF
23	SMSEMI	I	Soft Mute Semi Auto Mode "L": Manual Mode , "H": Semi Auto Mode
24	MCKO	O	Master Clock Output Pin
25	SMT1	I	Soft Mute Timer select #1 Pin
26	SMT0	I	Soft Mute Timer select #0 Pin
27	SDTO	O	Audio Serial Data Output Pin for Output PORT When the PDN pin = "L", the SDTO pin outputs "L".
	DSDOL	O	DSD Data Pin in DSD Mode
28	OBICK	I/O	Audio Serial Data Clock Pin for Output PORT When the PDN pin = "L" in master mode, the OBICK pin outputs "L".
	ODCLK	I/O	DSD Clock Pin in DSD Mode
29	OLRCK	I/O	Output Channel Clock Pin for Output PORT When the PDN pin = "L" in master mode, the OLRCK pin outputs "L".
	DSDOR	O	DSD Data Pin in DSD Mode
30	TDM	I	TDM Format Select Pin "L"(connected to DVSS): Stereo Mode "H"(connected to DVDD): TDM mode for Output
31	XTO	O	X'tal Output Pin When the PDN pin = "L" or CM3-0 = "LHHL" or "LHHH" or "Hxxx" XTO outputs "L".
32	CLKMODE	I	Master Clock Select Pin "L"(connected to DVSS): X'tal Mode "H"(connected to DVDD): External Master Clock or TDM="H"

Note 1. All input pins must not be allowed to float. DVDD must be connected to the same power supply.

Note 2. PSN, CM3-0, OBIT1-0, TDM, ODIF1-0, IDIF2-0 and CAD1-0 pin must be changed when the PDN pin = "L".

No.	Pin Name	I/O	Function
33	XTI	I	X'tal Input Pin
	OMCLK	I	External Master Clock Input
	TDMI	I	TDMI Daisy-Chain Input Pin
34	DVSS	-	Digital Ground Pin
35	DVDD	-	Digital Power Supply Pin, 3.0 ~ 3.6V or 1.7 ~ 1.9V
36	DVDD	-	Digital Power Supply Pin, 3.0 ~ 3.6V or 1.7 ~ 1.9V
37	OBIT0	I	Bit Length Select #0 Pin for Output Data
38	OBIT1	I	Bit Length Select #1 Pin for Output Data
39	CM0	I	Clock Select or Mode Select #0 Pin for Output PORT
40	CM1	I	Clock Select or Mode Select #1 Pin for Output PORT
41	CM2	I	Clock Select or Mode Select #2 Pin for Output PORT
42	CM3	I	Clock Select or Mode Select #3 Pin for Output PORT
43	VSEL	I	Digital Power select "L": DV18 is Output pin, "H": DV18 is Power Supply Pin
44	DV18	I/O	Digital Power Pin, Typ 1.8V VSEL= "L", Output When the PDN pin= "L", the DV18 pin outputs "L". Current must not be taken from this pin. A 10 μ F (\pm 30%; including the temperature characteristics) capacitor should be connected between this pin and DVSS. When this capacitor is polarized, the positive polarity pin should be connected to the DV18 pin. VSEL= "H", Input
45	DVSS	-	Digital Ground Pin
46	DVDD	-	Digital Power Supply Pin, 3.0 ~ 3.6V or 1.7 ~ 1.9V
47	NC	-	This pin must be connected to DVSS.
48	NC	-	This pin must be connected to DVSS.

Note 1. All input pins must not be allowed to float. DVDD must be connected to the same power supply.

Note 2. PSN, CM3-0, OBIT1-0, TDM, ODIF1-0, IDIF2-0 and CAD1-0 pin must be changed when the PDN pin = "L".

*Unused Input/Output Pins

Classification	Pin Name	Setting
Digital	SMSEMI, DITHER, CSN/SMUTE	Connect to DVSS
	XTI/OMCLK/TDMI	Connect to DVSS (Slave Mode)
	SRCEN, MCKO, XTO, CDTO	Open

*The status of OLRCK and OBICK pins, when the PDN pin = "L", are shown below. ("L" output in Master mode) When the CM3 pin = "H", the AK4137 is always in output mode.

Setting Pins				OLRCK, OBICK
CM3	CM2	CM1	CM0	
L	L	L	L	"L" Output
L	L	L	H	
L	L	H	L	
L	L	H	H	
L	H	L	L	Input
L	H	L	H	"L" Output
L	H	H	L	
L	H	H	H	
H	-	-	-	

* The output pin status when the PDN pin = "L" is shown below.

Output Pin	Status
SDTO	"L" Output
SRCEN	"H" Output
MCKO	"L" Output
XTO	"L" Output
CDTO	Hi-z

6. Absolute Maximum Ratings

(DVSS=0V; [Note 3](#))

Parameter		Symbol	Min.	Max.	Unit
Power Supplies	Digital	DVDD	-0.3	4.3	V
	(Internal Digital) (Note 4)	DV18	-0.3	2.5	V
Input Current, Any Pin Except Supplies		IIN	-	±10	mA
Digital Input Voltage (Note 5)		VDIN	-0.3	(DVDD+0.3) or 4.3	V
Ambient Temperature (Power applied) (Note 6)		Ta	-40	105	°C
Storage Temperature		Tstg	-65	150	°C

Note 3. All voltages are with respect to ground.

Note 4. DVSS must be connected to the same ground.

Note 5. DSDIL/DEM0, DSDIR/DEM1, ILRCK, IBICK, DCLK, SDTI, IDIF0/CAD0, IDIF1/CAD1, IDIF2, PDN, PSN, I2C, SLOW/CDTI/SDA, SD/CCLK/SCL, SMUTE/CSN, SMSEMI, SMT1-0, OBIT1-0, ODIF1-0, CM3-0, DITHER, VSEL and TEST1-0 pins. Regarding Digital Input pins, maximum value which is lower value (DVDD + 0.3) or 4.3 V.

Note 6. In the case that the PCB wiring density is more than 100%

WARNING: Operation at or beyond these limits may result in permanent damage to the device.
Normal operation is not guaranteed at these extremes.

7. Recommended Operation Conditions

(DVSS=0V; [Note 3](#); VSEL= "L")

Parameter		Symbol	Min.	Typ.	Max.	Unit
Power Supplies	Digital	DVDD	3.0	3.3	3.6	V

(DVSS=0V; [Note 3](#); VSEL= "H")

Parameter		Symbol	Min.	Typ.	Max.	Unit
Power Supplies (Note 7)	Digital	DVDD	1.7	1.8	1.9	V
	Digital	DV18	1.7	1.8	1.9	V
	Difference	DVDD- DV18	-	0	-	V

Note 3. All voltages are with respect to ground.

Note 7. DVDD and DV18 should be connected externally.

The PDN pin must be "L" when power up the AK4137. Set the PDN pin to "H" after all power supplies are ON. Writing by a microcontroller should be executed with a 5ms interval after the PDN pin = "H".

8. SRC Characteristics

■ PCMIN → PCMOUT

(Ta=-40~ +105°C; DVDD=3.0~3.6V or DVDD=DV18=1.7V~1.9V; DVSS=0V; Signal Frequency=1kHz; data = 32bit; measurement bandwidth = 20Hz~ FSO/2; unless otherwise specified.)

Parameter	Symbol	Min.	Typ.	Max.	Unit
Resolution				32	Bits
Input Sample Rate	FSI	8		768	kHz
Output Sample Rate	FSO	8		768	kHz
THD+N (Input=1kHz, 0dBFS)					
FSO/FSI=48kHz/48kHz		-	-150	-	dB
FSO/FSI=48kHz/44.1kHz		-	-133	-	dB
FSO/FSI=48kHz/192kHz		-	-153	-	dB
FSO/FSI=192kHz/48kHz		-	-144	-	dB
Worst Case (FSO/FSI=32kHz/176.4kHz)		-	-	-111	dB
Dynamic Range (Input=1kHz, -60dBFS)					
FSO/FSI=48kHz/48kHz		-	184	-	dB
FSO/FSI=48kHz/44.1kHz		-	183	-	dB
FSO/FSI=48kHz/192kHz		-	184	-	dB
FSO/FSI=192kHz/48kHz		-	184	-	dB
Worst Case (FSO/FSI=32kHz/176.4kHz)		176	-	-	dB
Dynamic Range (Input=1kHz, -60dBFS, A-weighted)					
FSO/FSI=8kHz/48kHz		-	186	-	dB
Ratio between Input and Output Sample Rate	FSO/FSI	1/6		24	-

■ PCMIN → DSDOUT

(Ta=-40~ +105°C; DVDD=3.0~3.6V or DVDD=VD18=1.7~1.9V; DVSS=0V; Signal Frequency=1kHz; data = 32bit; measurement bandwidth = 20Hz~ FSO/2; unless otherwise specified.)

Parameter	Symbol	Min.	Typ.	Max.	Unit
Resolution				32	Bits
Input Sample Rate	FSI	8		768	kHz
Output Sample Rate	FSO	44.1		48	kHz
THD+N (Input= 1kHz, 0dBFS, Note 8)					
64FSO/FSI=2.8224MHz/44.1kHz		-	-115	-	dB
128FSO/FSI=5.6448MHz/44.1kHz		-	-119	-	dB
256FSO/FSI=11.2896MHz/176.4kHz		-	-123	-	dB
Dynamic Range (Input= 1kHz, -60dBFS, Note 8)					
64FSO/FSI=2.8224MHz/44.1kHz		-	116	-	dB
128FSO/FSI=5.6448MHz/44.1kHz		-	119	-	dB
256FSO/FSI=11.2896MHz/176.4kHz		-	123	-	dB
Ratio between Input and Output Sample Rate	FSO/FSI	1/16		1	-

Note 8. OGAINM6 bit = "1"

■ DSDIN → PCMOUT

($T_a = -40 \sim +105^\circ\text{C}$; $DVDD = 3.0 \sim 3.6\text{V}$ or $DVDD = VD18 = 1.7 \sim 1.9\text{V}$; $DVSS = 0\text{V}$; Signal Frequency = 1kHz; data = 32bit; measurement bandwidth = 20Hz ~ FSO/2; unless otherwise specified.)

Parameter	Symbol	Min.	Typ.	Max.	Unit
Resolution				32	Bits
Input Sample Rate	FSI	44.1		48	kHz
Output Sample Rate	FSO	44.1		768	kHz
THD+N (Input=1kHz, -6dBFS, Note 9)					
FSO/64FSI=44.1kHz/2.8224MHz		-	-98	-	dB
FSO/128FSI=44.1kHz/5.6448MHz		-	-115	-	dB
FSO/256FSI=44.1kHz/11.2896MHz		-	-115	-	dB
Dynamic Range (Input=1kHz, -60dBFS, Note 9)					
FSO/64FSI=44.1kHz/2.8224MHz		-	108	-	dB
FSO/128FSI=44.1kHz/5.6448MHz		-	140	-	dB
FSO/256FSI=44.1kHz/11.2896MHz		-	132	-	dB
Dynamic Range (Input=1kHz, -60dBFS, A-weighted, Note 9)					dB
FSO/128FSI=44.1kHz/5.6448MHz		-	142	-	
Ratio between Input and Output Sample Rate	FSO/FSI	1		17.4	-

Note 9. I_GAINM6 bit = "1". It is defined that DSD outputs of the AK4137 are source.

■ DSDIN → DSDOUT

($T_a = -40 \sim +105^\circ\text{C}$; $DVDD = 3.0 \sim 3.6\text{V}$ or $DVDD = VD18 = 1.7 \sim 1.9\text{V}$; $DVSS = 0\text{V}$; Signal Frequency = 1kHz; data = 32bit; measurement bandwidth = 20Hz ~ FSO/2; unless otherwise specified.)

Parameter	Symbol	Min.	Typ.	Max.	Unit
Resolution				32	Bits
Input Sample Rate	FSI	44.1		48	kHz
Output Sample Rate	FSO	44.1		48	kHz
THD+N (Input=1kHz, -6dBFS, Note 10)					
64FSO/64FSI=2.8224MHz/2.8224MHz		-	-111	-	dB
128FSO/128FSI=5.6448MHz/5.6448MHz		-	-115	-	dB
256FSO/256FSI=11.2896MHz/11.2896MHz		-	-115	-	dB
Dynamic Range (Input=1kHz, -60dBFS, Note 10)					
64FSO/64FSI=2.8224MHz/2.8224MHz		-	116	-	dB
128FSO/128FSI=5.6448MHz/5.6448MHz		-	119	-	dB
256FSO/256FSI=11.2896MHz/11.2896MHz		-	123	-	dB
Ratio between Input and Output Sample Rate	FSO/FSI	1		1	-

Note 10. *I_GAINM6 bit = "1", O_GAINM6 bit = "1"

9. Power Consumptions

■ **Internal LDO Mode**

(Ta=-40~ +105°C; DVDD=3.0~3.6V)

Parameter	Symbol	Min.	Typ.	Max.	Unit
Power Supply Current Normal operation: (PDN = "H") FSI=FSO=48kHz at Master Mode : DVDD=3.3V FSI=FSO=192kHz at Master Mode: DVDD=3.3V FSI=FSO=768kHz at Master Mode: DVDD=3.3V : DVDD=3.6V			11 33 40	- - 60	mA mA mA mA
Power down: PDN = "L" (Note 11) DVDD=3.6V			10	100	μA

Note 11. All digital inputs including clock pins are held to DVSS.

■ **DV18 External Supply Mode**

(Ta=-40~ +105°C; DVDD=DV18=1.7~1.9V)

Parameter	Symbol	Min.	Typ.	Max.	Unit
Power Supply Current Normal operation: FSI=FSO=48kHz at Master Mode : DVDD=DV18=1.8V FSI=FSO=192kHz at Master Mode: DVDD=DV18=1.8V FSI=FSO=768kHz at Master Mode: DVDD=DV18=1.8V : DVDD=DV18=1.9V			11 28 32	- - 50	mA mA mA mA
Power down: PDN = "L" (Note 11) DVDD=DV18=1.9V			10	100	μA

Note 11. All digital inputs including clock pins are held to DVSS.

10. Filter Characteristics

■ Sharp Roll-Off Filter Characteristics

(Ta=-40~ +105°C; DVDD=3.0~3.6V or DVDD=DV18=1.7V~1.9V, DVSS=0V)

Parameter	Symbol	Min.	Typ.	Max.	Unit	
Digital Filter						
Passband -0.01dB	$0.985 \leq \text{FSO/FSI} \leq 24.000$	PB	0	-	0.4583FSI	kHz
	$0.905 \leq \text{FSO/FSI} < 0.985$	PB	0	-	0.4167FSI	kHz
	$0.714 \leq \text{FSO/FSI} < 0.905$	PB	0	-	0.3195FSI	kHz
	$0.656 \leq \text{FSO/FSI} < 0.714$	PB	0	-	0.2852FSI	kHz
	$0.536 \leq \text{FSO/FSI} < 0.656$	PB	0	-	0.2182FSI	kHz
	$0.492 \leq \text{FSO/FSI} < 0.536$	PB	0	-	0.2177FSI	kHz
	$0.452 \leq \text{FSO/FSI} < 0.492$	PB	0	-	0.1948FSI	kHz
	$0.357 \leq \text{FSO/FSI} < 0.452$	PB	0	-	0.1458FSI	kHz
	$0.324 \leq \text{FSO/FSI} < 0.357$	PB	0	-	0.1302FSI	kHz
	$0.246 \leq \text{FSO/FSI} < 0.324$	PB	0	-	0.0917FSI	kHz
	$0.226 \leq \text{FSO/FSI} < 0.246$	PB	0	-	0.0826FSI	kHz
	$0.1667 \leq \text{FSO/FSI} < 0.226$	PB	0	-	0.0583FSI	kHz
Stopband	$0.985 \leq \text{FSO/FSI} \leq 24.000$	SB	0.5417FSI	-	-	kHz
	$0.905 \leq \text{FSO/FSI} < 0.985$	SB	0.5021FSI	-	-	kHz
	$0.714 \leq \text{FSO/FSI} < 0.905$	SB	0.3965FSI	-	-	kHz
	$0.656 \leq \text{FSO/FSI} < 0.714$	SB	0.3643FSI	-	-	kHz
	$0.536 \leq \text{FSO/FSI} < 0.656$	SB	0.2974FSI	-	-	kHz
	$0.492 \leq \text{FSO/FSI} < 0.536$	SB	0.2813FSI	-	-	kHz
	$0.452 \leq \text{FSO/FSI} < 0.492$	SB	0.2604FSI	-	-	kHz
	$0.357 \leq \text{FSO/FSI} < 0.452$	SB	0.2116FSI	-	-	kHz
	$0.324 \leq \text{FSO/FSI} < 0.357$	SB	0.1969FSI	-	-	kHz
	$0.246 \leq \text{FSO/FSI} < 0.324$	SB	0.1573FSI	-	-	kHz
	$0.226 \leq \text{FSO/FSI} < 0.246$	SB	0.1471FSI	-	-	kHz
	$0.1667 \leq \text{FSO/FSI} < 0.226$	SB	0.1020FSI	-	-	kHz
Passband Ripple	$0.226 \leq \text{FSO/FSI} \leq 24.000$	PR		-	±0.01	dB
	$0.1667 \leq \text{FSO/FSI} < 0.226$	PR		-	±0.03	dB
Stopband Attenuation	$0.985 \leq \text{FSO/FSI} \leq 24.000$	SA	140.2	-	-	dB
	$0.905 \leq \text{FSO/FSI} < 0.985$	SA	140.9	-	-	dB
	$0.714 \leq \text{FSO/FSI} < 0.905$	SA	135.2	-	-	dB
	$0.656 \leq \text{FSO/FSI} < 0.714$	SA	135.1	-	-	dB
	$0.536 \leq \text{FSO/FSI} < 0.656$	SA	133.5	-	-	dB
	$0.492 \leq \text{FSO/FSI} < 0.536$	SA	115.3	-	-	dB
	$0.452 \leq \text{FSO/FSI} < 0.492$	SA	118.2	-	-	dB
	$0.357 \leq \text{FSO/FSI} < 0.452$	SA	123.3	-	-	dB
	$0.324 \leq \text{FSO/FSI} < 0.357$	SA	122.9	-	-	dB
	$0.246 \leq \text{FSO/FSI} < 0.324$	SA	117.9	-	-	dB
Group Delay (Note 12)		GD	-	64	-	1/fs

Note 12. This is the time from a rising edge of ILRCK after L and R channels data is input to a rising edge of OLRCK before the L and R channels data is output, when there is no phase difference between input and output data.

■ Slow Roll-Off Filter Characteristics

($T_a = -40 \sim +105^\circ\text{C}$; $DVDD = 3.0 \sim 3.6\text{V}$ or $DVDD = DV18 = 1.7\text{V} \sim 1.9\text{V}$, $DVSS = 0\text{V}$)

Parameter	Symbol	Min.	Typ.	Max.	Unit
Digital Filter					
Passband -0.01dB	$0.1667 \leq \text{FSO/FSI} < 24.000$	PB	0	-	0.0417FSI kHz
Stopband	$0.1667 \leq \text{FSO/FSI} < 24.000$	SB	0.4167FSI	-	- kHz
Passband Ripple		PR	-	-	± 0.01 dB
Stopband Attenuation		SA	-	108.1	- dB
Group Delay	(Note 12)	GD	-	64	- 1/fs

Note 12. This is the time from a rising edge of ILRCK after L and R channels data is input to a rising edge of OLRCK before the L and R channels data is output, when there is no phase difference between input and output data.

■ Short Delay Sharp Roll-Off Filter Characteristics

(Ta=-40~ +105°C; DVDD=3.0~3.6V or DVDD=DV18=1.7V~1.9V, DVSS=0V)

Parameter	Symbol	Min.	Typ.	Max.	Unit	
Digital Filter						
Passband -0.01dB	$0.985 \leq \text{FSO/FSI} \leq 24.000$	PB	0	-	0.4583FSI	kHz
	$0.905 \leq \text{FSO/FSI} < 0.985$	PB	0	-	0.4167FSI	kHz
	$0.714 \leq \text{FSO/FSI} < 0.905$	PB	0	-	0.3195FSI	kHz
	$0.656 \leq \text{FSO/FSI} < 0.714$	PB	0	-	0.2852FSI	kHz
	$0.536 \leq \text{FSO/FSI} < 0.656$	PB	0	-	0.2182FSI	kHz
	$0.492 \leq \text{FSO/FSI} < 0.536$	PB	0	-	0.2177FSI	kHz
	$0.452 \leq \text{FSO/FSI} < 0.492$	PB	0	-	0.1948FSI	kHz
	$0.357 \leq \text{FSO/FSI} < 0.452$	PB	0	-	0.1458FSI	kHz
	$0.324 \leq \text{FSO/FSI} < 0.357$	PB	0	-	0.1302FSI	kHz
	$0.246 \leq \text{FSO/FSI} < 0.324$	PB	0	-	0.0917FSI	kHz
	$0.226 \leq \text{FSO/FSI} < 0.246$	PB	0	-	0.0826FSI	kHz
	$0.1667 \leq \text{FSO/FSI} < 0.226$	PB	0	-	0.0583FSI	kHz
Stopband	$0.985 \leq \text{FSO/FSI} \leq 24.000$	SB	0.5417FSI	-	-	kHz
	$0.905 \leq \text{FSO/FSI} < 0.985$	SB	0.5021FSI	-	-	kHz
	$0.714 \leq \text{FSO/FSI} < 0.905$	SB	0.3965FSI	-	-	kHz
	$0.656 \leq \text{FSO/FSI} < 0.714$	SB	0.3643FSI	-	-	kHz
	$0.536 \leq \text{FSO/FSI} < 0.656$	SB	0.2974FSI	-	-	kHz
	$0.492 \leq \text{FSO/FSI} < 0.536$	SB	0.2813FSI	-	-	kHz
	$0.452 \leq \text{FSO/FSI} < 0.492$	SB	0.2604FSI	-	-	kHz
	$0.357 \leq \text{FSO/FSI} < 0.452$	SB	0.2116FSI	-	-	kHz
	$0.324 \leq \text{FSO/FSI} < 0.357$	SB	0.1969FSI	-	-	kHz
	$0.246 \leq \text{FSO/FSI} < 0.324$	SB	0.1573FSI	-	-	kHz
	$0.226 \leq \text{FSO/FSI} < 0.246$	SB	0.1471FSI	-	-	kHz
	$0.1667 \leq \text{FSO/FSI} < 0.226$	SB	0.1020FSI	-	-	kHz
Passband Ripple	$0.226 \leq \text{FSO/FSI} \leq 24.000$	PR		-	±0.01	dB
	$0.1667 \leq \text{FSO/FSI} < 0.226$	PR		-	±0.03	dB
Stopband Attenuation	$0.985 \leq \text{FSO/FSI} \leq 24.000$	SA	140.2	-	-	dB
	$0.905 \leq \text{FSO/FSI} < 0.985$	SA	140.9	-	-	dB
	$0.714 \leq \text{FSO/FSI} < 0.905$	SA	135.2	-	-	dB
	$0.656 \leq \text{FSO/FSI} < 0.714$	SA	135.1	-	-	dB
	$0.536 \leq \text{FSO/FSI} < 0.656$	SA	133.5	-	-	dB
	$0.492 \leq \text{FSO/FSI} < 0.536$	SA	115.3	-	-	dB
	$0.452 \leq \text{FSO/FSI} < 0.492$	SA	118.2	-	-	dB
	$0.357 \leq \text{FSO/FSI} < 0.452$	SA	123.3	-	-	dB
	$0.324 \leq \text{FSO/FSI} < 0.357$	SA	122.9	-	-	dB
	$0.246 \leq \text{FSO/FSI} < 0.324$	SA	117.9	-	-	dB
	$0.226 \leq \text{FSO/FSI} < 0.246$	SA	119.7	-	-	dB
	$0.1667 \leq \text{FSO/FSI} < 0.226$	SA	90.3	-	-	dB
Group Delay (Note 12)	$0.905 \leq \text{FSO/FSI} \leq 24.000$	GD	-	20	-	1/fs
	$0.656 \leq \text{FSO/FSI} < 0.905$	GD	-	22	-	1/fs
	$0.536 \leq \text{FSO/FSI} < 0.656$	GD	-	26	-	1/fs
	$0.492 \leq \text{FSO/FSI} < 0.536$	GD	-	23	-	1/fs
	$0.452 \leq \text{FSO/FSI} < 0.492$	GD	-	24	-	1/fs
	$0.324 \leq \text{FSO/FSI} < 0.452$	GD	-	26	-	1/fs
	$0.246 \leq \text{FSO/FSI} < 0.324$	GD	-	29	-	1/fs
	$0.226 \leq \text{FSO/FSI} < 0.246$	GD	-	30	-	1/fs
$0.1667 \leq \text{FSO/FSI} < 0.226$	GD	-	32	-	1/fs	

Note 12. This is the time from a rising edge of ILRCK after L and R channels data is input to a rising edge of OLRCK before the L and R channels data is output, when there is no phase difference between input and output data.

■ Short Delay Slow Roll-Off Filter Characteristics

(Ta=-40~ +105°C; DVDD=3.0~3.6V or DVDD=DV18=1.7V~1.9V, DVSS=0V)

Parameter		Symbol	Min.	Typ.	Max.	Unit
Digital Filter						
Passband -0.01dB	$0.1667 \leq F_{SO}/F_{SI} < 24.000$	PB	0	-	$0.0417F_{SI}$	kHz
Stopband	$0.1667 \leq F_{SO}/F_{SI} < 24.000$	SB	$0.4167F_{SI}$	-	-	kHz
Passband Ripple		PR	-	-	± 0.01	dB
Stopband Attenuation		SA	-	108.1	-	dB
Group Delay (Note 12)		GD	-	21	-	1/fs

Note 12. This is the time from a rising edge of ILRCK after L and R channels data is input to a rising edge of OLRCK before the L and R channels data is output, when there is no phase difference between input and output data.

11. DSD Mode Characteristics

■ Sharp Roll-Off Filter Characteristics

(Ta=-40~ +105°C; DVDD=3.0~3.6V or DVDD=DV18=1.7V~1.9V; DVSS=0V, ILRCK=48kHz)

Parameter		Symbol	Min.	Typ.	Max.	Unit	
Digital Filter							
Passband	PCMFSO bit "00"	-0.24dB	PB	0	-	20	kHz
	PCMFSO bit "01"	-1.04dB	PB	0	-	40	kHz
	PCMFSO bit "10"	-3.86dB	PB	0	-	80	kHz
	PCMFSO bit "11"	-5.90dB	PB	0	-	100	kHz
Stopband	PCMFSO bit "00"		SB	46	-	-	kHz
	PCMFSO bit "01"		SB	66	-	-	kHz
	PCMFSO bit "10"		SB	86	-	-	kHz
	PCMFSO bit "11"		SB	126	-	-	kHz
Passband Ripple	PCMFSO bit "00"		PR	-	-	±0.2	dB
	PCMFSO bit "01"		PR	-	-	±0.5	dB
	PCMFSO bit "10"		PR	-	-	±2.0	dB
	PCMFSO bit "11"		PR	-	-	±3.0	dB
Stopband Attenuation			SA	-	112	-	dB
Group Delay (Note 14)			GD	-	15	-	1/fs

Note 13. The output level is assumed as 0dB when 1kHz, 25 ~ 75% duty range sine wave is input.

Note 14. When PCM output is 44.1kHz or 48kHz.

■ Slow Roll-Off Filter Characteristics

(Ta=-40~ +105°C; DVDD=3.0~3.6V or DVDD=DV18=1.7V~1.9V; DVSS=0V, ILRCK=48kHz)

Parameter		Symbol	Min.	Typ.	Max.	Unit
Digital Filter						
Passband	-0.28dB	PB	0	-	10	kHz
Stopband		SB	156	-	-	kHz
Passband Ripple		PR	-	-	±0.15	dB
Stopband Attenuation		SA	-	112	-	dB
Group Delay (Note 14)		GD	-	15	-	1/fs

Note 13. The output level is assumed as 0dB when 1kHz, 25 ~ 75% duty range sine wave is input.

Note 14. When PCM output is 44.1kHz or 48kHz.

■ Short Delay Sharp Roll-Off Filter Characteristics

(Ta=-40~ +105°C; DVDD=3.0~3.6V or DVDD=DV18=1.7V~1.9V; DVSS=0V, ILRCK=48kHz)

Parameter	Symbol	Min.	Typ.	Max.	Unit		
Digital Filter							
Passband	PCMFSO bit "00"	-0.24dB	PB	0	-	20	kHz
	PCMFSO bit "01"	-1.04dB	PB	0	-	40	kHz
	PCMFSO bit "10"	-3.86dB	PB	0	-	80	kHz
	PCMFSO bit "11"	-5.90dB	PB	0	-	100	kHz
Stopband	PCMFSO bit "00"		SB	46	-	-	kHz
	PCMFSO bit "01"		SB	66	-	-	kHz
	PCMFSO bit "10"		SB	86	-	-	kHz
	PCMFSO bit "11"		SB	126	-	-	kHz
Passband Ripple	PCMFSO bit "00"		PR	-	-	±0.2	dB
	PCMFSO bit "01"		PR	-	-	±0.5	dB
	PCMFSO bit "10"		PR	-	-	±2.0	dB
	PCMFSO bit "11"		PR	-	-	±3.0	dB
Stopband Attenuation	SA	-	112	-	-	dB	
Group Delay (Note 14)	GD	-	13	-	-	1/fs	

Note 13. The output level is assumed as 0dB when 1kHz, 25 ~ 75% duty range sine wave is input.

Note 14. When PCM output is 44.1kHz or 48kHz.

■ Short Delay Slow Roll-Off Filter Characteristics

(Ta=-40~ +105°C; DVDD=3.0~3.6V or DVDD=DV18=1.7V~1.9V; DVSS=0V, ILRCK=48kHz)

Parameter	Symbol	Min.	Typ.	Max.	Unit
Digital Filter					
Passband -0.28dB	PB	0	-	10	kHz
Stopband	SB	156	-	-	kHz
Passband Ripple	PR	-	-	±0.15	dB
Stopband Attenuation	SA	-	112	-	dB
Group Delay (Note 14)	GD	-	13	-	1/fs

Note 13. The output level is assumed as 0dB when 1kHz, 25 ~ 75% duty range sine wave is input.

Note 14. When PCM output is 44.1kHz or 48kHz.

12. Input and Output Examples

Possible Input and Output data combinations are shown below.

Fsi is the sampling rate of input data, and Fso is the sampling rate of output data.

Fsi[KHz]	Fso[KHz]		Fso[MHz]		
	PCM		DSD		
	min	max			
8	8	192	-	-	-
11.025	8	264.6	-	-	-
16	8	384	-	-	-
32	8	768	-	-	-
44.1	8	768	2.8224	5.6448	-
48	8	768	2.8224	5.6448	-
88.2	14.7	768	2.8224	5.6448	-
96	16	768	2.8224	5.6448	-
176.4	29.6	768	2.8224	5.6448	11.2896
192	32	768	2.8224	5.6448	11.2896

Fsi[MHz]	Fso[KHz]		Fso[MHz]		
	PCM		DSD		
	min	max			
2.8224	44.1	768	2.8224	5.6448	11.2896
5.6448	44.1	768	2.8224	5.6448	11.2896
11.2896	44.1	768	2.8224	5.6448	11.2896

Fsi[KHz]	Fso[KHz]		Fso[MHz]		
	PCM		DSD		
	min	max			
8	8	192	-	-	-
12	8	288	-	-	-
16	8	384	-	-	-
32	8	768	-	-	-
44.1	8	768	3.072	6.144	-
48	8	768	3.072	6.144	-
88.2	14.7	768	3.072	6.144	-
96	16	768	3.072	6.144	-
176.4	29.6	768	3.072	6.144	-
192	32	768	3.072	6.144	12.288

Fsi[MHz]	Fso[KHz]		Fso[MHz]		
	PCM		DSD		
	min	max			
3.072	48	768	3.072	6.144	12.288
6.144	48	768	3.072	6.144	12.288
12.288	48	768	3.072	6.144	12.288

With combinations shown below, in case down convert, THD+N will be degraded -80dB.

Fsi[KHz]	Fso[KHz]		Fso[MHz]		
PCM	PCM		DSD		
	min	max			
384	64~384	768	2.8224	5.6448	11.2896
768	128~768	768	2.8224	5.6448	11.2896

Fsi[KHz]	Fso[KHz]		Fso[MHz]		
PCM	PCM		DSD		
	min	max			
384	64~384	768	3.072	6.144	12.288
768	128~768	768	3.072	6.144	12.288

13. DC Characteristics

(Ta=-40~+105°C; DVDD=3.0~3.6V: VSEL = "L" or DVDD=DV18=1.7V~1.9V: VSEL = "H")

Parameter	Symbol	Min.	Typ.	Max.	Unit
High-Level Input Voltage	V _{IH}	70%DVDD	-	-	V
Low-Level Input Voltage	V _{IL}	-	-	30%DVDD	V
High-Level Output Voltage Except SDA pin (I _{out} =-400μA)	V _{OH}	DVDD-0.4	-	-	V
Low-Level Output Voltage Except SDA pin (I _{out} =400μA)	V _{OL}	-	-	0.4	V
SDA pin (I _{out} =3mA)	V _{OL}	-	-	0.4	V
Input Leakage Current	I _{in}	-	-	±10	μA

14. Switching Characteristics

(Ta=-40~+105°C; DVDD=3.0~3.6V: VSEL = "L" or DVDD=DV18=1.7V~1.9V: VSEL = "H"; C_L=20pF)

Parameter	Symbol	Min.	Typ.	Max.	Unit
Master Clock Timing					
Crystal Oscillator Frequency (256 times of 44.1, 48, 88.2 or 96KHz)	fXTAL	11.2896		24.576	MHz
OMCLK Input					
64 FSO :	fCLK	0.512		49.152	MHz
Pulse Width Low	tCLKL	7			ns
Pulse Width High	tCLKH	7			ns
128 FSO :	fCLK	1.024		49.152	MHz
Pulse Width Low	tCLKL	7			ns
Pulse Width High	tCLKH	7			ns
256 FSO :	fCLK	2.048		49.152	MHz
Pulse Width Low	tCLKL	7			ns
Pulse Width High	tCLKH	7			ns
384 FSO :	fCLK	3.072		36.864	MHz
Pulse Width Low	tCLKL	10			ns
Pulse Width High	tCLKH	10			ns
512 FSO :	fCLK	4.096		49.152	MHz
Pulse Width Low	tCLKL	7			ns
Pulse Width High	tCLKH	7			ns
768 FSO :	fCLK	6.144		36.864	MHz
Pulse Width Low	tCLKL	10			ns
Pulse Width High	tCLKH	10			ns
MCKO Output					
Frequency	fMCK	0.512		49.152	MHz
Duty (Note 15)	dMCLK	40	50	60	%

Note 15. This is a value of MCKO output duty when the master clock for output ports is supplied by a crystal oscillator.

Parameter	Symbol	Min.	Typ.	Max.	Unit
Input PORT ILRCK					
Frequency					kHz
Normal speed mode	FSIN	8		54	kHz
Double speed mode	FSID	54		108	kHz
Quad speed mode	FSIQ	108		216	kHz
Oct speed mode	FSIO		384		kHz
Hex speed mode	FSIH		768		kHz
Duty Cycle Slave Mode	Duty	48	50	52	%
Output PORT OLRCK					
Frequency					
Slave mode					
Normal speed mode	FSON	8		54	kHz
Double speed mode	FSOD	54		108	kHz
Quad speed mode	FSOQ	108		216	kHz
Oct speed mode	FSOO		384		kHz
Hex speed mode	FSOH		768		kHz
Master mode					
OMCLK Input, 64FSO mode	FSO	8		768	kHz
OMCLK Input, 128FSO mode	FSO	8		384	kHz
OMCLK Input, 256FSO mode	FSO	8		192	kHz
OMCLK Input, 384FSO mode	FSO	8		96	kHz
OMCLK Input, 512FSO mode	FSO	8		96	kHz
OMCLK Input, 768FSO mode	FSO	8		48	kHz
Duty Cycle					
Slave Mode	Duty	48	50	52	%
Master Mode	Duty		50		%
Input PORT ILRCK for TDM256 Mode					
Frequency	FSI	8		96	kHz
"H" time (slave mode)	tLRH	1/256FSI			ns
"L" time (slave mode)	tLRL	1/256FSI			ns
Input PORT ILRCK for TDM512 Mode					
Frequency	FSI	8		48	kHz
"H" time (slave mode)	tLRH	1/512FSI			ns
"L" time (slave mode)	tLRL	1/512FSI			ns
Output PORT OLRCK for TDM256 Mode					
Frequency	FSO	8		96	kHz
"H" time (slave mode)	tLRH	1/256 FSO			ns
"L" time (slave mode)	tLRL	1/256 FSO			ns
Output PORT OLRCK for TDM512 Mode					
Frequency	FSO	8		48	kHz
"H" time (slave mode)	tLRH	1/512 FSO			ns
"L" time (slave mode)	tLRL	1/512 FSO			ns

Parameter	Symbol	Min.	Typ.	Max.	Unit
Audio Interface Timing					
Input PORT (Slave mode)					
IBICK Period					
Normal speed mode	tBCK	1/256 FSIN			ns
Double speed mode	tBCK	1/128 FSID			ns
Quad speed mode	tBCK	1/64 FSIQ			ns
Oct speed mode	tBCK	1/64 FSIO			ns
Hex speed mode	tBCK	1/64 FSIH			ns
IBICK Pulse Width Low	tBCKL	7			ns
Pulse Width High	tBCKH	7			ns
ILRCK Edge to IBICK "↑" (Note 16)	tLRB	5			ns
IBICK "↑" to ILRCK Edge (Note 16)	tBLR	5			ns
SDTI Hold Time from IBICK "↑"	tSDH	5			ns
SDTI Setup Time to IBICK "↑"	tSDS	5			ns
DSD Audio Interface Timing (64 mode)					
IDCLK Period	tDCK	-	1/64FSIN	-	ns
IDCLK Pulse Width Low	tDCKL	160			ns
IDCLK Pulse Width High	tDCKH	160			ns
IDCLK Edge to DSDL/R	tDDD	-20		20	ns
DSD Audio Interface Timing (128 mode)					
IDCLK Period	tDCK	-	1/128FSIN	-	ns
IDCLK Pulse Width Low	tDCKL	80			ns
IDCLK Pulse Width High	tDCKH	80			ns
IDCLK Edge to DSDL/R	tDDD	-10		10	ns
DSD Audio Interface Timing (256 mode)					
IDCLK Period	tDCK	-	1/256FSIN	-	ns
IDCLK Pulse Width Low	tDCKL	40			ns
IDCLK Pulse Width High	tDCKH	40			ns
IDCLK Edge to DSDL/R	tDDD	-5		5	ns
Input PORT (TDM256 slave mode)					
IBICK Period	tBCK	40			ns
IBICK Pulse Width Low	tBCKL	16			ns
Pulse Width High	tBCKH	16			ns
ILRCK Edge to IBICK "↑" (Note 16)	tLRB	10			ns
IBICK "↑" to ILRCK Edge (Note 16)	tBLR	10			ns
SDTI Hold Time from IBICK "↑"	tSDH	10			ns
SDTI Setup Time to IBICK "↑"	tSDS	6			ns
Input PORT (TDM512 slave mode)					
IBICK Period	tBCK	40			ns
IBICK Pulse Width Low	tBCKL	16			ns
Pulse Width High	tBCKH	16			ns
ILRCK Edge to IBICK "↑" (Note 16)	tLRB	10			ns
IBICK "↑" to ILRCK Edge (Note 16)	tBLR	10			ns
SDTI Hold Time from IBICK "↑"	tSDH	10			ns
SDTI Setup Time to IBICK "↑"	tSDS	6			ns

Note 16. IBICK rising edge must not occur at the same time as ILRCK edge.

Note 17. Maximum frequency of IBICK and OBICK is 49.152MHz.

Parameter	Symbol	Min.	Typ.	Max.	Unit
Audio Interface Timing					
Output PORT (Slave mode)					
OBICK Period					
Normal speed mode	tBCK	1/256 FSON			
Double speed mode	tBCK	1/128 FSOD			
Quad speed mode	tBCK	1/64 FSOQ			
Oct speed mode	tBCK	1/64 FSOO			
Hex speed mode	tBCK	1/64 FSOH			
OBICK Pulse Width Low	tBCKL	7			ns
Pulse Width High	tBCKH	7			ns
OLRCK Edge to OBICK "↑" (Note 16)	tLRB	10			ns
OBICK "↑" to OLRCK Edge (Note 16)	tBLR	7			ns
DVDD=3.0V ~ 3.6V (VSEL pin= "L") (fso=768KHz)					
OBICK "↓" to SDTO (HEXAE bit= "1")	tBSD			5	ns
DVDD=3.0V~3.6V (VSEL pin= "L") (Except fso=768KHz)					
OLRCK to SDTO(MSB) (Except I ² S mode)	tLRS			10	ns
OBICK "↓" to SDTO	tBSD			10	ns
DVDD=1.7V~1.9V (VSEL pin= "H") (Except fso=384KHz,768KHz)					
OLRCK to SDTO(MSB) (Except I ² S mode)	tLRS			20	ns
OBICK "↓" to SDTO	tBSD			20	ns
DSD Audio Interface Timing (64 mode slave)					
ODCLK Period	tDCK	-	1/64FSIN	-	ns
ODCLK Pulse Width Low	tDCKL	160			ns
ODCLK Pulse Width High	tDCKH	160			ns
ODCLK Edge to DSDOL/R	tDDD	-20		20	ns
DSD Audio Interface Timing (128 mode slave)					
DVDD=3.0V~3.6V (VSEL pin= "L")					
ODCLK Period	tDCK	-	1/128FSIN	-	ns
ODCLK Pulse Width Low	tDCKL	80			ns
ODCLK Pulse Width High	tDCKH	80			ns
ODCLK Edge to DSDOL/R	tDDD	-10		10	ns

Note 16. IBICK rising edge must not occur at the same time as ILRCK edge.

Parameter	Symbol	Min.	Typ.	Max.	Unit
Audio Interface Timing					
Output PORT (TDM256 slave mode) DVDD=3.0V~3.6V(VSEL pin= "L")					
OBICK Period	tBCK	40			ns
OBICK Pulse Width Low	tBCKL	16			ns
Pulse Width High	tBCKH	16			ns
OLRCK Edge to OBICK "↑" (Note 16)	tLRB	10			ns
OBICK "↑" to OLRCK Edge (Note 16)	tBLR	10			ns
OBICK "↓" to SDTO	tBSD			10	ns
DVDD=1.7V~1.9V(VSEL pin= "H")					
OBICK Period	tBCK	80			ns
OBICK Pulse Width Low	tBCKL	32			ns
Pulse Width High	tBCKH	32			ns
OLRCK Edge to OBICK "↑" (Note 16)	tLRB	20			ns
OBICK "↑" to OLRCK Edge (Note 16)	tBLR	20			ns
OBICK "↓" to SDTO	tBSD			20	sn
Output PORT (TDM512 slave mode) DVDD=3.0V~3.6V(VSEL pin= "L")					
OBICK Period	tBCK	40			ns
OBICK Pulse Width Low	tBCKL	16			ns
Pulse Width High	tBCKH	16			ns
OLRCK Edge to OBICK "↑" (Note 16)	tLRB	10			ns
OBICK "↑" to OLRCK Edge (Note 16)	tBLR	10			ns
OBICK "↓" to SDTO	tBSD			10	ns
Output PORT (Master mode)					
OBICK Frequency	fBCK		64 FSO		Hz
OBICK Duty	dBCK		50		%
OBICK "↓" to OLRCK Edge	tMBLR	-5		5	ns
OBICK "↓" to SDTO	tBSD	-5		5	ns
DSD Audio Interface Timing (64 mode Master)					
ODCLK Period	tDCK		64 FSO		Hz
ODCLK Duty	dDCK		50		%
ODCLK Edge to DSDOL/R	tDDD	-20		20	ns
DSD Audio Interface Timing (128 mode Master)					
ODCLK Period	tDCK		128 FSO		Hz
ODCLK Duty	dDCK		50		%
ODCLK Edge to DSDOL/R	tDDD	-10		10	ns
DSD Audio Interface Timing (256 mode Master)					
ODCLK Period	tDCK		256 FSO		Hz
ODCLK Duty	dDCK		50		%
ODCLK Edge to DSDOL/R	tDDD	-5		-5	ns
Reset Timing					
PDN "L" Width after DVDD is on.(Note 19)	tAPD1	150			ns
PDN Accept Pulse Width (Note 19)	tAPD2	700			ms
PDN pin Pulse Width of Spike Noise Suppressed by Input Filter (Note 20)	tPDS	0		50	ns

Note 16. IBICK rising edge must not occur at the same time as ILRCK edge.

Note 18. TDM modes are only supported in slave mode.

Note 19. The AK4137 can be reset by bringing the PDN pin = "L".

Note 20. "L" pulse width of spike noise suppressed by input filter of the PDN pin.

Parameter	Symbol	Min.	Typ.	Max.	Unit
Control Interface Timing					
CCLK Period	tCCK	200		-	ns
CCLK Pulse Width High	tCCKH	80		-	ns
CCLK Pulse Width Low	tCCKL	80		-	ns
CDTI Setup Time	tCDS	50		-	ns
CDTI Hold Time	tCDH	50		-	ns
CSN High Time	tCSW	150		-	ns
CSN "↓" to CCLK "↑"	tCSS	50		-	ns
CCLK "↑" to CSN "↑"	tCSH	50		-	ns
CCLK "↓" to CDTO	tDCD			45	ns
CSN "↑" to CDTO "Hi-Z"	tCCZ			70	ns
Control Interface Timing (I²C Bus):					
SCL Clock Frequency	fSCL	-		400	kHz
Bus Free Time Between Transmissions	tBUF	1.3		-	μs
Start Condition Hold Time (prior to first clock pulse)	tHD:STA	0.6		-	μs
Clock Low Time	tLOW	1.3		-	μs
Clock High Time	tHIGH	0.6		-	μs
Setup Time for Repeated Start Condition	tSU:STA	0.6		-	μs
SDA Hold Time from SCL Falling (Note 21)	tHD:DAT	0		-	μs
SDA Setup Time from SCL Rising	tSU:DAT	0.1		-	μs
Rise Time of Both SDA and SCL Lines	tR	-		0.3	μs
Fall Time of Both SDA and SCL Lines	tF	-		0.3	μs
Setup Time for Stop Condition	tSU:STO	0.6		-	μs
Pulse Width of Spike Noise Suppressed by Input Filter	tSP	0		50	ns
Capacitive load on bus	Cb	-		400	pF

Note 21. Data must be held for sufficient time to bridge the 300 ns transition time of SCL.

■ Timing Diagrams

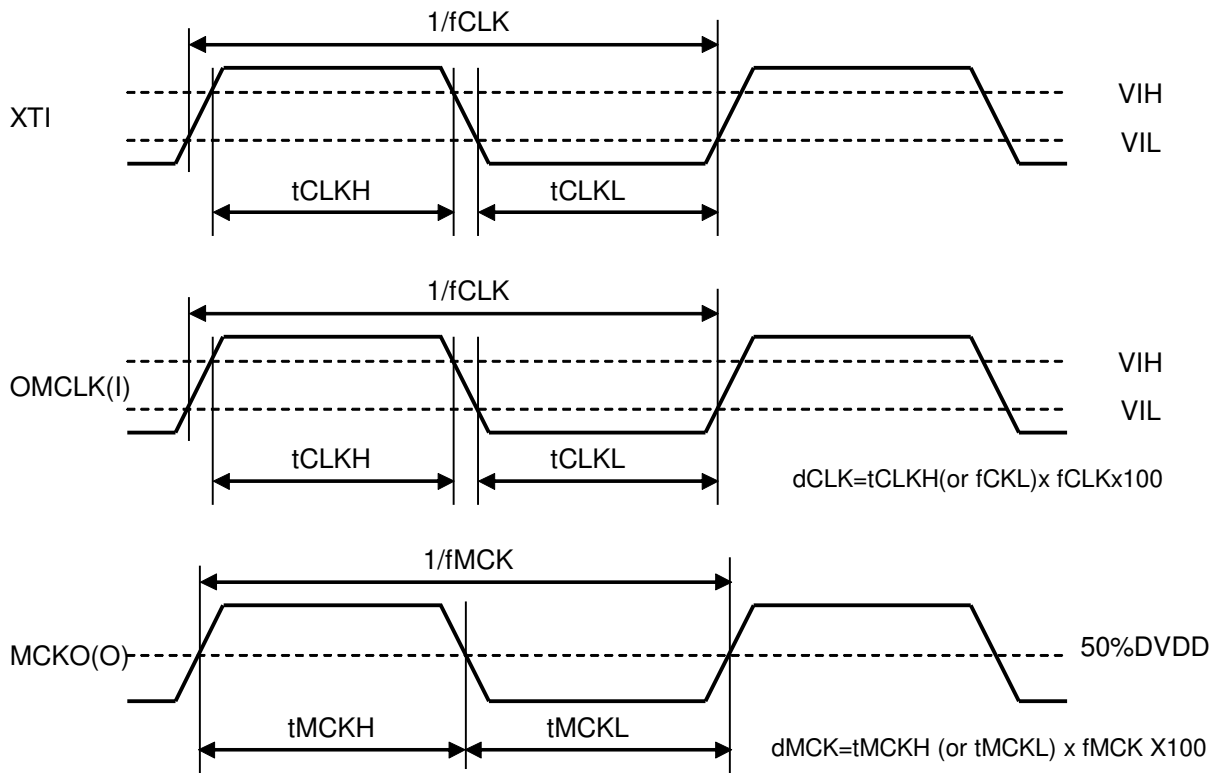
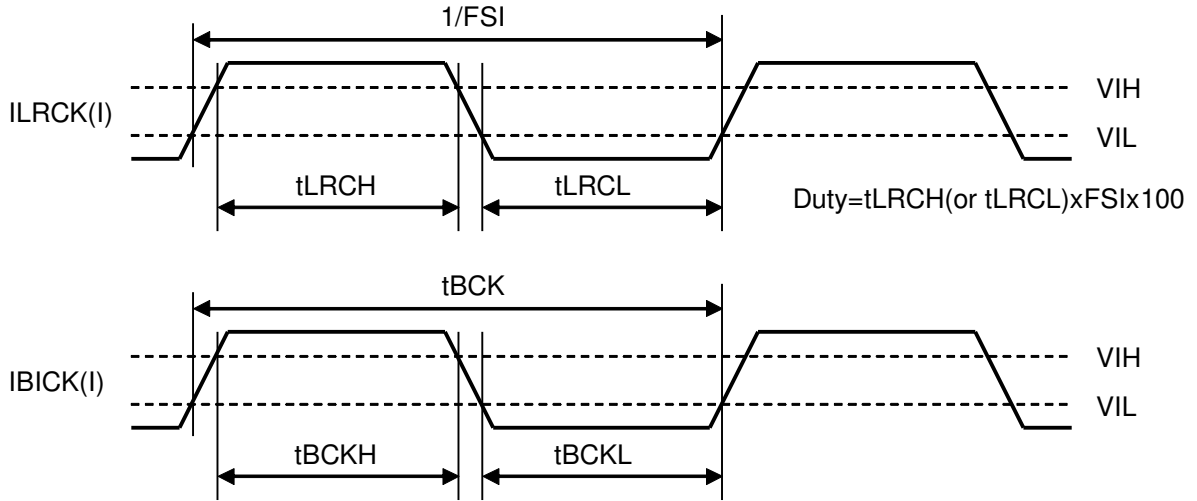

Figure 3. OMCLK, MCKO Clock Timing

Slave Mode



TDM256 or TDM512 Mode and Slave Mode

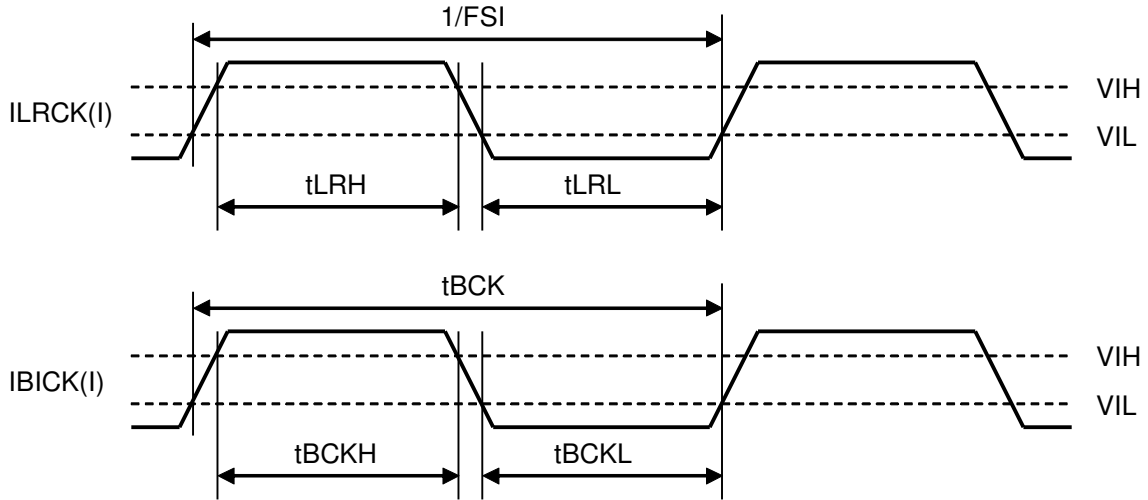
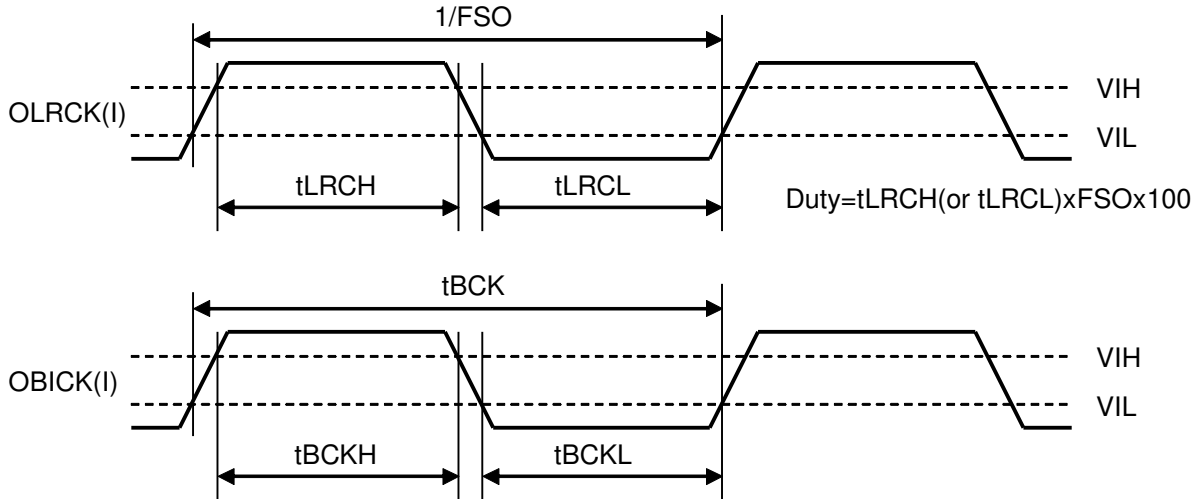

Figure 4. ILRCK, IBICK Clock Timing

Slave Mode



TDM256 or TDM512 Mode and Slave Mode

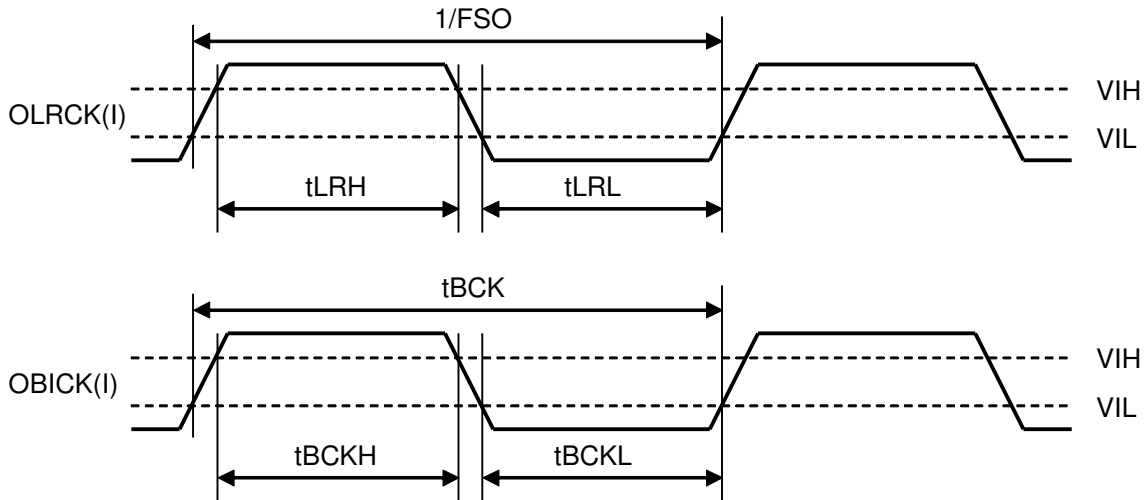

Figure 5. OLRCK, OBICK Clock Timing (Slave Mode)

Master Mode

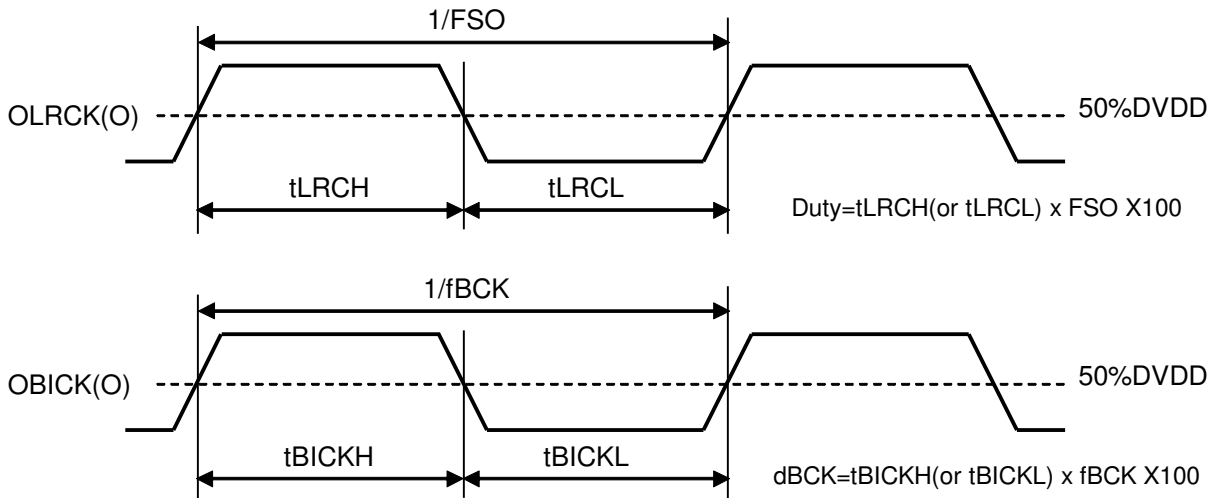

Figure 6. OLRCK, OBICK Clock Timing (Master Mode)

Slave mode and TDM256 or TDM512 Slave Mode

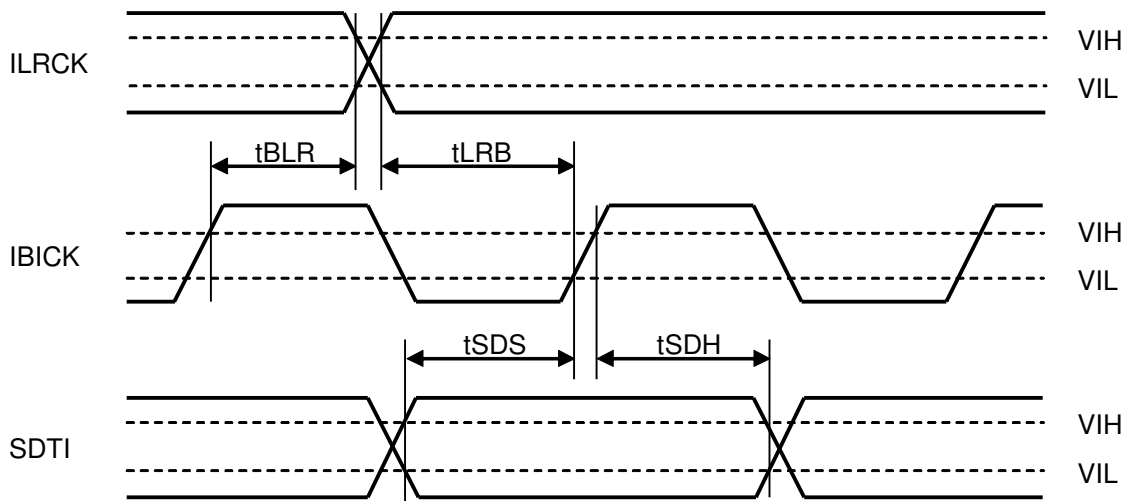

Figure 7. Input PORT Audio Interface Timing

Slave mode and TDM256 or TDM512 Slave Mode

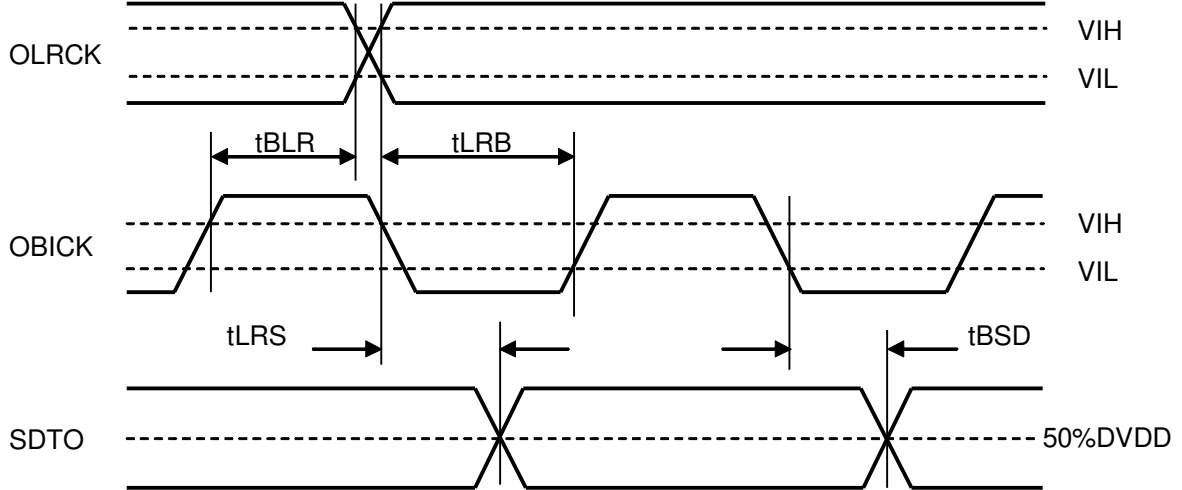

Figure 8. Output PORT Audio Interface Timing

Master mode

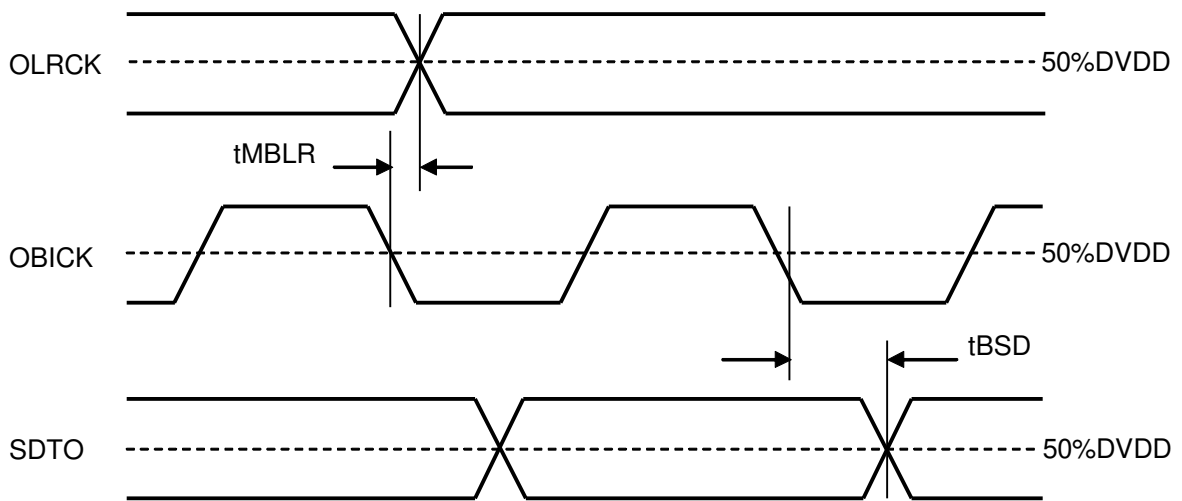

Figure 9. Output PORT Audio Interface Timing

DSD Normal Mode, DCKB bit = "0"

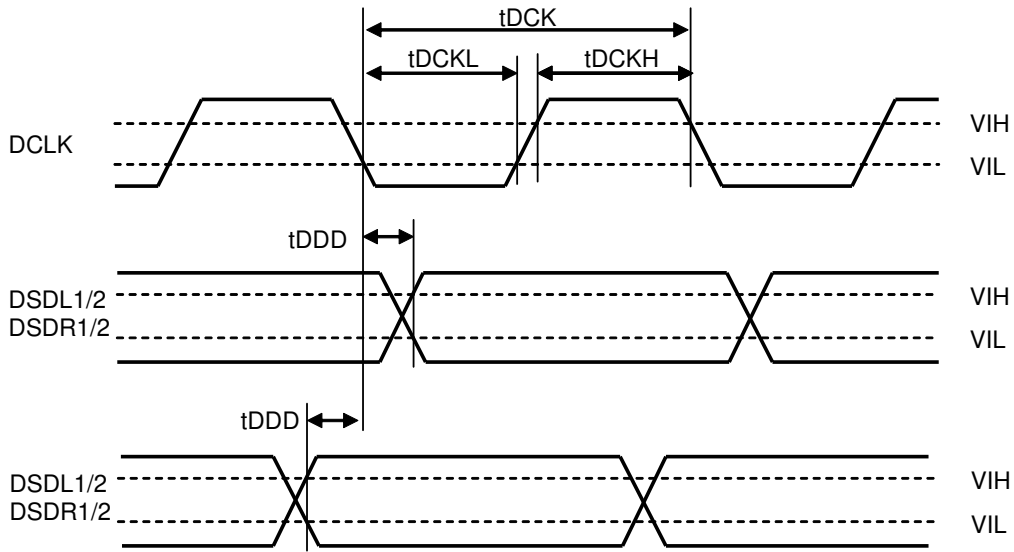

Figure 10. Audio Serial Interface Timing

DSD Phase Modulation Mode, DCKB bit = "0"

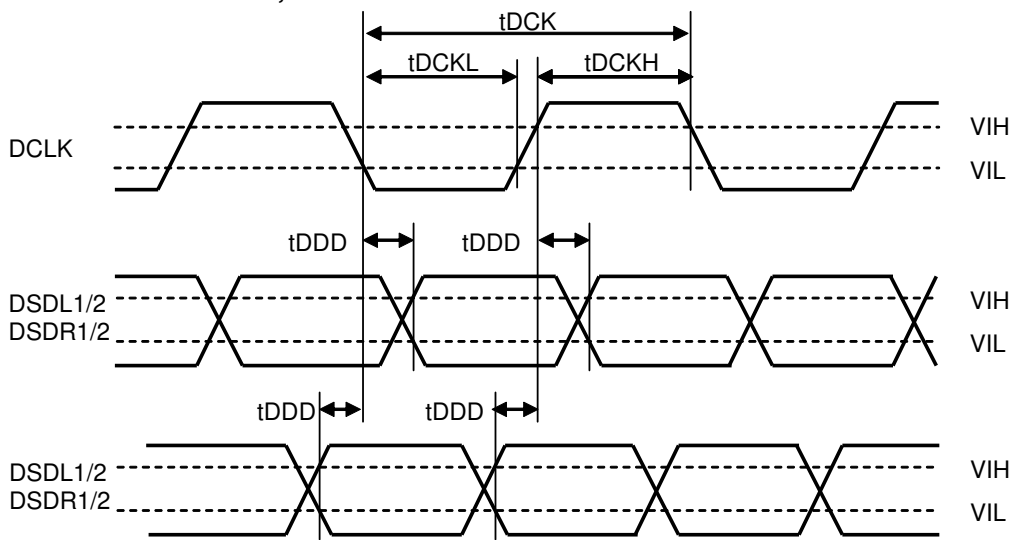

Figure 11. Audio Serial Interface Timing

4-Wire Read

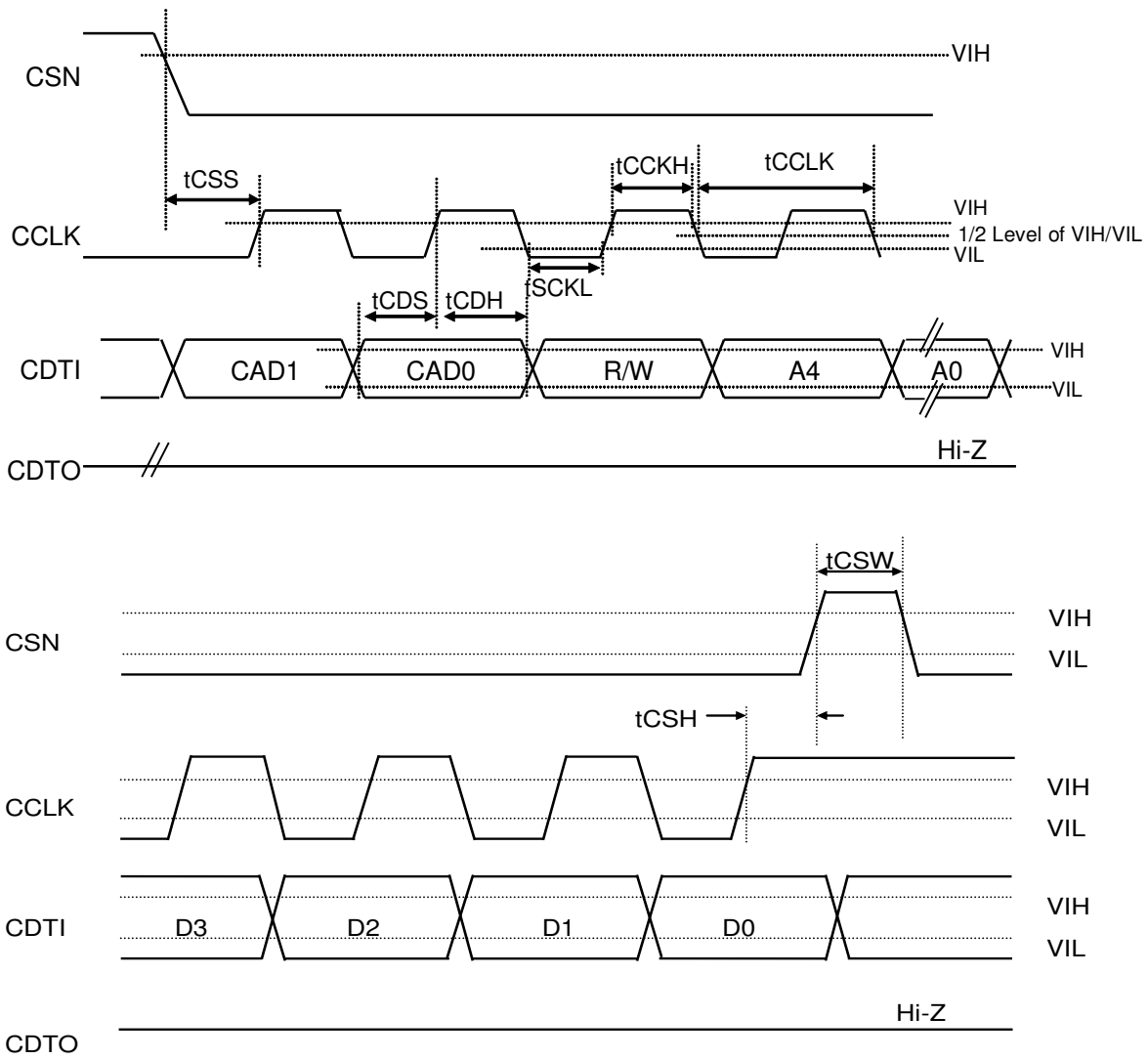

Figure 12. 4-Wire Serial Control Mode

4-Wire Write

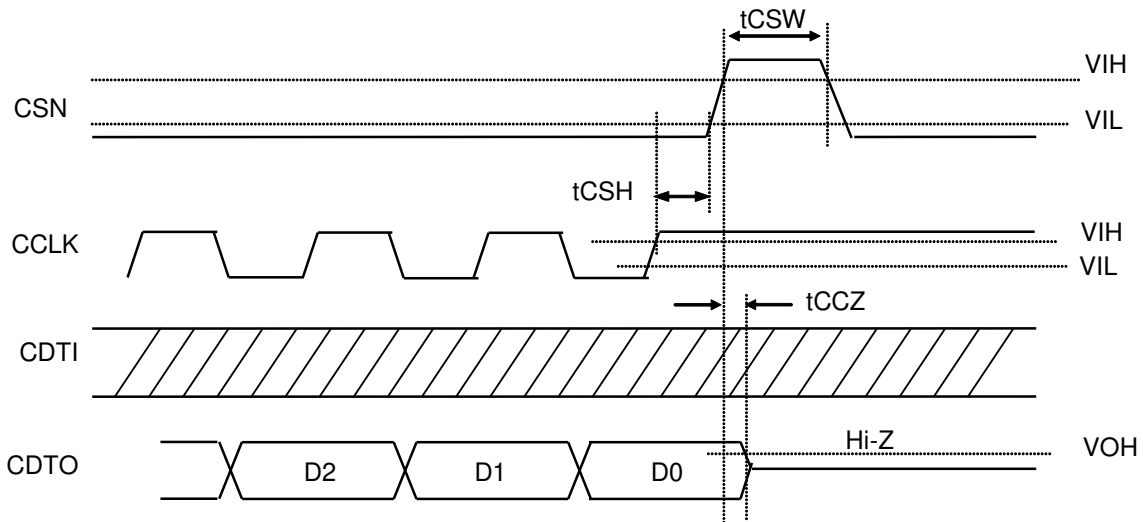
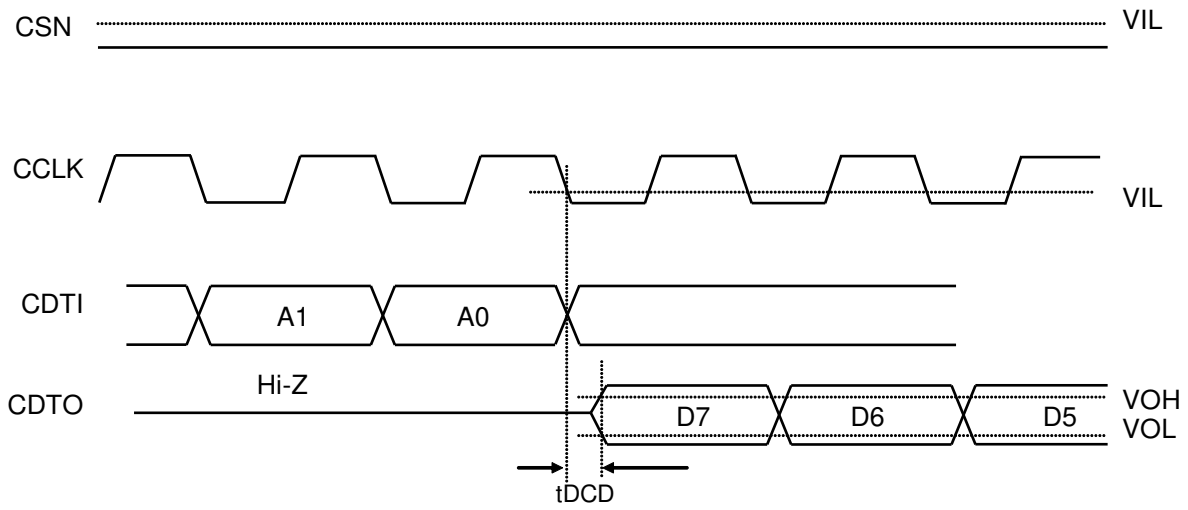

Figure 13. 4-Wire Serial Control Mode

I2C Bus Control Mode

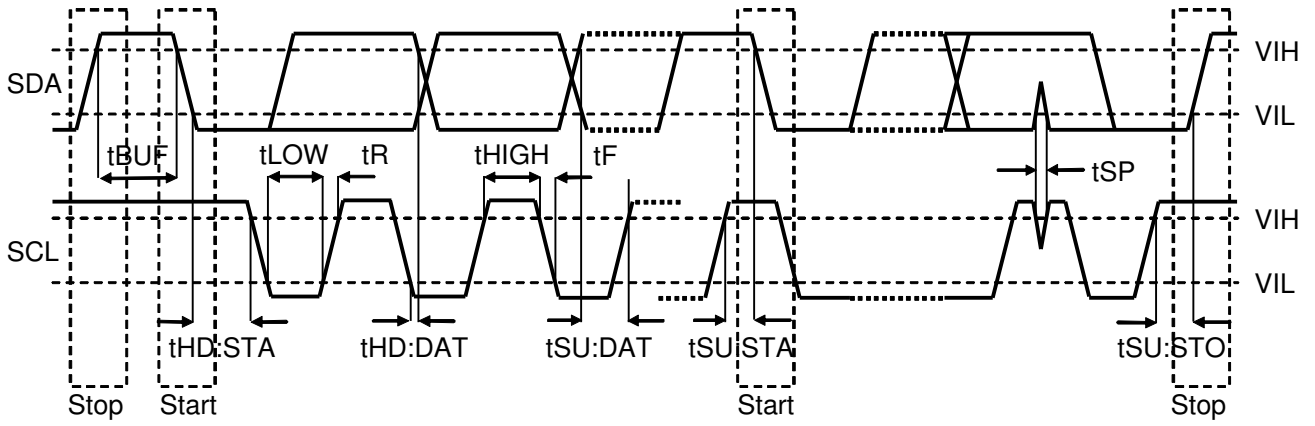

Figure 14. I²C Bus Control Mode

PDN

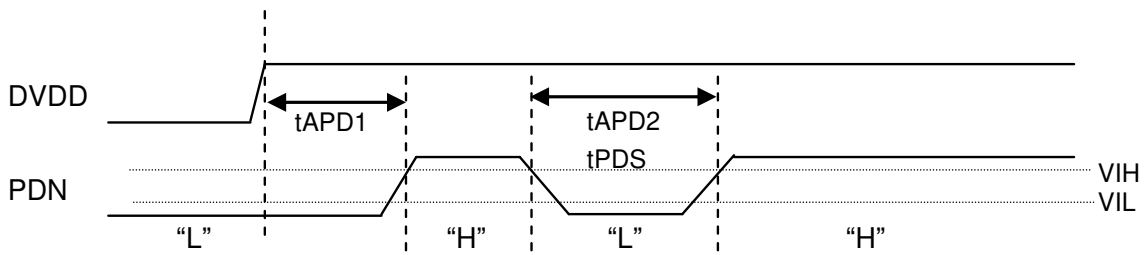

Figure 15. PDN

15. Functional Descriptions

■ **Operation Mode and Setting**

Input and Output data format of the AK4137 can be selected by DSDIE bit and DSDOE bit. DOP bit controls DoP mode and BYPS bit controls bypass mode.

BYPS	SRC mode
0	SRC
1	Bypass

Operation mode	DOP(*)	DSDIE	DSDOE	INPUT	OUTPUT
PCM->PCM	0	0	0	PCM	PCM
PCM->DSD	0	0	1	PCM	DSD
DSD->PCM	0	1	0	DSD	PCM
DSD->DSD	0	1	1	DSD	DSD
DoP->PCM	1	0	0	DoP	PCM
DoP->DSD	1	0	1	DoP	DSD
Not Available	1	1	0	-	-
Not Available	1	1	1	-	-

(*)This function is not fully DoP Specification compliant and assumes that the DoP signal is input to the AK4137 with DSD audio data format only. Do not input PCM data when DOP bit = "1". DoP Marker detection by the AK4137 accepts OR results of 0x05, 0xFA and 0xAA resulting in false triggers when PCM data is present.

■ Power-up Sequence

VSEL pin= "L" (regulator mode)

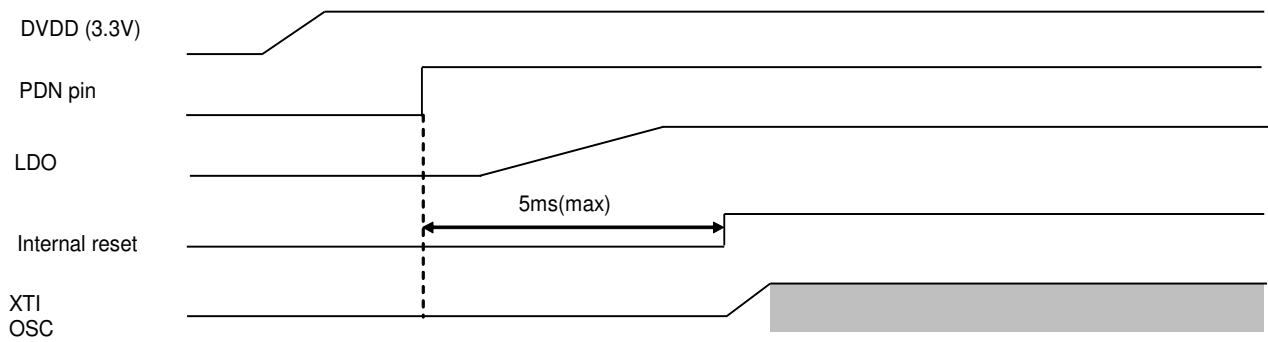

VSEL pin= "H" (regulator off mode)

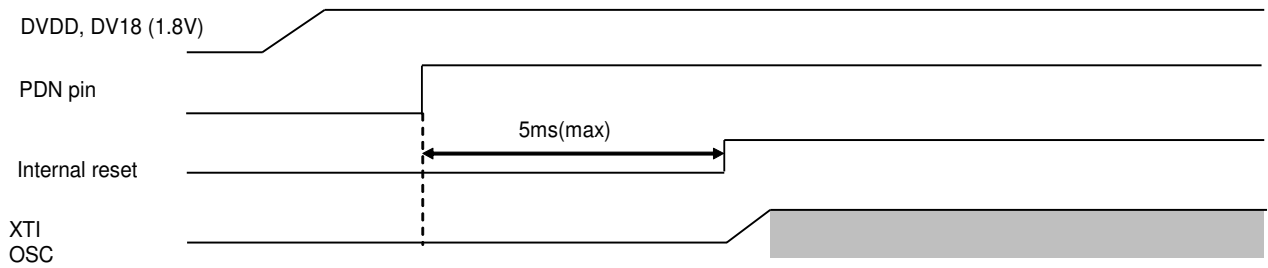

■ SRC Bypass Mode

PCMIN → PCMOUT Mode (Slave Mode)

SDTI input data is clocked in by ILRCK and IBICK according to the audio interface format shown in Table 2. SDTO output data is clocked out by OLRCK and OBICK according to the audio interface format shown in Table 5 and Table 6. OBICK must be synchronized with IBICK but the phase is not critical. OLRCK must be synchronized with ILRCK but the phase is not critical.

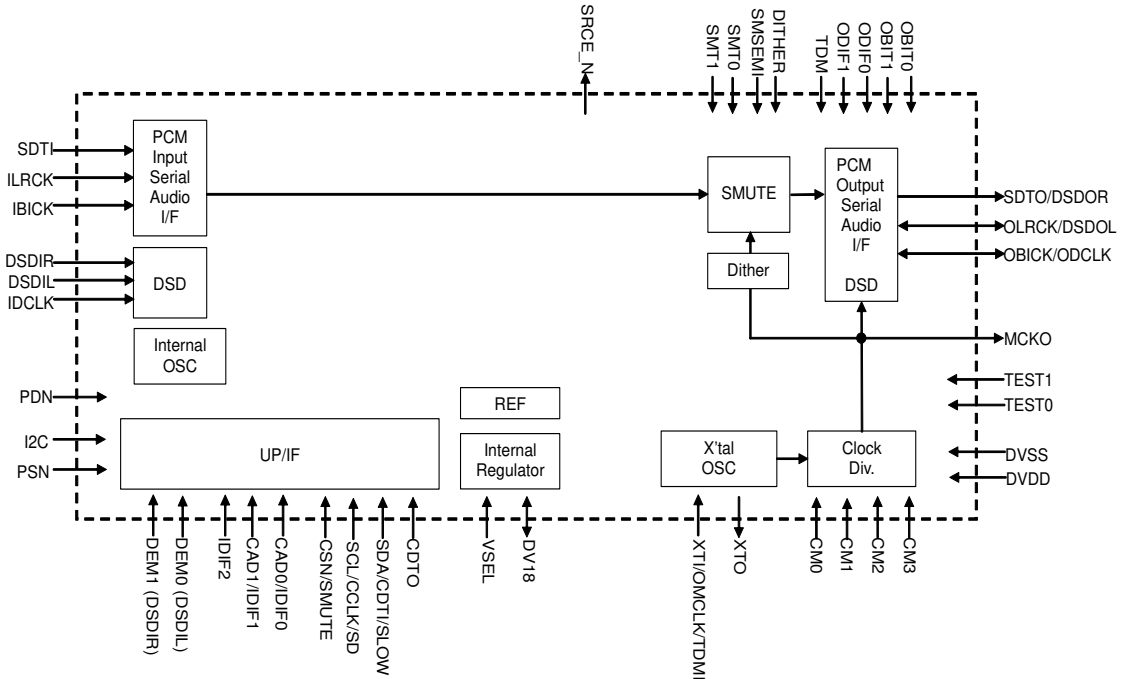

Figure 16. Bypass Mode Slave (PCMIN → PCMOUT)

PCMIN → PCMOUT Mode (Master Mode)

SDTI input data is clocked in by ILRCK and IBICK according to the audio interface format shown in Table 2. SDTO output data is clocked out by ILRCK and IBICK according to the audio interface format shown in Table 5 and Table 6. In this case, ILRCK is directly output from the OLRCK pin, and IBICK1 is directly output from the OBICK pin.

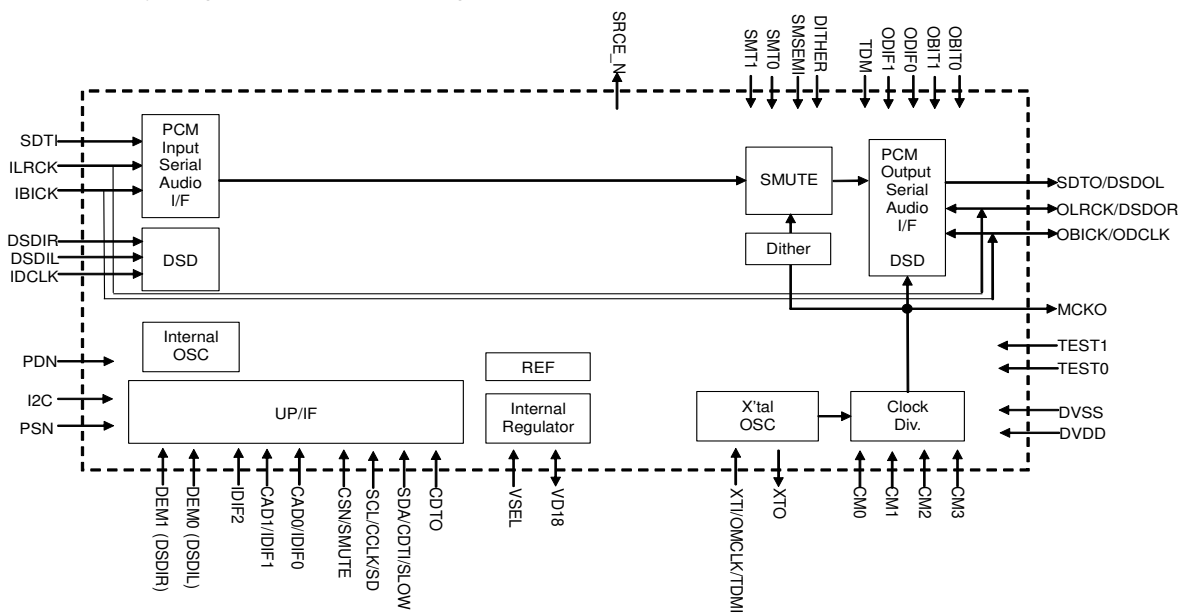

Figure 17. BYPASS Mode Master (PCMIN → PCMOUT)

DSDIN → DSDOUT Mode (Master Mode)

DSDIL and DSDIR input data are clocked in by IDCLK when DOP bit= “0”, DSDIE bit= “1” and DSDOE bit= “1”. DSDOL and DSDOR output data are clocked out by IDCLK. IDCLK is directly output from the ODCLK pin.

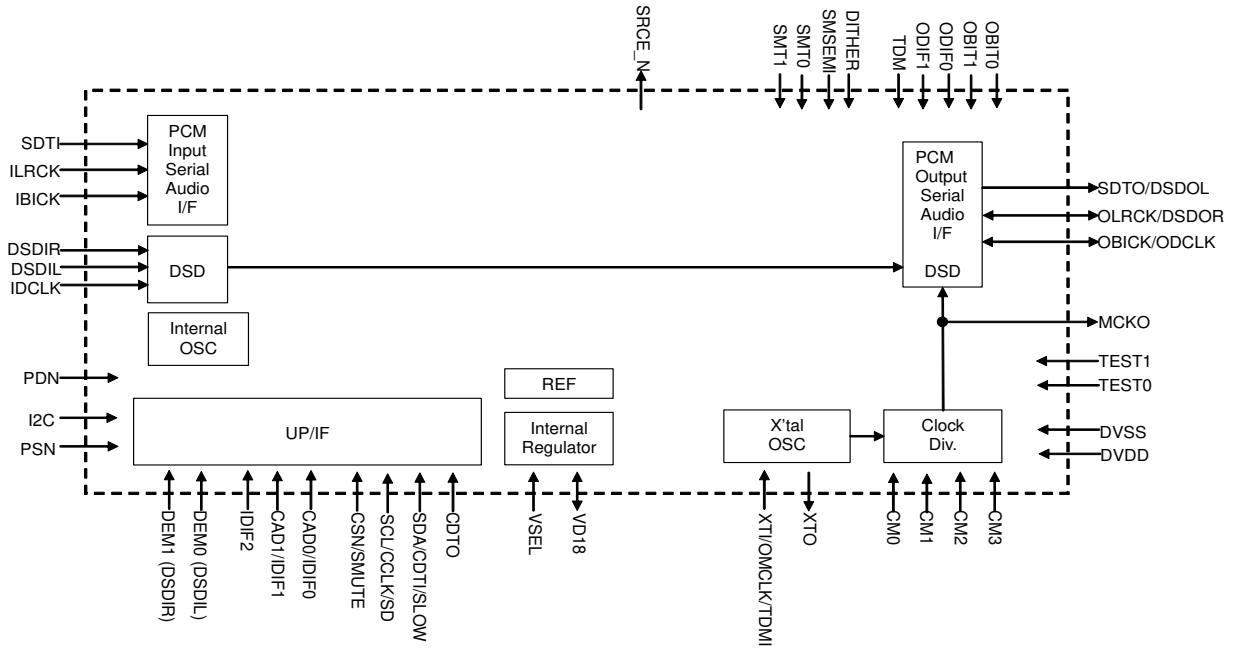

Figure 18. BYPASS Mode Master (DSDIN → DSDOUT)

PCM (DoP) → DSDOUT Mode (Master Mode)

SDTI input data is clocked in by ILRCK and IBICK according to the audio interface format shown in Table 2 (LSB is not supported) and converted to DSD data when DOP bit = “1”, DSDIE bit= “0” and DSDOE bit= “1”. DSDOL and DSDOR output data are output by ODCLK. ODCLK is generated from IBICK.

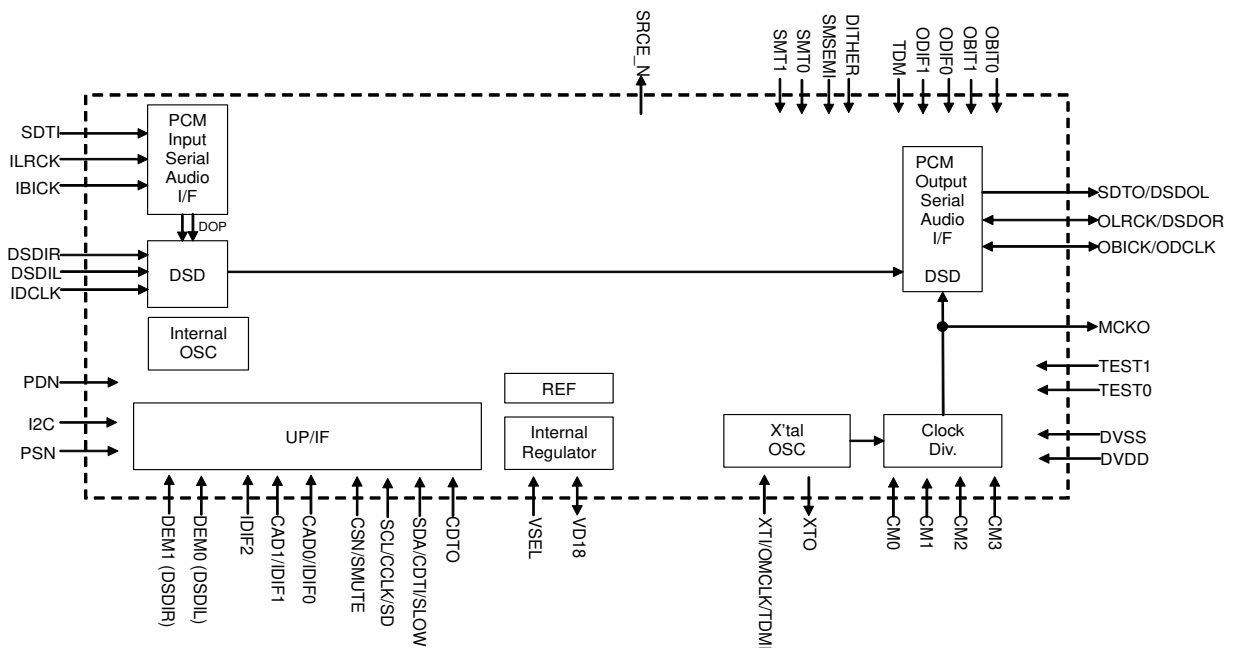

Figure 19. BYPASS Mode Master (DoP → DSDOUT)

■ **Slave Mode**

Both OLRCK and OBICK pins are input when the AK4137 is in slave mode.

■ **Master Mode**

Both OLRCK pin and OBICK pin are output when the AK4137 is in master mode. Master clock is supplied to the XTI/OMCLK/TDMI pin. The clock for the XTI/OMCLK/TDMI pin can be generated by the following methods.

1. **X'tal Mode**

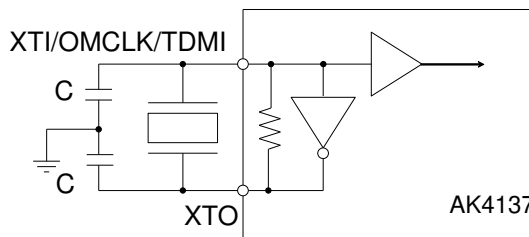

Note: Refer to Table 1 for the capacitor and resistor values of the X'tal oscillator.

Figure 20. X'tal (XTI) Mode

Normal Frequency [MHz]	11.2896	12.288	22.5792	24.576
Equivalent Series Resistance [Ω] max	60			
External Capacitor C[pF] max	15			

Table 1. Equivalent Series Resistor and External Capacitor for External X'tal Oscillator

- In X'tal mode at 256FSO mode OMCLK input, FSO ranges from 44.1kHz to 96kHz.
- In X'tal mode at 384FSO mode OMCLK input, FSO ranges from 29.4kHz to 64kHz.
- In X'tal mode at 512FSO mode OMCLK input, FSO ranges from 22.05kHz to 48kHz.
- In X'tal mode at 768FSO mode OMCLK input, FSO ranges from 14.7kHz to 32kHz.
- In X'tal mode at 128FSO mode OMCLK input, FSO ranges from 88.2kHz to 192kHz.
- In X'tal mode at 64FSO mode OMCLK input, FSO ranges from 176.4kHz to 384kHz.

2. **External Clock Mode**

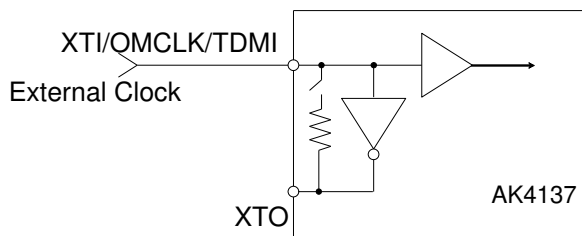

The XTO pin = "L" in External CLK mode.

Figure 21. External Clock (OMCLK) Mode

■ System Clock and Audio Interface Format for Input PORT

The audio data format of input port is MSB first, 2's complement format. The SDTI is latched on the rising edge of IBICK.

In parallel control mode (PSN pin= "H"), IDIF2-0 pins control all audio interface formats of the input port. IDIF2-0 pins must be set during the PDN pin= "L".

In serial control mode (PSN pin = "L"), the setting of IDIF2-0 pins is ignored and IDIF [2:0] bits setting is reflected. IDIF [2:0] bits should be changed after all SDTO output codes become zero during soft mute by SMUTE bit = "1" or the SMUTE pin = "H".

Mode	IDIF2 Pin/Bit (Note 23)	IDIF1 Pin/Bit (Note 23)	IDIF0 Pin/Bit (Note 23)	SDTI Format	ILRCK	IBICK	IBICK Freq
0	L	L	L	32bit, LSB justified	Input	Input	256FSI ≥ ≥64FSI
1	L	L	H	24bit, LSB justified			256FSI ≥ ≥ 48FSI
2	L	H	L	32bit, MSB justified			256FSI ≥ ≥ 64FSI
3	L	H	H	32 or 16 bit, I ² S Compatible			256FSI ≥ ≥ 64FSI
				16 bit, I ² S Compatible			
4	H	L	L	TDM 32bit, MSB justified			256FSI
5	H	L	H	TDM 32bit, I ² S Compatible			
6	H	H	L	TDM 32bit, MSB justified			
7	H	H	H	TDM 32bit, I ² S Compatible	512FSI		

Table 2. Input PORT Audio Interface Format

Note 22. When IBICK = 32FSI, the AK4137 only supports 16-bit I²S Compatible format.

Note 23. In serial control mode (PSN pin = "L"), the setting of IDIF2-0 bit is valid. In parallel control mode (PSN pin = "H"), the setting of IDIF2-0 pin is valid.

Note 24. In case parallel control mode, L1 and R1 are selected data channels in TDM input mode. In case serial control mode, the data channels are selected by TDMICH2-0 bits setting in TDM input mode.

Mode 4 and 5 (TDM256), R1 is available in below frequency range.

ILRCK: 8kHz to 18kHz, 21.8295kHz to 36kHz, 43.4385kHz to 71.5kHz, 86.436kHz to 96kHz

Mode 6 and 7 (TDM512), R1 is available in below frequency range.

ILRCK: 8kHz to 9kHz

Mode 6 and 7 (TDM512), in case TDMICH2-0bit = "001" (just Parallel Control mode), R2 is available in below frequency range.

ILRCK: 8kHz to 18kHz, 21.8295kHz to 36kHz, 43.4385kHz to 48kHz

Regarding L1, R1 and R2, please refer [Figure 26](#), [Figure 27](#), [Figure 28](#) and [Figure 29](#).

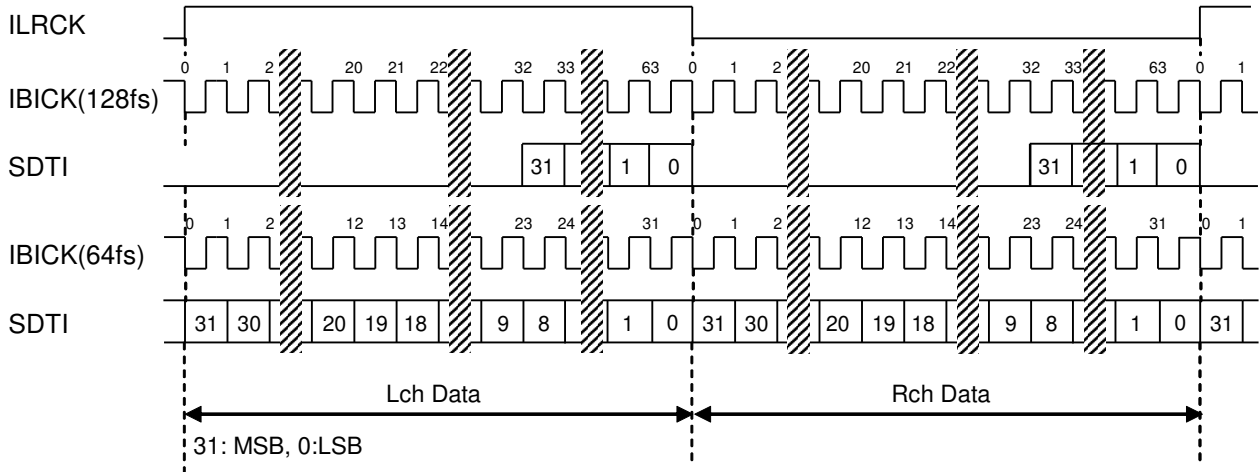

Figure 22. Mode0 Timing (32-bit LSB)

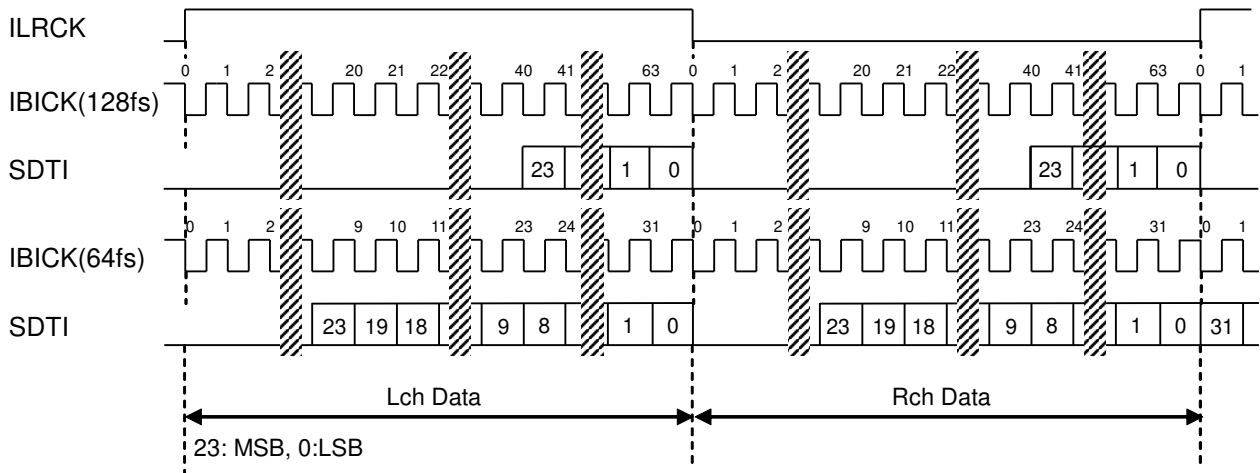

Figure 23. Mode1 Timing (24-bit LSB)

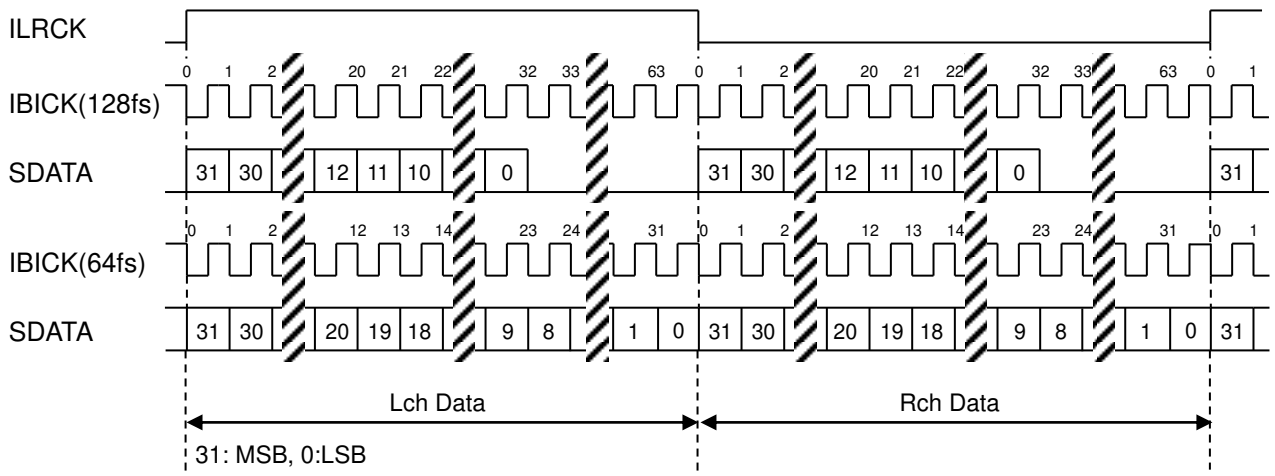

Figure 24. Mode2 Timing (32-bit MSB)

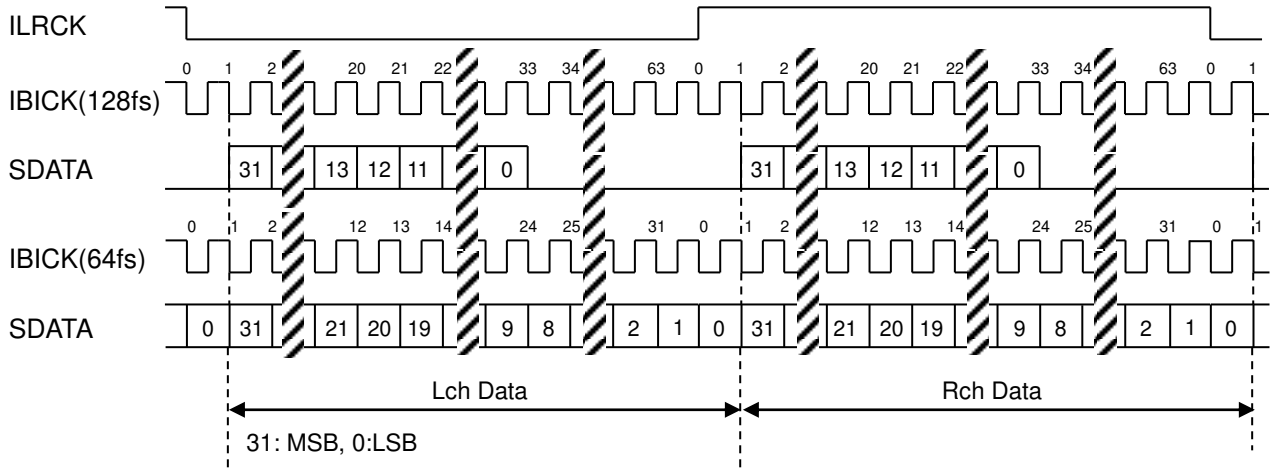

Figure 25. Mode3 Timing (32-bit I²S)

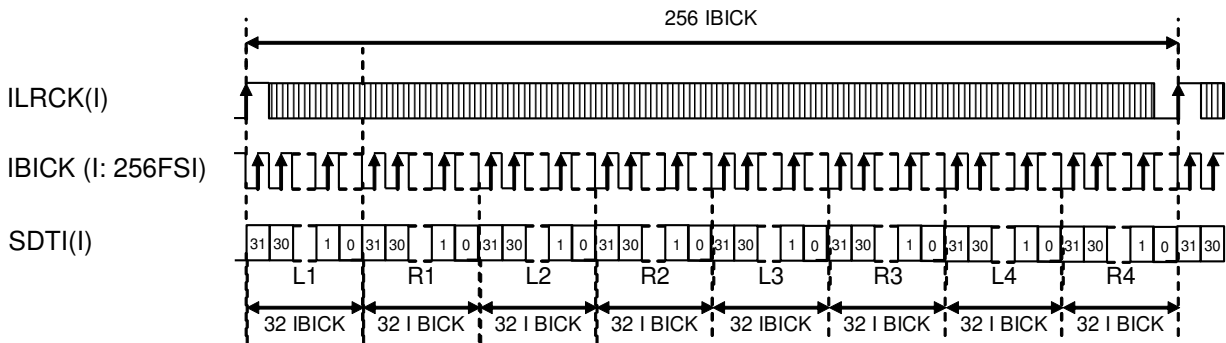

Figure 26. Mode4 Timing (32-bit MSB TDM256fs)

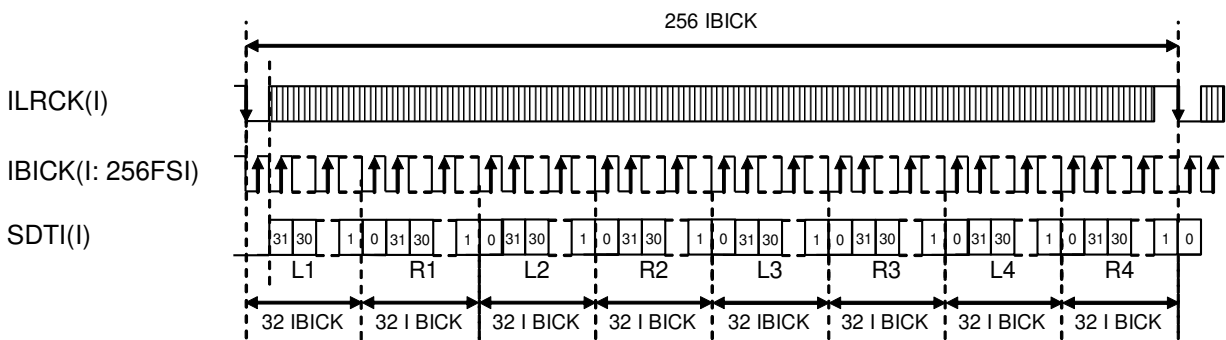

Figure 27. Mode5 Timing (32-bit I²S TDM256fs)

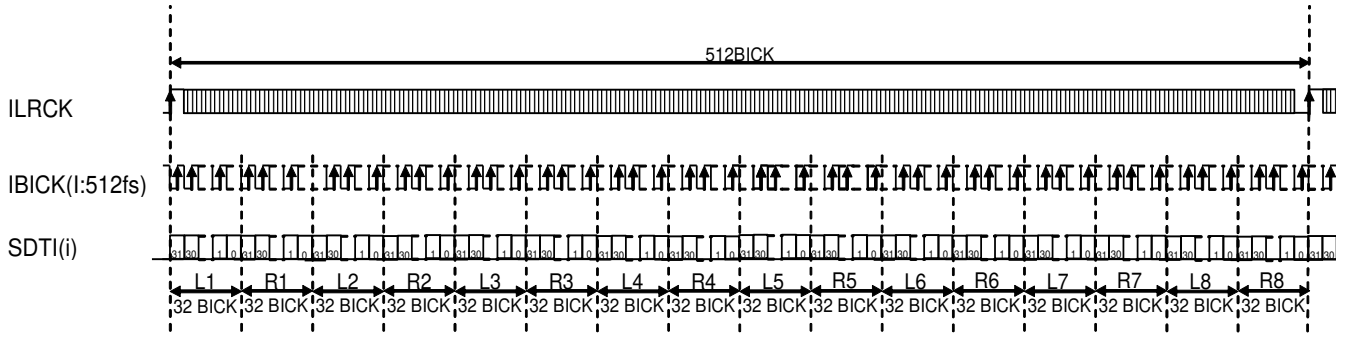

Figure 28. Mode6 Timing (32-bit MSB TDM512fs)

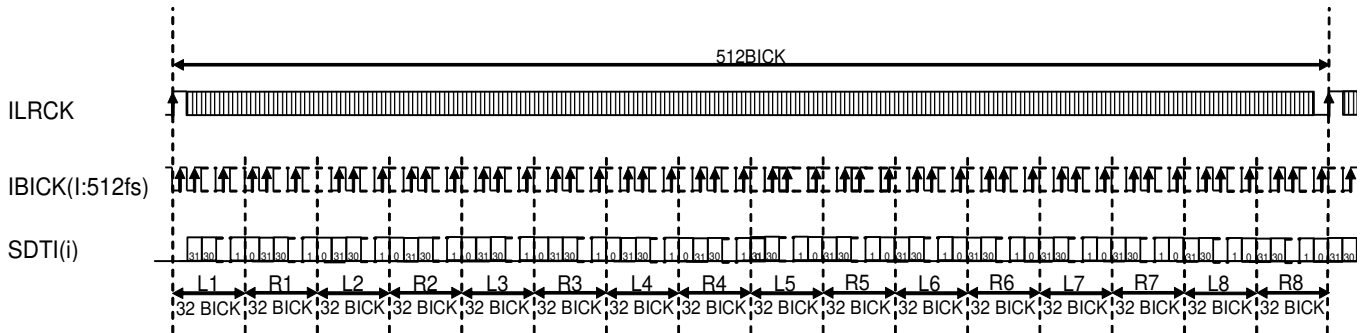

Figure 29. Mode7 Timing (32-bit I²S TDM512fs)

■ System Clock for Output PORT

The output ports work both in master and slave modes. The CM3-0 pins select the master/slave mode and SRC bypass mode.

Mode	CM3 pin	CM2 pin	CM1 pin	CM0 pin	Master / Slave	OMCLK入力 (Note 25)	MCKO 出力	FSO	
								PCM	DSD
0	L	L	L	L	Master	256FSO	256FSO	8k ~ 192kHz	-
1	L	L	L	H	Master	384FSO	384FSO	8k ~ 96kHz	-
2	L	L	H	L	Master	512FSO	512FSO	8k ~ 96kHz	-
3	L	L	H	H	Master	768FSO	768FSO	8k ~ 48kHz	-
4	L	H	L	L	Slave	Not used (Note 25)	OMCLK	8k ~ 768kHz	-
5	L	H	L	H	Master	128FSO	128FSO	8k ~ 384kHz	-
6	L	H	H	L	Slave (Bypass)	Not used (Note 25)	-	-	-
7	L	H	H	H	Master (Bypass)				
8	H	-	-	-	Master	64FSO	64FSO	8k ~ 768kHz	-

Note 25. Use for a clock input or connect to DVSS. In Mode 4, the MCKO pin outputs “L” if the OMCLK/XTI pin is connected to DVSS. When a clock is input to the OMCLK/XTI pin, the clock is input through and output from the MCKO pin. In Mode 6-7, OMCLK/XTI input is ignored internally.

Note 26. DSD data cannot be selected in parallel mode.

Table 3. Output PORT Master/Slave/ Bypass Mode Control (PSN pin = “H”)

In serial control mode (PSN pin = "L"), the BYPS bit selects SRC bypass mode and SRC mode. The default value of the BYPS bit is "0" (SRC mode).

Mode	CM3 pin	CM2 pin	CM1 pin	CM0 pin	BYPS bit	Master / Slave	OMCLK Input (Note 29)	MCKO Output	FSO	
									PCM	DSD
0	L	L	L	L	0	Master	256FSO	256FSO	8k ~ 192kHz	64fs, 128fs, 256fs
1	L	L	L	H	0	Master	384FSO (Note 28)	384FSO	8k ~ 96kHz	64fs, 128fs
2	L	L	H	L	0	Master	512FSO	512FSO	8k ~ 96kHz	64fs, 128fs, 256fs
3	L	L	H	H	0	Master	768FSO	768FSO	8k ~ 48kHz	
4	L	H	L	L	0	Slave	Not used. (Note 27)	-	8k ~ 768kHz	64fs, 128fs, 256fs
5	L	H	L	H	0	Master	128FSO (Note 28)	128FSO	8k ~ 384kHz	64fs, 128fs
6	L	H	H	L	0	Slave (Bypass)	Not used. (Note 27)	-	-	FSI
7	L	H	H	H	0	Master (Bypass)				
8	H	-	-	-	0	Master	64FSO	64FSO	8k ~ 768kHz	64fs
9	L	L	L	L	1	Master (Bypass)	Not used. (Note 27)	-	-	FSI
10	L	L	L	H	1	Master (Bypass)				
11	L	L	H	L	1	Master (Bypass)				
12	L	L	H	H	1	Master (Bypass)				
13	L	H	L	L	1	Slave (Bypass)				
14	L	H	L	H	1	Master (Bypass)				
15	L	H	H	L	1	Slave (Bypass)				
16	L	H	H	H	1	Master (Bypass)				
17	H	-	-	-	1	Master (Bypass)	-	-	FSI	

Note 27. Use for a clock input or connect to DVSS. In Mode 4, MCKO output becomes "L" if XTI/OMCLK/TDMI input is connected to DVSS. In this case, the clock input to the XTI/OMCLK/TDMI pin will be directly output from the MCKO pin. Mode 6, 7, 9-17, XTI/OMCLK/TDMI input is ignored internally. Bypass mode only supports PCM → PCM, DoP → DSD and DSD → DSD conversions. If other settings are applied, the AK4137 will output "L" data.

Note 28. $f_s = 44.1\text{kHz}$ or 48kHz in DSD mode. DSD output supports only 64fs and 128fs with 384FSO or 128FSO.

Note 29. In SRC mode, even input port clocks: ILRCK and IBICK are stopped, the AK4137 keeps outputting divided clock of the XTI/OMCLK/TDMI inputs if the device is in master mode and a clock input to the XTI/OMCLK/TDMI pin is being kept. In SRC bypass mode of master mode, ILRCK is input through and output from the OLRCK pin, and BICK is input through and output from the OBICK pin. Therefore the OLRCK output will be stopped if ILRCK clock at the input port is stopped, and the OBICK will be stopped if IBICK clock at the input port is stopped.

Table 4. Output PORT Master/Slave/ Bypass Mode Control (PSN pin = "L")

■ Audio Interface Format for Output PORT

The ODIF1-0 pins and OBIT1-0 pins select the audio interface format for the output port. The audio data is MSB first, 2's complement format. The SDTO is clocked out on a falling edge of OBICK. The SDTO is clocked out on a rising edge of OBICK when HEXAE bit = "1".

Select the audio interface format for output port while the PDN pin = "L". If the AK4137 is in slave mode at bypass mode, IBICK and OBICK must be synchronized but the phase is not critical. ILRCK and OLRCK must be synchronized but the phase is not critical. The audio interface format of SDTO is controlled by ODIF1-0 pins, OBIT1-0 pins and TDM pin.

Output ports become TDM mode when the TDM pin = "H". 6channels or 14channels serial data should be input to the XT1/OMCLK/TDMI pin. The SDTI pin outputs serial data for 8channels or 16channels. TDM mode is only available when the AK4137 is in slave mode.

Mode	TDM	ODIF1	ODIF0	SDTO Format
0	L	L	L	LSB justified
1	L	L	H	I ² S Compatible
2	L	H	L	MSB justified
3	L	H	H	I ² S Compatible
4	H	L	L	TDM256 mode 32bit MSB justified
5	H	L	H	TDM256 mode 32bit I ² S Compatible
6	H	H	L	TDM512 mode 32bit MSB justified
7	H	H	H	TDM512 mode 32bit I ² S Compatible

Table 5. Output PORT Audio Interface Format 1

Mode	TDM pin	Master / Slave setting	OBIT1 pin	OBIT0 pin	SDTO pin	OLRCK	OBICK	OBICK Frequency		
								MSB justified, I ² S	LSB justified	
0	L	Slave (CM3-0 = "LHLL"/"LHHL")	L	L	32bit	Input	Input	≥ 64FSO	64FSO	
1			L	H	24bit			≥ 48FSO		
2			H	L	20bit			≥ 40FSO		
3			H	H	16bit			≥ 32FSO		
4		Master (CM3-0 = "LHLL"/"LHHL" 以外)	L	L	32bit	Output	Output	64FSO		
5			L	H	24bit					
6			H	L	20bit					
7	H	H	H	16bit						
8	H	Slave (CM3-0 = "LHLL"/"LHHL")	*	*	TDM mode 32bit	Input	Input	256FSO 512FSO		
9										
10										
11										

Table 6. Output PORT Audio Interface Format 2

(*: The data length for 1channel is 32bit fixed in TDM mode. The OBIT1-0 pin settings are ignored. Connect these pins to DVSS.)

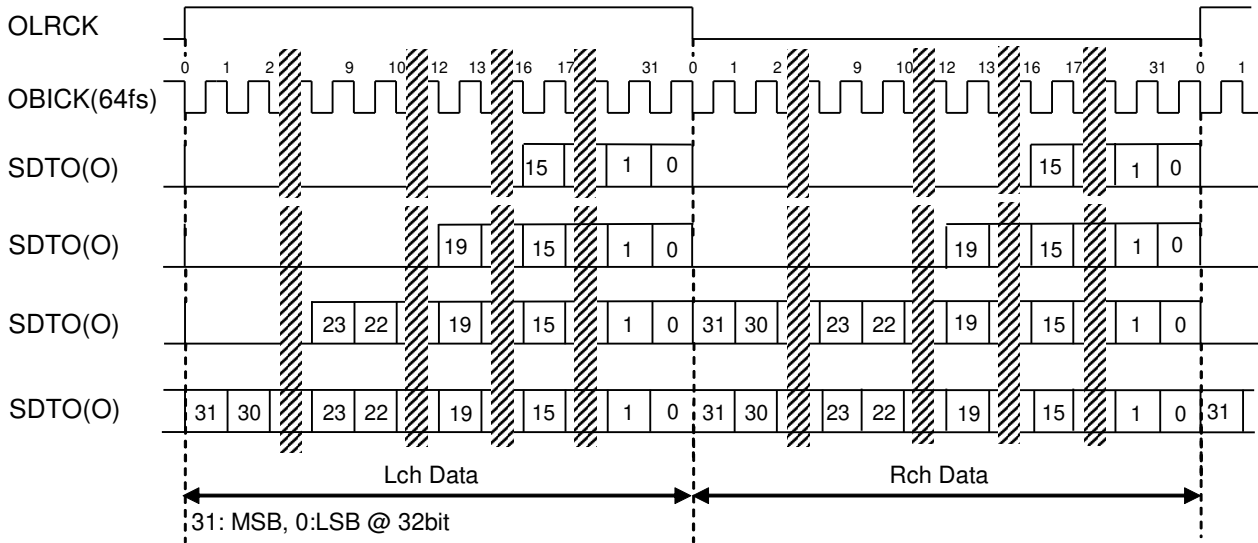

Figure 30. Stereo Mode, LSB Justified Timing

(Except when the output port is Master (Bypass) Mode and the audio interface of the input port is TDM mode (24bit MSB justified or 24bit I²S Compatible))

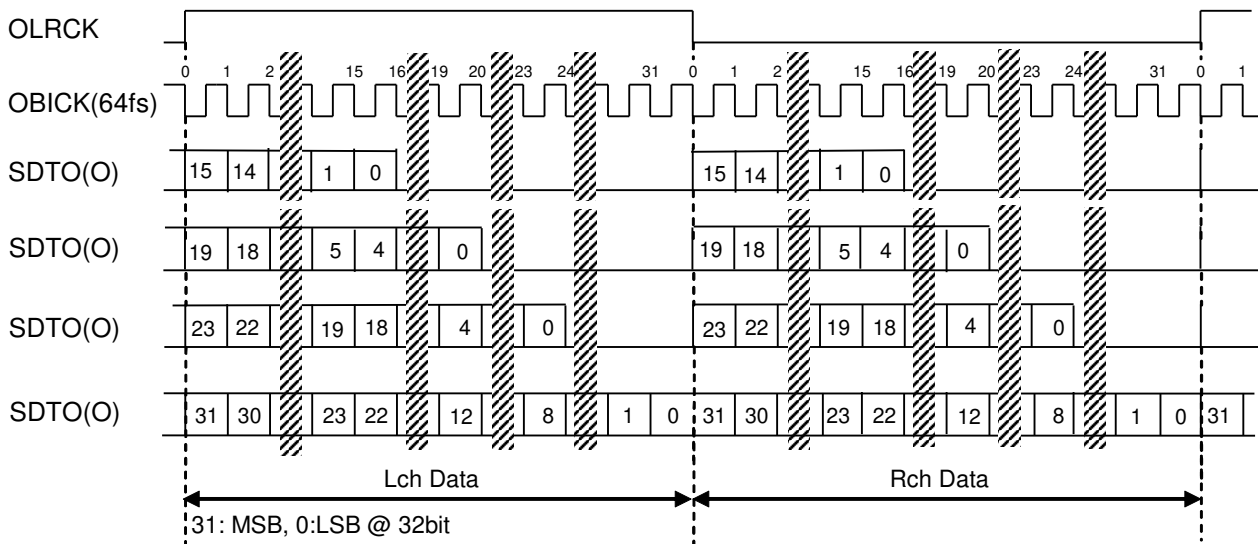

Figure 31. TDM256 mode, 32-bit MSB Justified Timing at Slave Mode

(Except when the output port is Master (Bypass) Mode and the audio interface of the input port is TDM mode (24bit MSB justified or 24bit I²S Compatible))

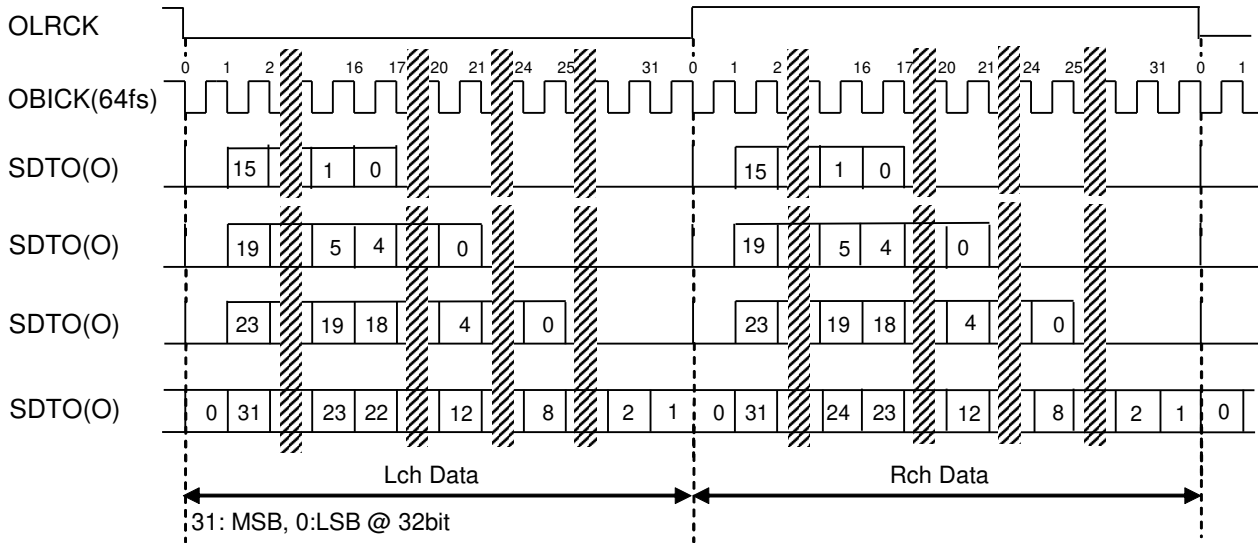

Figure 32. Stereo mode I²S Compatible Timing

(Except when the output port is Master (Bypass) Mode and the audio interface of the input port is TDM mode (32bit MSB justified or 24bit I²S Compatible))

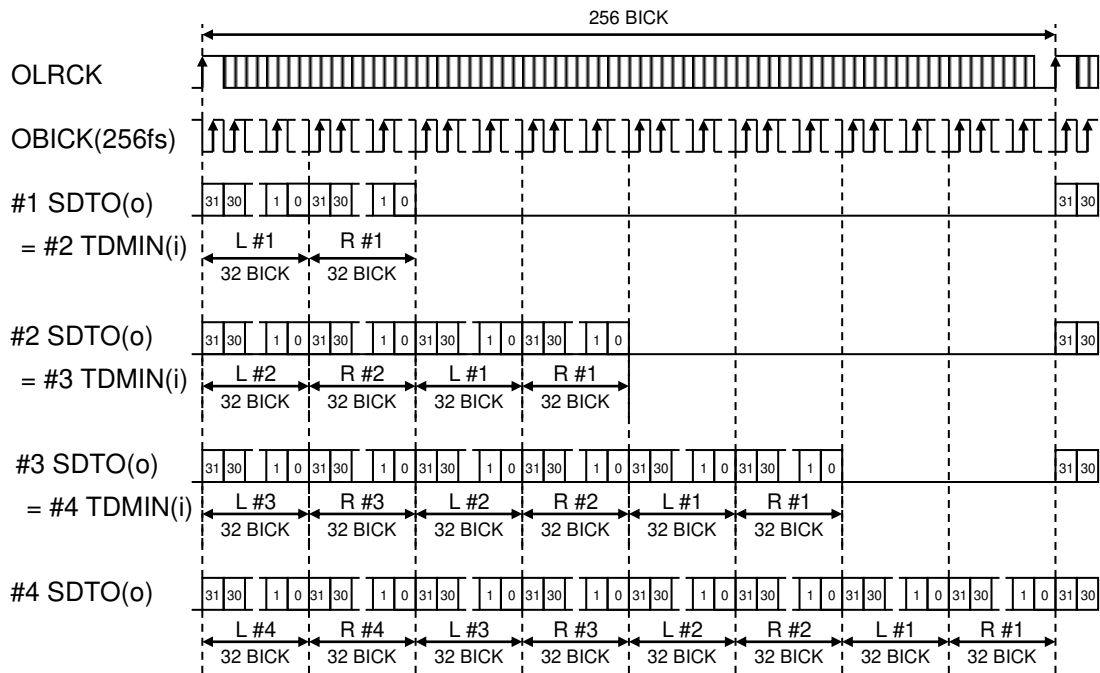

Figure 33. TDM 256 mode 32bit MSB Justified Timing at Slave Mode

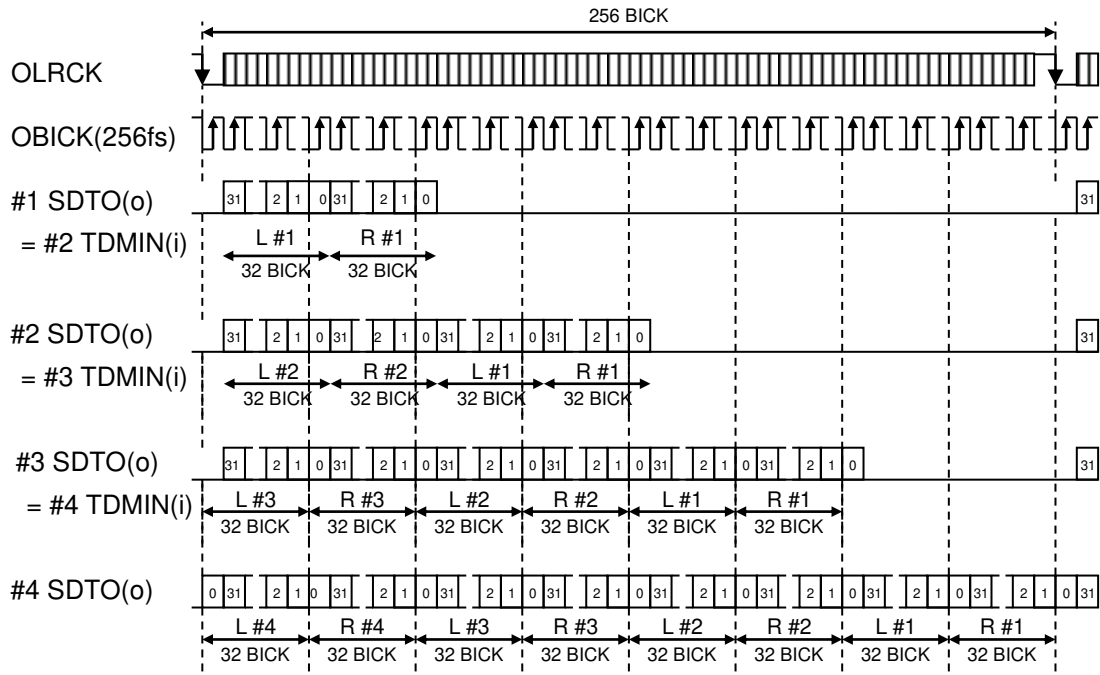

Figure 34. TDM 256 mode 32bit I²S Compatible Timing at Slave Mode

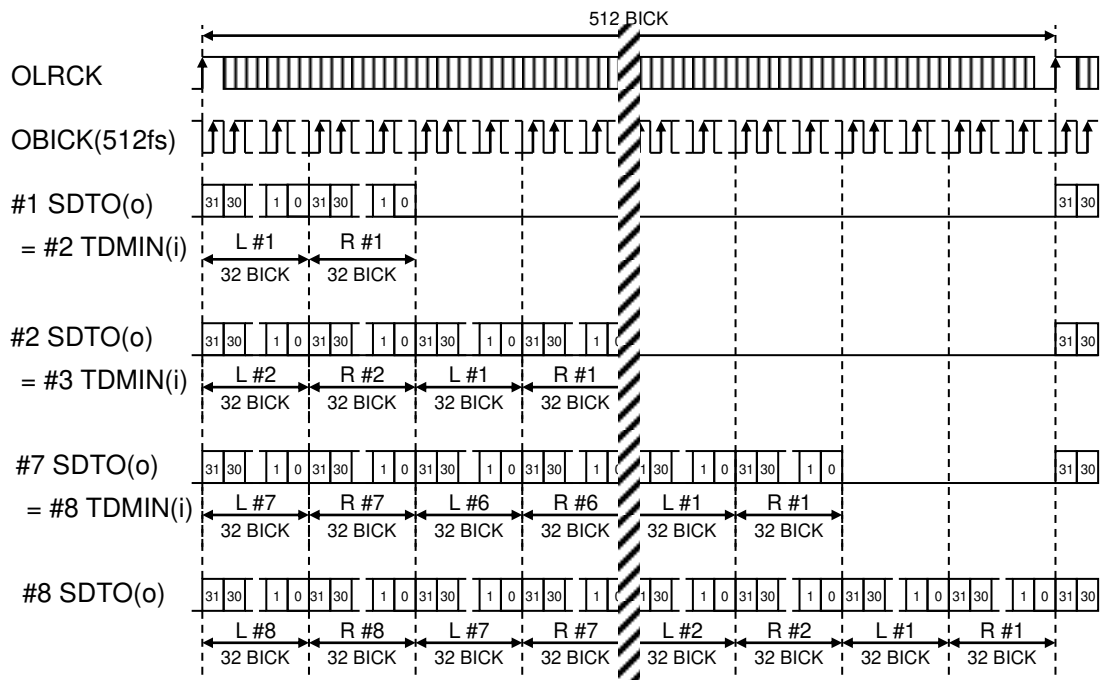

Figure 35. TDM 512 mode 32bit MSB Justified Timing at Slave Mode

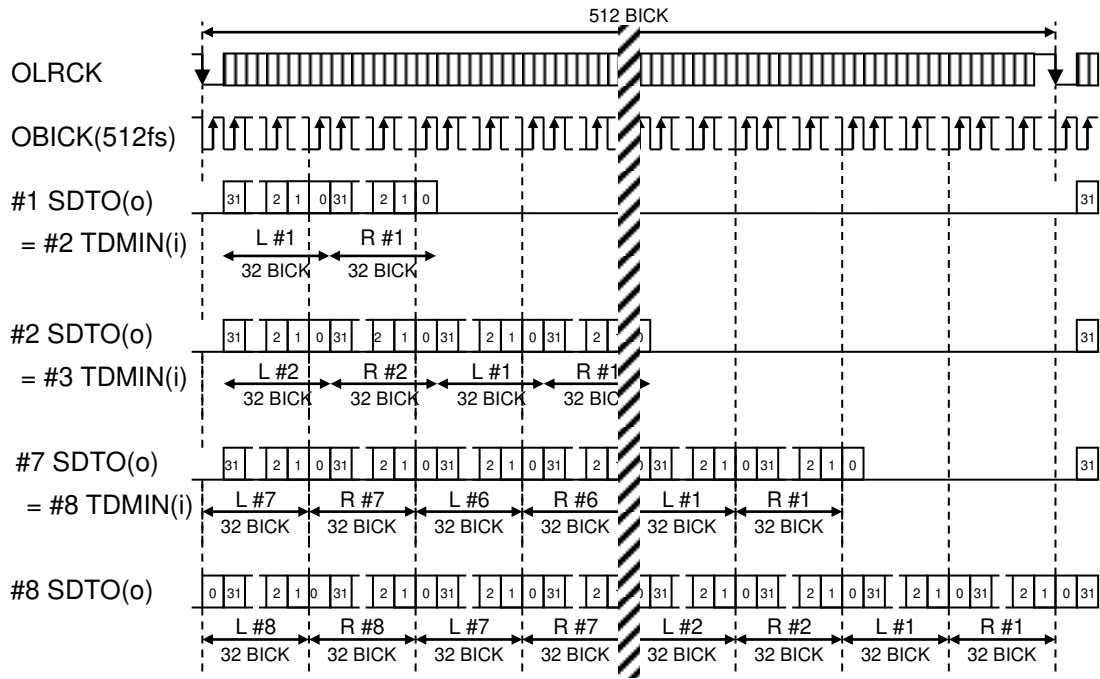

Figure 36. TDM 512 mode 32bit I²S Compatible Timing at Slave Mode

■ Cascade Connection in TDM Mode

The AK4137 supports cascading of up to four devices (8 channels data) in a daisy chain configuration in TDM mode. In this mode, SDTO pin of device #1 is connected to OMCLK (TDMIN) pin of device #2. The SDTO pin of device #2 can output 4 channels of TDM data multiplexed with 2-channel of TDM data from device #1 and 2-channel of TDM data from device #2. Figure 37 shows a connection example of a daisy chain.

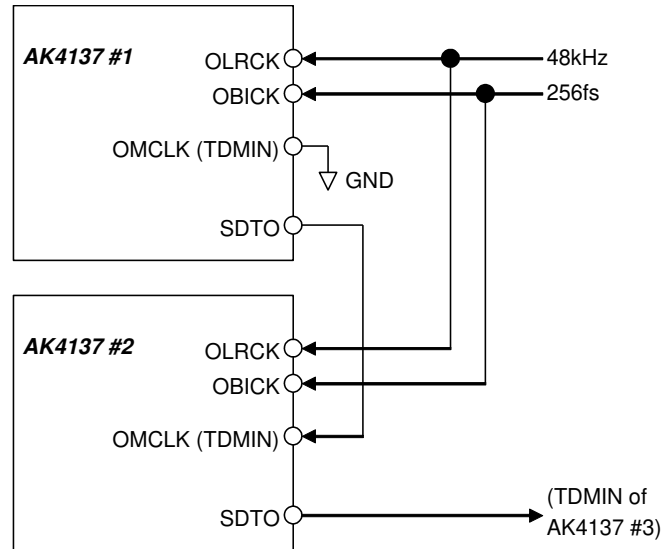

Figure 37. Cascade Connection Example

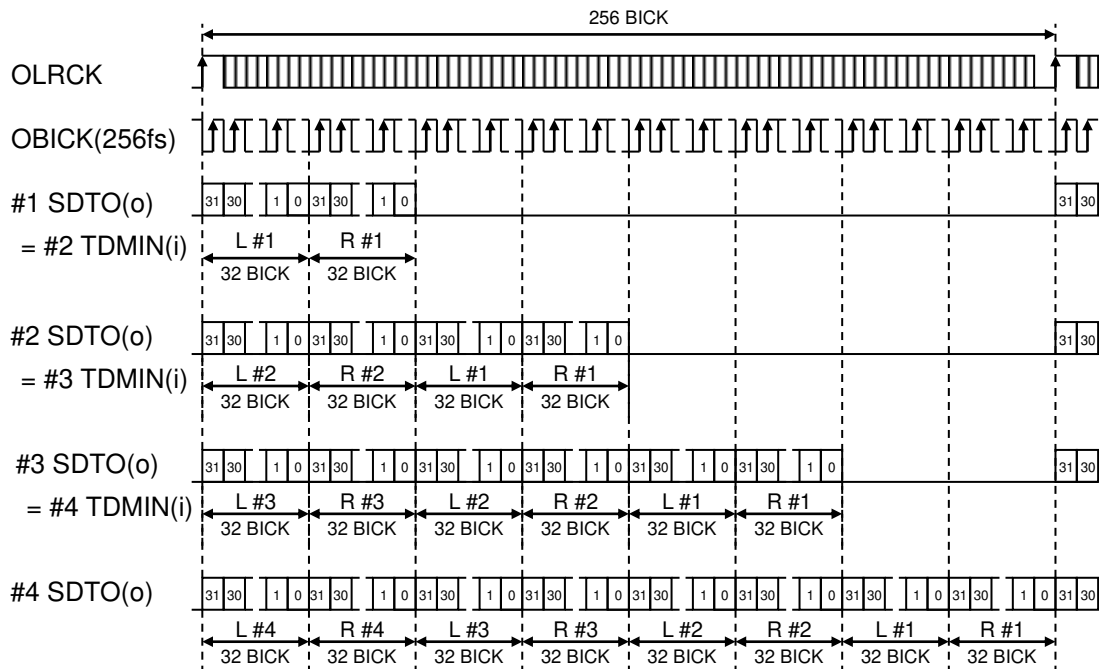

Figure 38. TDM Cascade

■ Soft Mute Function

Manual Mode

The soft mute operation is performed in the digital domain of the SRC output. SRC soft mute is controlled by the SMUTE pin in parallel control mode (PSN pin = "H") or SMUTE bit in serial control mode (PSN pin = "L"). The SRC output data is attenuated to $-\infty$ in 1024 OLRCK cycles (@ SMT1 pin = "L" and SMT0 pin = "L") by setting SMUTE pin to "H" (or SMUTE bit = "1"). When setting the SMUTE pin to "L" (or SMUTE bit to "0") the mute is cancelled and the output attenuation level gradually changes to 0dB in 1024 OLRCK cycles (@ SMT1 pin = "L" and SMT0 pin = "L"). If the soft mute is cancelled before attenuating to $-\infty$, the attenuation is discontinued and the attenuation level returns to 0dB by the same cycles. The soft mute is effective for changing the signal source without stopping the signal transmission. Soft mute cycle is set by SMT1-0 pins (PSN pin="H") (or SMT2-0 bits: PSN pin="L"). The setting of SMT1-0 pins (or SMT2-0 bits) must not be changed during soft mute transition.

SMT1 pin	SMT0 pin	Period	fso=48kHz	fso=96kHz	fso=192kHz	fso=384kHz	fso=768kHz
L	L	1024/fso	21.3ms	10.7ms	5.3ms	2.7ms	1.3ms
L	H	2048/fso	42.7ms	21.3ms	10.7ms	5.3ms	2.7ms
H	L	4096/fso	85.3ms	42.7ms	21.3ms	10.7ms	5.3ms
H	H	8192/fso	170.7ms	85.3ms	42.7ms	21.3ms	10.7ms

SMT2 bit	SMT1 bit	SMT0 bit	Period	fso=48kHz	fso=96kHz	fso=192kHz	fso=384kHz	fso=768kHz
0	0	0	1024/fso	21.3ms	10.7ms	5.3ms	2.7ms	1.3ms
0	0	1	2048/fso	42.7ms	21.3ms	10.7ms	5.3ms	2.7ms
0	1	0	4096/fso	85.3ms	42.7ms	21.3ms	10.7ms	5.3ms
0	1	1	8192/fso	170.7ms	85.3ms	42.7ms	21.3ms	10.7ms
1	0	0	16384/fso	341.3ms	170.7ms	85.3ms	42.7ms	21.3ms
1	0	1	32768/fso	682.7ms	341.1ms	170.7ms	85.3ms	42.7ms
1	1	0	reserved	-	-	-	-	-
1	1	1	reserved	-	-	-	-	-

Table 7. Soft Mute Cycle Setting (PCM)

SMT1 pin or SMT1bit	SMT0 pin or SMT0 bit	Period	64fs	128fs	256fs
L	L	1024/fso	21.3ms	21.3ms	21.3ms
L	H	2048/fso	42.7ms	42.7ms	42.7ms
H	L	4096/fso	85.3ms	85.3ms	85.3ms
H	H	8192/fso	170.7ms	170.7ms	170.7ms

*DSD Output Mode

In 256fs mode, the output gain is changed by $1/(1024 \times 256)$ fs..

In 128fs mode, the output gain is changed by $1/(1024 \times 128)$ fs.

In 64fs mode, the output gain is changed by $1/(1024 \times 64)$ fs.

SMT2 bit setting is ignored while setting registers.

Table 8. Soft Mute Cycle Setting (DSD)

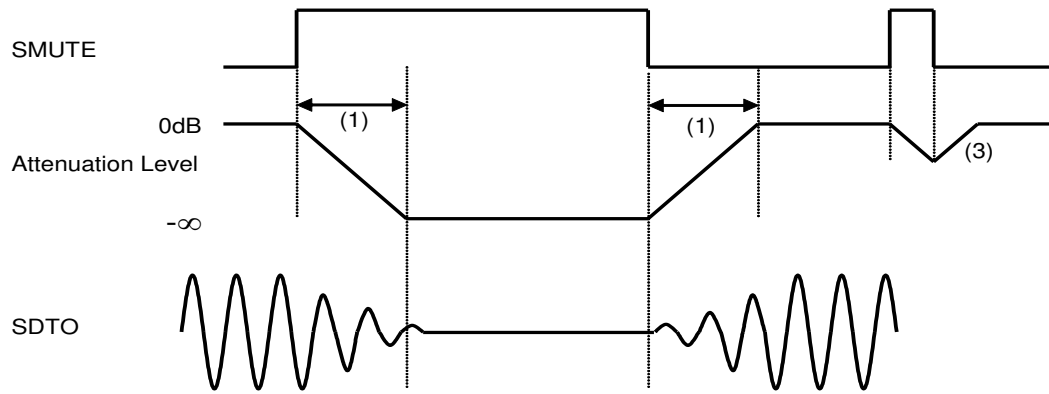

Figure 39. Soft Mute Manual Mode

- (1) Soft mute cycle is set by SMT1-0 pins or SMT2-0 bits (Table 7). The output data is attenuated to $-\infty$ in the soft mute cycle.
- (2) If the soft mute is cancelled before attenuating to $-\infty$, the attenuation is discontinued and the attenuation level returns to 0dB by the same clock cycles.
- (3) If the soft mute is cancelled within the soft mute cycle after starting soft mute operation, the attenuation is discontinued and the attenuation level returns to 0dB by the same cycle.

Semi-Auto Mode

The AK4137 enters Semi-auto Soft Mute mode by detecting power down release (PDN pin = "L" → "H") while the SMSEMI pin = "H" or reset release (RSTN bit = "0" → "1") while the PSN pin = "L".

The soft mute is cancelled automatically in $4410/\text{FSO}=100\text{ms}$ @ $\text{FSO}=44.1\text{kHz}$ after detecting a rising edge of the PDN pin = "L" → "H" (or RSTN bit = "0" → "1"). Soft mute will not be cancelled if the SMUTE pin is "H" after power-down is released (or SMUTE bit is "1" after reset is released). The setting of the SMSEMI pin must be changed during the PDN pin is "L".

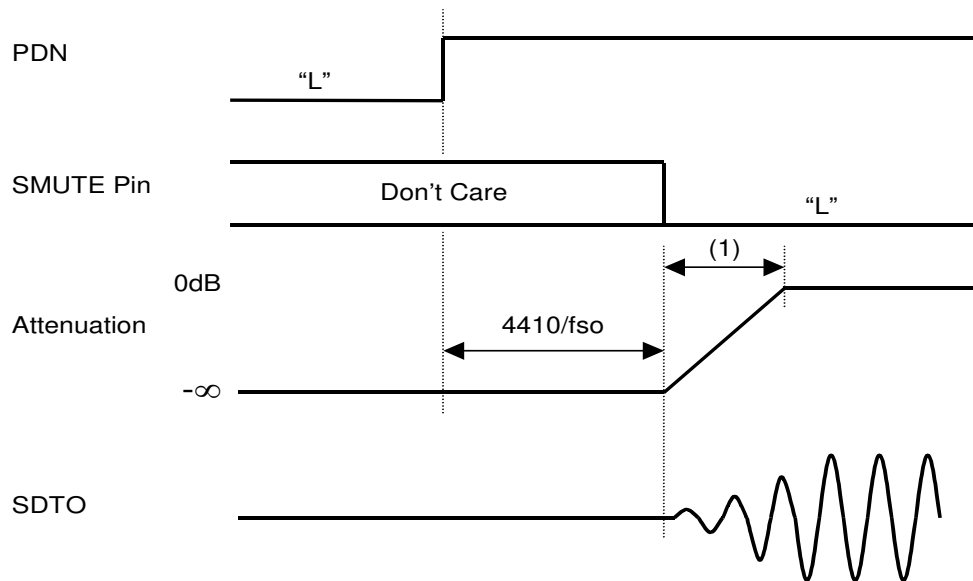

Figure 40. Soft Mute Semi-Auto Mode

- (1) The output data is attenuated by $-\infty$ during the soft mute cycle (Table 7, Table 8). (only When the SMUTE pin = "L". When the SMUTE pin = "H", the output data is kept muted.)
- (2) When the attenuation level is 0dB by a soft mute release after $4410/\text{FSO}$, the output signal is able to mute or release mute by the soft mute cycle (Table 7, Table 8).

■ Dither Circuit

The AK4137 includes a dither circuit. The dither circuit adds a dither signal after the lowest bit of all the output data set by the OBIT1-0 pins when the DITHER pin = "H", regardless of SRC and SRC bypass modes. If the output data has 32-bit length in SRC bypass mode, the output code will not be affected by the DITHER pin setting.

■ Digital Filter

The AK4137 has four kinds of digital filters and they are selected by the SD pin (#18) and the SLOW pin (#17) in parallel control mode (PSN pin = "H"). Different sound qualities on playback can be selected by these filters. In serial control mode (PSN pin = "L"), the SD pin and the SLOW pin becomes the SCL/CCLK pin and the SDA/CDTI pin, respectively and the filter setting by these pins are ignored.

SD pin	SLOW pin	Mode
L	L	Sharp roll-off filter
L	H	Slow roll-off filter
H	L	Short delay Sharp roll-off filter
H	H	Short delay Slow roll-off filter

Table 9. Digital Filter Setting (Parallel Control Mode)

SD bit	SLOW bit	Mode
0	0	Sharp Roll-off Filter
0	1	Slow Roll-off Filter
1	0	Short delay Sharp Roll-off Filter
1	1	Short delay Slow Roll-off Filter

(default)

Table 10. Digital Filter Setting (Serial Control Mode)

■ De-emphasis Filter

In parallel control mode (PSN pin = "H"), de-emphasis setting of the SRC is controlled by DEM1-0 pins. In serial control mode (PSN pin = "L"), the setting of DEM1-0 pins is ignored.

DEM1 pin	DEM0 pin	Mode
L	L	44.1kHz
L	H	OFF
H	L	48kHz
H	H	32kHz

Table 11. De-emphasis Filter Setting

■ Regulator

The AK4137 has an internal regulator which suppresses the voltage to 1.8V from DVDD. The generated 1.8V power is used as power supply for internal circuits only. When an over-current flows into the regulator output, over-current detection circuit will work. When an over-voltage flows into the regulator output, over-voltage detection circuit will work. The regulator block is powered-down and the AK4137 becomes reset state when over-current detection or over-voltage detection is executed. The AK4137 does not return to normal operation without a reset by the PDN pin when these detection circuits are worked. When over-current or over-voltage is detected, the PDN pin should be brought into "L" at once, and set to "H" again to recover normal operation.

The SRCE_N pin indicates the internal status of the device. It outputs "L" in SRC normal operation and outputs "H" when over-current or over-voltage is detected.

■ DSD Mode

DSD Input

The frequency of DCLK clock is variable between 64fs, 128fs and 256fs. The polarity of DCLK clock can be inverted.

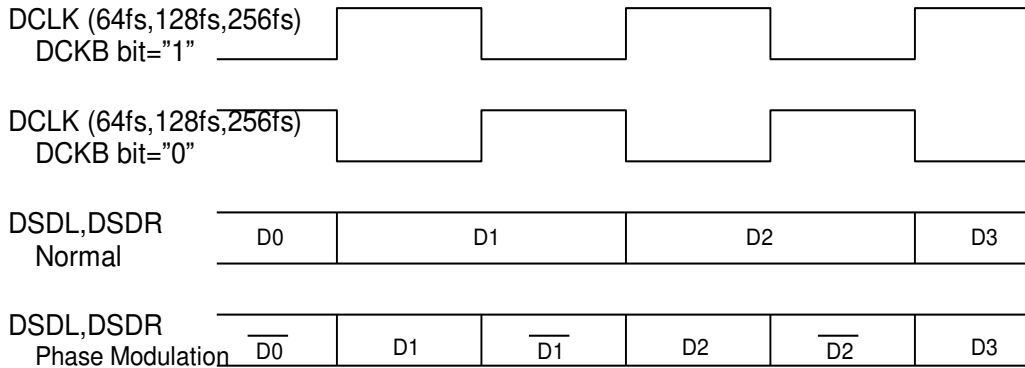

Figure 41. DSD Timing

When DSDIE bit= "1", the AK4137 enters DSD input mode. DSDIE bit must be changed while RSTN bit = "0". DSDIFS bits select IDCLK input frequency from 64fs, 128fs and 256fs. IDCLK polarity can be inverted by IDCKB bit. The input gain will be increased 6dB by setting IGAIN6 bit to "1". A cutoff filter is controlled by PCMF50 bits. Phase modulation mode is not available in 256fs mode.

DoP(*) Input

When DOP bit = "1", the AK4137 enters automatic switching mode between DoP input and PCM input modes. DOP bit must be changed while RSTN bit = "0".

PCM input mode is changed to DoP input mode automatically if DoP data detection code is input continuously for 63ILRCK cycles to SDTI when DOP bit = "1". DoP input mode is changed to PCM mode automatically if other codes are input to SDTIN continuously for 16INRCK cycles. Set DSD frequency by DSDIFS bits in DoP mode.

(*)This function is not fully DoP Specification compliant and assumes that the DoP signal is input to the AK4137 with DSD audio data format only. Do not input PCM data when DOP bit = "1". DoP Marker detection by the AK4137 accepts OR results of 0x05, 0xFA and 0xAA resulting in false triggers when PCM data is present.

DSDIFS bit	Fs	ILRCK(64fs)
"00"	64	176.4KHz/192KHz
"01"	128	352.8KHz/384KHz
"10"	256	705.6KHz/768KHz
"11"	-	Reserved

Figure 42. ILRCK Frequency and DoP Mode fs

IBICK frequency can be chosen from 48fs and 64fs. Input "0x00" to the lower 8 bits when 64fs is selected. MSB justified or I²S format can be selected by IDIF2-0 pins or bits. LSB justified format is not available.

DSD Output

The AK4137 enters DSD output mode by setting DSDOE bit = "1". DSDOE bit must be changed while RSTN bit = "0". 64fs, 128fs and 256fs ODCLK inputs are supported. The output frequency can be chosen by DSDOFS bits. The AK4137 is capable of outputting 64fs, 128fs or 256fs in Master mode. ODCLK polarity can be inverted by ODCKB bit. Input gain can be decreased 6dB by setting ODCKB bit = "1". The input gain limit is -6dB. The AK4137 cannot output correct data if the input gain exceeds this limit.

- Zero Pattern Output

If zero input is continued for a certain period, the DSD output is fixed to zero patterns.

ODCLK Frequency	Zero Input Period to Zero Patterns
64fs	1023ODCLK
128fs	1023ODCLK
256fs	1023ODCLK

In Zero pattern output, the output is fixed to "1001_0110" in 8ODCLK cycles and it is repeated until zero input is finished. The output returns to normal when zero input is finished. Zero pattern output occurs on Lch and Rch independently.

- Input Clip Function

Input signal will be clipped internally if a signal that exceeds the limit is input. Clipping process can be set by DSDCLP bits.

- Oscillation Detection Function (Error Detection)

When an oscillation is detected at the DSD output block, ERRINTL bit becomes "1" for Lch and ERRINTR bit becomes "1" for Rch. The channel that detects an oscillation will become reset state and its output pattern will be fixed to zero. Set RSTN bit to "0" to release Zero pattern fixed output. However, this error detection does not work when a full-scale (0dB) square wave is input. In this case, the output will be $-\infty$ DC (50% duty). (Error detection works if only one code is not matched when the output is clipped.) Oscillation detection function can be ON/OFF by ERRMASK bit (default: ON).

Phase modulation mode is not available when ODCLK frequency is 256fs.

■ System Reset

Bringing the PDN pin = "L" sets the AK4137 power-down mode and initializes digital filters. The AK4137 should be reset once by bringing the PDN pin = "L" upon power-up. When the PDN pin is "L", the SDTO output is "L". It takes 32ms (max) to output SDTO data after power-down state is released by a clock input. Until then, the SDTO pin outputs "L". The internal SRC circuit is powered up on an edge of ILRCK after the internal regulator is powered up.

Case 1

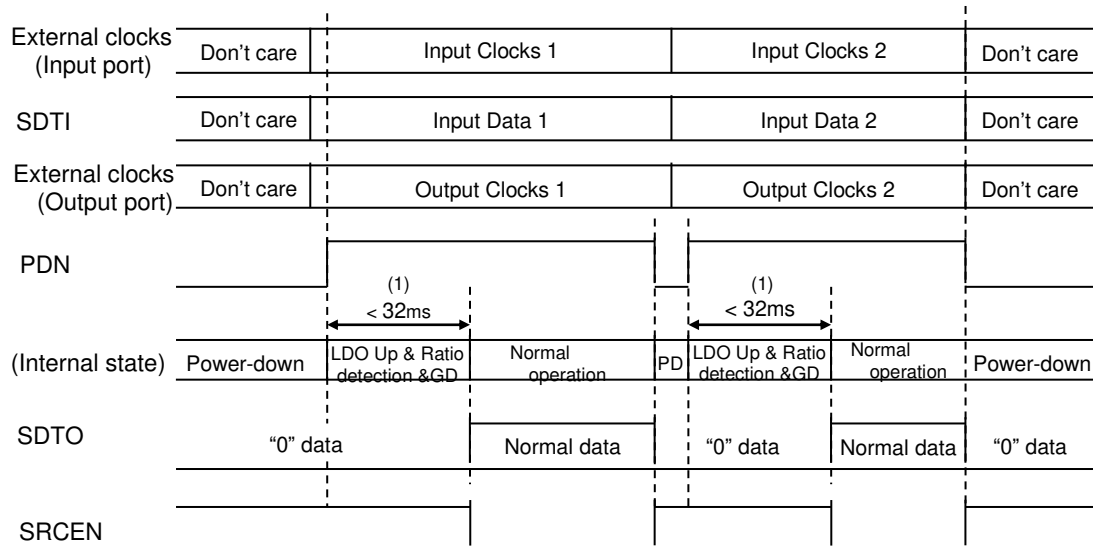

Figure 43. System Reset 1

The setting of the PSN, CM3-0, OBIT1-0, TDM, ODIF1-0, IDIF2-0, CAD1-0 pins must be changed while the PDN pin is "L". The SRCE_N pin outputs "H" during "L" period of the PDN pin. If the internal regulator is normal operation and ratio detection is completed, SRC data is output from the SDTO pin after a rising edge of the PDN pin.

Case 2

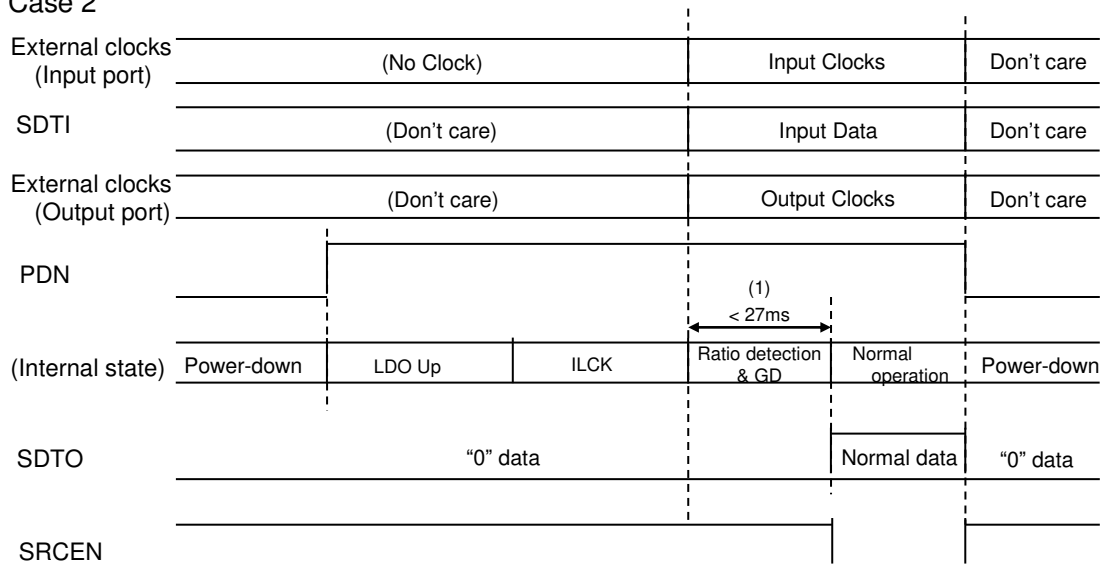

Figure 44. System Reset 2

■ Internal Reset Function for Clock Change

Clock change timing is shown in Figure 45 and Figure 46. When changing the clock, the AK4137 should be reset by the PDN pin in parallel control mode and it should be reset by the PDN pin or RSTN bit in serial control mode.

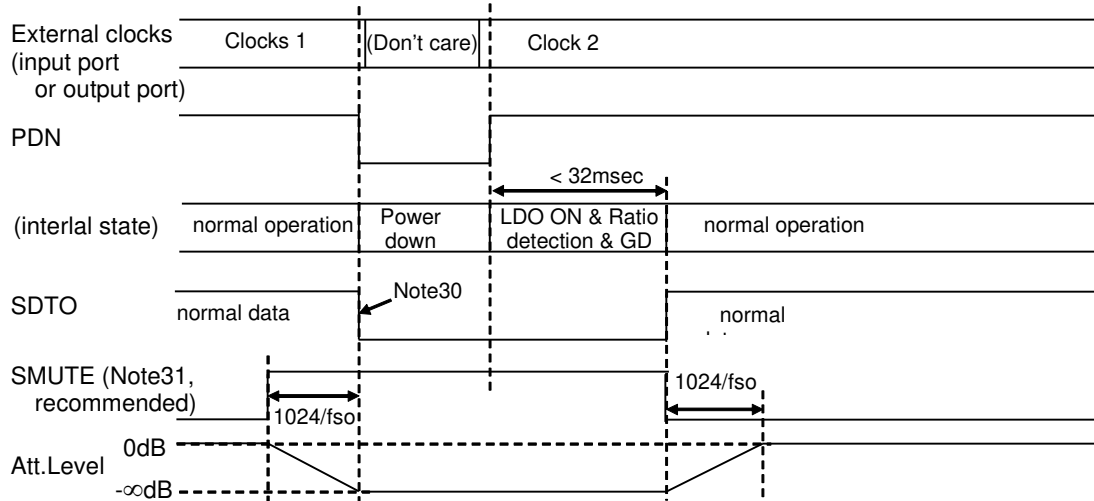

Figure 45. Sequence of Changing Clocks (Parallel Control Mode, PSN pin= "H")

Note 30. The data on SDTO may cause a clicking noise. To prevent this, set "0" to the SDTI more than 1024/fs (GD) before the PDN pin changes to "L". It makes the data on SDTO remain as "0".

Note 31. SMUTE can also remove the clicking noise (Note 30).

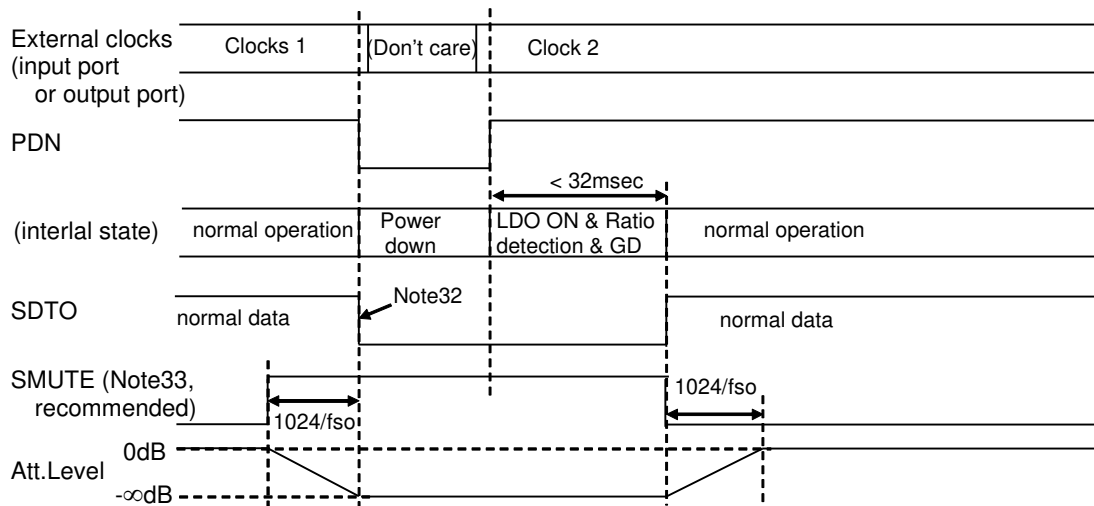

Figure 46. Sequence of Changing Clocks (Serial Control Mode, PSN pin= "L")

Note 32. The data on SDTO may cause a clicking noise. To prevent this, set "0" to the SDTI more than 1024/fs (GD) before the PDN pin changes to "L". It makes the data on SDTO remain as "0".

Note 33. SMUTE can also remove the clicking noise (Note 32).

Note 34. The digital block except serial control interface and registers is powered-down. The internal oscillator and regulator are not powered-down.

Note 35. It is the total time of "214/F_{SO}". (FSI(O) is lower frequency between FSI and FSO)

■ When the frequency of ILRCK at input port is changed without a reset by the PDN pin or RSTN bit

When the difference of internal oscillator clock number in one ILRCK cycle between before ILRCK frequency is changed (FSO/FSI ratio is stabilized) and after the change is more than 1/16 for 8cycles, an internal reset is made automatically and sampling frequency ratio detection is executed again. SDTO outputs “L” when the internal reset is made, and SRC data is output after “214/FSO” (FSI(O) is lower frequency between FSI and FSO).

If the difference of internal oscillator clock number in one ILRCK cycle between before ILRCK frequency is changed and after the change is less than 1/16 or more than 1/16 but shorter than 8cycles, the internal reset is not executed. In both cases; when ILRCK frequency is changed immediately without transition time or with transition time which is not long enough for an internal reset, it takes $5148/\text{FSO}^{**}$ (max. 643.5ms PCM Output @FSO=8kHz) to output normal SRC data. Distorted data may be output until normal SRC output.

When ILRCKx is stopped, an internal reset is executed automatically. It takes “214/FSO” [s] to output normal SRC data after ILRCKx is input again (FSI(O) is lower frequency between FSI and FSO).

■ When the frequency of OLRCK at output port is changed without a reset by the PDN pin or RSTN bit

When the difference of internal oscillator clock number in one OLRCK cycle between before OLRCK frequency is changed (FSO/FSI ratio is stabilized) and after the change is more than 1/16 for 8 cycles, an internal reset is made automatically and sampling frequency ratio detection is executed again. SDTO outputs “L” when the internal reset is made, and SRC data is output after “214/FSO” (FSI(O) is lower frequency between FSI and FSO).

If the difference of internal oscillator clock number in one OLRCK cycle between before an OLRCK frequency change and after the change is less than 1/16 or more than 1/16 but shorter than 8 cycles, the internal reset is not executed. It takes $5148/\text{FSO}^{**}$ (max. 643.5ms PCM output @FSO=8kHz) to output normal SRC data. Distorted data may be output until normal SRC output.

When OLRCK is stopped, an internal reset is executed automatically. It takes “214/FSO” [s] to output normal SRC data after ILRCKx is input again (FSI(O) is lower frequency between FSI and FSO).

** : When FSO=8kHz and FSO/FSI ratio is changed from 1/6 to 1/5.99. It is 160.9ms when FSO=32kHz and FSO/fSI ratio is changed from 1/6 to 1/5.99.

■ Pop Noise Reduction in Sampling Rate Conversion

When ILRCK and OLRCK frequencies of the input port are changed without a reset by the PDN pin or RSTN bit, the output signal is soft muted automatically if internal reset is executed by ASCHON bit = “1”. Soft mute time is the setting value shown in [Table 7](#).

■ Input Source Switching (PCM↔DSDI, DoP Mode)

Internal reset will be applied when the input source is changed from PCM to DSD or from DSD to PCM without a reset by the PDN pin or RSTN bit.

The output signal is soft muted automatically if a clock change is executed while ASCHON bit = "1". Soft mute time is the setting value shown in Table 8. Automatic soft mute is not executed even ASCHON bit = "1" if there is no clock switching.

■ Internal Status Pin

The SRCEN pin indicates internal status of the device. This pin outputs "H" when the PDN pin = "L". SRC data is output from the SDTO pin, which corresponds to the each sampling frequency ratio detected SRC, after a rising edge "↑" of PDN if the internal regulator is in normal operation.

When an over-current/voltage flows into the internal regulator, the SRCEN pin outputs "H". An OR'ed result of the flags between over-current/voltage detection at the internal regulator and SRC sampling frequency detection complete is output from this pin.

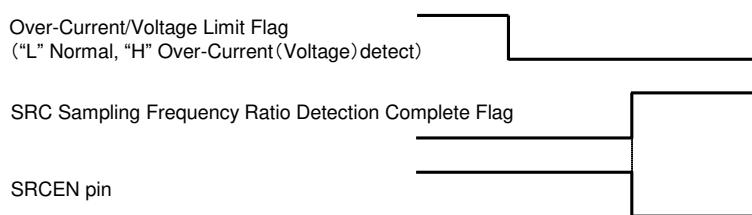

Figure 47. Internal Flags and SRCEN pin Output

In parallel control mode, if the AK4137 is set in SRC bypass mode by CM3-0 pins during the PDN pin = "L" and powered-up, the SRCEN pin outputs "L" after the power-up time of the internal regulator (max. 5ms) from a rising edge "↑" of the PDN pin.

In serial control mode, if BYPS bit is set to "1" while RSTN bit = "0", the SRCEN pin immediately outputs "L" after register writing.

■ Serial Control Interface

The AK4137 becomes serial control mode by setting the PSN pin to “L”. The AK4137 supports 4-wire serial Interface (I2S pin = “L”) and I2C bus (I2S pin = “H”) modes for internal register accessing.

4-wire Serial Control Mode (I2C pin = “L”)

The internal registers may be written by the 4-wire μP interface pins: CSN, CCLK and CDTI. The data on this interface consists of Chip address (2bits, C1/0), Read/Write (Write= “1”, Read= “0”), Register address (MSB first, 5bits) and Control data (MSB first, 8bits). Address and data are clocked in on the rising edge of CCLK and data is clocked out on the falling edge. Data write becomes available by a rising edge of CSN pin. For read operations, the CDTO output goes high impedance after a low-to-high transition of CSN. The maximum speed of CCLK is 5MHz. Internal register values are initialized by setting the PDN pin to “L”. The internal register timing circuit is reset by setting RSTN bit to “0” in serial control mode. In this case, the register values are not initialized.

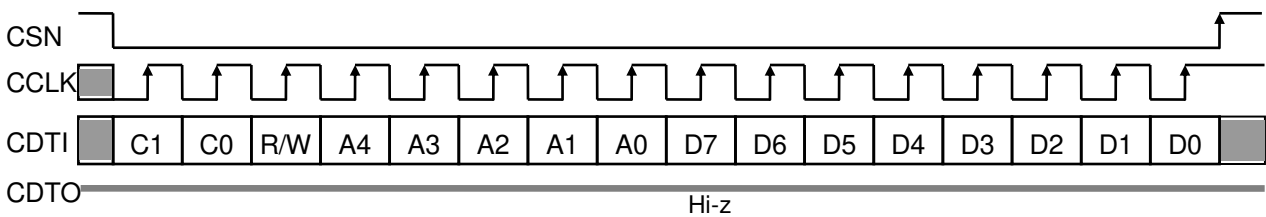

Figure 48. Write Operation

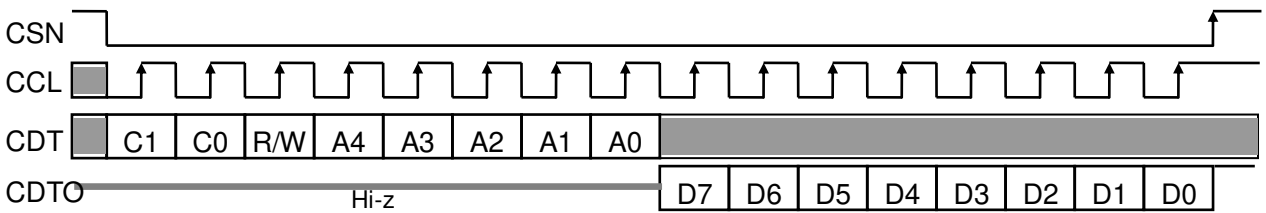

Figure 49. Read Operation

- C1-C0: Chip Address (C1 bit =CAD1 pin, C0 bit =CAD0 pin)
- R/W: READ/WRITE (Write= “1”, Read= “0”)
- A4-A0: Register Address
- D7-D0: Control Data

I²C-bus Control Mode (I2C pin = “H”)

The AK4137 supports High speed mode I2C-bus (max: 400kHz).

WRITE Operation

Figure 50 shows the data transfer sequence of the I2C-bus mode. All commands are preceded by START condition (Figure 56). A HIGH to LOW transition on the SDA line while SCL is HIGH indicates START condition (Figure 56). After the START condition, a slave address is sent. This address is 7 bits long followed by the eighth bit that is a data direction bit (R/W). The most significant five bits of the slave address are fixed as “00100”. The next 6th and 7th bits are CAD0/CAD1(device address bit). This bit identifies the specific device on the bus. The hard-wired input pin (CAD0/CAD1 pin) set these device address bits (Figure 51). If the slave address matches that of the AK4137, the AK4137 generates an acknowledge and the operation is executed. The master must generate the acknowledge-related clock pulse and release the SDA line (HIGH) during the acknowledge clock pulse (Figure 57). R/W bit = “1” indicates that the read operation is to be executed. “0” indicates that the write operation is to be executed.

The second byte consists of the control register address of the AK4137. The format is MSB first, and those most significant 3-bits are fixed to zeros (Figure 52). The data after the second byte contains control data. The format is MSB first, 8bits (Figure 53). The AK4137 generates an acknowledge after each byte is received. Data transfer is always terminated by STOP condition generated by the master. A LOW to HIGH transition on the SDA line while SCL is HIGH defines STOP condition (Figure 56).

The AK4137 can execute multiple one byte write operations in a sequence. After receipt of the third byte the AK4137 generates an acknowledge and awaits the next data. The master can transmit more than one byte instead of terminating the write cycle after the first data byte is transferred. After receiving each data packet the internal 6-bit address counter is incremented by one, and the next data is automatically taken into the next address. If the address exceeds 06H prior to generating a stop condition, the address counter will “roll over” to 00H and the previous data will be overwritten.

The data on the SDA line must remain stable during the HIGH period of the clock. The HIGH or LOW state of the data line can only change when the clock signal on the SCL line is LOW (Figure 58) except for the START and STOP conditions.

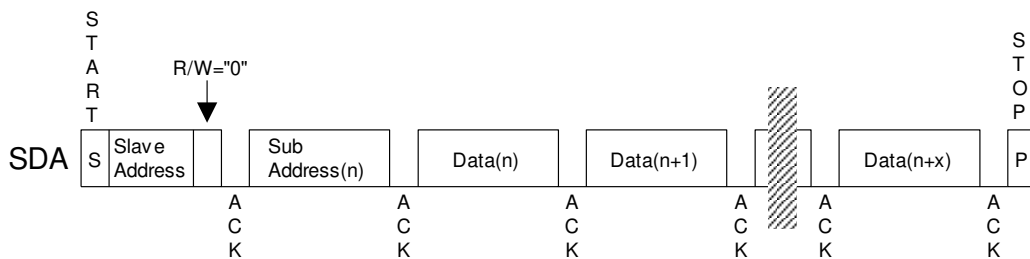

Figure 50. Data Transfer Sequence at the I²C-Bus Mode

0	0	1	0	0	CAD1	CAD0	R/W
---	---	---	---	---	------	------	-----

Figure 51. The First Byte

0	0	0	A4	A3	A2	A1	A0
---	---	---	----	----	----	----	----

Figure 52. The Second Byte

D7	D6	D5	D4	D3	D2	D1	D0
----	----	----	----	----	----	----	----

Figure 53. Byte Structure after the second byte

READ Operation

Set the R/W bit = "1" for the READ operation of the AK4137. After transmission of data, the master can read the next address's data by generating an acknowledge instead of terminating the write cycle after the receipt of the first data word. After receiving each data packet the internal 6-bit address counter is incremented by one, and the next data is automatically taken into the next address. If the address exceeds 06H prior to generating stop condition, the address counter will "roll over" to 00H and the data of 00H will be read out.

The AK4137 supports two basic read operations: Current Address Read and Random Address Read.

1. Current Address Read

The AK4137 contains an internal address counter that maintains the address of the last word accessed, incremented by one. Therefore, if the last access (either a read or write) was to address "n", the next CURRENT READ operation would access data from the address "n+1". After receipt of the slave address with R/W bit "1", the AK4137 generates an acknowledge, transmits 1-byte of data to the address set by the internal address counter and increments the internal address counter by 1. If the master does not generate an acknowledge but generates a stop condition instead, the AK4137 discontinues transmission.

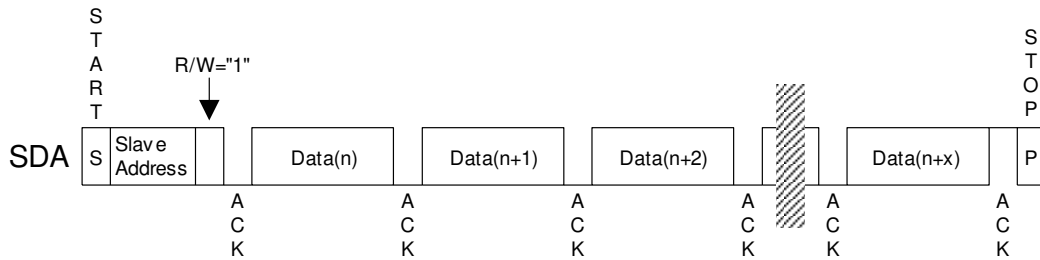

Figure 54. Current Address Read

2. Random Address Read

The random read operation allows the master to access any memory location at random. Prior to issuing a slave address with the R/W bit = "1", the master must execute a "dummy" write operation first. The master issues a start request, a slave address (R/W bit = "0") and then the register address to read. After the register address is acknowledged, the master immediately reissues the start request and the slave address with the R/W bit = "1". The AK4137 then generates an acknowledge, 1 byte of data and increments the internal address counter by 1. If the master does not generate an acknowledge but generates a stop condition instead, the AK4137 discontinues transmission.

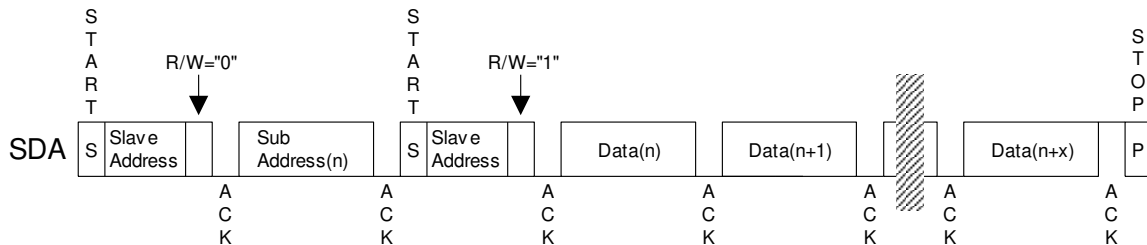

Figure 55. Random Address Read

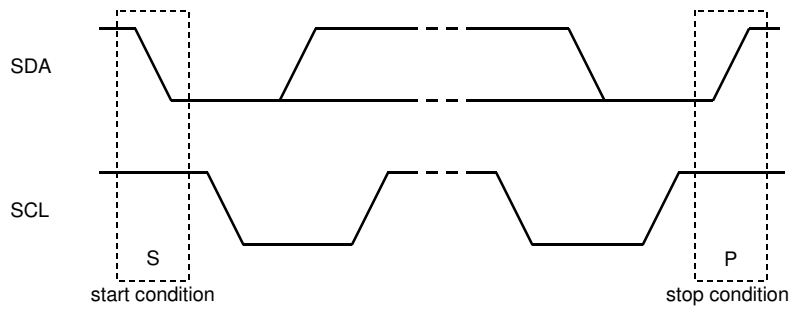

Figure 56. START and STOP Conditions

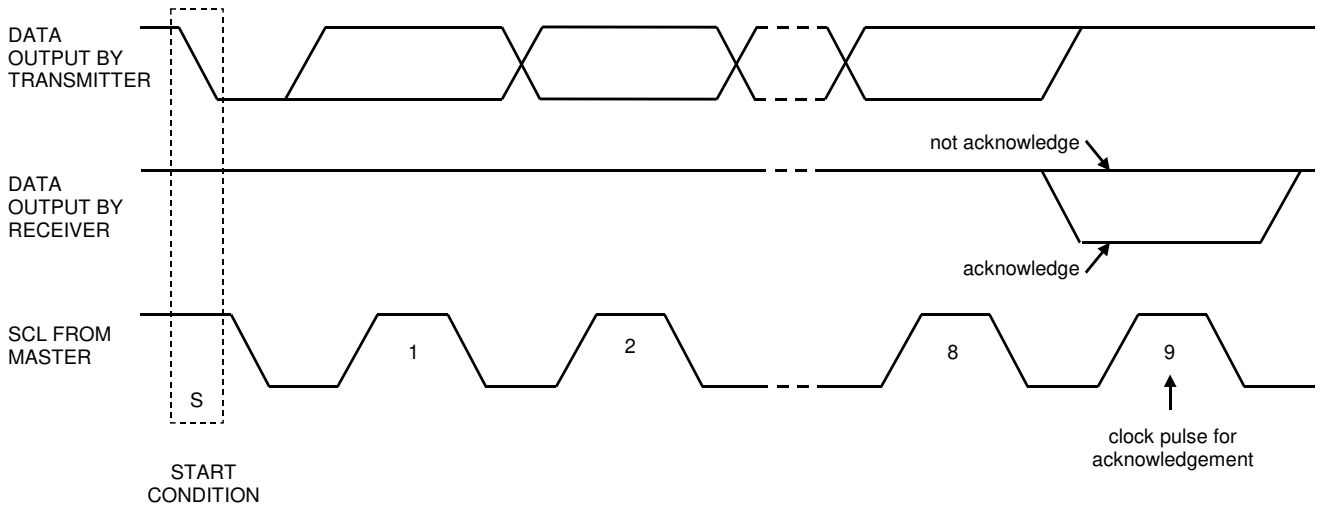

Figure 57. Acknowledge on the I²C-Bus

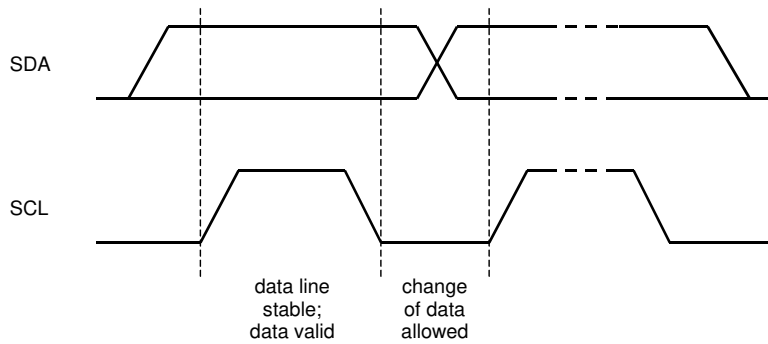

Figure 58. Bit Transfer on the I²C-Bus

The pull-up resistance of SCL and SDA pins should be connected below the voltage of DVDD+0.3V.

■ Register Map

Addr	Register Name	D7	D6	D5	D4	D3	D2	D1	D0	default
00H	Reset & Mute	0	SMT2	SMT1	SMT0	SMUTE	BYPS	FORCE STB	RSTN	0x01
01H	PCMCONT0	SLOW	SD	DEM1	DEM0	0	IDIF2	IDIF1	IDIF0	0x12
02H	PCMCONT1	0	0	0	HEXAE	ASCHON	TDMICH2	TDMICH1	TDMICH0	0x00
03H	DSDICONT	PCMFSO1	PCMFSO0	DSDIFS1	DSDIFS0	DOP	PMI	IDCKB	DSDIE	0x10
04H	DSDOCONT	DSDCLP1	DSDCLP0	DSDOFS1	DSDOFS0	ERRMASK	PMO	ODCKB	DSDOE	0x50
05H	DSDGAIN	0	0	0	0	0	0	OGAINM6	IGAIN6	0x02
06H	DSDOSTATUS	0	0	0	0	0	0	ERRINTR	ERRINTL	-

Note 36. Register values are initialized by setting the PDN pin to “L”.

Note 37. Writing to the address except 00H ~ 06H is prohibited. The bits defined as 0 must contain a “0” value.

Note 38. μ P interface access becomes valid 5ms (max) after from the PDN pin “ \uparrow ”.

■ Register Definitions

Addr	Register Name	D7	D6	D5	D4	D3	D2	D1	D0
00H	Reset & Mute	0	SMT2	SMT1	SMT0	SMUTE	BYPSS	FORCE STB	RSTN
	R/W	R/W	R/W	R/W	R/W	R/W	R/W	R/W	R/W
	Default	0	0	0	0	0	0	0	1

SMT2-0: Soft Mute Period

- 000: 1024/fso (default)
- 001: 2048/fso
- 010: 4096/fso
- 011: 8192/fso
- 100: 16384/fso
- 101: 32768/fso
- 110: reserved
- 111: reserved

Soft Mute Cycle is determined.

In Serial Control Mode (PSN pin = "L"), settings of the SMT1 and SMT0 pins are ignored.

In Parallel Control Mode (PSN pin = "H"), settings of the SMT1 and SMT0 pins are valid.

SMUTE: Soft Mute Control

- 0: Soft Mute Release (default)
- 1: Soft Mute

In Serial Control Mode (PSN pin = "L"), the CSN/SMUTE pin functions as the CSN pin, and SMUTE setting is ignored.

In Parallel Control Mode (PSN pin = "H"), the SMUTE pin setting is valid.

BYPSS: Bypass Mode Control ([Table 3](#))

- 0: SRC Mode (default)
- 1: SRC Bypass Mode

FORCESTB: CLKSTABLE signal (Checking signal for IRCK and OLRCK changes) is set to "1" forcibly.

- 0: Normal Operation (default)
- 1: CLKSTABLE = "1"

RSTN: Digital Reset Control

- 0: Reset
- 1: Reset Release (default)

Digital blocks are powered down by setting RSTN bit = "0". However, I²C serial control interface and control register blocks are not powered down, and control register values are not initialized. In this case, control register writing is also available. Internal oscillator that generates internal clock, regulator and reference voltage generation circuits are not powered down.

Addr	Register Name	D7	D6	D5	D4	D3	D2	D1	D0
01H	PCMCONT0	SLOW	SD	DEM1	DEM0	0	IDIF2	IDIF1	IDIF0
	R/W	R/W	R/W	R/W	R/W	R/W	R/W	R/W	R/W
	Default	0	0	0	1	0	0	1	0

SLOW: FIR1 Filter Coefficient Select

0: Sharp Roll OFF Filter (default)

1: Slow Roll OFF Filter

In Serial Control Mode (PSN pin = "L"), the SDA/CDTI/SLOW pin functions as SDA/CDTI pin and SLOW setting is ignored.

In Parallel Control Mode (PSN pin = "H"), the SLOW pin setting is valid.

SD: FIR1 Filter Coefficient Select

0: Normal Delay Filter (default)

1: Short Delay Filter

In Serial Control Mode (PSN pin = "L"), the SCL/CCLK/SD pin functions as SCL/CCLK pin and SD setting is ignored.

In Parallel Control Mode (PSN pin = "H"), the SD pin setting is valid.

DEM1, DEM0: De-emphasis Control

00: 44.1KHz

01: OFF (default)

10: 48KHz

11: 32KHz

In Parallel Control Mode (PSN pin = "H"), the setting of the DEM1 and DEM0 pins is valid.

IDIF2, IDIF1, IDIF0: Audio Interface Mode Select for Input Port (Table 2)

000: 32bit, LSB justified

001: 24bit, LSB justified

010: 32bit, MSB justified (default)

011: 32 or 16bit, I2S justified

100: TDM 32bit, MSB justified

101: TDM 32bit, I2S Compatible

110: TDM 32bit, MSB justified

111: TDM 32bit, I2S Compatible

In Parallel Control Mode (PSN pin = "H"), IDIF2, IDIF1 and IDIF0 settings are valid.

Addr	Register Name	D7	D6	D5	D4	D3	D2	D1	D0
02H	PCMCONT 1	0	0	0	HEXAE	ASCHON	TDMICH2	TDMICH1	TDMICH0
	R/W	RD	RD	RD	R/W	R/W	R/W	R/W	R/W
	Default	0	0	0	0	0	0	0	0

HEXAE: 768fs out mode for PCM

0: Normal Output Mode (default)

1: 768fs Output Mode

ASCHON: Auto Input Source Change Mode ON

0: Auto Input Source Change Mode OFF (default)

1: Auto Input Source Change Mode ON

TDMICH2, TDMICH1, TDMICH0: TDM Input Mode Channel Select

• 256fs Mode

000: Ch1 (Lch), Ch2 (Rch) (default)

001: Ch3 (Lch), Ch4 (Rch)

010: Ch5 (Lch), Ch6 (Rch)

011: Ch7 (Lch), Ch8 (Rch)

100: Ch1 (Lch), Ch2 (Rch)

101: Ch3 (Lch), Ch4 (Rch)

110: Ch5 (Lch), Ch6 (Rch)

111: Ch7 (Lch), Ch8 (Rch)

• 512fs Mode

000: Ch1 (Lch), Ch2 (Rch) (default)

001: Ch3 (Lch), Ch4 (Rch)

010: Ch5 (Lch), Ch6 (Rch)

011: Ch7 (Lch), Ch8 (Rch)

100: Ch9 (Lch), Ch10 (Rch)

101: Ch11 (Lch), Ch12 (Rch)

110: Ch13 (Lch), Ch14 (Rch)

111: Ch15 (Lch), Ch16 (Rch)

In Parallel Control Mode (PSN pin = "H"), Ch1 (Lch) and Ch2 (Rch) are selected.

Addr	Register Name	D7	D6	D5	D4	D3	D2	D1	D0
03H	DSDICONT	PCMFSO1	PCMFSO0	DSDIFS1	DSDIFS0	DOP	PMI	IDCKB	DSDIE
	R/W	R/W	R/W	R/W	R/W	R/W	R/W	R/W	R/W
	Default	0	0	0	1	0	0	0	0

PCMFSO1, PCMFSO0: PCM Output Sampling Frequency Select → Filter Select in DSD input mode

00: 44.1KHz or 48KHz (Cut Off 20KHz) (default)

01: 88.2KHz or 96KHz (Cut Off 40KHz)

10: 176.4KHz or 192KHz (Cut Off 80KHz)

11: 384KHz or more (Cut Off 100KHz)

DSDIFS1, DSDIFS0: DSD Input FS Select

00: 64fs

01: 128fs (default)

10: 256fs

11: Reserved (128fs)

DOP: DSD Over PCM (DoP) Mode Enable

0: OFF (default)

1: ON

DSDIE bit must be "0" when DOP bit = "1". If DSDIE bit is set to "1", DSD dedicated input pins become enabled.

PMI: DSD Input Phase Modulation Mode Select

0: Not Phase Modulation Mode (default)

1: Phase Modulation Mode

IDCKB: Polarity of IDCLK (DSD Input)

0: DSD data is input from IDCLK falling edge (default)

1: DSD data is input from IDCLK rising edge

DSDIE: DSD Input Enable

0: DSD Input Mode OFF (default)

1: DSD Input Mode ON

Addr	Register Name	D7	D6	D5	D4	D3	D2	D1	D0
04H	DSDOCONT	DSDCLP1	DSDCLP0	DSDOFS1	DSDOFS0	ERRMASK	PMO	ODCKB	DSDOE
R/W		R/W	R/W	R/W	R/W	R/W	R/W	R/W	R/W
Default		0	1	0	1	0	0	0	0

DSDCLP1, DSDCLP0: Clipping Process

- 00: No Clipping
- 01: with Clipping -6dB (default)
- 10: with Clipping -9dB
- 11: Reserved (with Clipping -6dB)

DSDOFS1, DSDOFS0: DSD Output FS Select

- 00: 64fs
- 01: 128fs (default)
- 10: 256fs
- 11: Reserved (128fs)

ERRMASK: MASK Reset

- 0: Error Detect and Reset (default)
- 1: Error Detect and Not Reset

PMO: DSD Output Phase Modulation Mode Select

- 0: Not Phase Modulation Mode (default)
- 1: Phase Modulation Mode

ODCKB: Polarity of ODCLK (DSD Output)

- 0: DSD data is output from ODCLK falling edge (default)
- 1: DSD data is output from ODCLK rising edge

DSDOE: DSD Output Enable

- 0: DSD Output Mode OFF (default)
- 1: DSD Output Mode ON

Addr	Register Name	D7	D6	D5	D4	D3	D2	D1	D0
05H	DSDGAIN	0	0	0	0	0	0	OGAINM6	IGAIN6
R/W		RD	RD	RD	RD	RD	RD	R/W	R/W
Default		0	0	0	0	0	0	1	0

OGAINM6: DSD OUT block in data Gain -6dB

- 0: OFF
- 1: ON (default)

IGAIN6: DSD IN Gain 6dB

- 0: OFF (default)
- 1: ON

Addr	Register Name	D7	D6	D5	D4	D3	D2	D1	D0
06H	DSDOSTATUS	0	0	0	0	0	0	ERRINTR	ERRINTL
	R/W	RD	RD	RD	RD	RD	RD	RD	RD
	Default	0	0	0	0	0	0	0	0

ERRINTR: Error Signal Detect and Reset for Rch

0: No Error

1: Error

ERRINTL: Error Signal Detect and Reset for Lch

0: No Error

1: Error

■ Grounding and Power Supply Decoupling

The AK4137 requires careful attention to power supply and grounding arrangements. Decoupling capacitors should be connected as near to the AK4137 as possible.

16. Jitter Tolerance

Figure 59 shows the jitter tolerance to ILRCK. The jitter quantity is defined by the jitter frequency and the jitter amplitude shown in Figure 59. When the jitter amplitude is 0.02UIpp or less, the AK4137 operates normally regardless of the jitter frequency.

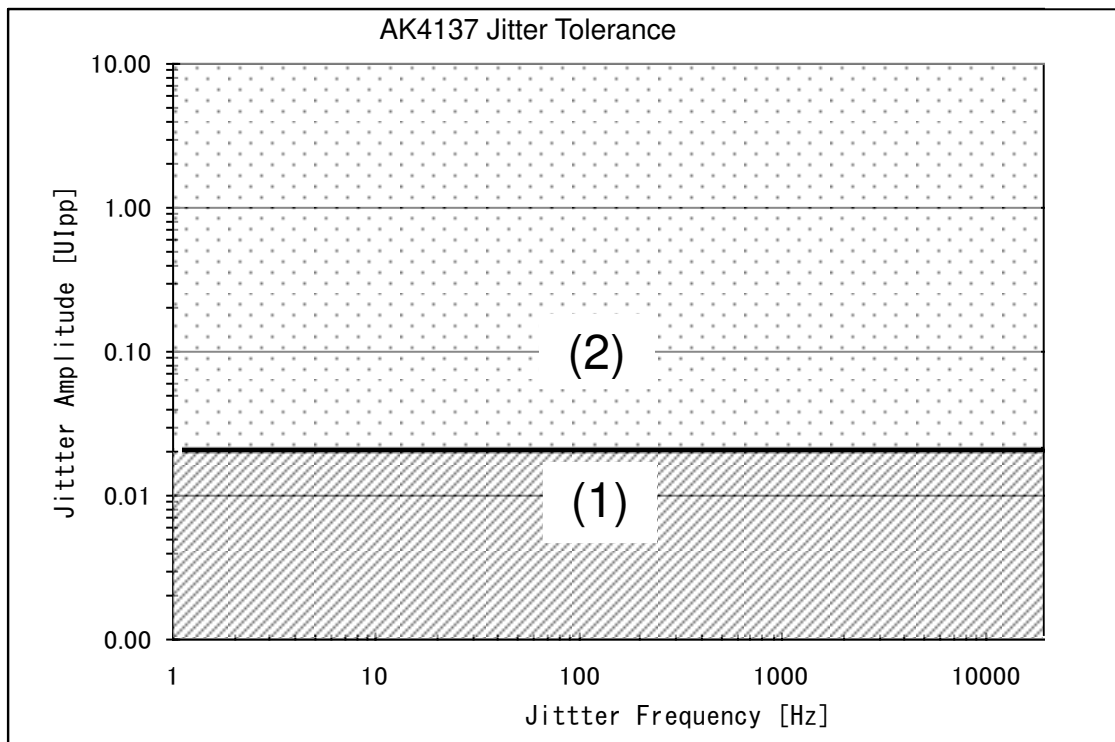

Figure 59. Jitter Tolerance

- (1) Normal Operation
- (2) There is a possibility that the output data is lost.

Note

- Y axis is the jitter amplitude of ILRCK just before THD+N degradation starts.
1UI (Unit Interval) is one cycle of ILRCK. When FSI = 48kHz, 1[UIpp]=1/48kHz =20.8μs
- This data is evaluated by adding jitter to ILRCK and IBICK, and comparing to the corresponding data input.

17. Recommended External Circuit

Figure 60 and Figure 61 shows the system connection diagram. An evaluation board (AKD4137) demonstrates application circuits, the optimum layout, power supply arrangements and measurement results.

- Serial Control mode (PSN pin = “L”)
- 4-wire serial Control Mode, Chip Address = “00”
- XT1/XTO = 64FSO, X’tal is used
- Input PORT: Slave mode, IBICK, 64FSI
Input audio interface format can be set by registers.
- Output PORT: Master mode, 32 or 16 bit I2S Compatible BICK, MCKO = 64FSO (mode8).
- Dither = OFF, De-emphasis filter can be switched ON/OFF

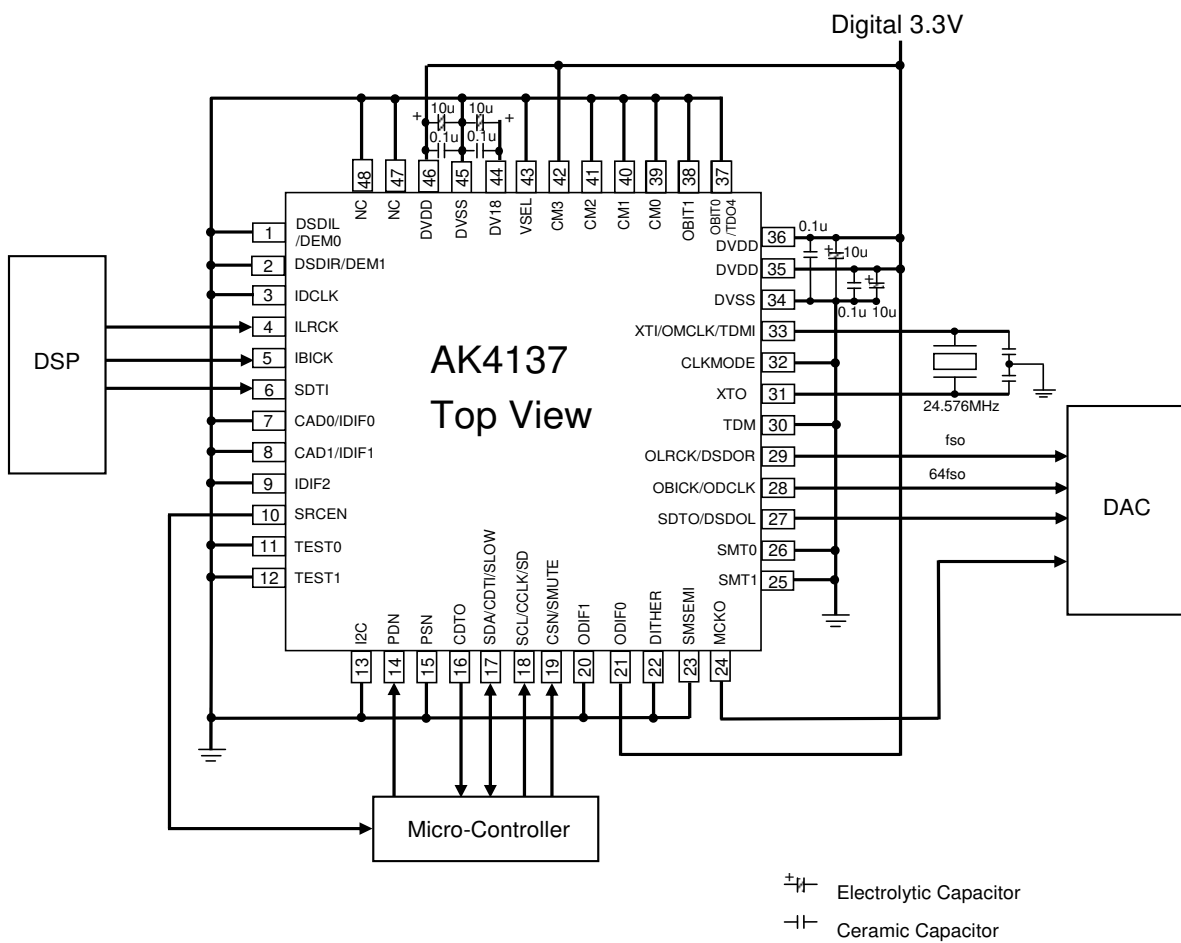

Notes:

- DVSS of the AK4137 must be distributed separately from the ground of external controllers.
- All digital input pins should not be allowed to float.
- Refer to Table 1 for the capacitor values near the X’tal.

Figure 60. Typical Connection Diagram (Serial mode)

- Parallel Control Mode (PSN pin = "H").
- XTI/XTO = 64FSO, X'tal is used
- Input PORT: Slave mode, IBICK, 64FSI
Input audio interface format can be set by registers.
- Output PORT: Master mode, 32 or 16 bit I2S Compatible BICK, MCKO = 64FSO (mode8).
- Dither = OFF, De-emphasis filter can be switched ON/OFF

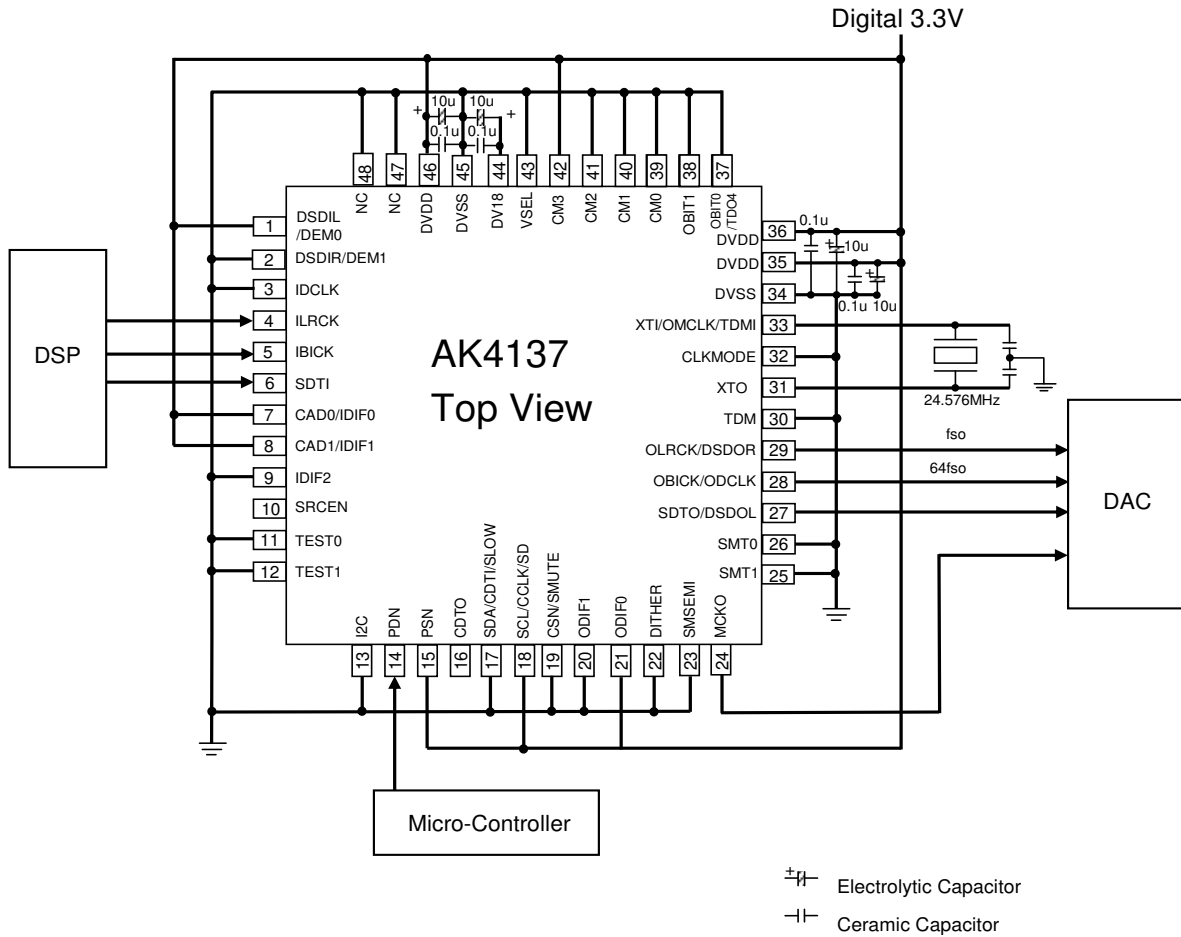

Notes:

- DVSS of the AK4137 must be distributed separately from the ground of external controllers.
- All digital input pins should not be allowed to float.
- Refer to [Table 1](#) for the capacitor values near the X'tal.

Figure 61. Typical Connection Diagram (parallel control mode)

18. Package

■ Outline Dimensions

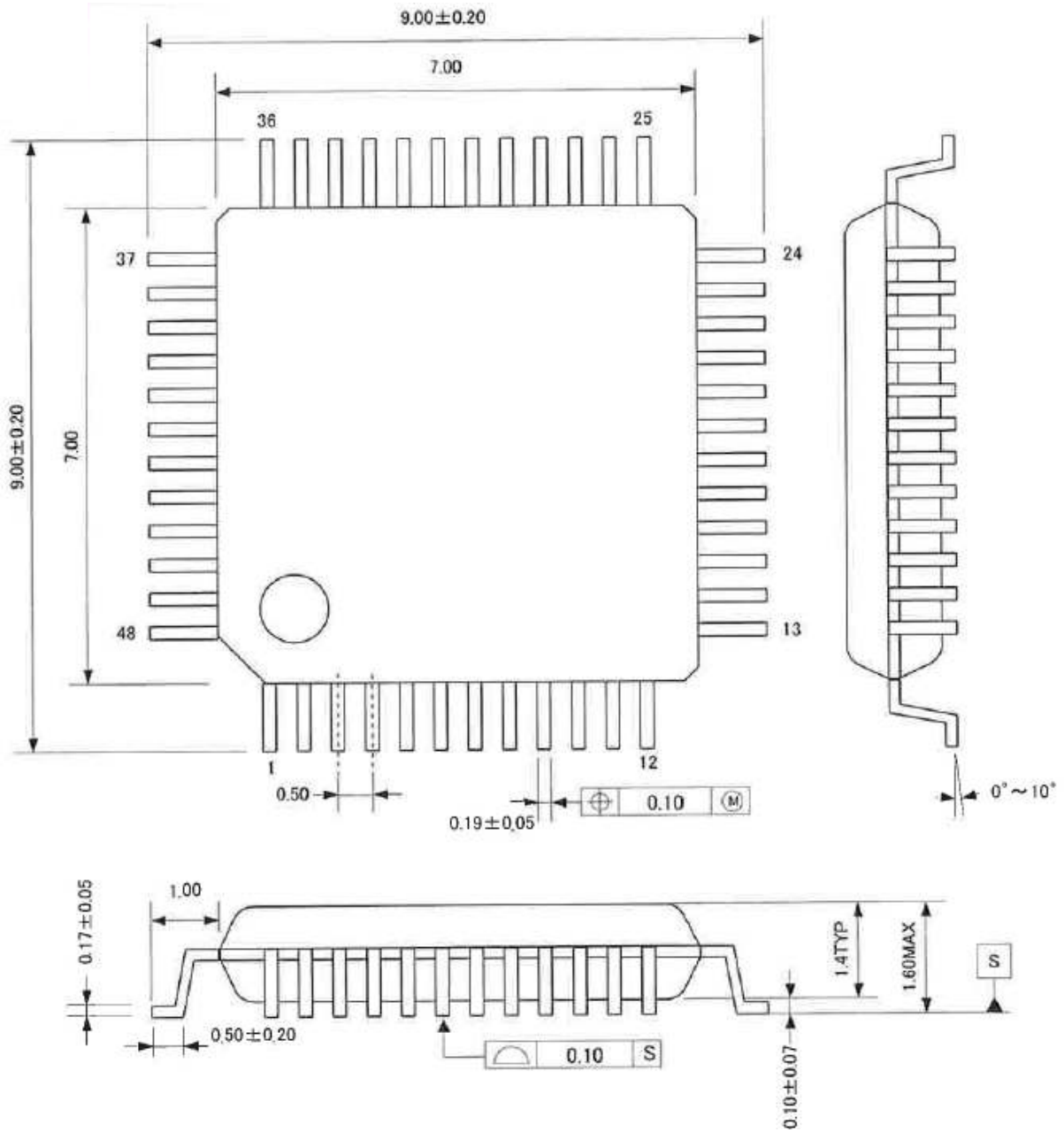

■ Material & Lead Finish

- Package molding compound: Epoxy
- Lead frame material: Cu
- Pin surface treatment: Solder (Pb free) plate

■ **Marking**

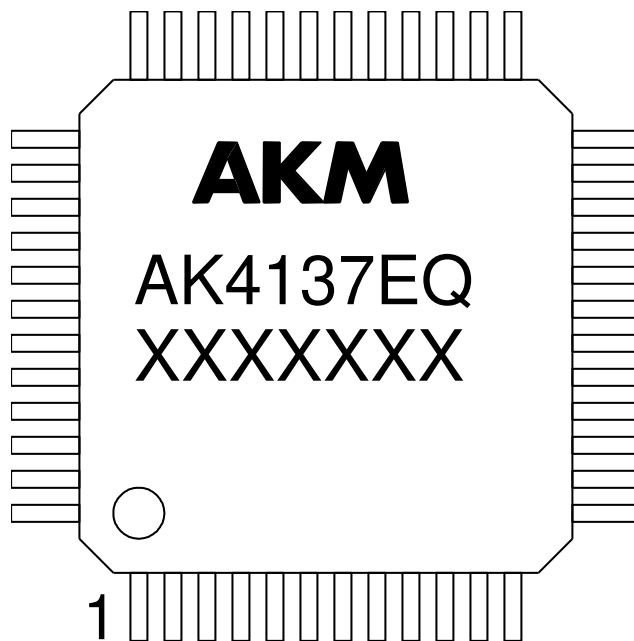

XXXXXXX: Date code identifier

19. Ordering Guide

■ **Ordering Guide**

AK4137EQ	-40 to +105 °C	48-pin LQFP (0.5 mm pitch)
AKD4137	Evaluation Board for AK4137	

20. Revision History

Date (Y/M/D)	Revision	Reason	Page	Contents
15/07/23	00	First Edition		
22/03/02	01	Specification Change	11	6. Absolute Maximum Ratings: Digital Input Voltage DVDD+0.3 → (DVDD+0.3) or 4.3
		Specification Change	12	PCMIN->PCMOUT THD+N FSO/FSI=44.1kHz/48kHz → 48kHz/48kHz Dynamic Range FSO/FSI=44.1kHz/48kHz → 48kHz/48kHz Worst Case (FSO/FSI=48kHz/32kHz) → Worst Case (FSO/FSI=32kHz/176.4kHz) Dynamic Range (A-weighted) FSO/FSI=44.1kHz/48kHz → 8kHz/48kHz
		Error Condition	12	PCMIN->DSDOUT: THD+N, Dynamic Range 2.822MHz → 2.8224MHz
		Error Condition	32	Figure 9: "TDM256 or TDM512 Master mode" was removed.
		Error Condition	37	AK137 → AK4137
		Description Addition	42	Note 25 Below description is added. In case parallel control mode, L1 and R1 are selected data channels in TDM input mode. In case serial control mode, the data channels are selected by TDMICH2-0 bits setting in TDM input mode. Mode 4 and 5 (TDM256), R1 is available in below frequency range. ILRCK: 8kHz to 18kHz, 21.8295kHz to 36kHz, 43.4385kHz to 71.5kHz, 86.436kHz to 96kHz Mode 6 and 7 (TDM512), R1 is available in below frequency range. ILRCK: 8kHz to 9kHz Mode 6 and 7 (TDM512), in case TDMICH2-0bit = "001" (just Parallel Control mode), R2 is available in below frequency range. ILRCK: 8kHz to 18kHz, 21.8295kHz to 36kHz, 43.4385kHz to 48kHz Regarding L1, R1 and R2, please refer Figure 26 , Figure 27 , Figure 28 and Figure 29 .
		Error Condition	53	Figure 37: AK4127 #3 → AK4137 #3
		Error Condition	56	Explanation of SMSEMI bit was removed. ", and the setting of SMSEMI bit must be changed during RSTN bit = "0"
		Specification Change	59	Zero Input Period to Zero Patterns was changed. 128fs: 2047ODCLK → 1023ODCLK 256fs: 4095ODCLK → 1023ODCLK
		Error Condition	59	AK137 → AK4137
		Error Condition	61	Figure 45: Note 31 → Note 30, Note 32 → Note 31
Error Condition	61	Figure 46: Note 33 → Note 32, Note 34 → Note 33		

Date (Y/M/D)	Revision	Reason	Page	Contents
22/03/02	01	Specification Change	68,69	Addr 00H: D7 bit was changed. SMSEMI → 0
		Specification Change	68,70	Addr 01H: D3 bit was changed. DITHER → 0
		Error Condition	69	Addr 00H: SMT2-0 bits were changed. 100: 1024/fso (default) → 16384/fso 101: 2048/fso → 32768/fso 110: 4096/fso → reserved 111: 8192/fso → reserved
		Error Condition	71	TDMICH2-0 bits = "101" Ch2 (Lch), Ch4 (Rch) → Ch3 (Lch), Ch4 (Rch)
		Error Condition	70,71, 73,74	Register Names are changed. Addr 01H: PCMONT0 → PCMCONT0 Addr 02H: PCMCONT0 → PCMCONT1 Addr 05H: DSDCONT → DSDGAIN Addr 06H: DSDCONT → DSDSTATUS

IMPORTANT NOTICE

0. Asahi Kasei Microdevices Corporation ("AKM") reserves the right to make changes to the information contained in this document without notice. When you consider any use or application of AKM product stipulated in this document ("Product"), please make inquiries the sales office of AKM or authorized distributors as to current status of the Products.
1. All information included in this document are provided only to illustrate the operation and application examples of AKM Products. AKM neither makes warranties or representations with respect to the accuracy or completeness of the information contained in this document nor grants any license to any intellectual property rights or any other rights of AKM or any third party with respect to the information in this document. You are fully responsible for use of such information contained in this document in your product design or applications. **AKM ASSUMES NO LIABILITY FOR ANY LOSSES INCURRED BY YOU OR THIRD PARTIES ARISING FROM THE USE OF SUCH INFORMATION IN YOUR PRODUCT DESIGN OR APPLICATIONS.**
2. The Product is neither intended nor warranted for use in equipment or systems that require extraordinarily high levels of quality and/or reliability and/or a malfunction or failure of which may cause loss of human life, bodily injury, serious property damage or serious public impact, including but not limited to, equipment used in nuclear facilities, equipment used in the aerospace industry, medical equipment, equipment used for automobiles, trains, ships and other transportation, traffic signaling equipment, equipment used to control combustions or explosions, safety devices, elevators and escalators, devices related to electric power, and equipment used in finance-related fields. Do not use Product for the above use unless specifically agreed by AKM in writing.
3. Though AKM works continually to improve the Product's quality and reliability, you are responsible for complying with safety standards and for providing adequate designs and safeguards for your hardware, software and systems which minimize risk and avoid situations in which a malfunction or failure of the Product could cause loss of human life, bodily injury or damage to property, including data loss or corruption.
4. Do not use or otherwise make available the Product or related technology or any information contained in this document for any military purposes, including without limitation, for the design, development, use, stockpiling or manufacturing of nuclear, chemical, or biological weapons or missile technology products (mass destruction weapons). When exporting the Products or related technology or any information contained in this document, you should comply with the applicable export control laws and regulations and follow the procedures required by such laws and regulations. The Products and related technology may not be used for or incorporated into any products or systems whose manufacture, use, or sale is prohibited under any applicable domestic or foreign laws or regulations.
5. Please contact AKM sales representative for details as to environmental matters such as the RoHS compatibility of the Product. Please use the Product in compliance with all applicable laws and regulations that regulate the inclusion or use of controlled substances, including without limitation, the EU RoHS Directive. AKM assumes no liability for damages or losses occurring as a result of noncompliance with applicable laws and regulations.
6. Resale of the Product with provisions different from the statement and/or technical features set forth in this document shall immediately void any warranty granted by AKM for the Product and shall not create or extend in any manner whatsoever, any liability of AKM.
7. This document may not be reproduced or duplicated, in any form, in whole or in part, without prior written consent of AKM.