

MVC. Vertical toggle clamps

with double base, steel



- 1
- 2
- 3
- 4
- 5
- 6
- 7
- 8
- 9
- 10
- 11
- 12
- 13
- 14
- 15
- 16
- 17
- 18

MATERIAL

C10 zinc-plated steel.

RIVETS

Zinc-plated steel.

HANDLE

Polyurethane, red colour.

STANDARD EXECUTIONS

- **MVC-AV**: with open clamping lever and two folded washers.
- **MVC-EV**: with solid clamping lever and retainer for welding.

CLAMPING BOLTS

To be ordered separately.

FEATURES AND APPLICATIONS

All articulated joints are lubricated with special grease.
 MVC. toggle clamps can be mounted on two different surfaces and occupy a limited space for clamping as lever and arm move in two opposite directions.

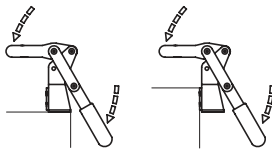
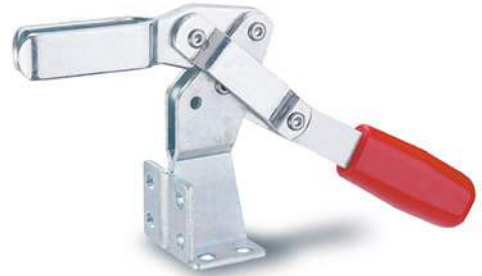

MVC-AV



MVC-EV

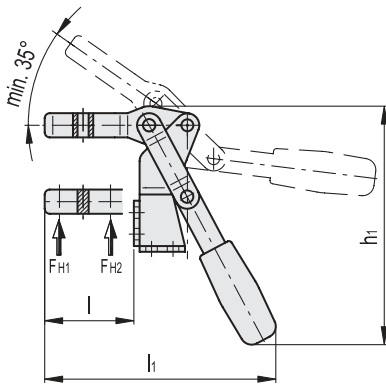

MVC-AV

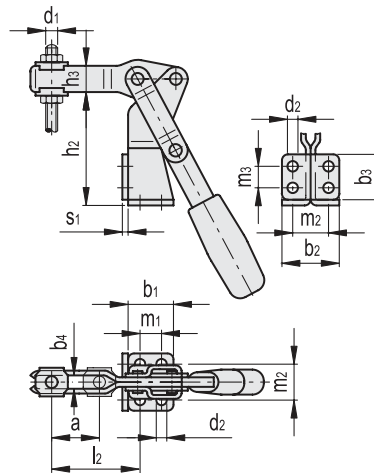

MVC-EV

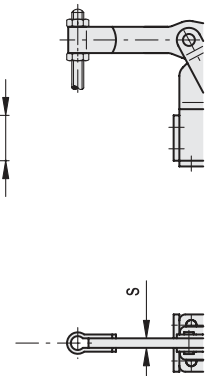

METRIC

MVC-AV

Code	Description	a	b1	b2	b3	b4	d1	d2	h1	h2	h3	l	l1	l2	m1	m2	m3	s1	FH1 [N]*	FH2 [N]*	Δ
GG.AA220	MVC.200-AV	34	32	38	32	8.5	M8	6.5	154	74	17	58.5	157	59	16	26	16	3	1200	2400	430
GG.AA320	MVC.300-AV	42	45	48	48	10.4	M10	8.5	198	108	20	76	193	74	28	30	30	3	1900	2800	800

METRIC

MVC-EV

Code	Description	b1	b2	b3	d1	d2	h1	h2	h3	l	l1	m1	m2	m3	s	s1	FH1 [N]*	FH2 [N]*	Δ
GG.AA225	MVC.200-EV	32	38	32	M8	6.5	154	74	17	60.5	159	16	26	16	6	3	1200	2400	430
GG.AA325	MVC.300-EV	45	48	48	M10	8.5	198	108	20	78	195	28	30	30	8	3	1900	2800	800

Toggle clamps

* Holding force.