

ecoSWITCH™

Advanced Load Management

Controlled Load Switch with Low R_{ON}

NCP45524, NCP45525

The NCP4552x series of load switches provide a component and area-reducing solution for efficient power domain switching with inrush current limit via soft start. These devices are designed to integrate control and driver functionality with a high performance low on-resistance power MOSFET in a single package. This cost effective solution is ideal for power management and hot-swap applications requiring low power consumption in a small footprint.

Features

- Advanced Controller with Charge Pump
- Integrated N-Channel MOSFET with Low R_{ON}
- Input Voltage Range 0.5 V to 13.5 V
- Soft-Start via Controlled Slew Rate
- Adjustable Slew Rate Control (NCP45525)
- Power Good Signal (NCP45524)
- Extremely Low Standby Current
- Load Bleed (Quick Discharge)
- This is a Pb-Free Device

Typical Applications

- Portable Electronics and Systems
- Notebook and Tablet Computers
- Telecom, Networking, Medical, and Industrial Equipment
- Set-Top Boxes, Servers, and Gateways
- Hot Swap Devices and Peripheral Ports

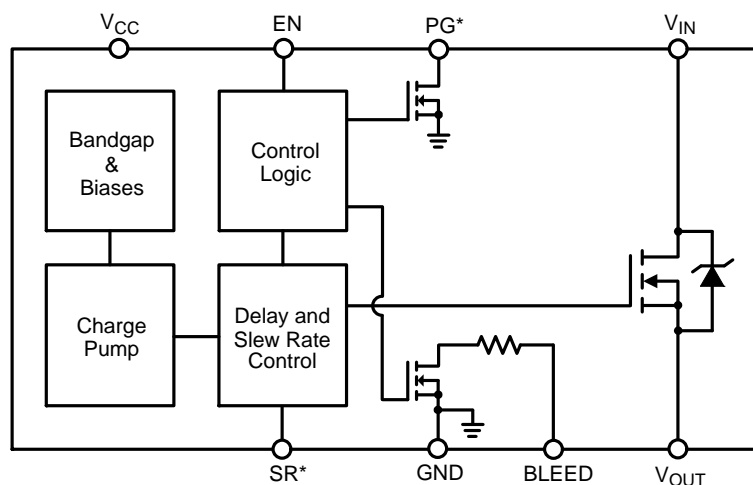

Figure 1. Block Diagram

(*Note: either PG or SR available for each part)



ON Semiconductor®

www.onsemi.com

| R _{ON} TYP | V _{CC} | V _{IN} | I _{MAX_DC} * |
|---------------------|-----------------|-----------------|-----------------------|
| 18.0 mΩ | 3.3 V | 1.8 V | 6 A |
| 18.8 mΩ | 3.3 V | 5.0 V | |
| 21.9 mΩ | 3.3 V | 12 V | |

*I_{MAX_DC} is defined as the maximum steady state current the load switch can pass at room ambient temperature without entering thermal lockout.

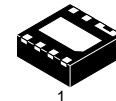

DFN8, 2x2
CASE 506CC

MARKING DIAGRAM

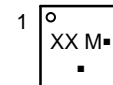

XX = 4H for NCP45524-H
 = 4L for NCP45524-L
 = 5H for NCP45525-H
 = 5L for NCP45525-L

M = Date Code
 ■ = Pb-Free Package

(Note: Microdot may be in either location)

PIN CONFIGURATION

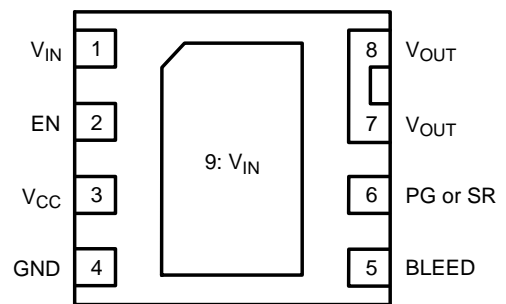

(Top View)

ORDERING INFORMATION

See detailed ordering and shipping information on page 14 of this data sheet.

NCP45524, NCP45525

Table 1. PIN DESCRIPTION

| Pin | Name | Function |
|------|------------------|--|
| 1, 9 | V _{IN} | Drain of MOSFET (0.5 V – 13.5 V), Pin 1 must be connected to Pin 9 |
| 2 | EN | NCP45524–H & NCP45525–H – Active–high digital input used to turn on the MOSFET, pin has an internal pull down resistor to GND |
| | | NCP45524–L & NCP45525–L – Active–low digital input used to turn on the MOSFET, pin has an internal pull up resistor to V _{CC} |
| 3 | V _{CC} | Supply voltage to controller (3.0 V – 5.5 V) |
| 4 | GND | Controller ground |
| 5 | BLEED | Load bleed connection; must be tied to V _{OUT} either directly or through a resistor ≤ 100 MΩ. |
| 6 | PG | NCP45524 – Active–high, open–drain output that indicates when the gate of the MOSFET is fully charged, external pull up resistor ≥ 1 kΩ to an external voltage source required; tie to GND if not used |
| | SR | NCP45525 – Slew rate adjustment; float if not used |
| 7, 8 | V _{OUT} | Source of MOSFET connected to load |

Table 2. ABSOLUTE MAXIMUM RATINGS

| Rating | Symbol | Value | Unit |
|---|------------------------|---------------------------------|------------|
| Supply Voltage Range | V _{CC} | –0.3 to 6 | V |
| Input Voltage Range | V _{IN} | –0.3 to 18 | V |
| Output Voltage Range | V _{OUT} | –0.3 to 18 | V |
| EN Digital Input Range | V _{EN} | –0.3 to (V _{CC} + 0.3) | V |
| PG Output Voltage Range (Note 1) | V _{PG} | –0.3 to 6 | V |
| Thermal Resistance, Junction–to–Ambient, Steady State (Note 2) | R _{θJA} | 40.0 | °C/W |
| Thermal Resistance, Junction–to–Ambient, Steady State (Note 3) | R _{θJA} | 72.7 | °C/W |
| Thermal Resistance, Junction–to–Case (V _{IN} Paddle) | R _{θJC} | 5.3 | °C/W |
| Continuous MOSFET Current @ T _A = 25°C | I _{MAX} | 6.0 | A |
| Transient MOSFET Current (for up to 500 μs) | I _{MAX_TRANS} | 24 | A |
| Total Power Dissipation @ T _A = 25°C (Notes 2 and 4) Derate above T _A = 25°C | P _D | 2.50 24.9 | W mW/°C |
| Total Power Dissipation @ T _A = 25°C (Notes 3 and 4) Derate above T _A = 25°C | P _D | 1.37 13.8 | W mW/°C |
| Storage Temperature Range | T _{STG} | –40 to 150 | °C |
| Lead Temperature, Soldering (10 sec.) | T _{SLD} | 260 | °C |
| ESD Capability, Human Body Model (Notes 5 and 6) | ESD _{HBM} | 3.0 | kV |
| ESD Capability, Machine Model (Note 5) | ESD _{MM} | 200 | V |
| ESD Capability, Charged Device Model (Note 5) | ESD _{CDM} | 1.0 | kV |
| Latch–up Current Immunity (Notes 5 and 6) | LU | 100 | mA |

Stresses exceeding those listed in the Maximum Ratings table may damage the device. If any of these limits are exceeded, device functionality should not be assumed, damage may occur and reliability may be affected.

1. NCP45524 only. PG is an open–drain output that requires an external pull up resistor ≥ 1 kΩ to an external voltage source.
2. Surface–mounted on FR4 board using 1 sq–in pad, 1 oz Cu.
3. Surface–mounted on FR4 board using the minimum recommended pad size, 1 oz Cu.
4. Specified for derating purposes only, ensure that I_{MAX} is never exceeded.
5. Tested by the following methods @ T_A = 25°C:
 - ESD Human Body Model tested per JESD22–A114
 - ESD Machine Model tested per JESD22–A115
 - ESD Charged Device Model tested per JESD22–C101
 - Latch–up Current tested per JESD78
6. Rating is for all pins except for V_{IN} and V_{OUT} which are tied to the internal MOSFET’s Drain and Source. Typical MOSFET ESD performance for V_{IN} and V_{OUT} should be expected and these devices should be treated as ESD sensitive.

NCP45524, NCP45525

Table 3. RECOMMENDED OPERATING RANGES

| Rating | Symbol | Min | Max | Unit |
|---|-------------|-----|------|------|
| Supply Voltage | V_{CC} | 3 | 5.5 | V |
| Input Voltage | V_{IN} | 0.5 | 13.5 | V |
| Ground | GND | | 0 | V |
| Ambient Temperature | T_A | -40 | 85 | °C |
| Junction Temperature | T_J | -40 | 125 | °C |
| OFF to ON Transition Energy Dissipation Limit (See application section) | E_{TRANS} | 0 | 100 | mJ |

Functional operation above the stresses listed in the Recommended Operating Ranges is not implied. Extended exposure to stresses beyond the Recommended Operating Ranges limits may affect device reliability.

Table 4. ELECTRICAL CHARACTERISTICS ($T_J = 25^\circ\text{C}$ unless otherwise specified)

| Parameter | Conditions (Note 7) | Symbol | Min | Typ | Max | Unit |
|--------------------------------------|--|-------------|-----|------|------|---------------|
| MOSFET | | | | | | |
| On-Resistance | $V_{CC} = 3.3\text{ V}; V_{IN} = 1.8\text{ V}$ | R_{ON} | | 18.0 | 24.0 | m Ω |
| | $V_{CC} = 3.3\text{ V}; V_{IN} = 5\text{ V}$ | | | 18.8 | 25.0 | |
| | $V_{CC} = 3.3\text{ V}; V_{IN} = 12\text{ V}$ | | | 21.9 | 31.7 | |
| Leakage Current (Note 8) | $V_{EN} = 0\text{ V}; V_{IN} = 13.5\text{ V}$ | I_{LEAK} | | 0.1 | 1 | μA |
| CONTROLLER | | | | | | |
| Supply Standby Current (Note 9) | $V_{EN} = 0\text{ V}; V_{CC} = 3\text{ V}$ | I_{STBY} | | 0.65 | 2 | μA |
| | $V_{EN} = 0\text{ V}; V_{CC} = 5.5\text{ V}$ | | | 3.2 | 4.5 | |
| Supply Dynamic Current (Note 10) | $V_{EN} = V_{CC} = 3\text{ V}; V_{IN} = 12\text{ V}$ | I_{DYN} | | 180 | 300 | μA |
| | $V_{EN} = V_{CC} = 5.5\text{ V}; V_{IN} = 1.8\text{ V}$ | | | 475 | 680 | |
| Bleed Resistance | $V_{EN} = 0\text{ V}; V_{CC} = 3\text{ V}$ | R_{BLEED} | 86 | 115 | 144 | Ω |
| | $V_{EN} = 0\text{ V}; V_{CC} = 5.5\text{ V}$ | | 72 | 97 | 121 | |
| EN Input High Voltage | $V_{CC} = 3\text{ V} - 5.5\text{ V}$ | V_{IH} | 2 | | | V |
| EN Input Low Voltage | $V_{CC} = 3\text{ V} - 5.5\text{ V}$ | V_{IL} | | | 0.8 | V |
| EN Input Leakage Current | NCP45524-H; NCP45525-H; $V_{EN} = 0\text{ V}$ | I_{IL} | | 90 | 500 | nA |
| | NCP45524-L; NCP45525-L; $V_{EN} = 5.5\text{ V}$ | I_{IH} | | 90 | 500 | |
| EN Pull Down Resistance | NCP45524-H; NCP45525-H | R_{PD} | 76 | 100 | 124 | k Ω |
| EN Pull Up Resistance | NCP45524-L; NCP45525-L | R_{PU} | 76 | 100 | 124 | k Ω |
| PG Output Low Voltage (Note 11) | NCP45524; $V_{CC} = 3\text{ V}; I_{SINK} = 5\text{ mA}$ | V_{OL} | | | 0.2 | V |
| PG Output Leakage Current (Note 12) | NCP45524; $V_{CC} = 3\text{ V}; V_{TERM} = 3.3\text{ V}$ | I_{OH} | | 5 | 100 | nA |
| Slew Rate Control Constant (Note 13) | NCP45525; $V_{CC} = 3\text{ V}$ | K_{SR} | 24 | 31 | 38 | μA |

Product parametric performance is indicated in the Electrical Characteristics for the listed test conditions, unless otherwise noted. Product performance may not be indicated by the Electrical Characteristics if operated under different conditions.

7. V_{EN} shown only for NCP45524-H, NCP45525-H (EN Active-High) unless otherwise specified.

8. Average current from V_{IN} to V_{OUT} with MOSFET turned off.

9. Average current from V_{CC} to GND with MOSFET turned off.

10. Average current from V_{CC} to GND after charge up time of MOSFET.

11. PG is an open-drain output that is pulled low when the MOSFET is disabled.

12. PG is an open-drain output that is not driven when the gate of the MOSFET is fully charged, requires an external pull up resistor $\geq 1\text{ k}\Omega$ to an external voltage source, V_{TERM} .

13. See Applications Information section for details on how to adjust the slew rate.

NCP45524, NCP45525

Table 5. SWITCHING CHARACTERISTICS ($T_J = 25^\circ\text{C}$ unless otherwise specified) (Notes 14 and 15)

| Parameter | Conditions | Symbol | Min | Typ | Max | Unit |
|------------------------------------|--|--------------|-----|------|-----|---------------|
| Output Slew Rate (Note 16) | $V_{CC} = 3.3\text{ V}; V_{IN} = 1.8\text{ V}$ | SR | | 11.9 | | kV/s |
| | $V_{CC} = 5.0\text{ V}; V_{IN} = 1.8\text{ V}$ | | | 12.1 | | |
| | $V_{CC} = 3.3\text{ V}; V_{IN} = 12\text{ V}$ | | | 13.5 | | |
| | $V_{CC} = 5.0\text{ V}; V_{IN} = 12\text{ V}$ | | | 13.9 | | |
| Output Turn-on Delay (Note 16) | $V_{CC} = 3.3\text{ V}; V_{IN} = 1.8\text{ V}$ | T_{ON} | | 220 | | μs |
| | $V_{CC} = 5.0\text{ V}; V_{IN} = 1.8\text{ V}$ | | | 185 | | |
| | $V_{CC} = 3.3\text{ V}; V_{IN} = 12\text{ V}$ | | | 270 | | |
| | $V_{CC} = 5.0\text{ V}; V_{IN} = 12\text{ V}$ | | | 260 | | |
| Output Turn-off Delay (Note 16) | $V_{CC} = 3.3\text{ V}; V_{IN} = 1.8\text{ V}$ | T_{OFF} | | 1.2 | | μs |
| | $V_{CC} = 5.0\text{ V}; V_{IN} = 1.8\text{ V}$ | | | 0.9 | | |
| | $V_{CC} = 3.3\text{ V}; V_{IN} = 12\text{ V}$ | | | 0.4 | | |
| | $V_{CC} = 5.0\text{ V}; V_{IN} = 12\text{ V}$ | | | 0.2 | | |
| Power Good Turn-on Time (Note 17) | $V_{CC} = 3.3\text{ V}; V_{IN} = 1.8\text{ V}$ | $T_{PG,ON}$ | | 0.91 | | ms |
| | $V_{CC} = 5.0\text{ V}; V_{IN} = 1.8\text{ V}$ | | | 0.93 | | |
| | $V_{CC} = 3.3\text{ V}; V_{IN} = 12\text{ V}$ | | | 1.33 | | |
| | $V_{CC} = 5.0\text{ V}; V_{IN} = 12\text{ V}$ | | | 1.21 | | |
| Power Good Turn-off Time (Note 17) | $V_{CC} = 3.3\text{ V}; V_{IN} = 1.8\text{ V}$ | $T_{PG,OFF}$ | | 21 | | ns |
| | $V_{CC} = 5.0\text{ V}; V_{IN} = 1.8\text{ V}$ | | | 15 | | |
| | $V_{CC} = 3.3\text{ V}; V_{IN} = 12\text{ V}$ | | | 21 | | |
| | $V_{CC} = 5.0\text{ V}; V_{IN} = 12\text{ V}$ | | | 15 | | |

14. See below figure for Test Circuit and Timing Diagram.

15. Tested with the following conditions: $V_{TERM} = V_{CC}$; $R_{PG} = 100\text{ k}\Omega$; $R_L = 10\ \Omega$; $C_L = 0.1\ \mu\text{F}$.

16. Applies to NCP45524 and NCP45525.

17. Applies only to NCP45524.

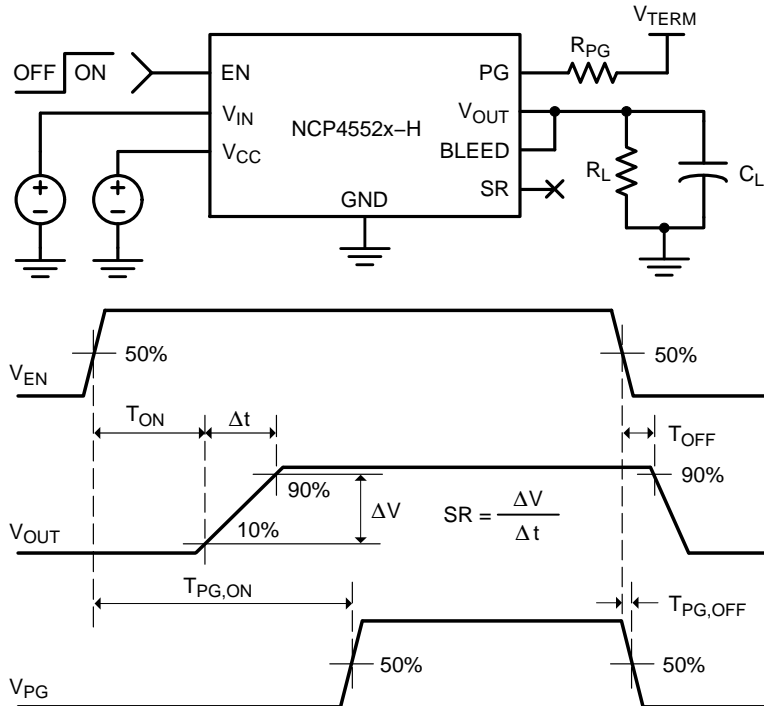

Figure 2. Switching Characteristics Test Circuit and Timing Diagram

NCP45524, NCP45525

TYPICAL CHARACTERISTICS

($T_J = 25^\circ\text{C}$ unless otherwise specified)

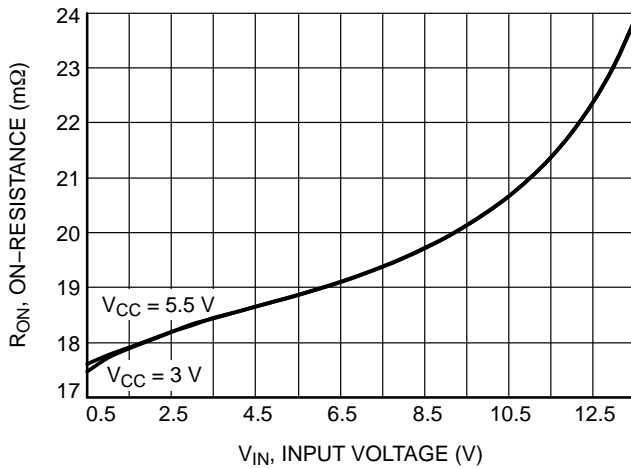

Figure 3. On-Resistance vs. Input Voltage

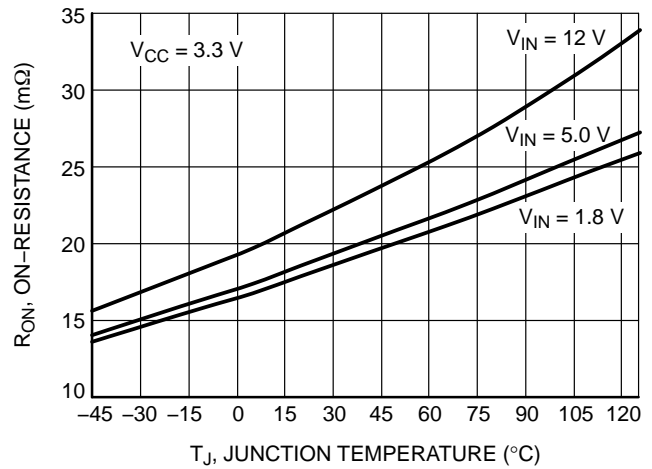

Figure 4. On-Resistance vs. Temperature

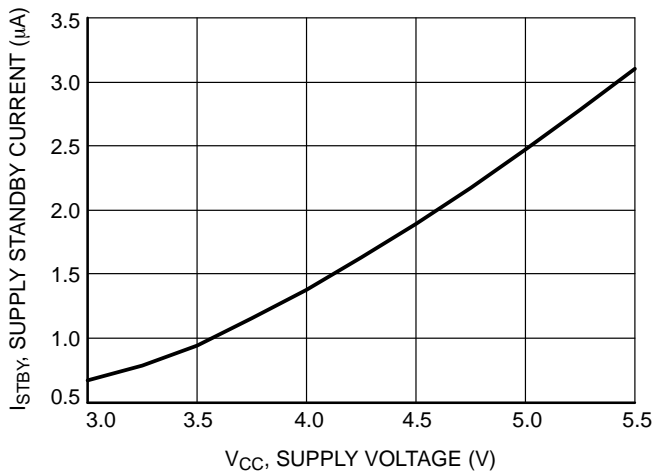

Figure 5. Supply Standby Current vs. Supply Voltage

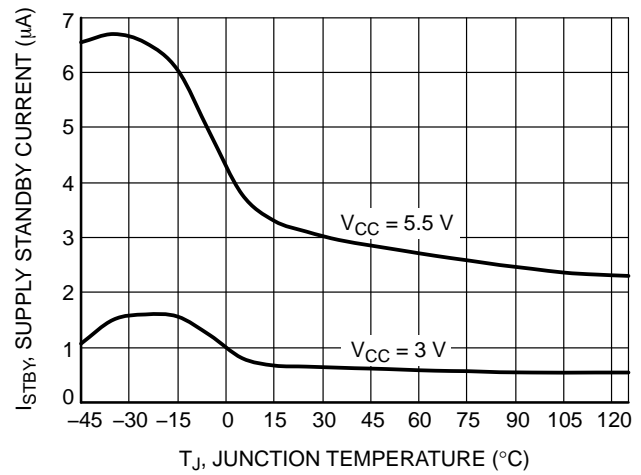

Figure 6. Supply Standby Current vs. Temperature

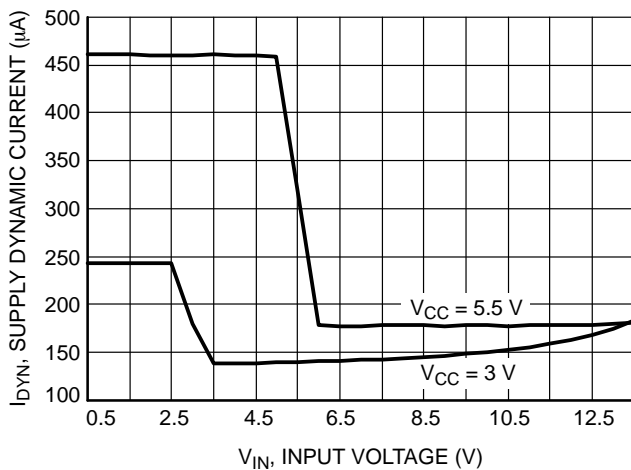

Figure 7. Supply Dynamic Current vs. Input Voltage

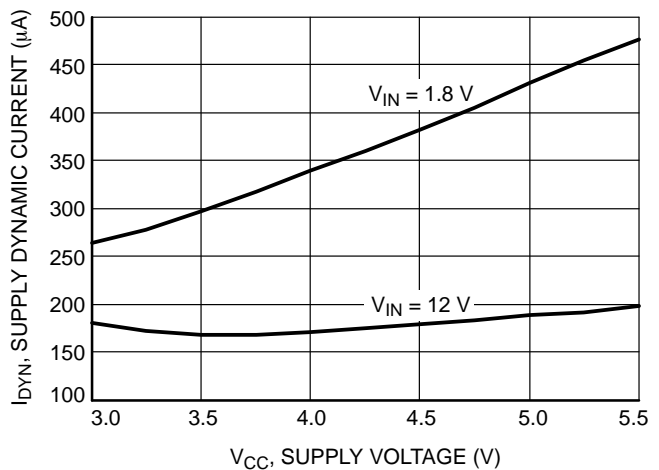

Figure 8. Supply Dynamic Current vs. Supply Voltage

NCP45524, NCP45525

TYPICAL CHARACTERISTICS

($T_J = 25^\circ\text{C}$ unless otherwise specified)

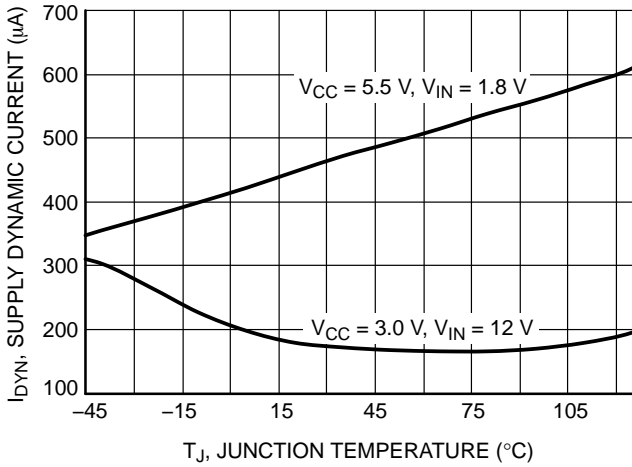

Figure 9. Supply Dynamic Current vs. Temperature

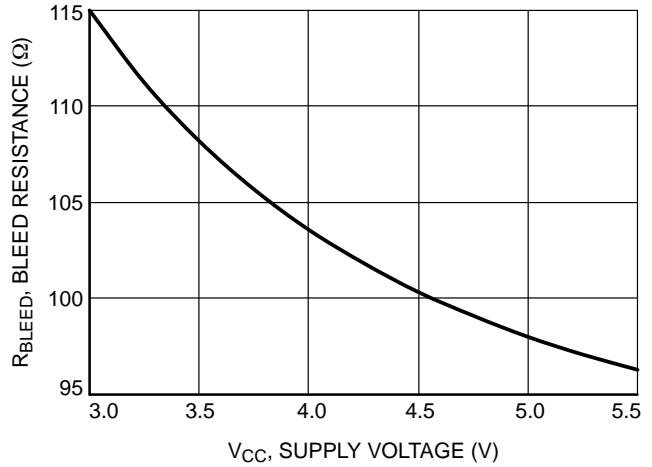

Figure 10. Bleed Resistance vs. Supply Voltage

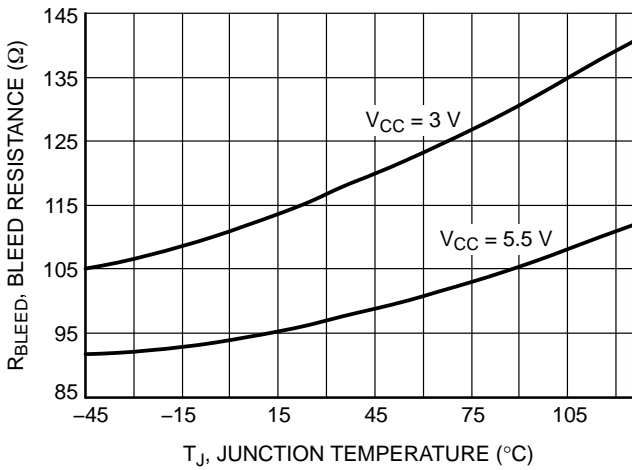

Figure 11. Bleed Resistance vs. Temperature

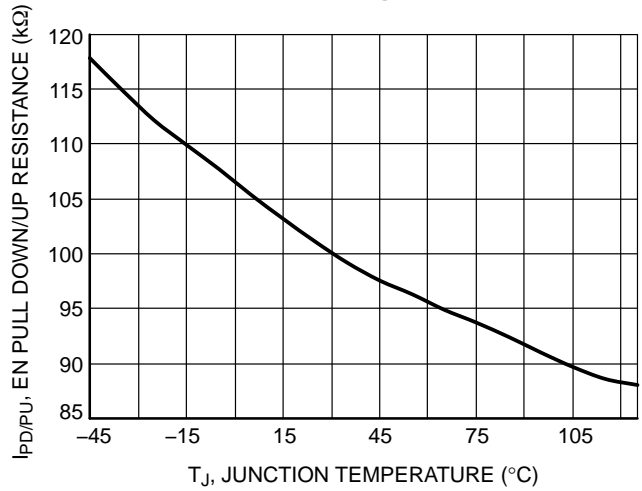

Figure 12. EN Pull Down/Up Resistance vs. Temperature

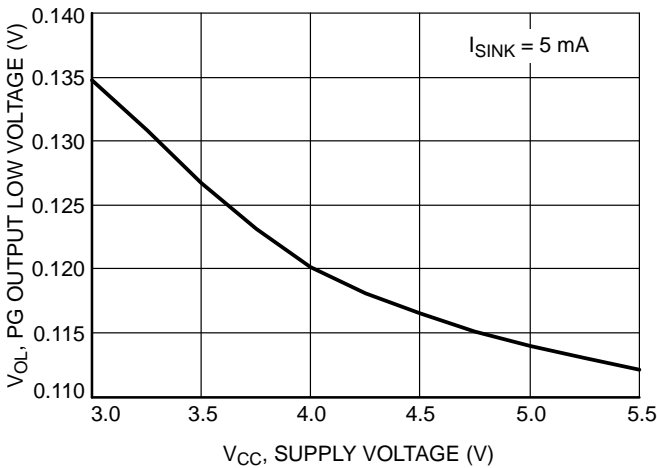

Figure 13. PG Output Low Voltage vs. Supply Voltage

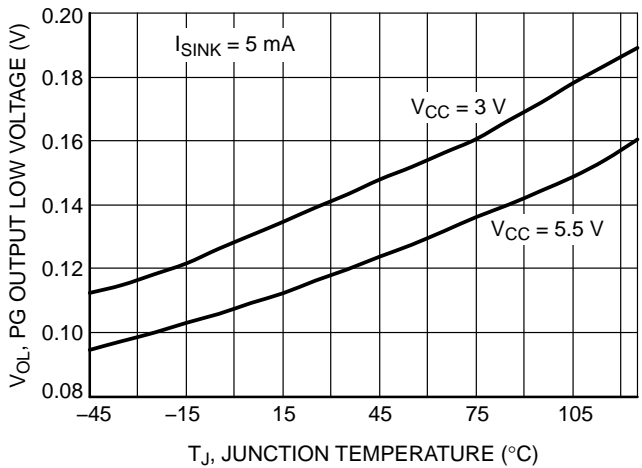

Figure 14. PG Output Low Voltage vs. Temperature

NCP45524, NCP45525

TYPICAL CHARACTERISTICS

($T_J = 25^\circ\text{C}$ unless otherwise specified)

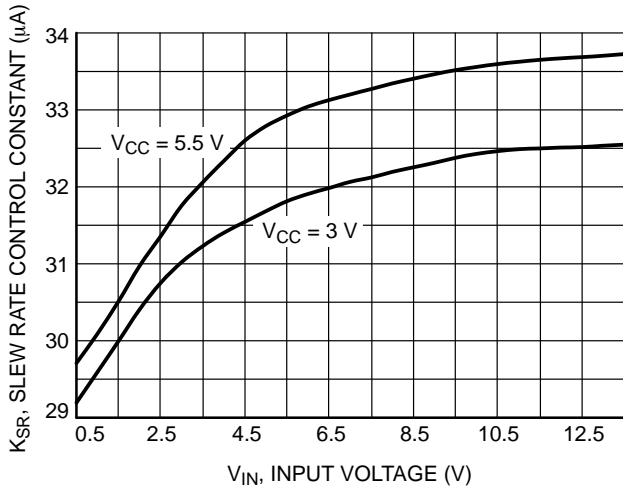

Figure 15. Slew Rate Control Constant vs. Input Voltage

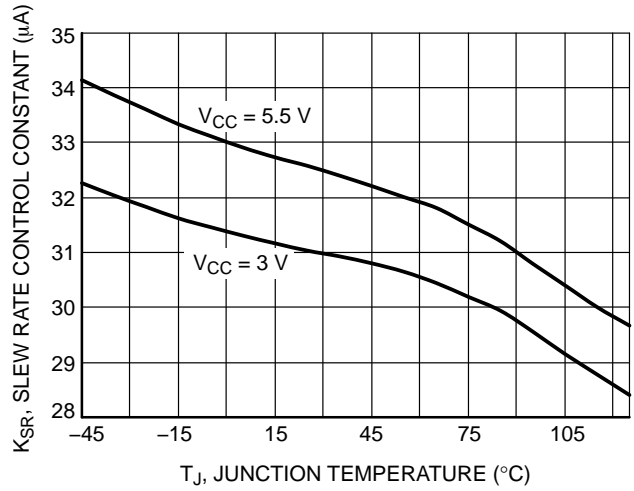

Figure 16. Slew Rate Control Constant vs. Temperature

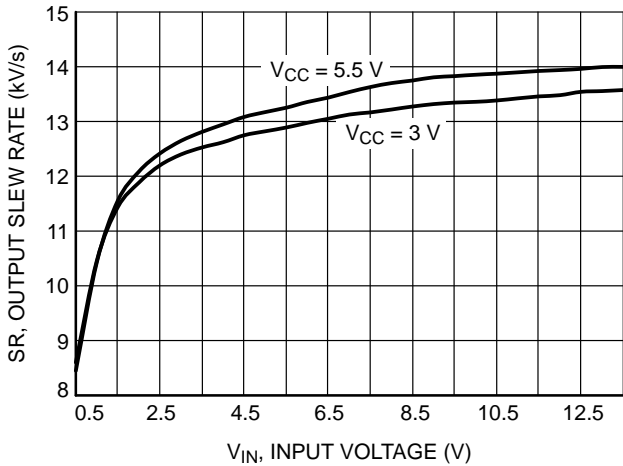

Figure 17. Output Slew Rate vs. Input Voltage

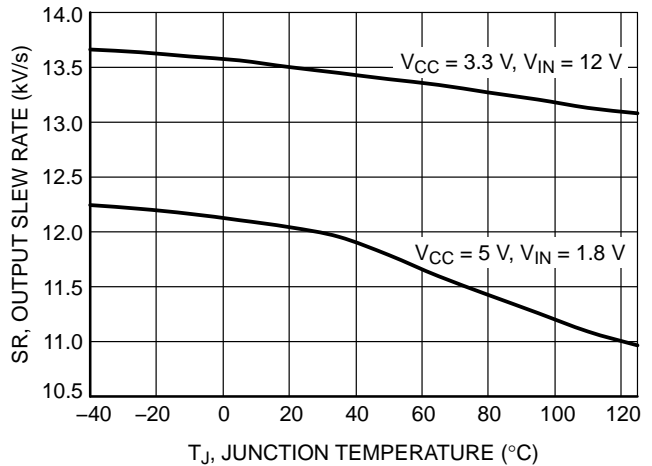

Figure 18. Output Slew Rate vs. Temperature

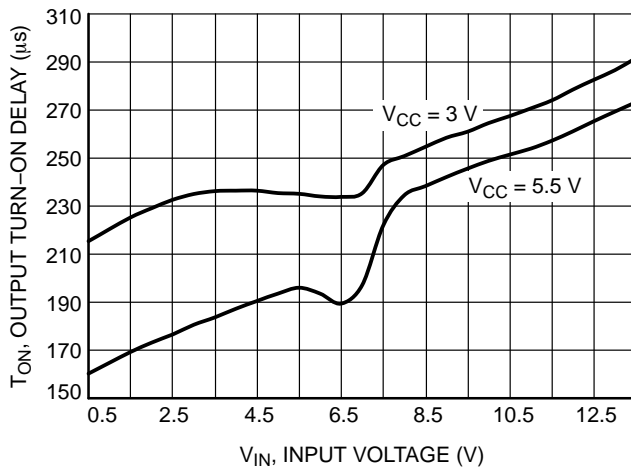

Figure 19. Output Turn-on Delay vs. Input Voltage

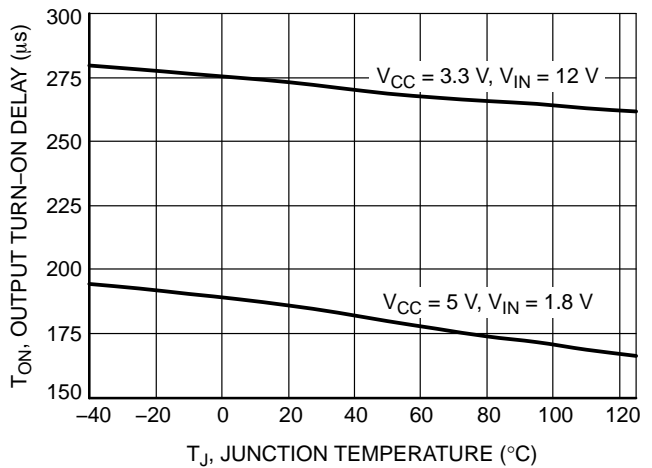

Figure 20. Output Turn-on Delay vs. Temperature

NCP45524, NCP45525

TYPICAL CHARACTERISTICS

($T_J = 25^\circ\text{C}$ unless otherwise specified)

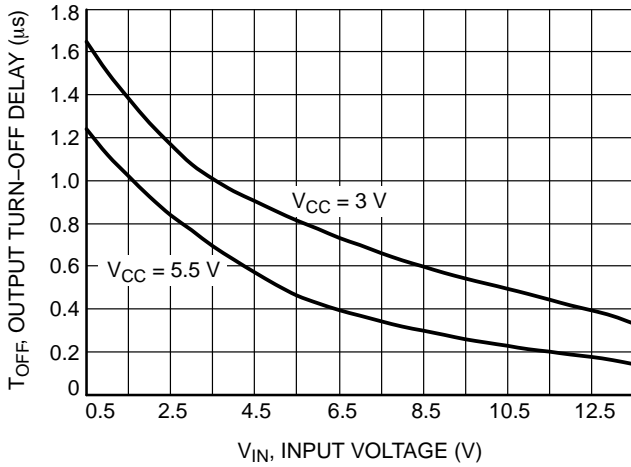

Figure 21. Output Turn-off Delay vs. Input Voltage

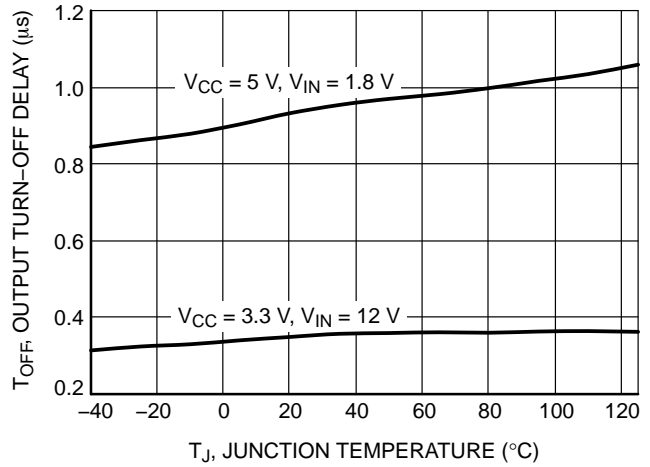

Figure 22. Output Turn-off Delay vs. Temperature

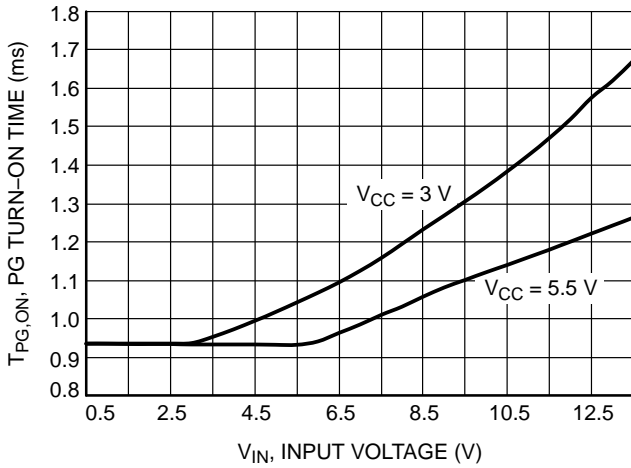

Figure 23. Power Good Turn-on Time vs. Input Voltage

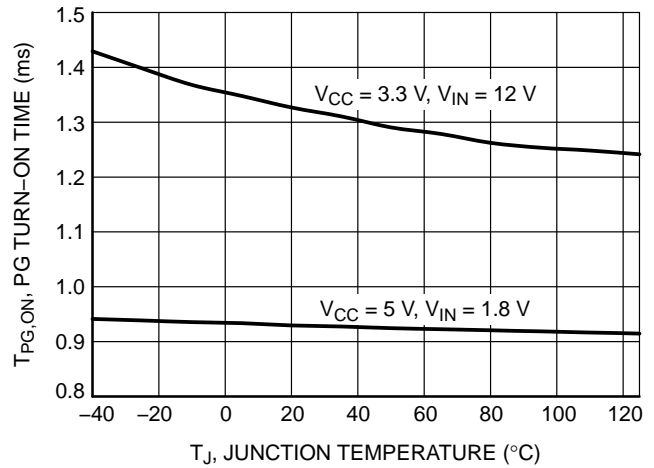

Figure 24. Power Good Turn-on Time vs. Temperature

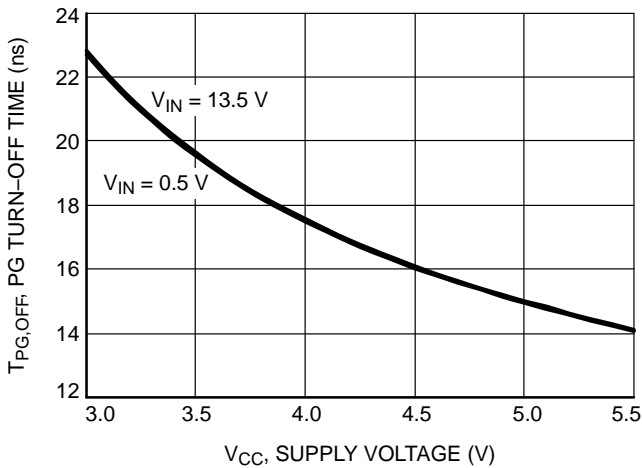

Figure 25. Power Good Turn-off Time vs. Supply Voltage

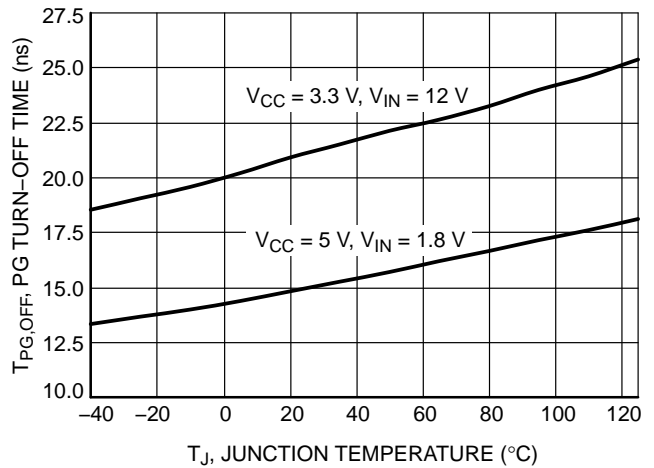

Figure 26. Power Good Turn-off Time vs. Temperature

NCP45524, NCP45525

TYPICAL CHARACTERISTICS

($T_J = 25^\circ\text{C}$ unless otherwise specified)

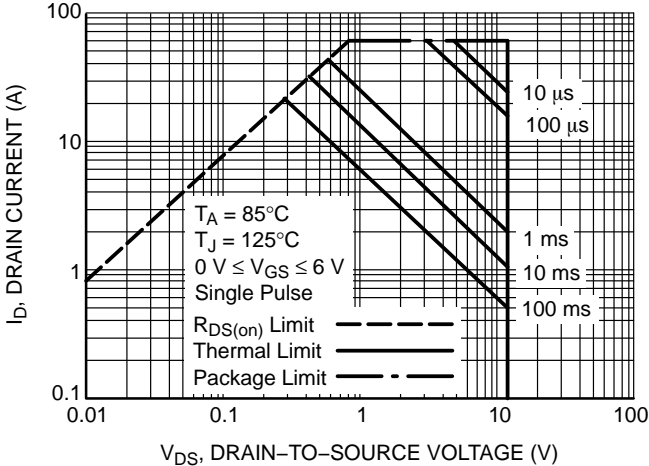

Figure 27. Maximum Rated Forward Biased Safe Operating Area

APPLICATIONS INFORMATION

Enable Control

Both the NCP45524 and the NCP45525 have two part numbers, NCP4552x-H and NCP4552x-L, that only differ in the polarity of the enable control.

The NCP4552x-H devices allow for enabling the MOSFET in an active-high configuration. When the V_{CC} supply pin has an adequate voltage applied and the EN pin is at a logic high level, the MOSFET will be enabled. Similarly, when the EN pin is at a logic low level, the MOSFET will be disabled. An internal pull down resistor to ground on the EN pin ensures that the MOSFET will be disabled when not being driven.

The NCP4552x-L devices allow for enabling the MOSFET in an active-low configuration. When the V_{CC} supply pin has an adequate voltage applied and the EN pin is at a logic low level, the MOSFET will be enabled. Similarly, when the EN pin is at a logic high level, the MOSFET will be disabled. An internal pull up resistor to V_{CC} on the EN pin ensures that the MOSFET will be disabled when not being driven.

Power Sequencing

The NCP4552x devices will function with any power sequence, but the output turn-on delay performance may vary from what is specified. To achieve the specified performance, there are two recommended power sequences:

- 1) $V_{CC} \rightarrow V_{IN} \rightarrow V_{EN}$
- 2) $V_{IN} \rightarrow V_{CC} \rightarrow V_{EN}$

V_{CC} must be at 2 V or higher when EN is asserted to ensure that the enable is latched properly for correct operation. If EN comes up before V_{CC} reaches 2 V, then the EN may not take effect.

Load Bleed (Quick Discharge)

The NCP4552x devices have an internal bleed resistor, R_{BLEED} , which is used to bleed the charge off of the load to ground after the MOSFET has been disabled. In series with the bleed resistor is a bleed switch that is enabled whenever the MOSFET is disabled. The MOSFET and the bleed switch are never concurrently active.

Is it required that the BLEED pin be connected to V_{OUT} either directly (as shown in Figures 29 and 32) or through an external resistor, R_{EXT} (as shown in Figures 28 and 31). R_{EXT} should not exceed 100 M Ω and can be used to increase the total bleed resistance and decrease the load bleed rate.

Care must be taken to ensure that the power dissipated across R_{BLEED} is kept at a safe level. The maximum continuous power that can be dissipated across R_{BLEED} is 0.4 W. R_{EXT} can be used to decrease the amount of power dissipated across R_{BLEED} .

Power Good

The NCP45524 devices have a power good output (PG) that can be used to indicate when the gate of the MOSFET is fully charged. The PG pin is an active-high, open-drain output that requires an external pull up resistor, R_{PG} , greater

than or equal to 1 k Ω to an external voltage source, V_{TERM} , that is compatible with input levels of all devices connected to this pin (as shown in Figures 28 and 29).

The power good output can be used as the enable signal for other active-high devices in the system (as shown in Figure 30). This allows for guaranteed by design power sequencing and reduces the number of enable signals needed from the system controller. If the power good feature is not used in the application, the PG pin should be tied to GND.

Slew Rate Control

The NCP4552x devices are equipped with controlled output slew rate which provides soft start functionality. This limits the inrush current caused by capacitor charging and enables these devices to be used in hot swap applications.

The slew rate of the NCP45525 can be decreased with an external capacitor added between the SR pin and ground (as shown in Figures 31 and 32). With an external capacitor present, the slew rate can be determined by the following equation:

$$\text{Slew Rate} = \frac{K_{SR}}{C_{SR}} \text{ [V/s]} \quad (\text{eq. 1})$$

where K_{SR} is the specified slew rate control constant, found in Table 4, and C_{SR} is the slew rate control capacitor added between the SR pin and ground. The slew rate of the device will always be the lower of the default slew rate and the adjusted slew rate. Therefore, if the C_{SR} is not large enough to decrease the slew rate more than the specified default value, the slew rate of the device will be the default value. The SR pin can be left floating if the slew rate does not need to be decreased.

Capacitive Load

The peak in-rush current associated with the initial charging of the application load capacitance needs to stay below the specified I_{MAX} . CL (capacitive load) should be less than C_{max} as defined by the following equation:

$$C_{max} = \frac{I_{max}}{SR_{typ}} \quad (\text{eq. 2})$$

Where I_{MAX} is the maximum load current, and SR_{typ} is the typical default slew rate when no external load capacitor is added to the SR pin.

OFF to ON Transition Energy Dissipation

The energy dissipation due to load current traveling from V_{IN} to V_{OUT} is very low during steady state operation due to the low R_{ON} . When the EN signal is asserted high, the load switch transitions from an OFF state to an ON state. During this time, the resistance from V_{IN} to V_{OUT} transitions from high impedance to R_{ON} , and additional energy is dissipated in the device for a short period of time. The worst case energy dissipated during the OFF to ON transition can be approximated by the following equation:

NCP45524, NCP45525

$$E = 0.5 \cdot V_{IN} \cdot (I_{INRUSH} + 0.8 \cdot I_{LOAD}) \cdot dt \quad (\text{eq. 3})$$

Where V_{IN} is the voltage on the V_{IN} pin, I_{INRUSH} is the inrush current caused by capacitive loading on V_{OUT} , and dt is the time it takes V_{OUT} to rise from 0 V to V_{IN} . I_{INRUSH} can be calculated using the following equation:

$$I_{INRUSH} = \frac{dv}{dt} \cdot C_L \quad (\text{eq. 4})$$

Where dv/dt is the programmed slew rate, and C_L is the capacitive loading on V_{OUT} . To prevent thermal lockout or damage to the device, the energy dissipated during the OFF to ON transition should be limited to E_{TRANS} listed in operating ranges table.

ecoSWITCH LAYOUT GUIDELINES

Electrical Layout Considerations

Correct physical PCB layout is important for proper low noise accurate operation of all ecoSWITCH products.

Power Planes: The ecoSWITCH is optimized for extremely low R_{on} resistance, however, improper PCB layout can substantially increase source to load series resistance by adding PCB board parasitic resistance. Solid connections to the V_{IN} and V_{OUT} pins of the ecoSWITCH to copper planes should be used to achieve low series resistance and good thermal dissipation. The ecoSWITCH requires ample heat dissipation for correct thermal lockout operation. The internal FET dissipates load condition dependent amounts of power in the milliseconds following the rising edge of enable, and providing good thermal conduction from the packaging to the board is critical. Direct coupling of V_{IN} to V_{OUT} should be avoided, as this will adversely affect slew rates. The figure below shows an example of correct power plane layout. The number and location of pins for specific ecoSWITCH products may vary. This demonstrates large planes for both V_{IN} and V_{OUT} , while avoiding capacitive coupling between the two planes.

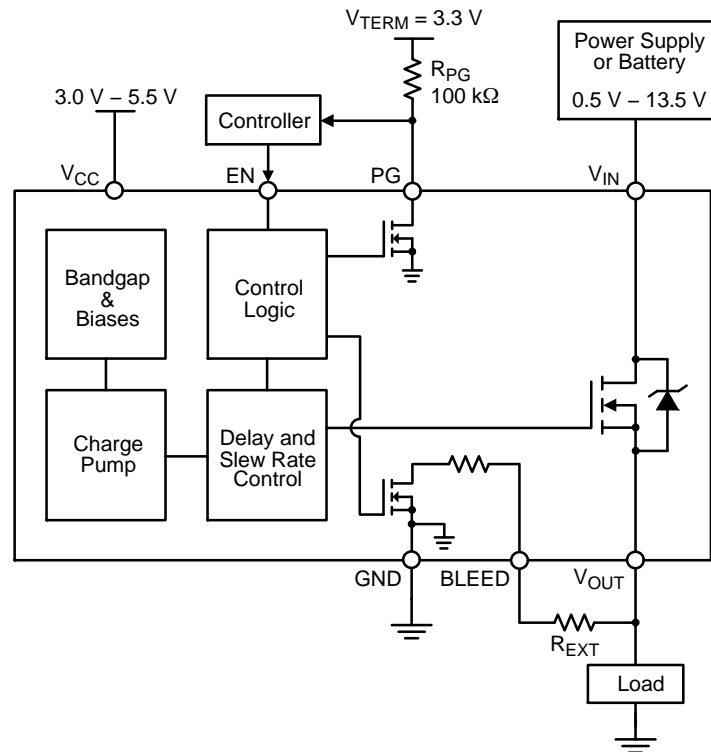

Figure 28. NCP45524 Typical Application Diagram – Load Switch

NCP45524, NCP45525

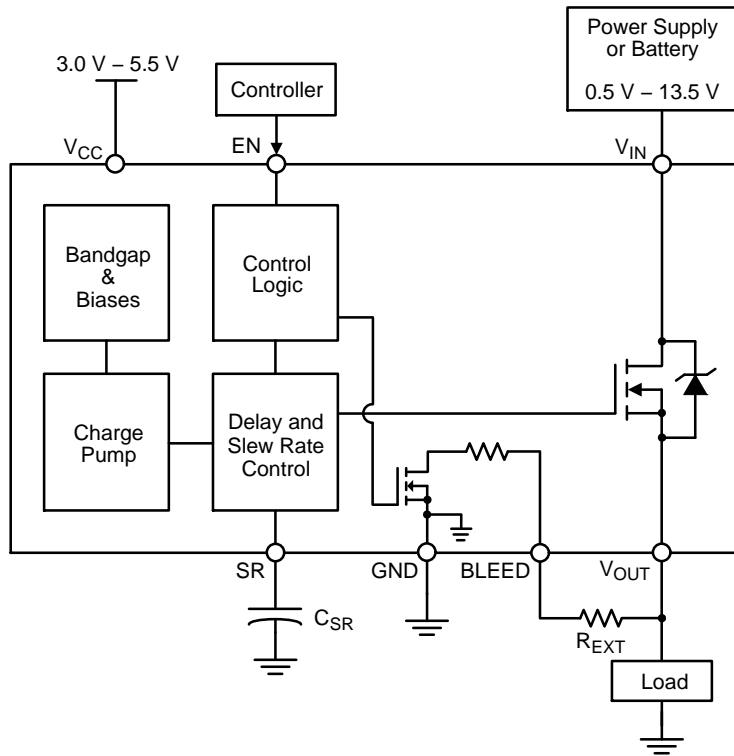

Figure 31. NCP45525 Typical Application Diagram – Load Switch

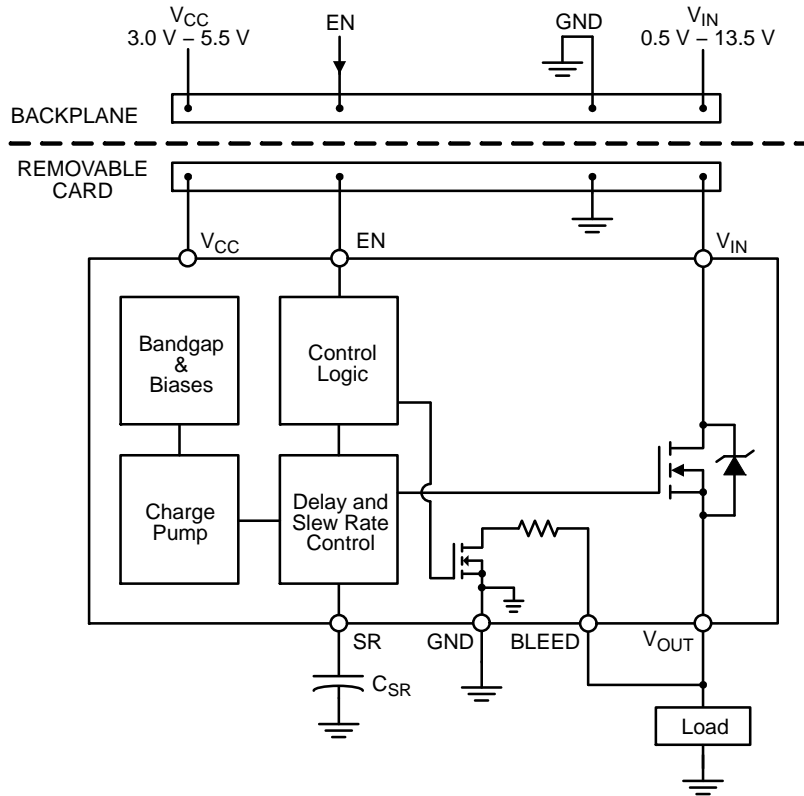

Figure 32. NCP45525 Typical Application Diagram – Hot Swap

NCP45524, NCP45525

ORDERING INFORMATION

| Device | Pin 6 Functionality | EN Polarity | Package | Shipping† |
|------------------|---------------------|-------------|-------------------|--------------------|
| NCP45524IMNTWG-H | PG | Active-High | DFN8 (Pb-Free) | 3000 / Tape & Reel |
| NCP45524IMNTWG-L | PG | Active-Low | | |
| NCP45525IMNTWG-H | SR | Active-High | | |
| NCP45525IMNTWG-L | SR | Active-Low | | |

†For information on tape and reel specifications, including part orientation and tape sizes, please refer to our Tape and Reel Packaging Specifications Brochure, BRD8011/D.

MECHANICAL CASE OUTLINE

PACKAGE DIMENSIONS

ON Semiconductor®



SCALE 2:1

DFN8 2x2, 0.5P
CASE 506CC
ISSUE A

DATE 24 JUN 2014

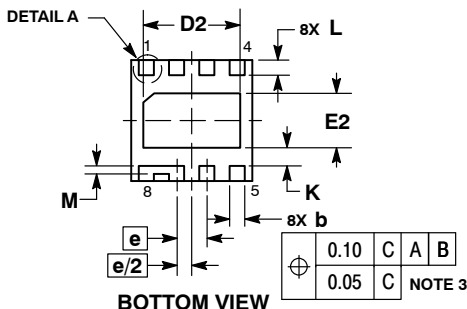
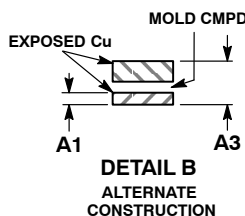
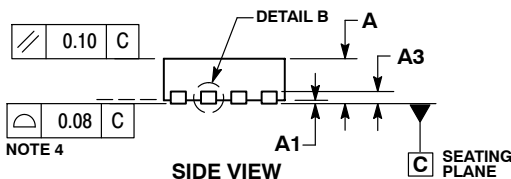
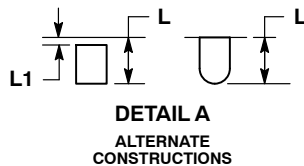
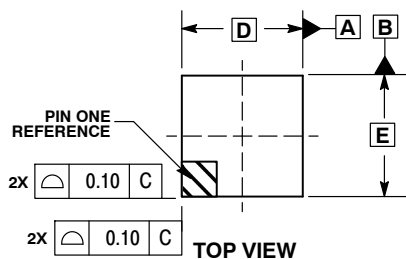

NOTES:

1. DIMENSIONING AND TOLERANCING PER ASME Y14.5M, 1994.
2. CONTROLLING DIMENSION: MILLIMETERS.
3. DIMENSION b APPLIES TO PLATED TERMINAL AND IS MEASURED BETWEEN 0.15 AND 0.30 MM FROM TERMINAL TIP. COPLANARITY APPLIES TO THE EXPOSED PAD AS WELL AS THE TERMINALS.
4. COPLANARITY APPLIES TO THE EXPOSED PAD AS WELL AS THE TERMINALS.

| MILLIMETERS | | |
|-------------|----------|------|
| DIM | MIN | MAX |
| A | 0.80 | 1.00 |
| A1 | 0.00 | 0.05 |
| A3 | 0.20 REF | |
| b | 0.20 | 0.30 |
| D | 2.00 BSC | |
| D2 | 1.50 | 1.70 |
| E | 2.00 BSC | |
| E2 | 0.80 | 1.00 |
| e | 0.50 BSC | |
| K | 0.20 REF | |
| L | 0.18 | 0.38 |
| L1 | --- | 0.15 |
| M | 0.14 REF | |

GENERIC MARKING DIAGRAM*

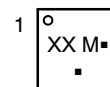

- XX = Specific Device Code
- M = Date Code
- = Pb-Free Package

(Note: Microdot may be in either location)
*This information is generic. Please refer to device data sheet for actual part marking. Pb-Free indicator, "G" or microdot "▪", may or may not be present.

RECOMMENDED SOLDERING FOOTPRINT*

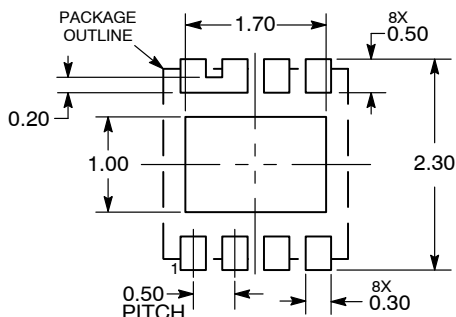

DIMENSIONS: MILLIMETERS

*For additional information on our Pb-Free strategy and soldering details, please download the ON Semiconductor Soldering and Mounting Techniques Reference Manual, SOLDERRM/D.

| | | |
|------------------|----------------|--|
| DOCUMENT NUMBER: | 98AON67172E | Electronic versions are uncontrolled except when accessed directly from the Document Repository. Printed versions are uncontrolled except when stamped "CONTROLLED COPY" in red. |
| DESCRIPTION: | DFN8 2X2, 0.5P | PAGE 1 OF 1 |

ON Semiconductor and ON are trademarks of Semiconductor Components Industries, LLC dba ON Semiconductor or its subsidiaries in the United States and/or other countries. ON Semiconductor reserves the right to make changes without further notice to any products herein. ON Semiconductor makes no warranty, representation or guarantee regarding the suitability of its products for any particular purpose, nor does ON Semiconductor assume any liability arising out of the application or use of any product or circuit, and specifically disclaims any and all liability, including without limitation special, consequential or incidental damages. ON Semiconductor does not convey any license under its patent rights nor the rights of others.

onsemi, **Onsemi**, and other names, marks, and brands are registered and/or common law trademarks of Semiconductor Components Industries, LLC dba "**onsemi**" or its affiliates and/or subsidiaries in the United States and/or other countries. **onsemi** owns the rights to a number of patents, trademarks, copyrights, trade secrets, and other intellectual property. A listing of **onsemi**'s product/patent coverage may be accessed at www.onsemi.com/site/pdf/Patent-Marking.pdf. **onsemi** reserves the right to make changes at any time to any products or information herein, without notice. The information herein is provided "as-is" and **onsemi** makes no warranty, representation or guarantee regarding the accuracy of the information, product features, availability, functionality, or suitability of its products for any particular purpose, nor does **onsemi** assume any liability arising out of the application or use of any product or circuit, and specifically disclaims any and all liability, including without limitation special, consequential or incidental damages. Buyer is responsible for its products and applications using **onsemi** products, including compliance with all laws, regulations and safety requirements or standards, regardless of any support or applications information provided by **onsemi**. "Typical" parameters which may be provided in **onsemi** data sheets and/or specifications can and do vary in different applications and actual performance may vary over time. All operating parameters, including "Typicals" must be validated for each customer application by customer's technical experts. **onsemi** does not convey any license under any of its intellectual property rights nor the rights of others. **onsemi** products are not designed, intended, or authorized for use as a critical component in life support systems or any FDA Class 3 medical devices or medical devices with a same or similar classification in a foreign jurisdiction or any devices intended for implantation in the human body. Should Buyer purchase or use **onsemi** products for any such unintended or unauthorized application, Buyer shall indemnify and hold **onsemi** and its officers, employees, subsidiaries, affiliates, and distributors harmless against all claims, costs, damages, and expenses, and reasonable attorney fees arising out of, directly or indirectly, any claim of personal injury or death associated with such unintended or unauthorized use, even if such claim alleges that **onsemi** was negligent regarding the design or manufacture of the part. **onsemi** is an Equal Opportunity/Affirmative Action Employer. This literature is subject to all applicable copyright laws and is not for resale in any manner.

ADDITIONAL INFORMATION

TECHNICAL PUBLICATIONS:

Technical Library: www.onsemi.com/design/resources/technical-documentation
onsemi Website: www.onsemi.com

ONLINE SUPPORT: www.onsemi.com/support

For additional information, please contact your local Sales Representative at www.onsemi.com/support/sales