

© COPYRIGHT 1976 BY AMP INCORPORATED, HARRISBURG, PA. ALL INTERESTS RESERVED. AMP INCORPORATED PRODUCTS COVERED BY U.S. AND FOREIGN PATENTS AND/OR PATENTS PENDING. UNPUBLISHED INFORMATION REPRODUCED WITHOUT PERMISSION OF AMP INCORPORATED.

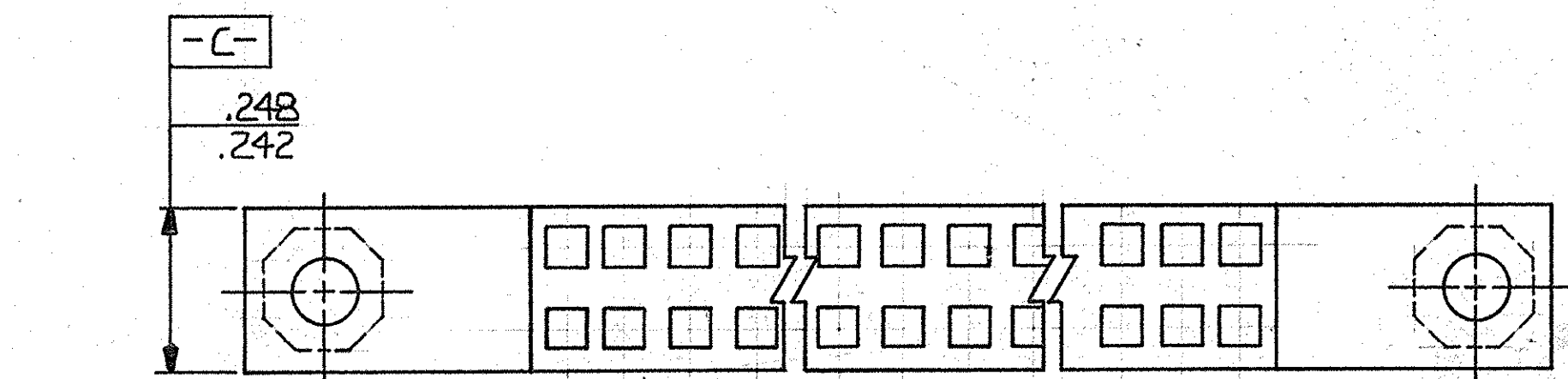
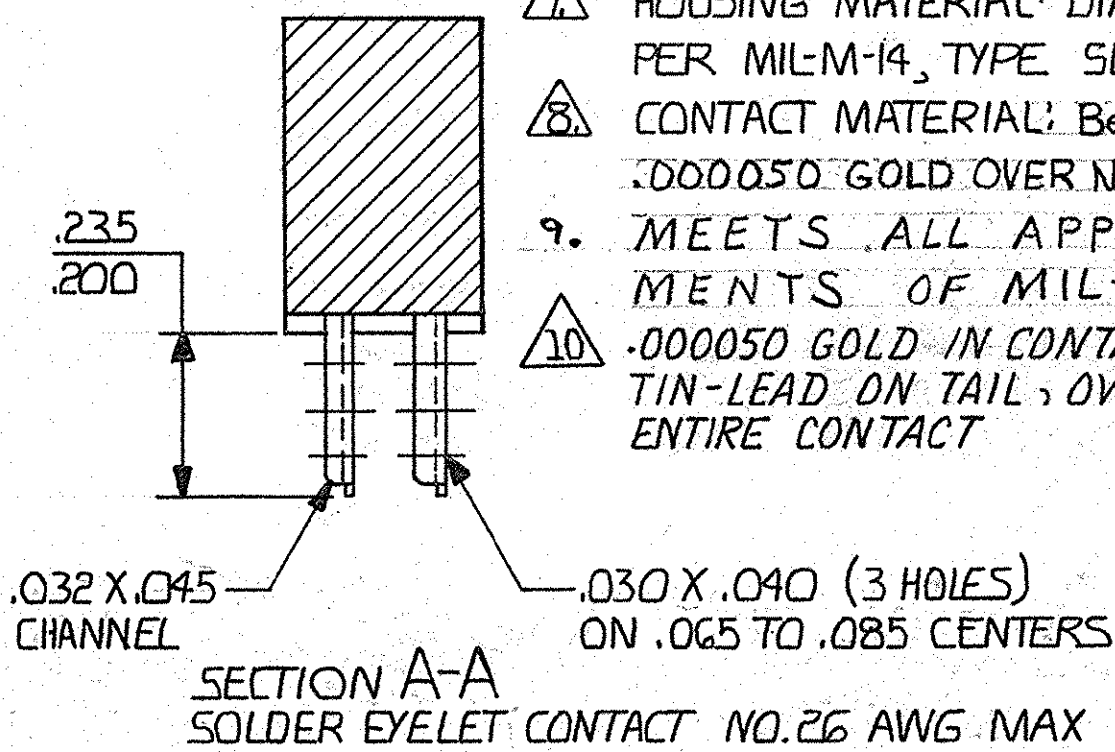
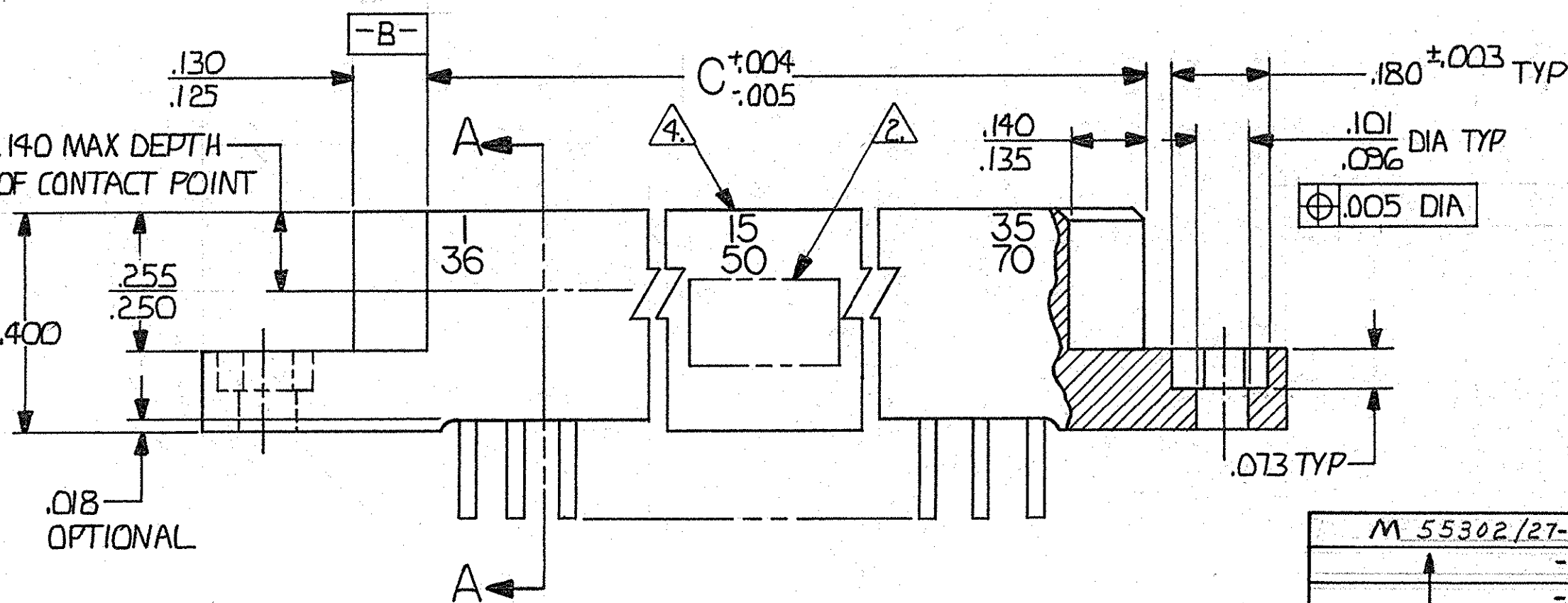
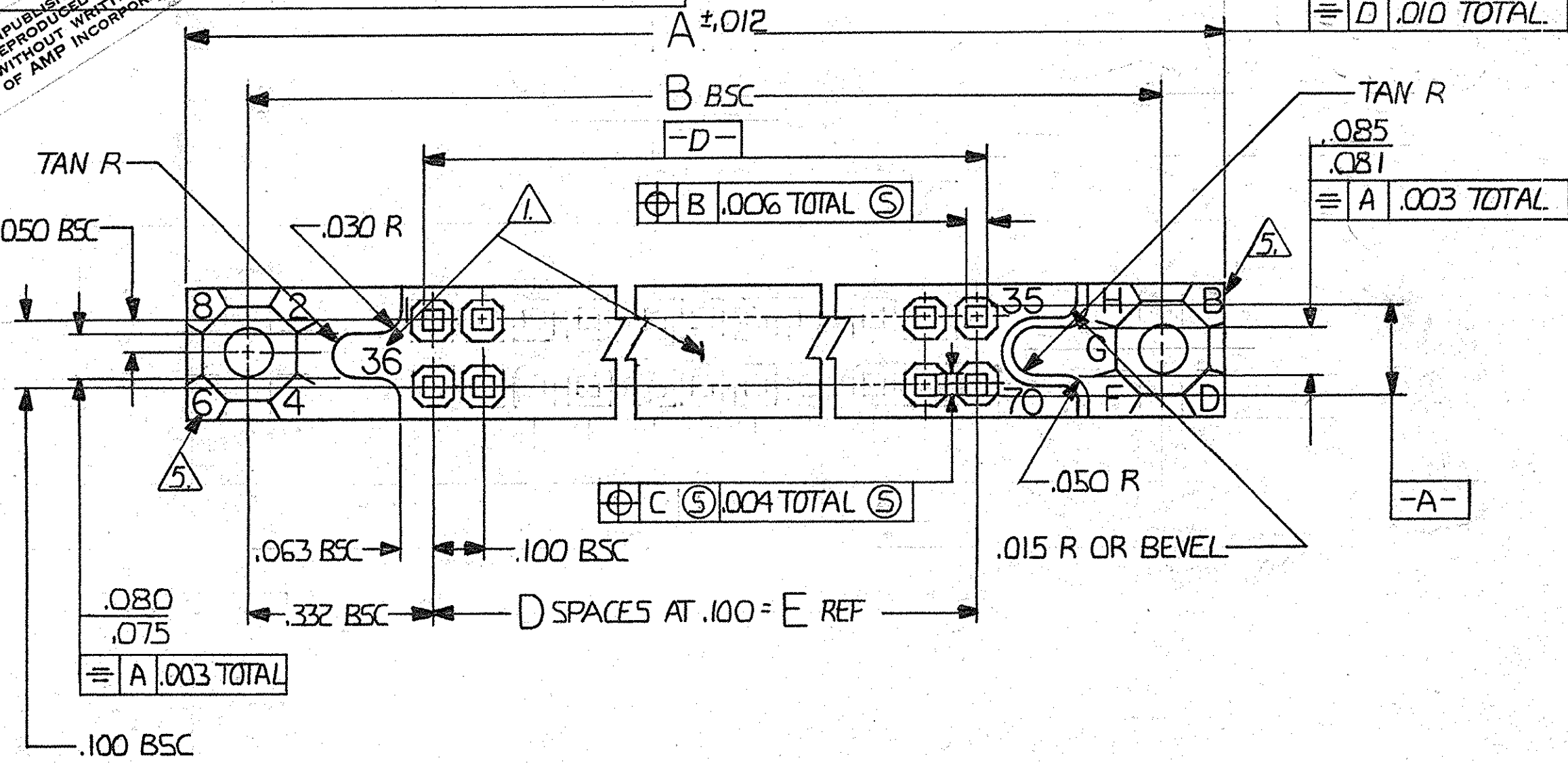

REVISIONS						
P.	F.	ZONE	LTR	DESCRIPTION	DATE	APPROVED
✓		D		RELEASED WAS 5087-940-1 RW	6-14-76	
✓		01		REVISED PER ECN 4977 m.s.	11-16-76	
✓		02		REVISED 5061 m.s.	2-2-77	
✓		03		ADDED 4 P/N SHT. 2 6148 m.s.	7-30-79	
✓		04		MIL. P/N'S ASSIGNED	4-80	DLK Ro
✓		05		REVISED PER ECN 8248 m	12-82	DJM
✓		A		REV. PER ECN AB-0535	db 12-84	EAM
✓		B		REV PER DF-2240	T.W. 10-89	ASR
✓		C		REV PER DOW-5859-96	TT 04-98	982
✓		D		REV PER ECO-05-013228	11-05	PY

- 1. NUMBERS AND LINES INDICATING EVERY FIVE CAVITIES MOLDED OR MARKED ON MATING FACE.
- 2. "AMP", 00779, PART NO., MILITARY PART NO. AND DATE CODE (SIDE OPTIONAL).
- 3. MUST MEET ALL APPLICABLE REQUIREMENTS OF MIL-C-55302.
- 4. NUMBERS INDICATING EVERY FIVE CAVITIES MOLDED OR MARKED ON SIDE.
- 5. KEY POSITION IDENTIFICATION MOLDED ON SURFACES SHOWN.
- 6. USE EXTERNAL KEY NUMBER 530341-1 MATES WITH PART NUMBER 530339.
- 7. HOUSING MATERIAL: DIALYL PHTHALATE, COLOR: BLUE PER MIL-M-14, TYPE SDG-F.
- 8. CONTACT MATERIAL: BeCu OR COPPER-NICKEL-SILICONE .000050 GOLD OVER NICKEL, TIN-LEAD ON TAILS
- 9. MEETS ALL APPLICABLE REQUIREMENTS OF MIL-C-55302.
- 10. .000050 GOLD IN CONTACT AREA, .000100 TIN-LEAD ON TAIL, OVER .000050 NICKEL ENTIRE CONTACT

M 55302/27-108	56	55	5.400	54	5.655	6.065	6.355	110	530758-9
-107	51	50	4.900	49	5.165	5.565	5.855	100	-8
-106	46	45	4.400	44	4.665	5.065	5.355	90	-7
-105	41	40	3.900	39	4.165	4.565	4.855	80	-6
-104	36	35	3.400	34	3.665	4.065	4.355	70	-5
-103	31	30	2.900	29	3.165	3.565	3.855	60	-4
-102	26	25	2.400	24	2.665	3.065	3.355	50	-3
-101	21	20	1.900	19	2.165	2.565	2.855	40	-2
M 55302/27-100	16	15	1.400	14	1.665	2.065	2.355	30	530758-1

UNLESS OTHERWISE SPECIFIED DIMENSIONS ARE IN INCHES. TOLERANCES ON: DECIMALS ±.005 ANGLES ±.005	CONTRACT NO		AMP INCORPORATED Harrisburg, Pa.	
	MATERIAL			
FINISH RCPT. CONTACT:	DR. Robert Weber 6-14-76	NAME BOX CONNECTOR RECEPTACLE ASSY, 100 GRID, EXTERNAL KEYING		
	CHY. [Signature] 6-15-76	SIZE CODE IDENT NO DRAWING NO		
OTHER APPD	APPD. R. Williams 6-16-76	C 00779 530758		
	APPD. R. Shawman 6-16-76	SCALE 4-1 SHEET 1 OF 2		

© COPYRIGHT 19 BY AMP INCORPORATED, HARRISBURG, PA.  
 ALL INTERNATIONAL RIGHTS RESERVED. AMP INCORPORATED PRODUCTS  
 COVERED BY U. S. AND FOREIGN PATENTS AND/OR PATENTS PENDING.

REVISIONS			
P	F	ZONE	DATE
✓	✓	D	7/2/79

DESCRIPTION: SEE SHEET 1 OF 2

530758

MILITARY PART NO.	CAVITY IDENT. NO.	E	D	C	B	A	NO. OF CONTACTS	PART NO.
M55302/27-197	71 70 140	6.900	69	7.165	7.565	7.855	140	1-530758-3
M55302/27-196	68 67 134	6.600	66	6.865	7.265	7.555	134	1-530758-2
M55302/27-195	66 65 130	6.400	64	6.665	7.065	7.355	130	1-530758-1
M55302/27-194	61 60 120	5.900	59	6.165	6.565	6.855	120	1-530758-0

UNLESS OTHERWISE SPECIFIED DIMENSIONS ARE IN INCHES. TOLERANCES ON: DECIMALS ±.005 ANGLES ±	CONTRACT NO 7-30-79		<b>AMP</b>   AMP INCORPORATED Harrisburg, Pa.		
	DR <i>M. Smith</i>	CHK <i>Royce Durb...</i>			NAME
	MATERIAL	APPR <i>Royce Durb...</i>	APPR <i>John Kaufman</i>	SIZE	C 00779
	FINISH	DSGN APPD	OTHER APPD	CODE IDENT NO	530758
			SCALE	SHEET 2 OF 2	