

Distributed by:

JAMECO[®]
ELECTRONICS

www.Jameco.com ♦ 1-800-831-4242

The content and copyrights of the attached
material are the property of its owner.

Jameco Part Number 2036891

Modular Jack

95001 Right Angle Low Profile

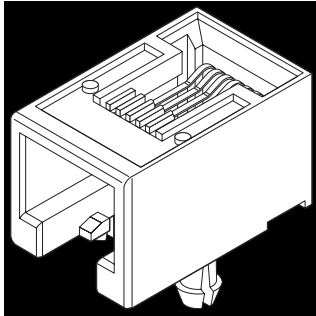

Features and Benefits

- Very low profile—about 3/4 that of industry standard
- Automatic placement possible
- Foot pattern identical to industry standard
- High reliability, square contact
- Surface Mount Compatible

Reference Information

Product Specification: PS-95001
 Packaging: Tube
 UL File No.: E107635
 Mates With: FCC 68 plugs
 Designed In: Millimeters

Electrical

Voltage: 125V
 Current: 1.5A
 Contact Resistance: 20 milliohms max.
 Dielectric Withstanding Voltage: 1000V
 Insulation Resistance: 500 Megohms min.

Physical

Housing: Gray polyamide, UL 94V-0
 Contact: Phosphor Bronze
 Plating: Post plate 1.27 to 1.52µm (50 to 60µ") Gold in contact area, 1.90µm (75µ") min. pure Tin in tail area both over Nickel overall
 Operating Temperature: -40 to +80°C

Circuits	Loaded Contacts	Order No.	Key	Lead-free
4	4	95001-6441	No	Yes
6	4	95001-6641	No	
6	6	95001-6661	No	
8	8	95001-6881	No	
8	8	95001-6882	Yes	

Modular Jack

43202 Right Angle, Low Profile Shielded and Unshielded Versions

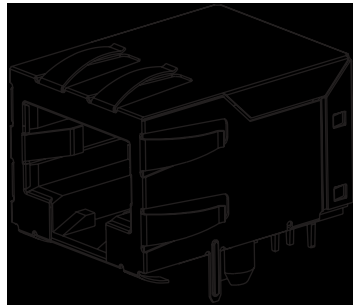

Features and Benefits

- Ultra low profile
- Enhanced panel grounding tabs on shielded RJ-45 configuration
- Enclosed top
- 100% tested for hi-pot and continuity

Reference Information

Product Specification: PS-43202-001
 Packaging: Tray
 UL File No.: E107635
 CSA File No.: LR19980
 Use with: FCC 68 Plugs
 Designed in: Inches

Electrical

Voltage: 125V
 Current: 1.5A
 Contact Resistance: 10 milliohms max.
 Dielectric Withstanding Voltage: 1000V AC
 Insulation Resistance: 500 Megohms min.

Mechanical

Durability: 500 cycles min.

Physical

Housing: Black glass-filled nylon, UL 94V-0
 Contact: Phosphor Bronze
 Plating: Contact Area—1.27µm (50µ") min. Gold
 Solder Tails—2.54µm (100µ") min. Tin, Nickel overall
 Operating Temperature: -40 to +85°C

Circuits	Loaded Contacts	Shield Panel Ground Tab Option	Order No.			Lead-free
			Unshielded	Shielded		
				Front Position PCB Ground Tab	Rear Position PCB Ground Tab	
4	2		43202-4104			Yes
	4		43202-4101			
6	2		43202-6107			
	4		43202-6104			
	6		43202-6101			
8	8		43202-8104			
		All Panel Ground Tabs	43202-8919	43202-8927		
		Offset Panel Ground Tabs	43202-8918	43202-8926		
		Top Panel Ground Tabs	43202-8917	43202-8925		
		No Panel Ground Tabs	43202-8916	43202-8924		
	10		43202-8101			
		All Panel Ground Tabs	43202-8903	43202-8911		
		Offset Panel Ground Tabs	43202-8902	43202-8910		
		Top Panel Ground Tabs	43202-8901	43202-8909		
		No Panel Ground Tabs	43202-8900	43202-8908		

Note: Visit www.molex.com for additional shield panel ground tab options



PRODUCT SPECIFICATION

ULTRA LOW PROFILE RIGHT ANGLE MODULAR JACKS

1.0 SCOPE

This Product Specification covers the 1.27 mm (.050 inch) centerline (pitch) printed circuit board (PCB) modular jack connector series with selective gold and tin plating.

2.0 PRODUCT DESCRIPTION

2.1 PRODUCT NAME AND SERIES NUMBER(S)

Ultra Low Profile Right Angle Modular Jacks 43202

2.2 DIMENSIONS, MATERIALS, PLATINGS AND MARKINGS

See the appropriate sales drawings (SDA-43202) for information on dimensions, materials, plating and markings.

2.3 SAFETY AGENCY APPROVALS

UL File Number.....E107635
CSA File Number.....LR19980

3.0 APPLICABLE DOCUMENTS AND SPECIFICATIONS

FCC Rules and Regulations, Part 68, Subpart F
REA Bulletin 345-81, PE-76; Specification for modular telephone set hardware
ANSI/EIA/TIA-568
IEC-60603-7
UL 1863
MIL-STD-202; General requirements for test specifications

4.0 RATINGS

4.1 VOLTAGE

56.5 V DC
150 V_{RMS} AC (Ringing voltage only)

4.2 CURRENT

1.5 Amps @ 25°C

4.3 TEMPERATURE

Operating: - 40°C to + 85°C
Nonoperating:* - 40°C to + 85°C
*Packaging materials should not exceed + 50°C

REVISION: C2	EGR/ECN INFORMATION: EC No: UCP2008-0143 DATE: 2007/07/23	TITLE: PRODUCT SPECIFICATION ULTRA LOW PROFILE RIGHT ANGLE MODULAR JACKS	SHEET No. 1 of 5
DOCUMENT NUMBER: PS-43202-001	CREATED / REVISED BY: JBELL 2007/07/23	CHECKED BY: LSCHMIDT 2007/07/24	APPROVED BY: FSMITH 2007/07/25



PRODUCT SPECIFICATION

5.0 PERFORMANCE

5.1 ELECTRICAL REQUIREMENTS

	DESCRIPTION	TEST CONDITION	REQUIREMENT
	Contact Resistance (Low Level)	Mate connectors: apply a maximum voltage of 20 mV and a current of 15 mA . (Measurement locations in Section 7.0)	10 milliohms MAXIMUM [initial]
	Insulation Resistance	Unmated connector, mounted to a PCB: apply a voltage of 500 VDC between adjacent terminals and between terminals to ground.	500 Megohms MINIMUM
	Dielectric Withstanding Voltage	Mate connectors: apply a voltage of 1000 VAC for 1 minute between adjacent terminals and between terminals to ground.	No breakdown; current leakage < 5 mA
	Temperature Rise	Mate connectors: measure the temperature rise at the rated current after: 96 hours	Temperature rise; +30°C MAXIMUM

REVISION: C2	EGR/ECN INFORMATION: EC No: UCP2008-0143 DATE: 2007/07/23	TITLE: PRODUCT SPECIFICATION ULTRA LOW PROFILE RIGHT ANGLE MODULAR JACKS	SHEET No. 2 of 5
DOCUMENT NUMBER: PS-43202-001	CREATED / REVISED BY: JBELL 2007/07/23	CHECKED BY: LSCHMIDT 2007/07/24	APPROVED BY: FSMITH 2007/07/25



PRODUCT SPECIFICATION

5.2 MECHANICAL REQUIREMENTS

	DESCRIPTION	TEST CONDITION	REQUIREMENT
	Connector Mate Force	Mate connector at a rate of 25 ± 6 mm (1 ± ¼ inch) per minute. (Gage dimensions in Section 7.0)	22 N (5 lbf) MAXIMUM insertion force
	Durability	Mate connectors up to 500 cycles at a maximum rate of 20 cycles per minute prior to Environmental Tests.	10 milliohms MAXIMUM (change from initial)
	Vibration (Random)	Mate connectors and vibrate per MIL-STD-202	10 milliohms MAXIMUM (change from initial) & Discontinuity < 1 microsecond
	Plug Retention Force	Apply an axial pullout force on the plug at a rate of 25 ± 6 mm (1 ± ¼ inch) per minute.	89 N (20 lbf) MINIMUM retention force
	PCB Separation Forces	Apply a perpendicular load on the plug at a rate of 25 ± 6 mm (1 ± ¼ inch) per minute.	4.5 N (1 lbf) MINIMUM withdrawal force before solder reflow 89 N (20 lbf) MINIMUM withdrawal force after solder reflow

REVISION: C2	EGR/ECN INFORMATION: EC No: UCP2008-0143 DATE: 2007/07/23	TITLE: PRODUCT SPECIFICATION ULTRA LOW PROFILE RIGHT ANGLE MODULAR JACKS	SHEET No. 3 of 5
DOCUMENT NUMBER: PS-43202-001	CREATED / REVISED BY: JBELL 2007/07/23	CHECKED BY: LSCHMIDT 2007/07/24	APPROVED BY: FSMITH 2007/07/25



PRODUCT SPECIFICATION

5.3 ENVIRONMENTAL REQUIREMENTS

DESCRIPTION	TEST CONDITION	REQUIREMENT												
Thermal (Cycling)	Connectors to be placed in 95% relative humidity. Maximum temperature change is 15°C/hour. Cycle linearly per chart below. Mate connectors; expose to 10 cycles of: <table border="1"> <thead> <tr> <th>Temperature °C</th> <th>Duration (Minutes)</th> </tr> </thead> <tbody> <tr> <td>30 to 5</td> <td>120</td> </tr> <tr> <td>5 to 30</td> <td>120</td> </tr> <tr> <td>Hold at 30</td> <td>240</td> </tr> <tr> <td>30 to 5</td> <td>180</td> </tr> <tr> <td>Hold at 5</td> <td>180</td> </tr> </tbody> </table>	Temperature °C	Duration (Minutes)	30 to 5	120	5 to 30	120	Hold at 30	240	30 to 5	180	Hold at 5	180	10 milliohms MAXIMUM (change from initial) & Dielectric Withstanding Voltage: No Breakdown at 500 VAC & Insulation Resistance: 500 Megohms MINIMUM & Visual: No Damage
Temperature °C	Duration (Minutes)													
30 to 5	120													
5 to 30	120													
Hold at 30	240													
30 to 5	180													
Hold at 5	180													
Solderability	Dip solder tails in flux and immerse in solder bath at 260±5°C for 5±0.5 seconds.	Solder Wetting Visual: 95% of immersed area must shown no voids, pin holes												
Resistance to Soldering Heat	Dip solder tails in molten solder and immerse in solder bath at 260±5°C for 5±0.5 seconds.	Visual: No Damage												

REVISION: C2	EGR/ECN INFORMATION: EC No: UCP2008-0143 DATE: 2007/07/23	TITLE: PRODUCT SPECIFICATION ULTRA LOW PROFILE RIGHT ANGLE MODULAR JACKS	SHEET No. 4 of 5
DOCUMENT NUMBER: PS-43202-001	CREATED / REVISED BY: JBELL 2007/07/23	CHECKED BY: LSCHMIDT 2007/07/24	APPROVED BY: FSMITH 2007/07/25



PRODUCT SPECIFICATION

6.0 PACKAGING

Parts shall be packaged to protect against damage during handling, transit and storage. See appropriate sales drawings on Sheet 1 for packaging descriptions.

7.0 GAGES AND FIXTURES

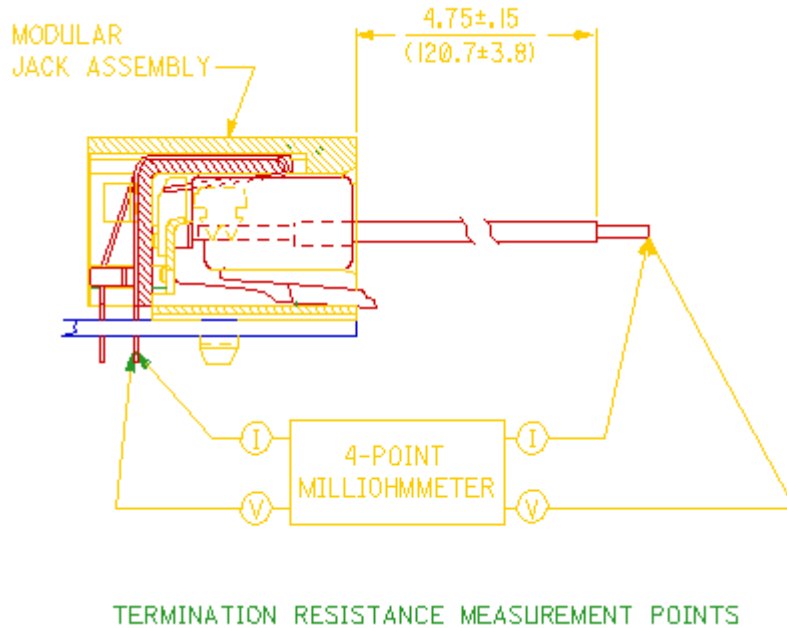

8.0 OTHER INFORMATION

REVISION: C2	EGR/ECN INFORMATION: EC No: UCP2008-0143 DATE: 2007/07/23	TITLE: PRODUCT SPECIFICATION ULTRA LOW PROFILE RIGHT ANGLE MODULAR JACKS	SHEET No. 5 of 5
DOCUMENT NUMBER: PS-43202-001	CREATED / REVISED BY: JBELL 2007/07/23	CHECKED BY: LSCHMIDT 2007/07/24	APPROVED BY: FSMITH 2007/07/25

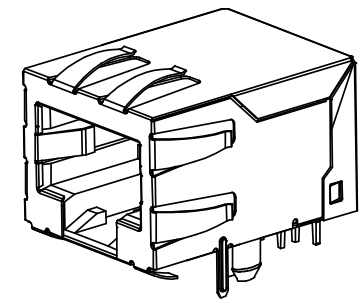

SHIELDED MODULAR JACK SHOWN WITH PANEL GROUND OPTION 'D' AND FRONT PCB GROUND TABS.

NOTES:

- 1) MATERIAL:
 HOUSING: NYLON(PA), GLASS FILLED, UL94V-0, COLOR: SEE SHEETS 5 AND 6
 INSULATOR: NYLON(PA), GLASS FILLED, UL94V-0, COLOR: SEE SHEETS 5 AND 6
 TERMINALS: PHOSPHOR BRONZE, .012/ 0.30 THICK
 SHIELD: BRASS, .007/ 0.18 THICK
- 2) FINISH:
 TERMINALS:
 A = SELECT GOLD IN CONTACT AREA: 50 MICROINCHES / 1.27 MICROMETERS MIN.,
 *SELECT TIN IN PC TAIL AREA: 100 MICROINCHES / 2.54 MICROMETERS MIN.,
 WITH OVERALL NICKEL UNDERPLATE: 50 MICROINCHES / 1.27 MICROMETERS MIN.
 B = SELECT GOLD IN CONTACT AREA: 30 MICROINCHES / 0.76 MICROMETERS MIN.,
 *SELECT TIN IN PC TAIL AREA: 100 MICROINCHES / 2.54 MICROMETERS MIN.,
 WITH OVERALL NICKEL UNDERPLATE: 50 MICROINCHES / 1.27 MICROMETERS MIN.
 *THE PRIMARY SHIPPING CARTON WILL BE LABELED "COMPLIANT TO RoHS DIRECTIVE 2002/95/EC AND ELV ANNEX II OF DIRECTIVE 2000/53/EC".
 CARTONS WITHOUT THIS LABEL MAY CONTAIN PRODUCT WITH TIN-LEAD IN THE PC TAILS AND/OR SHIELD.
- SHIELD:
 100 MICROINCHES / 2.54 MICROMETERS NICKEL OVER 50 MICROINCHES / 1.27 MICROMETERS COPPER UNDERPLATE PCB GROUND TABS DIPPED IN TIN
- 3) PRODUCT SPECIFICATION AND PROCESSING PARAMETERS: PS-43202.
- 4) PACKAGING SPECIFICATION:
 UNSHIELDED CONNECTOR ASSEMBLIES PACKAGED IN THERMOFORMED TRAYS PER MOLEX PACKAGING SPECIFICATION PK-43202-003.
 UNSHIELDED CONNECTOR ASSEMBLIES PACKAGED IN TUBES PER MOLEX PACKAGING SPECIFICATION PK-43202-005.
 SHIELDED CONNECTOR ASSEMBLIES PACKAGED IN THERMOFORMED TRAYS PER MOLEX PACKAGING SPECIFICATION PK-43202-004.
- 5) SEE SHEETS 7 - 9 FOR P.C. BOARD LAYOUTS.
- 6) CONFORMS TO FCC REGULATION PART 68.5 FOR MODULAR JACKS.
- 7) THIS PART CONFORMS TO CLASS B REQUIREMENTS OF COSMETIC SPECIFICATION PS-45499-002.

9	L2
8	L2
7	L2
6	L4
5	L
4	K2
3	L1
2	L1
1	L4
SH	REV

DRAWING LEGEND

- SHEET 1- NOTES, DRAWING LEGEND
- SHEET 2- SHIELDED MODULAR JACK W/ BOTTOM GROUND TABS
- SHEET 3- SHIELDED MODULAR JACK W/O BOTTOM GROUND TABS
- SHEET 4- UNSHIELDED MODULAR JACK
- SHEET 5- PART NUMBER CHARTS
- SHEET 6- PART NUMBER CHARTS
- SHEET 7- FOOTPRINT LAYOUT FOR 4 POSITION HOUSING
- SHEET 8- FOOTPRINT LAYOUT FOR 6 POSITION HOUSING
- SHEET 9- FOOTPRINT LAYOUT FOR 8 POSITION HOUSING

OBS COLORED JACKS EC NO: UCP2008-1189 DRAWN:JBELL 2007/11/30 CHKD:LSCHMIDT 2008/02/20 APPR:FSM/TH 2008/03/04	DESCRIPTION	QUALITY SYMBOLS ▽=0 ▽=0	GENERAL TOLERANCES (UNLESS SPECIFIED)	DIMENSION STYLE IN/MM	SCALE 4:1	DESIGN UNITS INCH	THIRD ANGLE PROJECTION	
			mm INCH	DRAWN BY JTR	DATE 1993/03/31	TITLE ULTRA LOW PROFILE RIGHT ANGLE MODULAR JACK ASSEMBLY		
			4 PLACES ±--- ±--- 3 PLACES ±--- ±.010 2 PLACES ±0.25 ±.014 1 PLACE ±0.36 ±---	CHECKED BY JTR	DATE 1993/03/31			
			ANGULAR ±1/2°	APPROVED BY RAS	DATE 1993/03/31	MATERIAL NO. SEE SHTS 5&6	DOCUMENT NO. SDA-43202	SHEET NO. 1 OF 9
L4	REV		DRAFT WHERE APPLICABLE MUST REMAIN WITHIN DIMENSIONS	SIZE C	THIS DRAWING CONTAINS INFORMATION THAT IS PROPRIETARY TO MOLEX INCORPORATED AND SHOULD NOT BE USED WITHOUT WRITTEN PERMISSION			

UNSHIELDED MODULAR JACKS

SIZE 8, LOADED 10 SHOWN

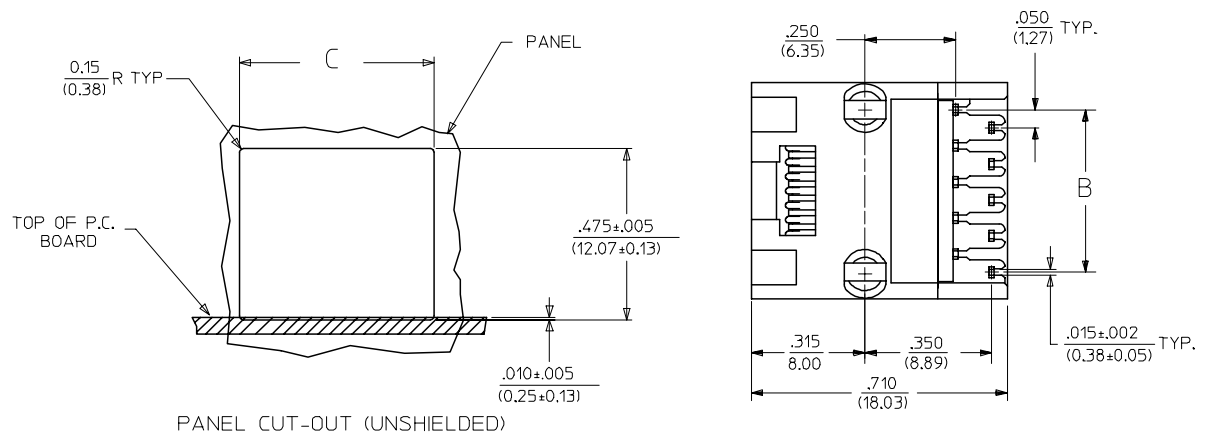
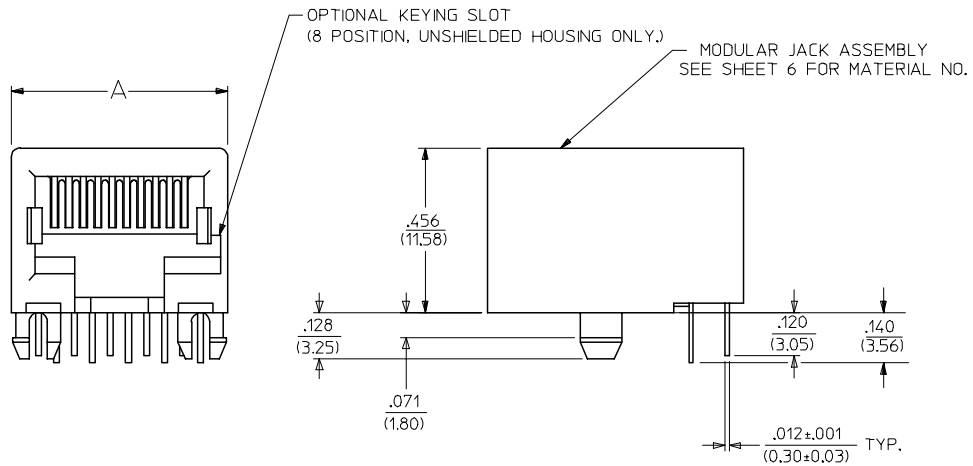

PANEL CUT-OUT (UNSHIELDED)

HOUSING SIZE	LOADED CIRCUITS	A	B	C
4	4	.440 (11.18)	.150±.005 (3.81±0.13)	.460±.005 (11.68±0.13)
4	2	.440 (11.18)	.050±.005 (1.27±0.13)	.460±.005 (11.68±0.13)
6	6	.520 (13.21)	.250±.005 (6.35±0.13)	.540±.005 (13.72±0.13)
6	4	.520 (13.21)	.150±.005 (3.81±0.13)	.540±.005 (13.72±0.13)
6	2	.520 (13.21)	.050±.005 (1.27±0.13)	.540±.005 (13.72±0.13)
8	10	.600 (15.24)	.450±.005 (11.43±0.13)	.620±.005 (15.75±0.13)
8	8	.600 (15.24)	.350±.005 (8.89±0.13)	.620±.005 (15.75±0.13)
8	6	.600 (15.24)	.250±.005 (6.35±0.13)	.620±.005 (15.75±0.13)
8	4	.600 (15.24)	.150±.005 (3.81±0.13)	.620±.005 (15.75±0.13)
8	2	.600 (15.24)	.050±.005 (1.27±0.13)	.620±.005 (15.75±0.13)



SEE SHEET ONE FC NO: UCP2004-1194 DRWN:LSCHMIDT 2004/01/02 CHKD:LSCHMIDT 2004/01/05 APPR:ESMITH 2004/01/09 K2	QUALITY SYMBOLS -0 -0	GENERAL TOLERANCES (UNLESS SPECIFIED) mm INCH 4 PLACES ± --- ± --- 3 PLACES ± --- ±.010 2 PLACES ± 0.25 ±.014 1 PLACE ± 0.36 ± --- ANGULAR ±1/2°	SCALE 4:1 DESIGN UNITS INCH DIMENSION STYLE IN/MM	THIRD ANGLE PROJECTION REVISE ON CAD ONLY
	DRAWN BY JTR DATE 1993/03/31 CHECKED BY JTR DATE 1993/03/31 APPROVED BY RAS DATE 1993/03/31	TITLE ULTRA LOW PROFILE RIGHT ANGLE MODULAR JACK ASSEMBLY		
	DRAFT WHERE APPLICABLE MUST REMAIN WITHIN DIMENSIONS	MATERIAL NO. SEE SHT 6 DOCUMENT NO. SDA-43202 SHEET NO. 4 OF 9		
	THIS DRAWING CONTAINS INFORMATION THAT IS PROPRIETARY TO MOLEX INCORPORATED AND SHOULD NOT BE USED WITHOUT WRITTEN PERMISSION			

SHIELDED MODULAR JACKS W/O BOTTOM GROUND TABS (SHEET 3)

UNSHIELDED MODULAR JACKS- (SHEET 4)

ASSEMBLY MATERIAL NUMBER	CONNECTOR SIZE	NUMBER OF CIRCUITS	SIDE/TOP PANEL GROUND TAB OPTION	PCB GROUND TAB OPTION	TERMINAL PLATING OPTION	PACKAGING	HOUSING COLOR
43202-8800	8	10	E	FRONT POSITION	A	TRAY	BLACK
43202-8801	8	10	F	FRONT POSITION	A	TRAY	
43202-8802	8	10	G	FRONT POSITION	A	TRAY	
43202-8803	8	10	H	FRONT POSITION	A	TRAY	
43202-8808	8	10	E	REAR POSITION	A	TRAY	
43202-8809	8	10	F	REAR POSITION	A	TRAY	
43202-8810	8	10	G	REAR POSITION	A	TRAY	
43202-8811	8	10	H	REAR POSITION	A	TRAY	
43202-8816	8	8	E	FRONT POSITION	A	TRAY	
43202-8817	8	8	F	FRONT POSITION	A	TRAY	
43202-8818	8	8	G	FRONT POSITION	A	TRAY	
43202-8819	8	8	H	FRONT POSITION	A	TRAY	
43202-8824	8	8	E	REAR POSITION	A	TRAY	
43202-8825	8	8	F	REAR POSITION	A	TRAY	
43202-8826	8	8	G	REAR POSITION	A	TRAY	
43202-8827	8	8	H	REAR POSITION	A	TRAY	

ASSEMBLY MATERIAL NUMBER	CONNECTOR SIZE	NUMBER OF CIRCUITS	TERMINAL PLATING OPTION	KEYING OPTION	PACKAGING OPTION	HOUSING COLOR
43202-4101	4	4	A	NO	TRAY	BLACK
43202-4104	4	2	A	NO	TRAY	
43202-6101	6	6	A	NO	TRAY	
43202-6102	6	6	B	NO	TRAY	
43202-6104	6	4	A	NO	TRAY	
43202-6105	6	4	B	NO	TRAY	
43202-6107	6	2	A	NO	TRAY	
43202-6110	6	6	B	NO	TUBE	
43202-8101	8	10	A	NO	TRAY	
43202-8104	8	8	A	NO	TRAY	
43202-8105	8	8	B	NO	TRAY	
43202-8113	8	8	A	YES	TRAY	
43202-8116	8	6	A	NO	TRAY	
43202-8119	8	4	A	NO	TRAY	
43202-8122	8	2	A	NO	TRAY	
43202-8504	8	8	A	NO	TUBE	
43202-8513	8	8	A	YES	TUBE	

OBS COLORED JACKS EC NO: UCP2008-1189 DRWN:JBELL 2007/11/30 CHKD:LSCHMIDT 2008/02/20 APPR:FSM/TH 2008/03/04	QUALITY SYMBOLS  = 0  = 0.010	GENERAL TOLERANCES (UNLESS SPECIFIED)		DIMENSION STYLE IN/MM		SCALE 4:1	DESIGN UNITS INCH	 THIRD ANGLE PROJECTION		
		4 PLACES ± --- ± ---	3 PLACES ± --- ± .010	2 PLACES ± 0.25 ± .014	1 PLACE ± 0.36 ± ---	ANGULAR ± 1/2°	DRAWN BY JBS	DATE 2000/10/03	TITLE ULTRA LOW PROFILE RIGHT ANGLE MODULAR JACK ASSEMBLY	
		DRAFT WHERE APPLICABLE MUST REMAIN WITHIN DIMENSIONS					APPROVED BY BW	DATE 2000/10/03	MOLEX INCORPORATED	
		SEE CHART					MATERIAL NO.	DOCUMENT NO.	SDA-43202	

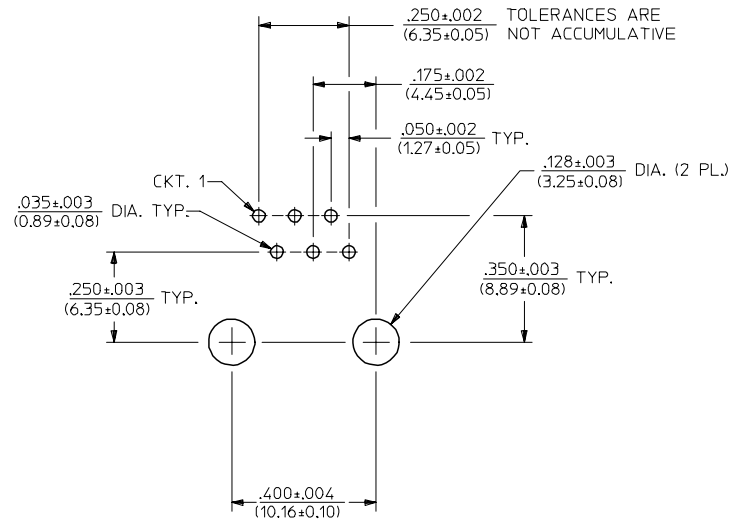

PC BOARD LAYOUT FOR 6 POSITION HOUSING
(6 CIRCUIT FOOT PRINT SHOWN)
(COMPONENT SIDE OF BOARD)

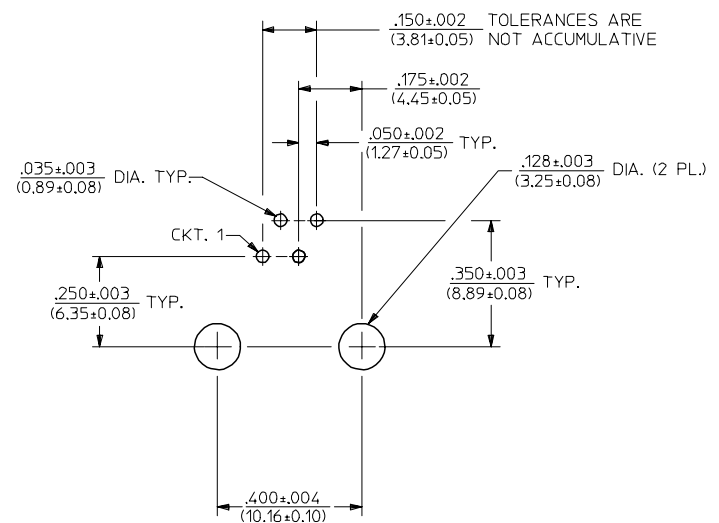

PC BOARD LAYOUT FOR 6 POSITION HOUSING
(4 CIRCUIT FOOT PRINT SHOWN)
(COMPONENT SIDE OF BOARD)

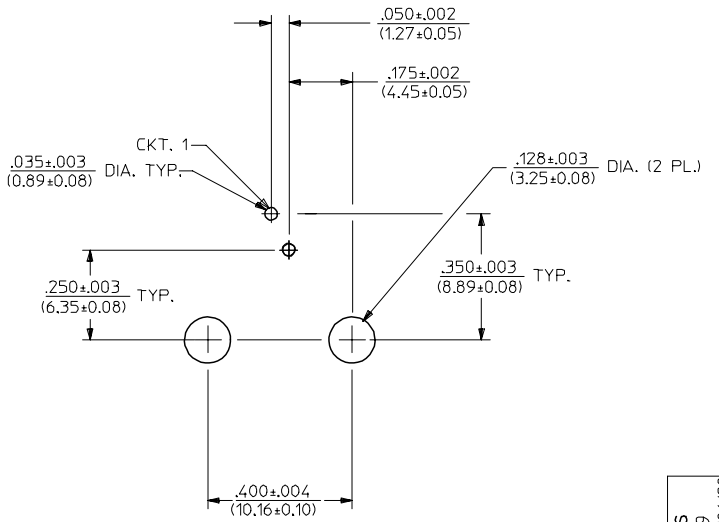

PC BOARD LAYOUT FOR 6 POSITION HOUSING
(2 CIRCUIT FOOT PRINT SHOWN)
(COMPONENT SIDE OF BOARD)

NOTES:
1. RECOMMENDED PCB THICKNESS: .062±.005/(1.57±0.13)

ADD PCB THICKNESS EC NO: UCP2005-2739 DRWN:L.SCHMIDT 2005/06/20 CHKD:ELHAG 2005/06/22 APPR:FSMITH 2005/06/23 REV L2	QUALITY SYMBOLS	GENERAL TOLERANCES (UNLESS SPECIFIED)	SCALE 4:1	DESIGN UNITS INCH	THIRD ANGLE PROJECTION	REVISE ON CAD ONLY	
		mm	INCH	DIMENSION STYLE IN/MM	TITLE		
		4 PLACES ± --- ± ---	± .010	DRAWN BY L.E.LENZ	DATE 1995/03/09	ULTRA LOW PROFILE RIGHT ANGLE MODULAR JACK ASSEMBLY	
		3 PLACES ± --- ± ---	± .014	CHECKED BY JTR	DATE 1995/03/09	MOLEX MOLEX INCORPORATED	
	2 PLACES ± 0.25 ± ---	± .014	APPROVED BY RAS	DATE 1995/03/09	MATERIAL NO. SEE SHT 6	DOCUMENT NO. SDA-43202	
	1 PLACE ± 0.36 ± ---	± ---	DRAFT WHERE APPLICABLE MUST REMAIN WITHIN DIMENSIONS		SHEET NO. 8 OF 9		
		ANGULAR ±1/2°	THIS DRAWING CONTAINS INFORMATION THAT IS PROPRIETARY TO MOLEX INCORPORATED AND SHOULD NOT BE USED WITHOUT WRITTEN PERMISSION				