

UNIT:MM

REVISION INFORMATION			
Rev.	Rev. Date	Modified By	Brief Description
A/0	19-12-06	T1206A	NEW DRAWING

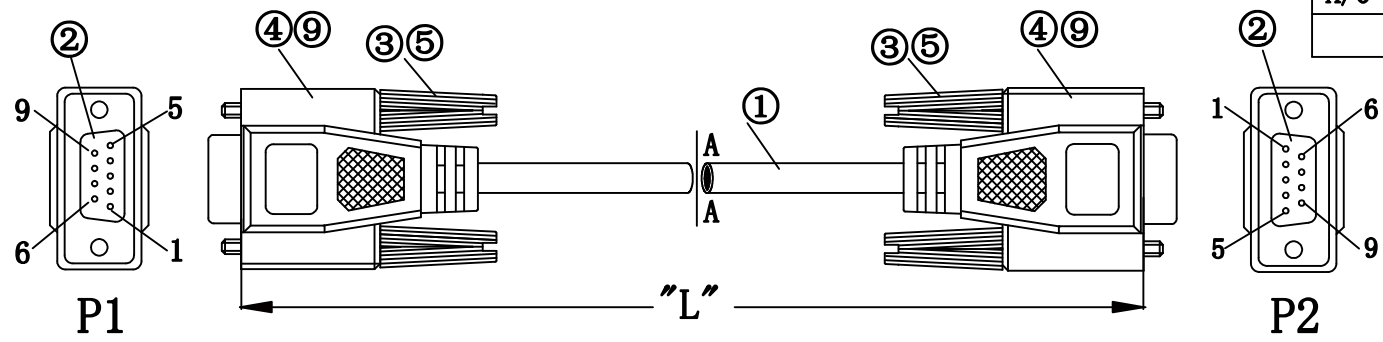

PIN ASSIGNMENT:

P1	COLOR	P2
1	BLACK	1
2	GREY	2
3	YELLOW	3
4	PURPLE	4
5	ORANGE	5
6	RED	6
7	BROWN	7
8	GREEN	8
9	BLUE	9
SHELL	D. W	SHELL

Electrical test:
 1. 100% short, (Open, Short, Miss Wire)
 2. Conduct resistance:2 Ohm(max)
 3. Insulation resistance:5Mohm(min)
 4. Hi-Pot:300V DC/10ms

PART NO	WIRE LENGTH "L"	BUYER COLOR	VENDOR COLOR	CUT LENGTH
710-10026-00500	5000±100	BEIGE	IV-29#	5020-5030MM

CnC Tech, LLC
 Industrial Cable and Connector Technology
 710-10025-00200
 1PC
 RoHS 1821

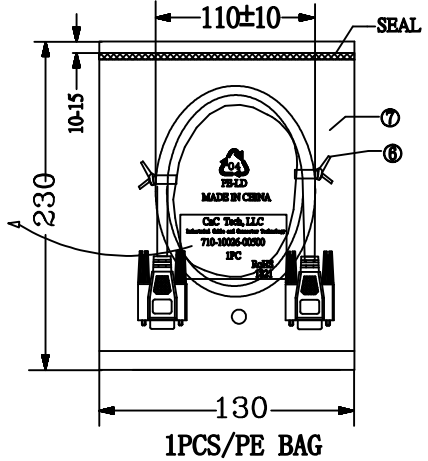

NO.	NAME	QTY	SPECIFICATION
⑨	TUBE	2	HEAT SHRINK TUBE BLACK OD:1.5*L15MM
⑧	PE BAG	1/5	CLEAR SIZE:330X380X0.05mm PRINT BLACK"MADE IN CHINA"+*5PCS"
⑦	PE BAG	1	CLEAR SIZE:210X250X0.05mm PRINT BLACK"MADE IN CHINA"+1PC"
⑥	TIE	2	WHITE L=120mm
⑤	MOLDED		2002-134/135 (PVC 30P COLOR:IV-29#)
④	MOLDED		2002-133 (PVC 40P COLOR:IV-29#)
③	SCREW	4	THUMB SCREW 4*47MM (4#-40UNC) NICKEL
②	CONN	2	DB 9PIN FEMALE PIN G/F SHELL-NICKEL SOLDER TYPE INSULATION COLOR:BLUE
①	CABLE	1	NOUL 30AWG (7/0.10)*9C+D. W+AL/MY+JACKET COLOR:BEIGE (IV-29#) OD:5.0mm

CnC Tech, LLC
 Industrial Cable and Connector Technology

DRAWN BY:	DATE: 2018/12/06	DESCRIPTION: 9C CABLE DB9P/F+DB9P/F
CHECKED BY:	SHEET 1 of 1	ITEM NO. 710-10026-00500
APPROVED BY:	SCALE 1:1	REV. A/0 UNIT: mm