

2500 – 5000 MHz High Linearity LNA

Device Features

- Operated at 3.3V and 5.0V
- 33.0dBm Output IP3 at 0dBm/tone at 3600MHz
- 18.0dB Gain at 3600MHz
- 18.7dBm P1dB at 3600MHz
- 0.59dB NF at 3600MHz
- Fast shut down to support TDD systems
- Lead-free/Green/RoHS Compliant DFN8 2x2 Package

Product Description

BeRex's BLB04 is a high linearity LNA, based on GaAs E-pHEMT process and packaged in a RoHS-compliant DFN 8L 2x2mm² Surface mount package. It is designed for use where low noise and high linearity are required and features low noise and high OIP3 at Frequency range of 2.5~5.0GHz. It is fast enable switching speed for TDD-5G application. All devices are 100% RF/DC tested and classified as HBM ESD Class 1C.

Applications

- Base station Infrastructure
- Commercial/Industrial/Military wireless system
- TDD or FDD LTE system/5G NR

Applications Circuit

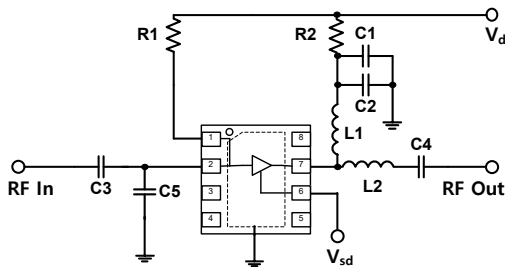

BOM	2.65GHz	3.6GHz	4.55&4.9GHz	Marks
C1	1nF	1nF	1nF	
C2	100pF	100pF	100pF	
C3	5.1pF	2pF	2pF	HQ
C4	5pF	2pF	2pF	
C5	0.75pF	0.3pF	0.3pF	
R1	1.8Kohm	1.8Kohm	1.8Kohm	5V
R2	0ohm	0ohm	0ohm	
L1	2.2nH	1.8nH	2.2nH	
L2	LINE	1nH	LINE	

*3.3V R1 910 ohm

Part Marking (XX:Wafer number)



Electrical Specifications

Device performance _ measured on a BeRex evaluation board at 25°C, V_d=5V, 50 Ω system.

Parameter	Conditions	Min	Typ	Max	Unit
Operational Frequency Range		2500		5000	MHz
Test Frequency			3600		MHz
Gain		16.5	18.0		dB
Input Return Loss			-21.5		dB
Output Return Loss			-15.0		dB
Output IP3	0 dBm / tone , Δf=1 MHz	30.0	33.0		dBm
Output P1dB		17.7	18.7		dBm
Noise Figure			0.59	0.79	dB

* Noise Figure data has input trace loss de-embedded.

Device performance _ measured on a BeRex evaluation board at 25°C, V_d=3.3V, 50 Ω system.

Parameter	Conditions	Min	Typ	Max	Unit
Operational Frequency Range		2500		5000	MHz
Test Frequency			3600		MHz
Gain		16.3	17.8		dB
Input Return Loss			-19.0		dB
Output Return Loss			-17.0		dB
Output IP3	0 dBm / tone , Δf=1 MHz	31.5	34.5		dBm
Output P1dB		14.5	15.5		dBm
Noise Figure			0.58	0.78	dB

* Noise Figure data has input trace loss de-embedded.

Recommended Operating Conditions¹

Parameter	Min	Typ	Max	Unit
Bandwidth	2500		5000	MHz
I _d @ (V _d = 5.0V)	39	49	59	mA
I _d @ (V _d = 3.3V)	36	44	52	mA
V _d	3.3	5.0	5.25	V
dG/dT		-0.005		dB/°C
R _{TH}		53		°C/W
Operating Case Temperature	-40		+125	°C

Electrical specifications are measured at specified test conditions.

Specifications are not guaranteed over all recommended operating conditions.

2500 – 5000 MHz High Linearity LNA

Recommended Operating Conditions²

Parameter	Condition	Min.	Typical	Max.	Unit
Shutdown Control	On state	0		0.9	V
	Off state(shutdown)	1.17		V _d	V
Current, I _d	On state 5V	39	49	59	mA
	On state 3.3V	36	44	52	mA
	Off state(shutdown)	5	7	9	mA
Shutdown pin current, I _{sd}	1.17V ≤ V _{sd} < V _D		200		uA
Switching Time	Rise time(10% to 90%)		150		ns
	Fall time(90% to 10%)		50		ns

Absolute Maximum Ratings

Parameter	Rating	Unit
Storage Temperature	-55 to +155	°C
Junction Temperature	+150	°C
Supply Voltage	+7.0	V
Supply Current	130	mA
Input RF Power	30	dBm

Operation of this device above any of these parameters may result in permanent damage.

Typical Performance (V_d=5.0V, I_d=49mA, T=25°C)

Parameter	Frequency				Unit
V _d = 5V	2650	3600	4550	4900	MHz
Gain	19.2	18.0	16.0	15.2	dB
S11	-10.5	-21.5	-13.4	-11.0	dB
S22	-8.0	-15.0	-11.2	-10.0	dB
OIP3	34.0	33.0	36.5	36.5	dBm
P1dB	21.0	18.7	18.0	17.5	dBm
5G NR ACLR*	10.0	7.6	8.0	7.0	dBm
Noise Figure	0.52	0.59	0.74	0.78	dB

Typical Performance (V_d=3.3V, I_d=44mA, T=25°C)

Parameter	Frequency				Unit
V _d = 5V	2650	3600	4550	4900	MHz
Gain	19.0	17.8	15.8	15.0	dB
S11	-10.5	-19.0	-13.5	-11.0	dB
S22	-9.0	-17.0	-11.8	-10.0	dB
OIP3	34.0	34.5	35.0	35.0	dBm
P1dB	18.0	15.5	15.0	14.8	dBm
5G NR ACLR*	6.4	4.4	4.3	3.7	dBm
Noise Figure	0.47	0.58	0.73	0.77	dB

*ACLR Channel Power measured at -50dBc.

- 5G NR Downlink FR1 : SCS 30KHz, CBW 100MHz, 256QAM, PAR 9.66 at 0.01% Prob.

* Noise Figure data has input trace loss de-embedded.

2500 – 5000 MHz High Linearity LNA

V-I Characteristics

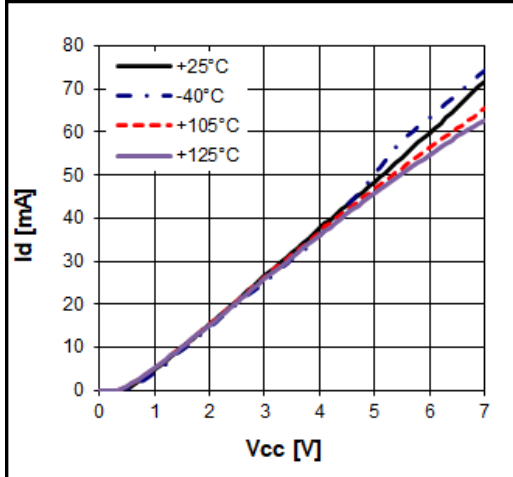

Evaluation Board

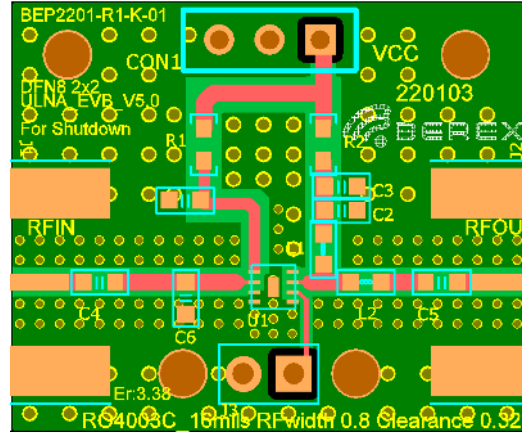

*Dielectric constant _ 4.2 *RF pattern width 24mil *16mil thick RO4003 PCB

Pin Configuration and Description

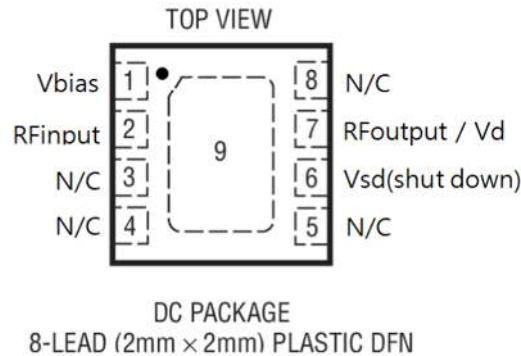

Pin No.	Name	Description
1	Vbias	Vbias sets Idq through external resistor for V _d =5V or V _d =3.3V.
2	RFinut	RFinut pin. A DC Block with High Q performance is required.
6	Vsd(shut down)	Power on/off control pin. 1.17V ≤ V _{sd} disables device. If function is not desired, may be connected to ground.
7	RFoutput / Vd	RFoutput / V _d pin. Supply V _d through choke/Inductor for the device.
3,4,5,8	NC	No internal connection to die. May be connected to ground.
9	Backside Paddle	Exposed Pad is RF/DC ground, must be soldered to PCB.

2500 – 5000 MHz High Linearity LNA

Typical Device Data

S-parameters ($V_d=5.0V$, $I_d=49mA$, $T=25^\circ C$)

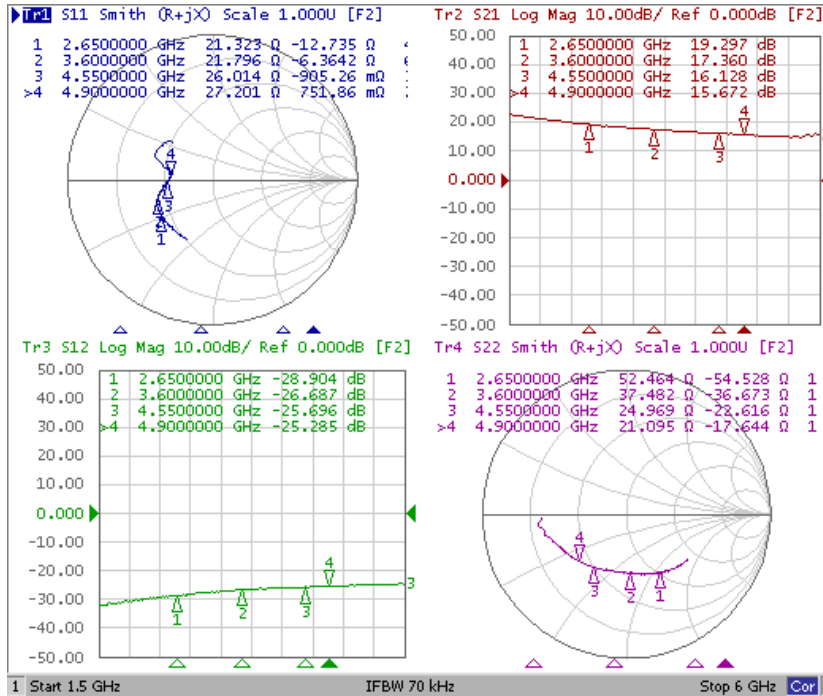

S-Parameter

($V_d=5.0V$, $I_d=49mA$, $T=25^\circ C$, calibrated to device leads)

Freq [MHz]	S11 Mag	S11 Ang	S21 Mag	S21 Ang	S12 Mag	S12 Ang	S22 Mag	S22 Ang
2500	0.44	-143.54	9.70	52.99	0.04	30.01	0.48	-56.11
2600	0.44	-145.97	9.32	49.22	0.04	27.62	0.47	-58.80
2800	0.44	-150.75	9.04	42.55	0.04	24.59	0.45	-64.33
3000	0.43	-154.00	8.44	36.32	0.04	19.84	0.43	-68.68
3200	0.41	-157.36	8.12	29.99	0.04	16.01	0.41	-73.81
3400	0.41	-160.33	7.76	24.41	0.04	13.60	0.40	-79.24
3600	0.40	-163.16	7.43	18.50	0.05	11.13	0.39	-85.42
3800	0.38	-166.53	7.25	12.41	0.05	8.57	0.39	-92.20
4000	0.36	-169.17	6.99	5.46	0.05	6.38	0.39	-100.11
4200	0.34	-172.18	6.75	-0.83	0.05	3.20	0.39	-107.57
4400	0.32	-174.84	6.50	-7.74	0.05	-0.51	0.40	-114.68
4600	0.30	-178.87	6.29	-13.78	0.05	-4.55	0.42	-121.92
4800	0.28	177.63	6.10	-20.27	0.05	-7.69	0.44	-129.77
5000	0.27	174.99	5.90	-26.49	0.05	-10.13	0.46	-136.93

2500 – 5000 MHz High Linearity LNA

Application Circuit: 2650 MHz

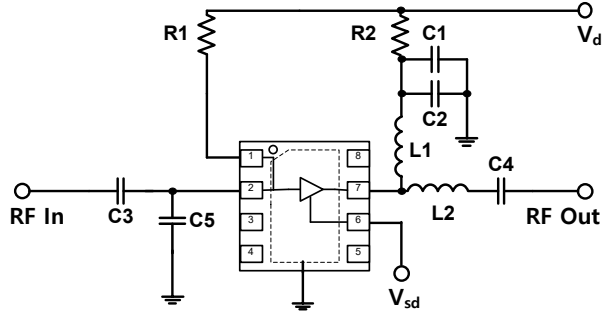
Schematic Diagram	BOM	size	Marks	
	C1	1nF	1608	
	C2	100pF	1608	
	C3	5.1pF	1608	Johanson Technology 251R14S5R1BV4(HighQ)
	C4	5pF	1608	Distance to pin7 : 6.5mm
	C5	0.75pF	1608	Distance to pin2 : 5.0mm
	L1	2.2nH	1608	
	L2	Line	1608	Characteristics change when it is 0ohm.
	R1	1.8Kohm	1608	
	R2	0ohm	1608	

Typical Performance

$V_d = 5V, I_d = 49mA$

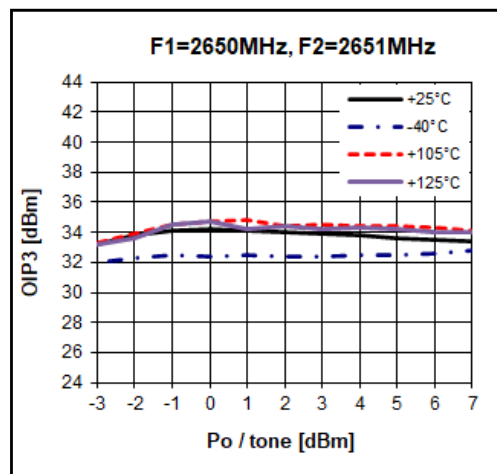
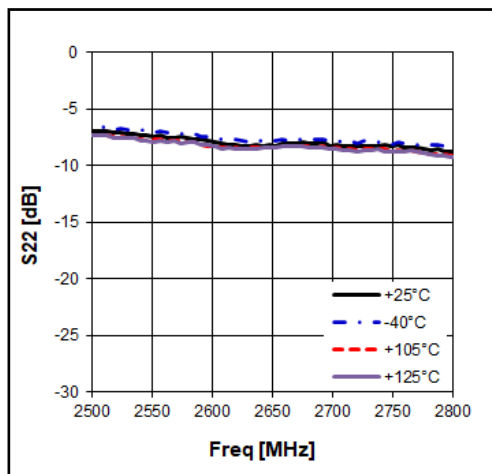
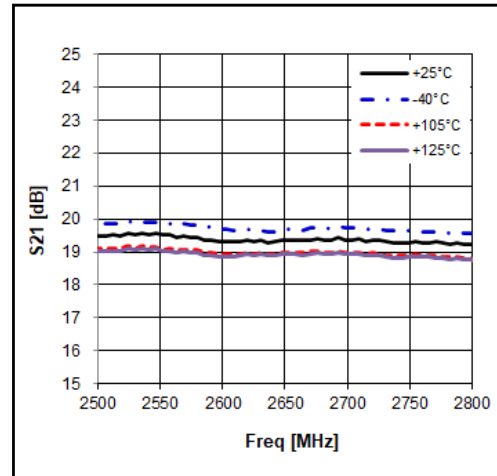
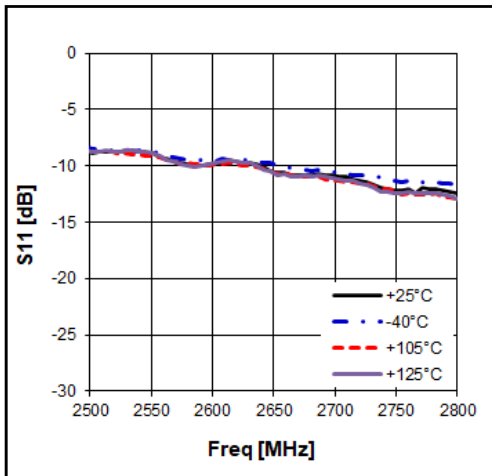

2500 – 5000 MHz High Linearity LNA

$V_d = 5V, I_d = 49mA$

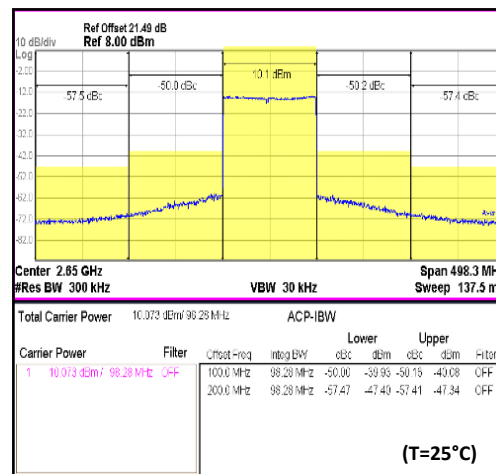
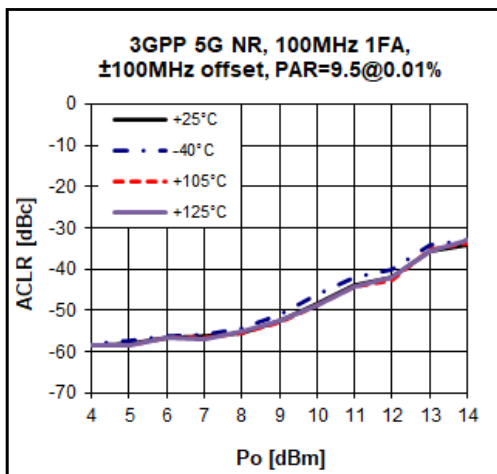
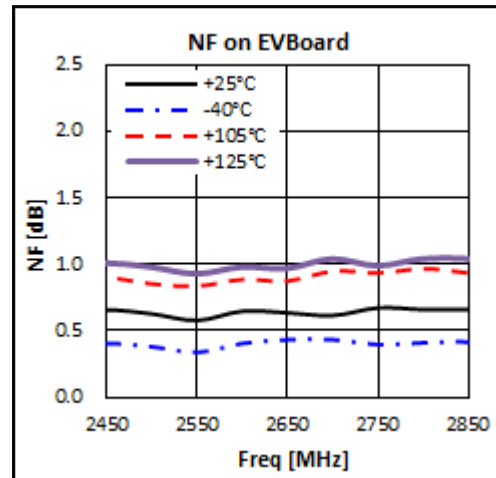
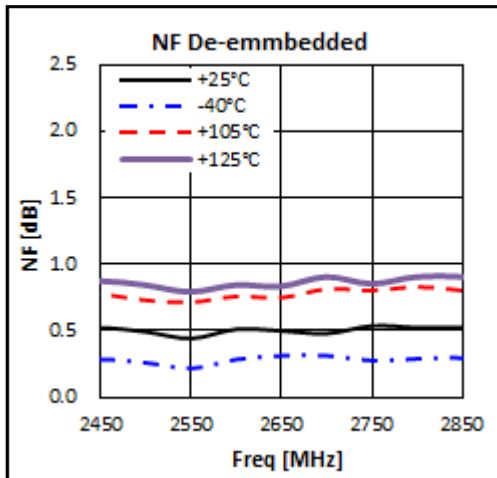
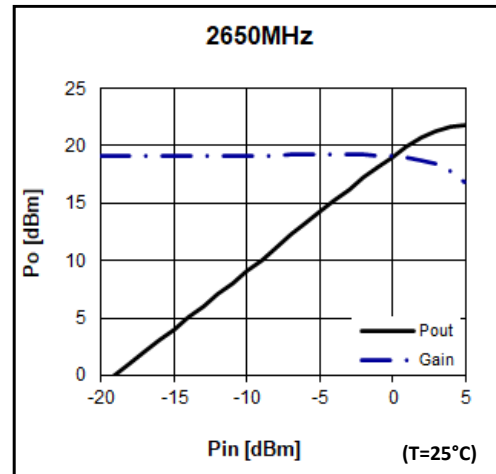
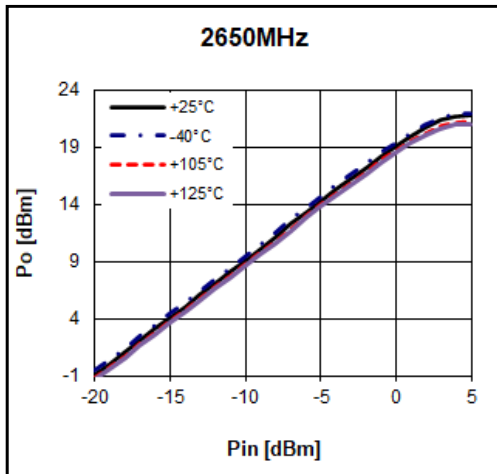

2500 – 5000 MHz High Linearity LNA

Application Circuit: 3600 MHz

Schematic Diagram	BOM	size	Marks	
	C1	1nF	1608	
	C2	100pF	1608	
	C3	2pF	1608	Johanson Technology 251R14S2R0BV4(HighQ)
	C4	2pF	1608	Distance to pin7 : 6.5mm
	C5	0.3pF	1608	Distance to pin2 : 2.9mm
	L1	1.8nH	1608	
	L2	1nH	1608	
	R1	1.8Kohm	1608	
R2	0ohm	1608		

Typical Performance

$V_d = 5V, I_d = 49mA$

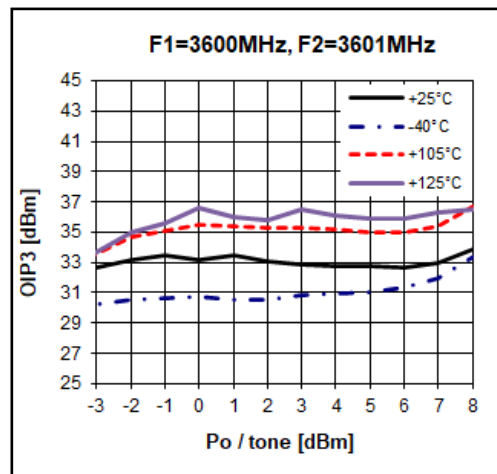
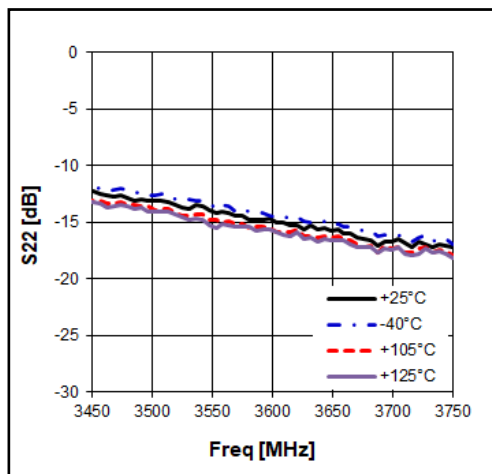
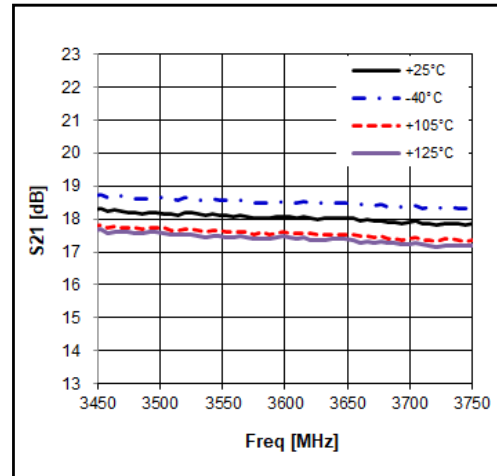
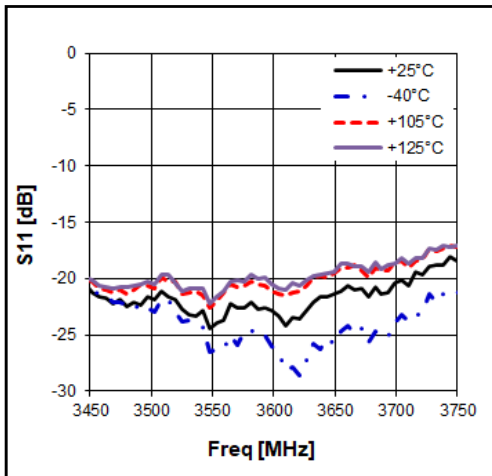

2500 – 5000 MHz High Linearity LNA

$V_d = 5V, I_d = 49mA$

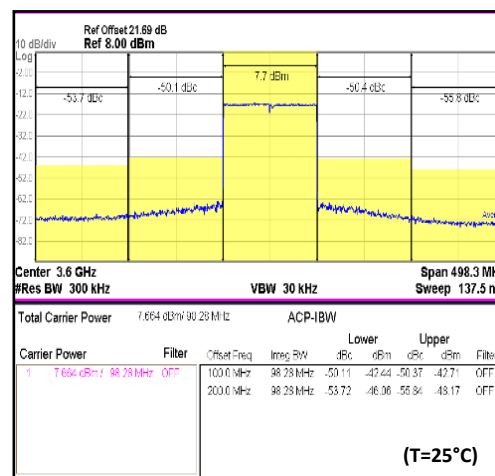
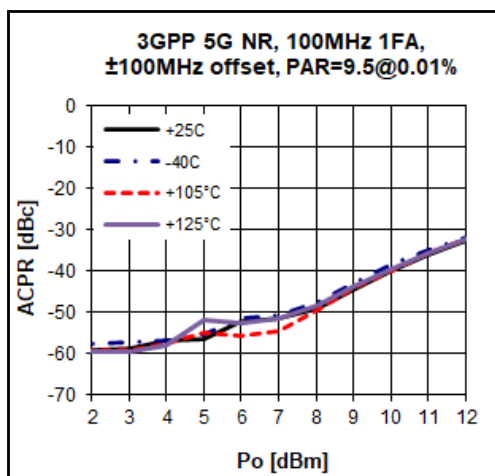
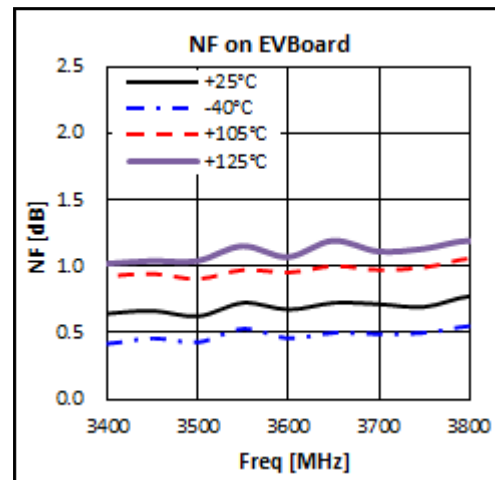
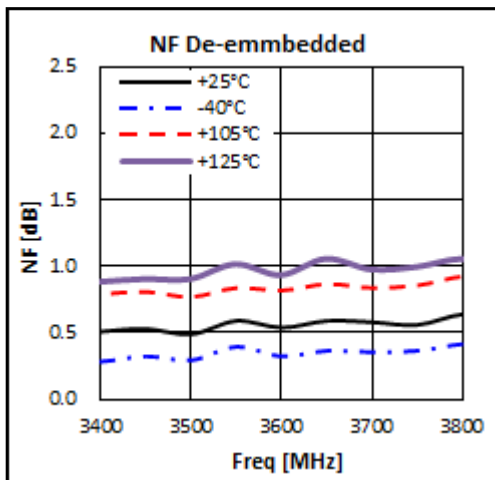
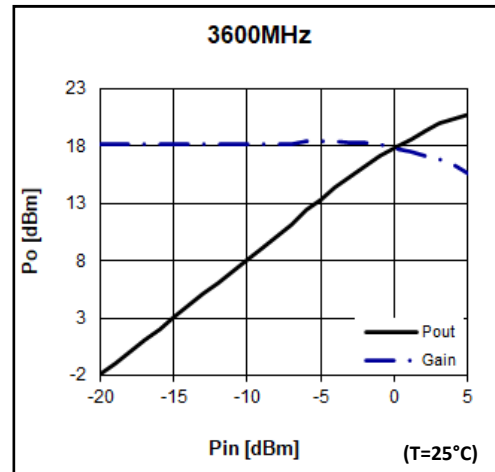
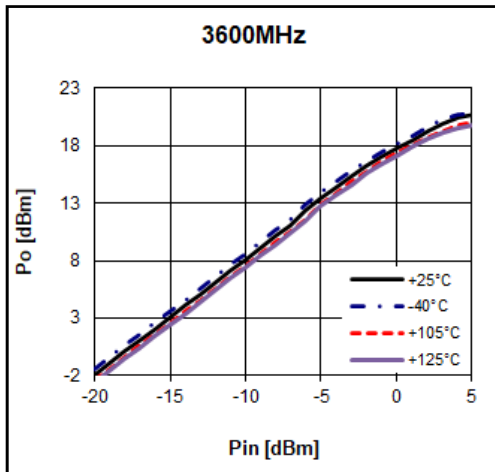

2500 – 5000 MHz High Linearity LNA

Application Circuit: 4550 MHz

Schematic Diagram	BOM	size	Marks	
	C1	1nF	1608	
	C2	100pF	1608	
	C3	2pF	1608	Johanson Technology 251R14S2R0BV4(HighQ)
	C4	2pF	1608	Distance to pin7 : 6.5mm
	C5	0.3pF	1608	Distance to pin2 : 2.1mm
	L1	2.2nH	1608	
	L2	Line	1608	Characteristics change when it is 0ohm.
	R1	1.8Kohm	1608	
	R2	0ohm	1608	

Typical Performance

$V_d = 5V, I_d = 49mA$

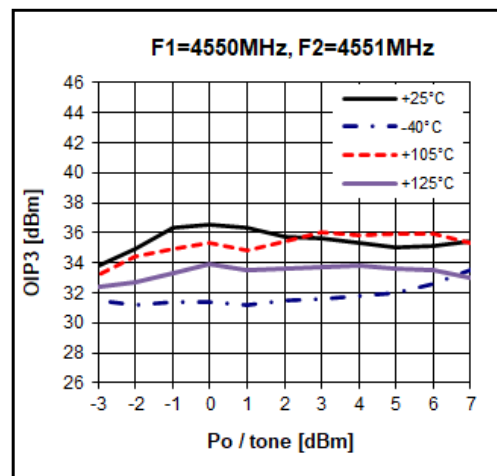
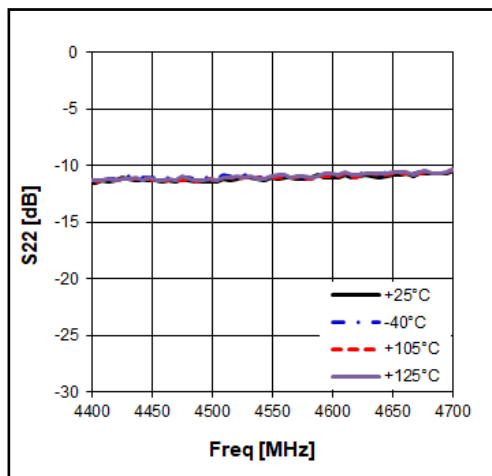
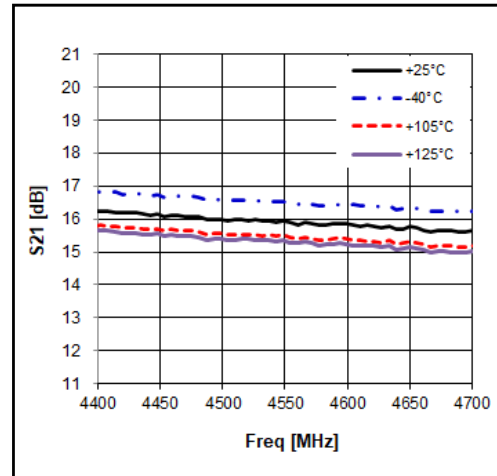
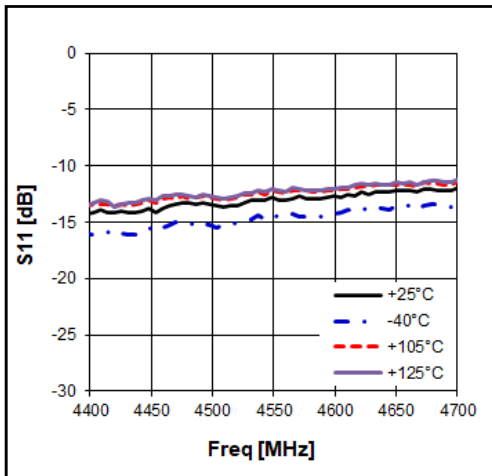

2500 – 5000 MHz High Linearity LNA

$V_d = 5V, I_d = 49mA$

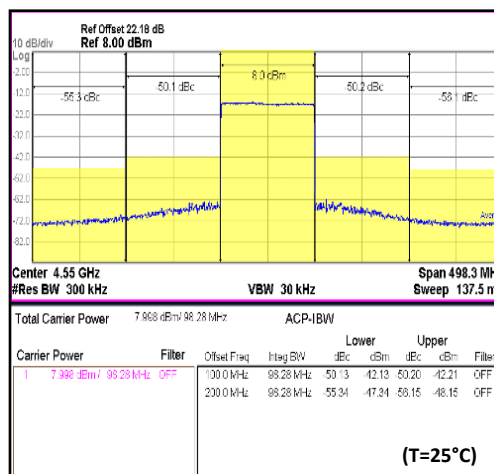
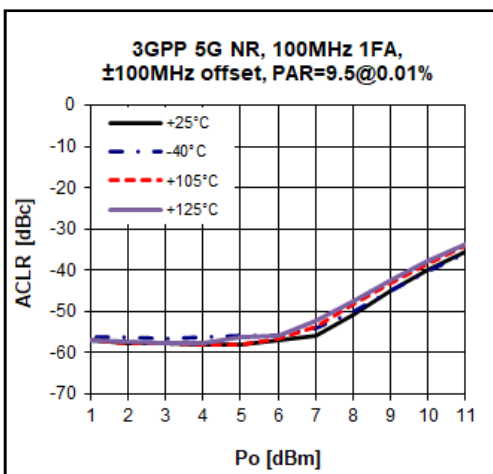
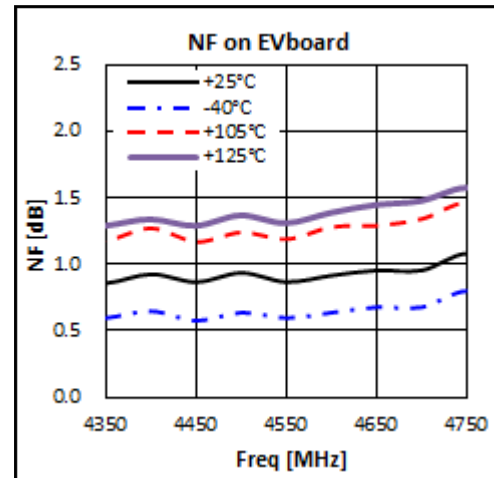
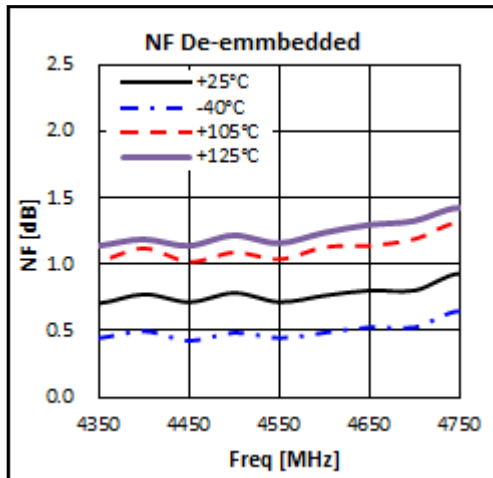
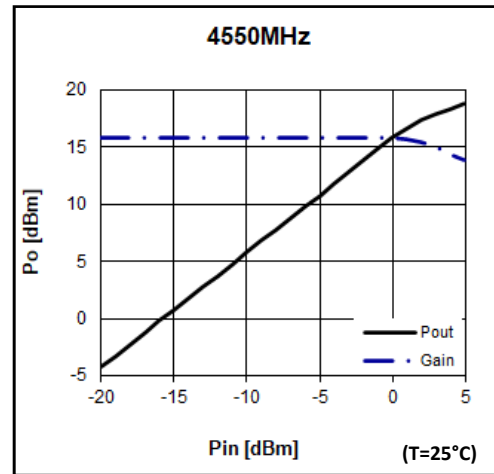
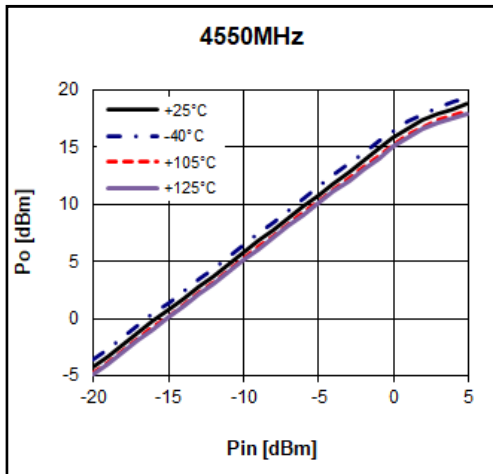

2500 – 5000 MHz High Linearity LNA

Application Circuit: 4900 MHz

Schematic Diagram	BOM	size	Marks	
	C1	1nF	1608	
	C2	100pF	1608	
	C3	2pF	1608	Johanson Technology 251R14S2R0BV4(HighQ)
	C4	2pF	1608	Distance to pin7 : 6.5mm
	C5	0.3pF	1608	Distance to pin2 : 2.1mm
	L1	2.2nH	1608	
	L2	Line	1608	Characteristics change when it is 0ohm.
	R1	1.8Kohm	1608	
	R2	0ohm	1608	

Typical Performance

$V_d = 5V, I_d = 49mA$

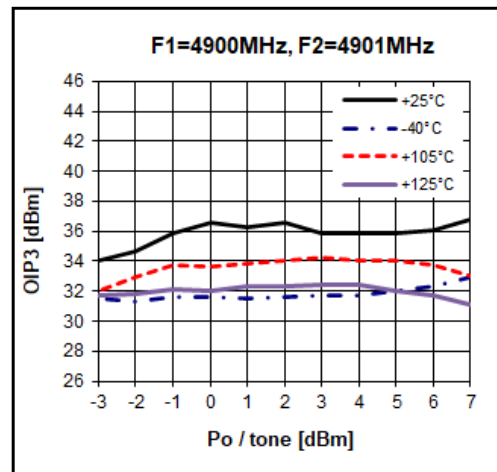
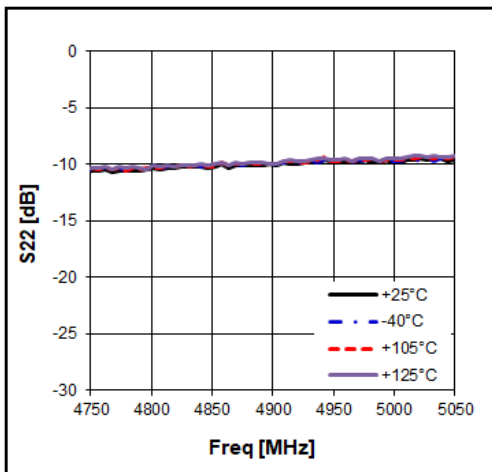
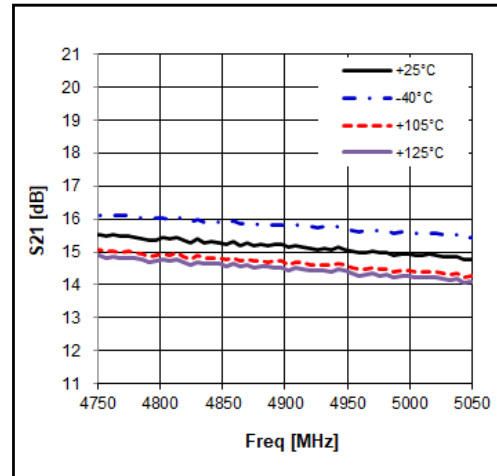
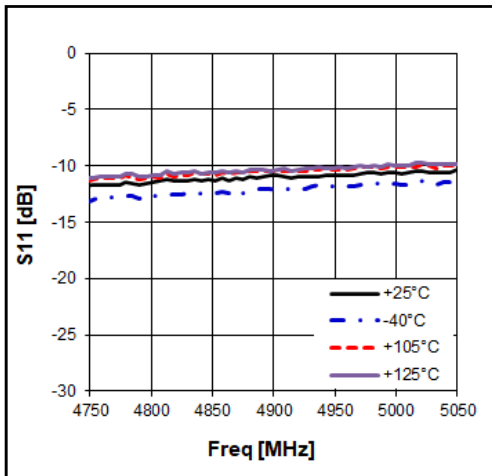

2500 – 5000 MHz High Linearity LNA

$V_d = 5V, I_d = 49mA$

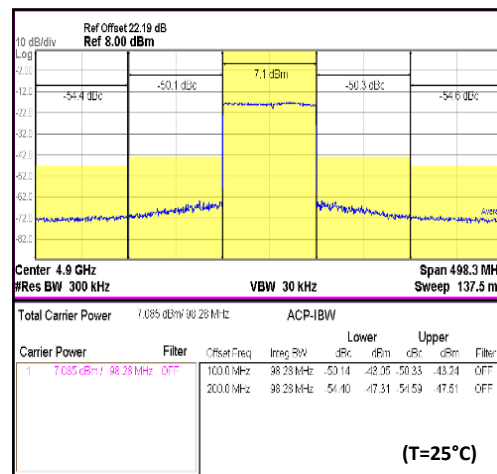
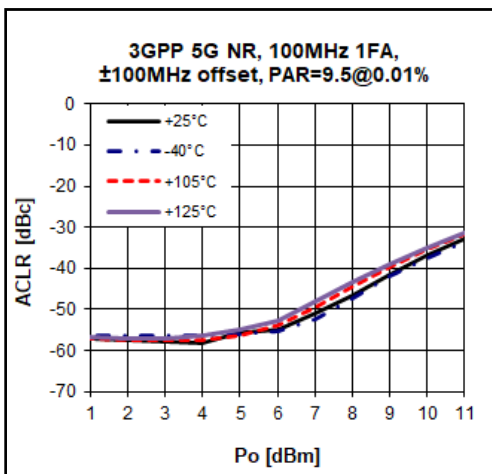
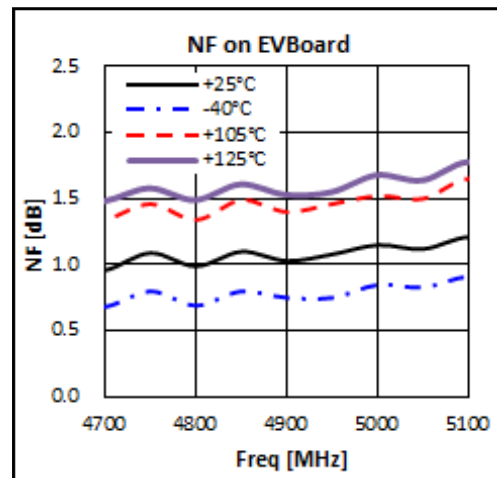
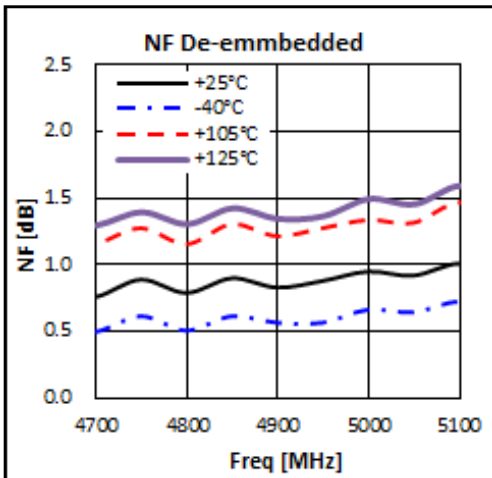
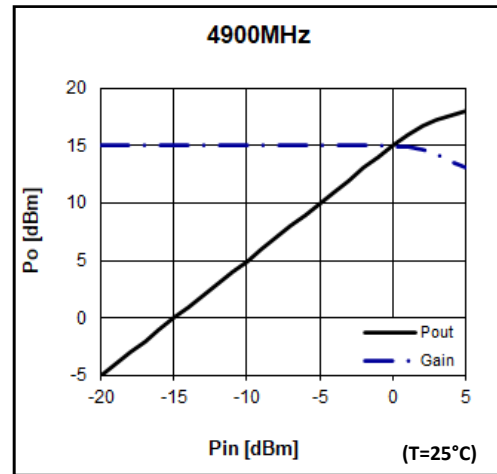
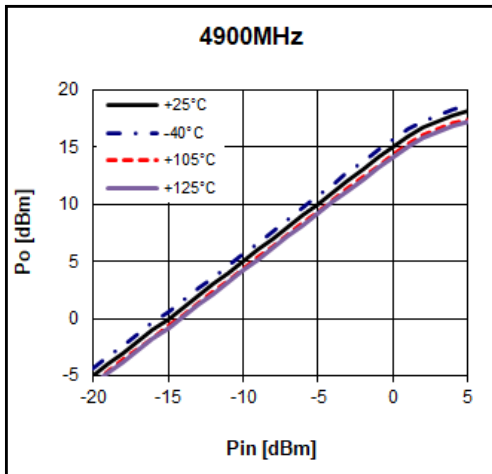

2500 – 5000 MHz High Linearity LNA

Typical Device Data

S-parameters ($V_d=3.3V$, $I_d=44mA$, $T=25^\circ C$)

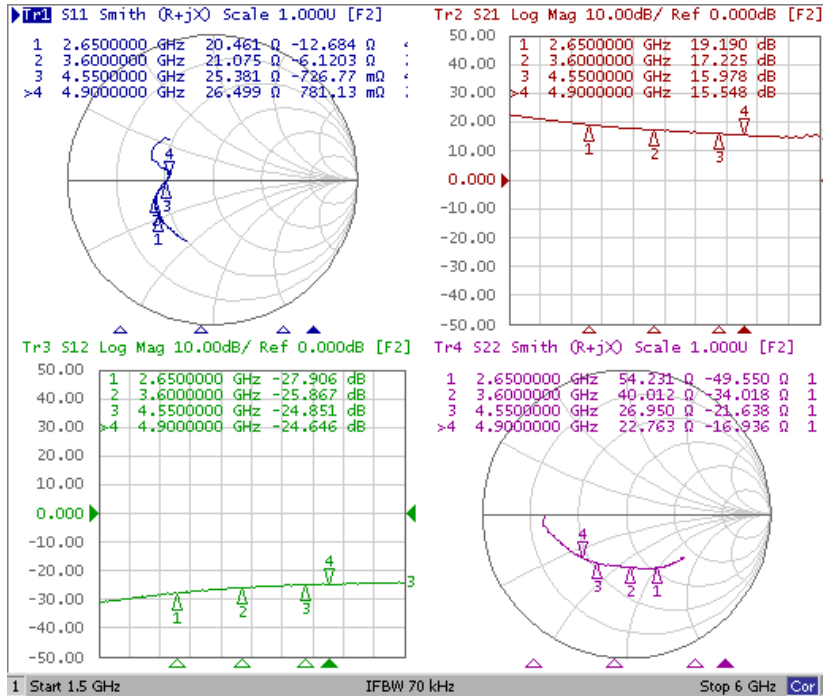

S-Parameter

($V_d=3.3V, I_d = 44mA, T = 25^\circ C$, calibrated to device leads)

Freq [MHz]	S11 Mag	S11 Ang	S21 Mag	S21 Ang	S12 Mag	S12 Ang	S22 Mag	S22 Ang
2500	0.45	-143.44	9.51	50.90	0.04	25.76	0.44	-56.64
2600	0.45	-145.41	9.11	47.97	0.04	25.44	0.43	-58.63
2800	0.44	-149.79	8.74	41.61	0.04	22.57	0.42	-63.19
3000	0.44	-152.84	8.19	36.27	0.04	20.11	0.41	-68.28
3200	0.43	-156.64	7.91	29.69	0.05	16.87	0.39	-74.01
3400	0.42	-160.03	7.58	24.21	0.05	13.97	0.38	-79.68
3600	0.41	-162.97	7.26	18.55	0.05	8.76	0.37	-85.57
3800	0.39	-166.59	7.10	12.57	0.05	6.93	0.37	-92.73
4000	0.37	-169.41	6.88	5.68	0.05	3.61	0.37	-99.73
4200	0.35	-172.10	6.70	-0.47	0.05	0.92	0.38	-107.79
4400	0.34	-175.00	6.39	-7.23	0.06	-3.37	0.38	-114.82
4600	0.32	-178.43	6.25	-13.61	0.06	-5.65	0.40	-122.92
4800	0.31	178.42	6.03	-20.12	0.06	-9.58	0.42	-130.96
5000	0.30	175.22	5.87	-26.08	0.06	-13.90	0.44	-138.67

2500 – 5000 MHz High Linearity LNA

Application Circuit: 2650 MHz

Schematic Diagram	BOM	size	Marks	
	C1	1nF	1608	
	C2	100pF	1608	
	C3	5.1pF	1608	Johanson Technology 251R14S5R1BV4(HighQ)
	C4	5pF	1608	Distance to pin7 : 6.5mm
	C5	0.75pF	1608	Distance to pin2 : 5.0mm
	L1	2.2nH	1608	
	L2	Line	1608	Characteristics change when it is 0ohm.
	R1	910ohm	1608	
	R2	0ohm	1608	

Typical Performance

$V_d = 3.3V, I_d = 44mA$

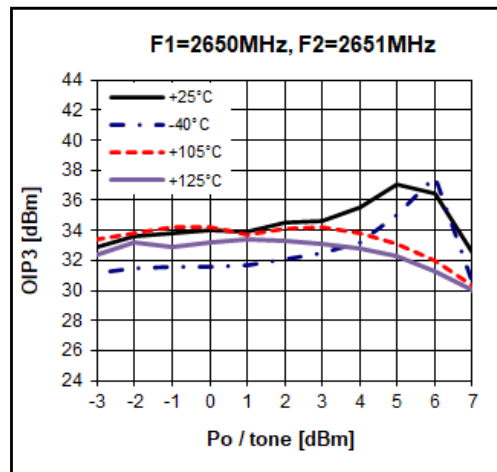
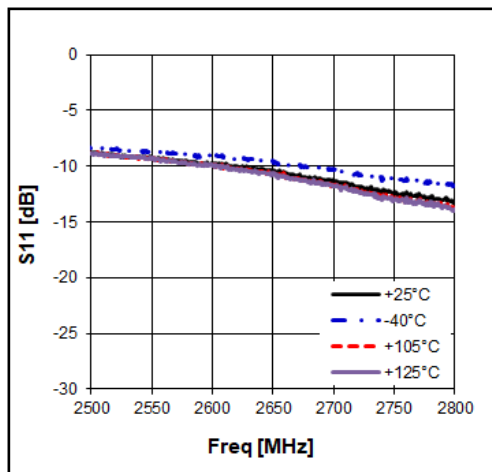
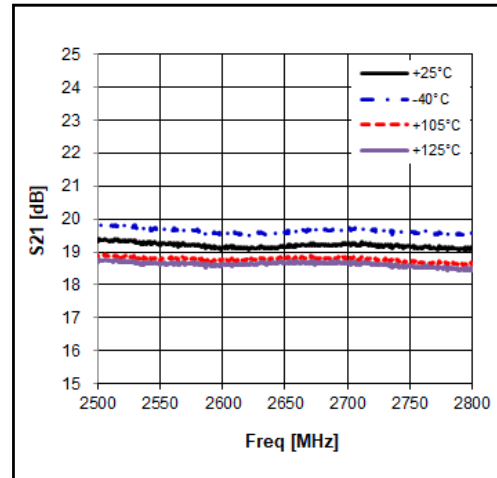
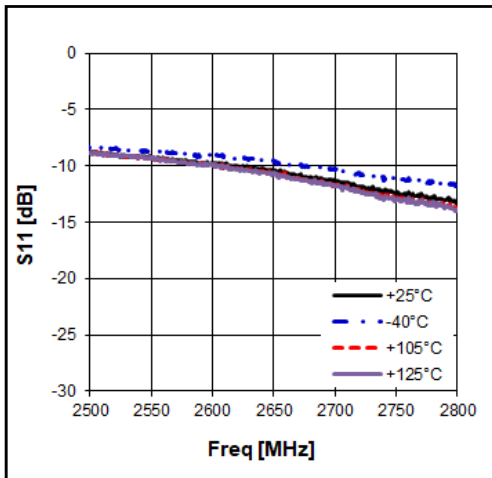

2500 – 5000 MHz High Linearity LNA

$V_d = 3.3V, I_d = 44mA$

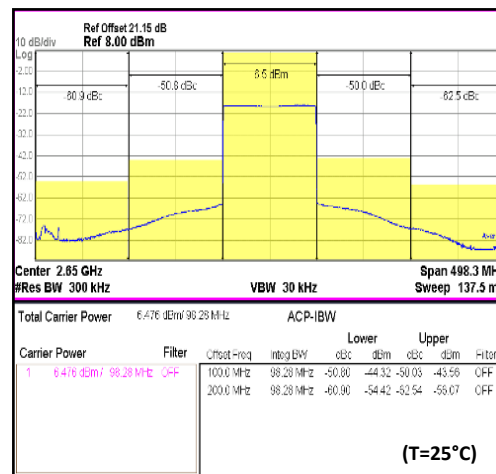
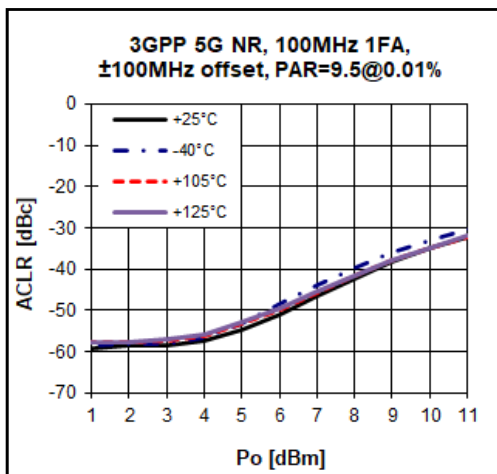
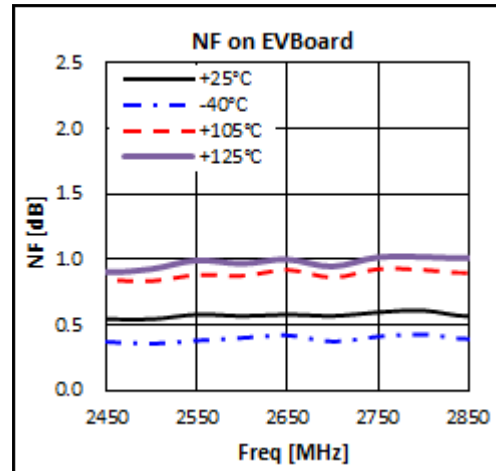
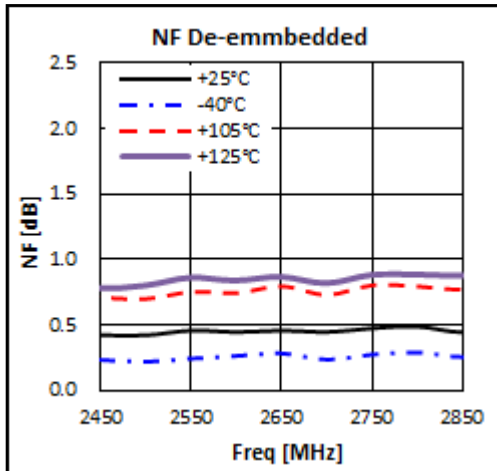
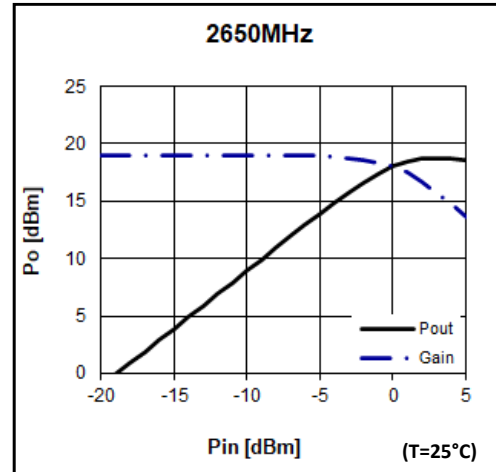
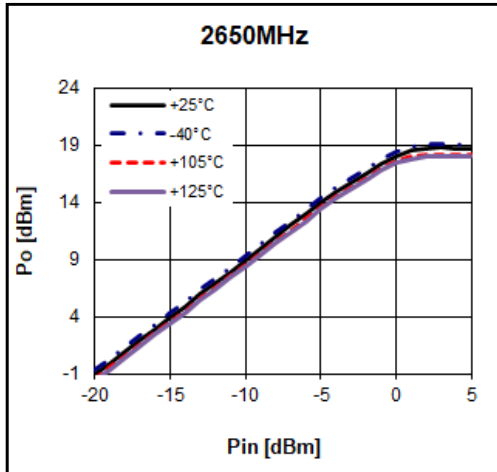

2500 – 5000 MHz High Linearity LNA

Application Circuit: 3600 MHz

Schematic Diagram	BOM	size	Marks	
	C1	1nF	1608	
	C2	100pF	1608	
	C3	2pF	1608	Johanson Technology 251R14S2R0BV4(HighQ)
	C4	2pF	1608	Distance to pin7 : 6.5mm
	C5	0.3pF	1608	Distance to pin2 : 2.9mm
	L1	1.8nH	1608	
	L2	1nH	1608	
	R1	910ohm	1608	
	R2	0ohm	1608	

Typical Performance

$V_d = 3.3V, I_d = 44mA$

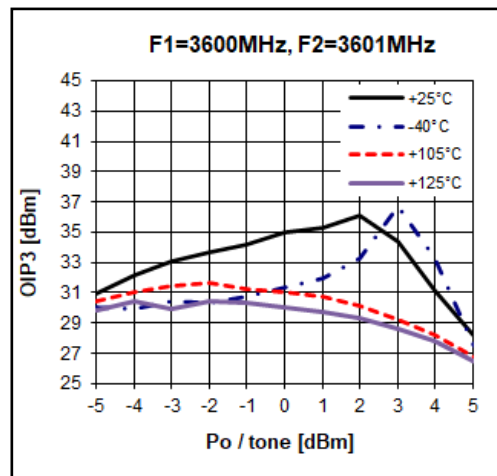
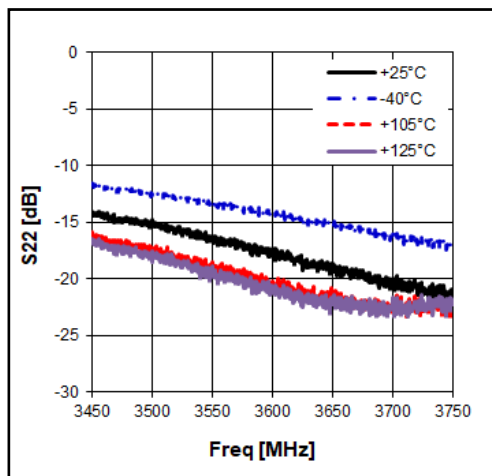
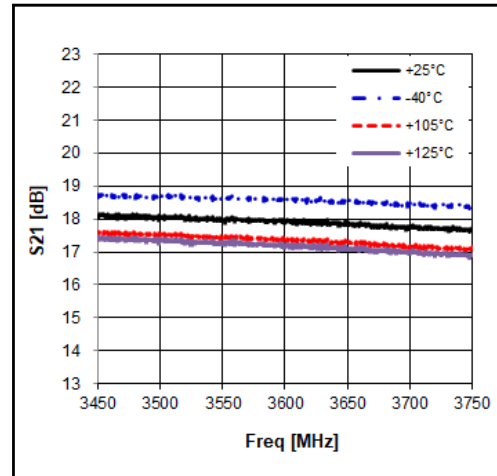
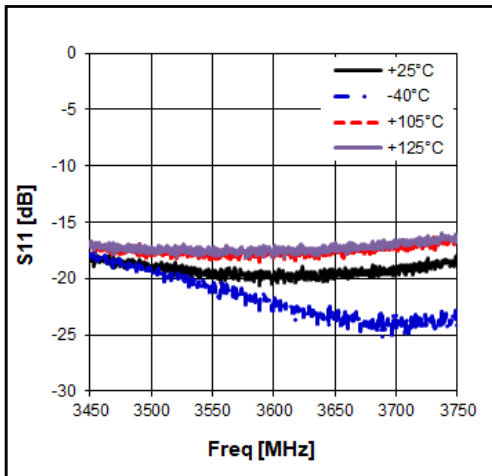

2500 – 5000 MHz High Linearity LNA

$V_d = 3.3V, I_d = 44mA$

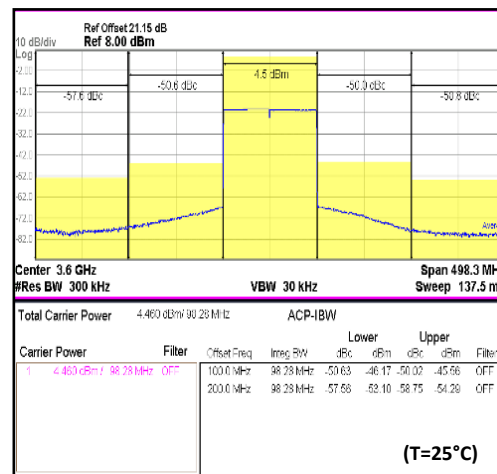
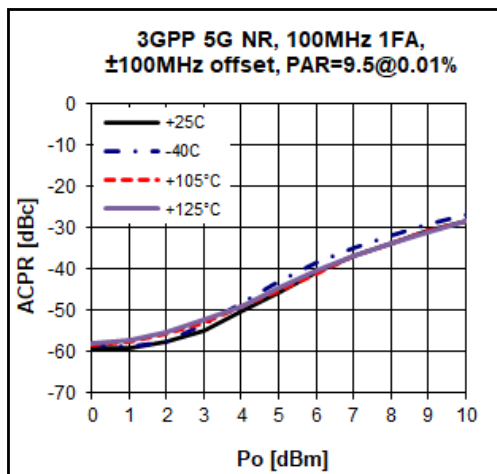
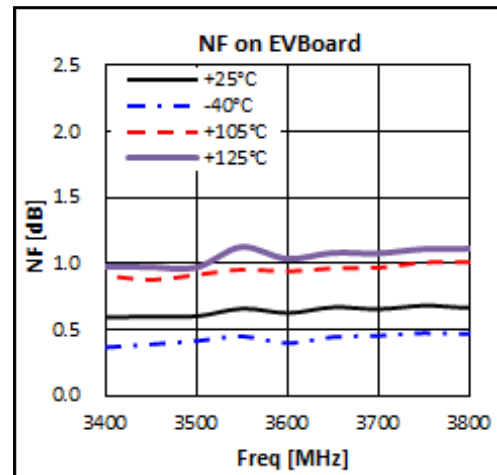
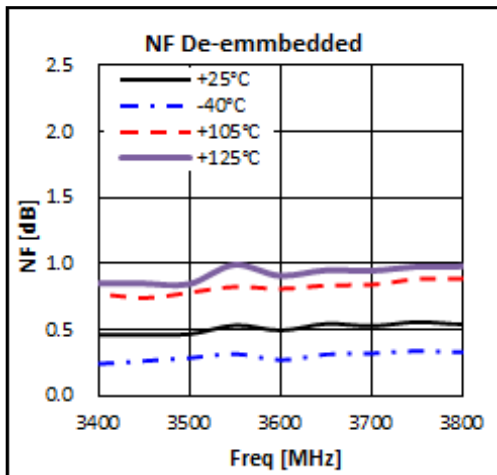
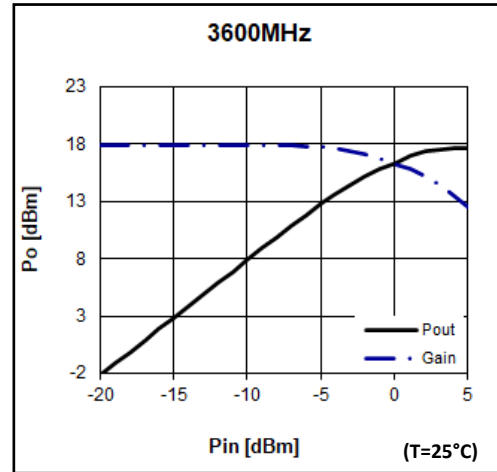
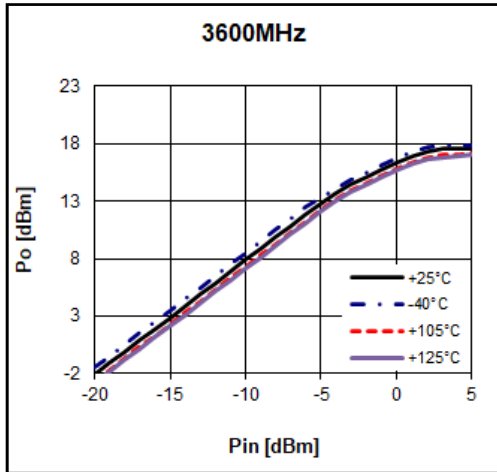

2500 – 5000 MHz High Linearity LNA

Application Circuit: 4550 MHz

Schematic Diagram	BOM	size	Marks	
	C1	1nF	1608	
	C2	100pF	1608	
	C3	2pF	1608	Johanson Technology 251R14S2R0BV4(HighQ)
	C4	2pF	1608	Distance to pin7 : 6.5mm
	C5	0.3pF	1608	Distance to pin2 : 2.1mm
	L1	2.2nH	1608	
	L2	Line	1608	Characteristics change when it is 0ohm.
	R1	1.8Kohm	1608	
	R2	0ohm	1608	

Typical Performance

$V_d = 3.3V, I_d = 44mA$

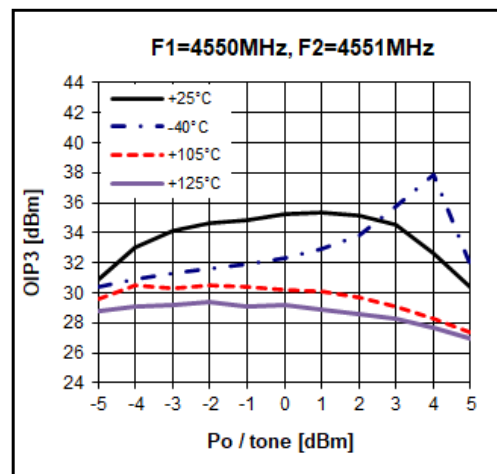
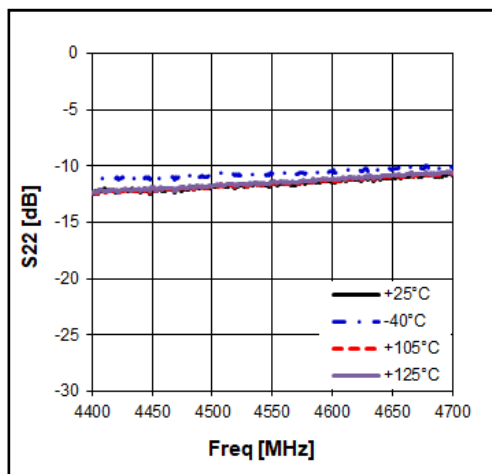
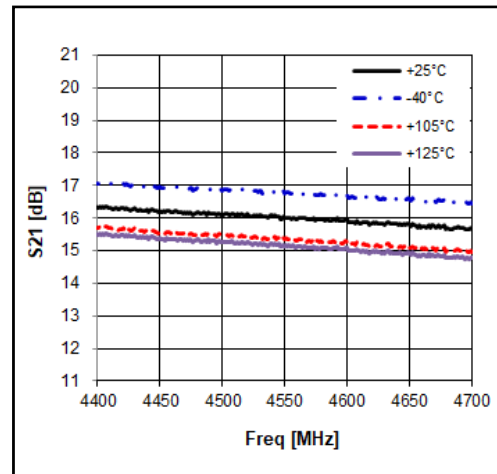
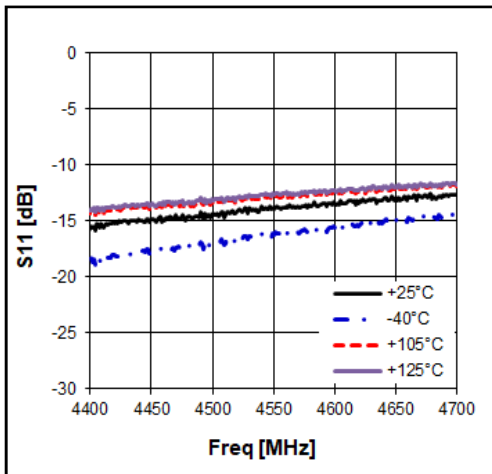

2500 – 5000 MHz High Linearity LNA

$V_d = 3.3V, I_d = 44mA$

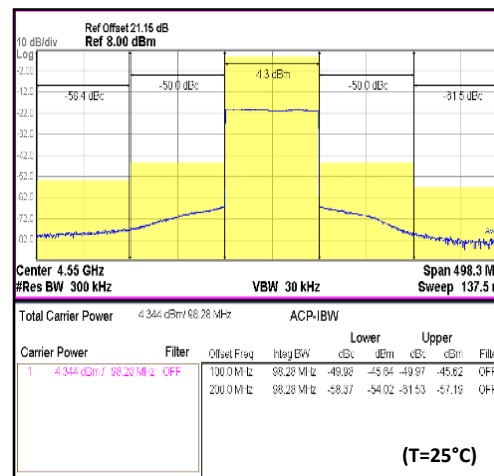
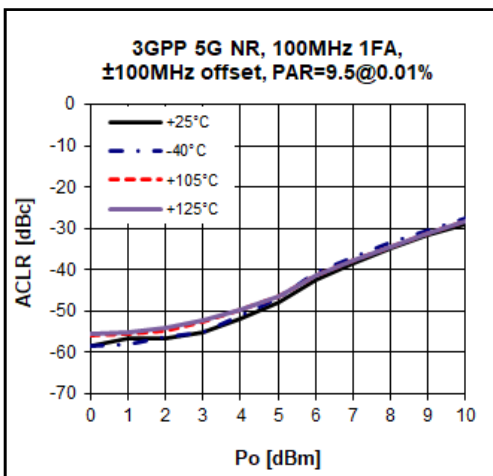
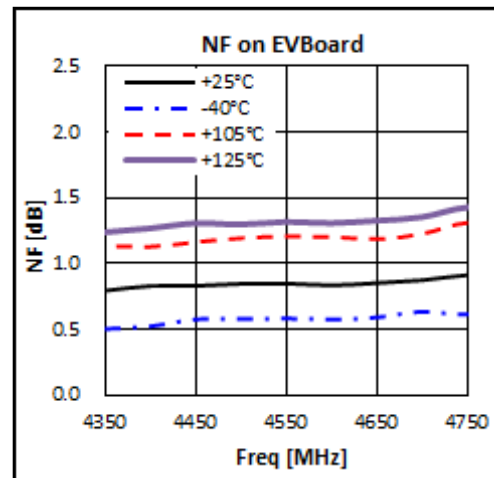
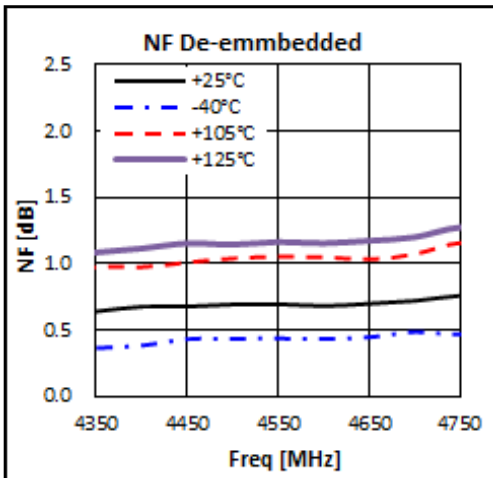
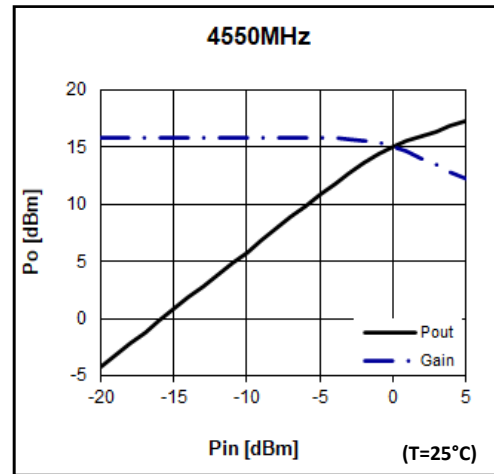
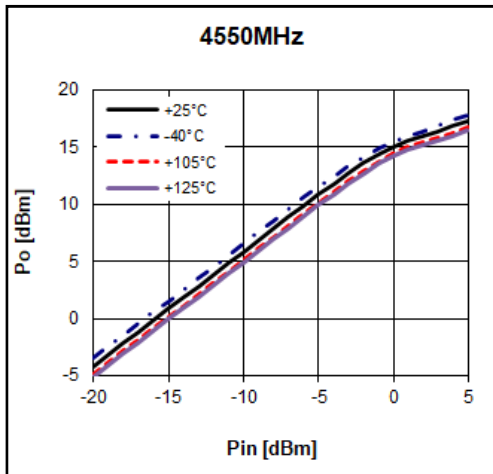

2500 – 5000 MHz High Linearity LNA

Application Circuit: 4900 MHz

Schematic Diagram	BOM	size	Marks	
	C1	1nF	1608	
	C2	100pF	1608	
	C3	2pF	1608	Johanson Technology 251R14S2R0BV4(HighQ)
	C4	2pF	1608	Distance to pin7 : 6.5mm
	C5	0.3pF	1608	Distance to pin2 : 2.1mm
	L1	2.2nH	1608	
	L2	Line	1608	Characteristics change when it is 0ohm.
	R1	1.8Kohm	1608	
	R2	0ohm	1608	

Typical Performance

$V_d = 3.3V, I_d = 44mA$

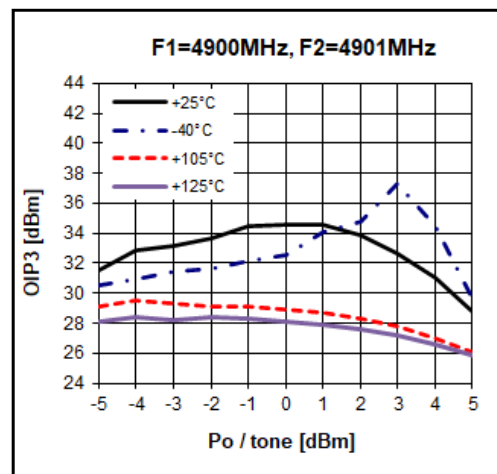
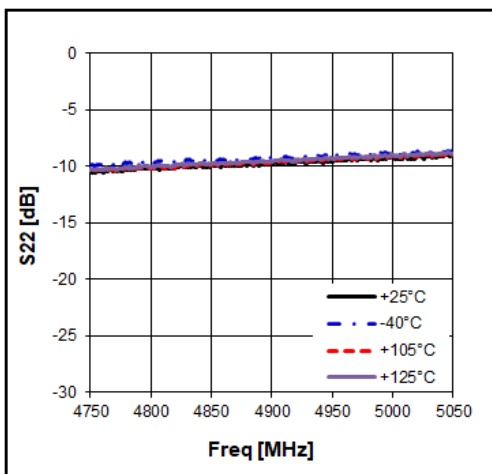
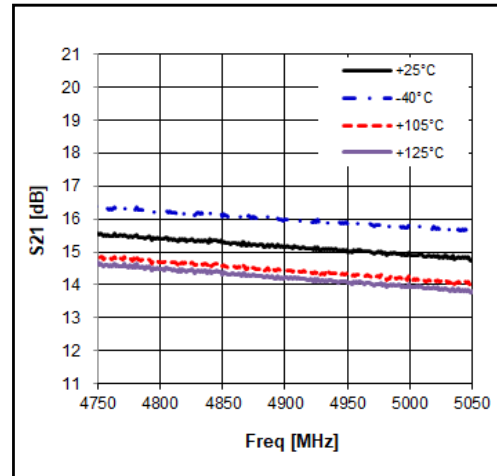
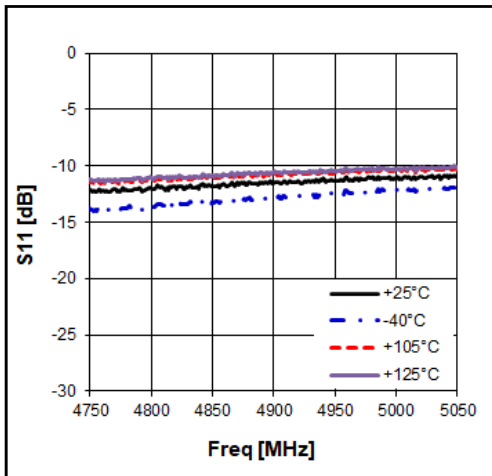

2500 – 5000 MHz High Linearity LNA

$V_d = 3.3V, I_d = 44mA$

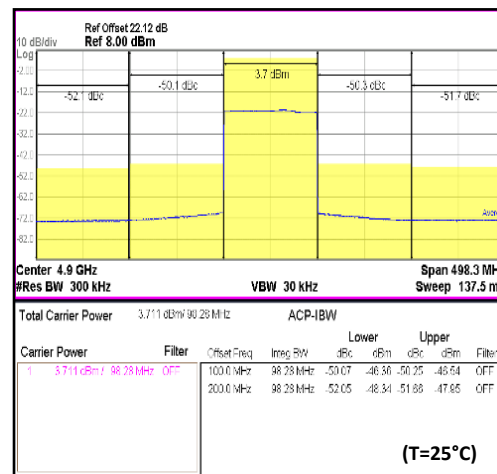
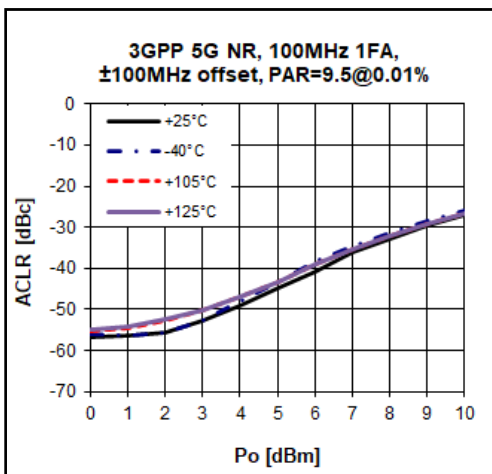
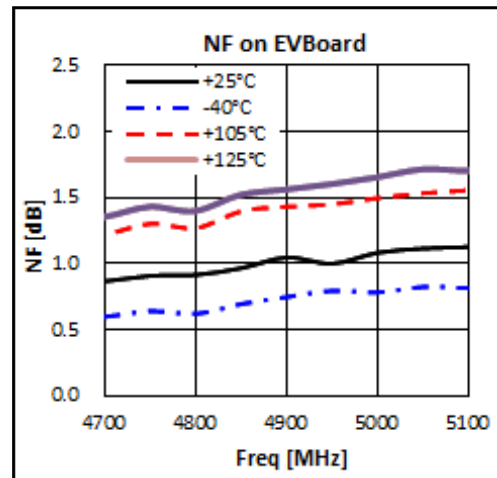
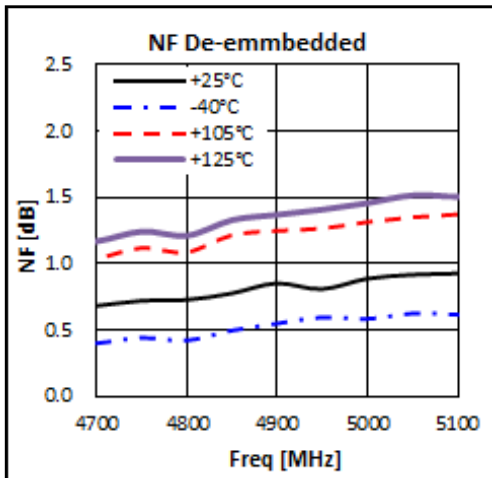
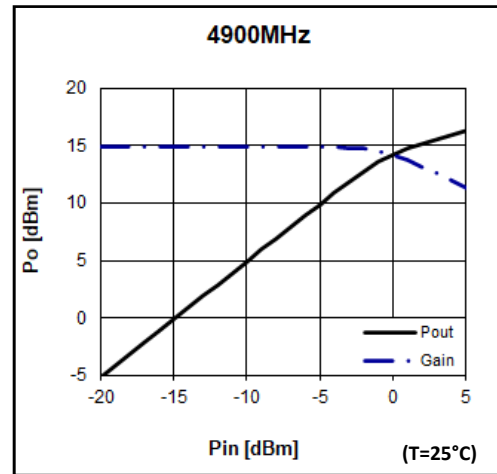
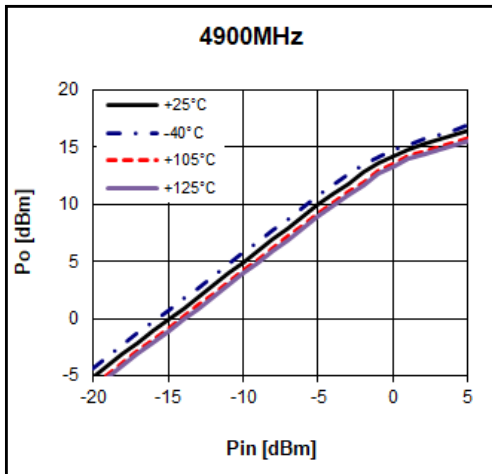

Package Outline Dimension

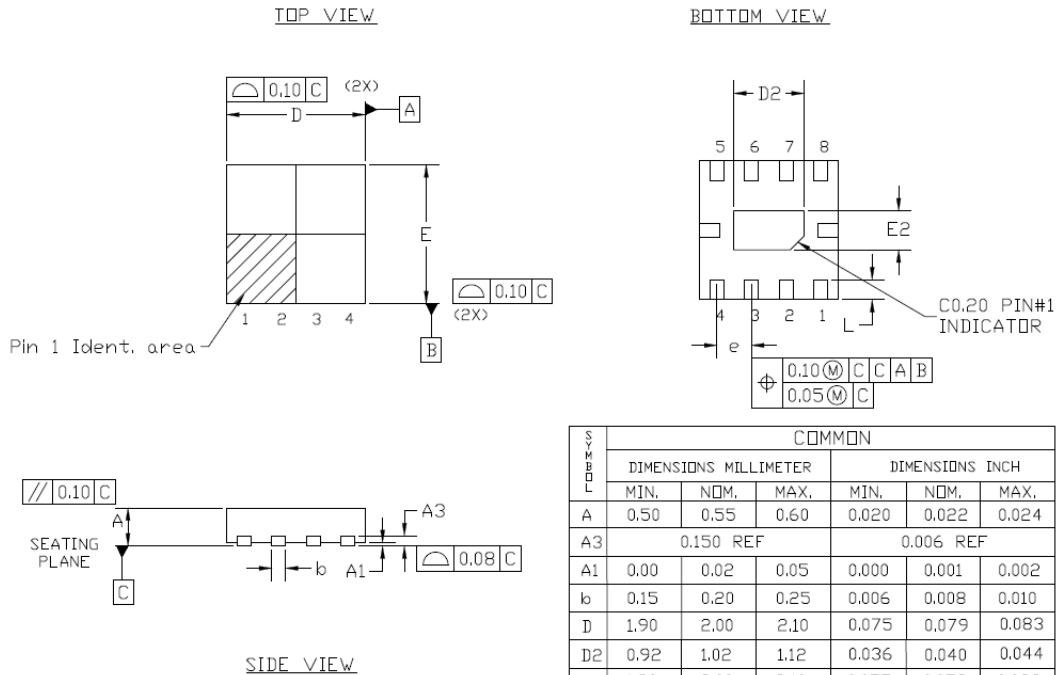

SYMBOL	COMMON					
	DIMENSIONS MILLIMETER			DIMENSIONS INCH		
	MIN.	NOM.	MAX.	MIN.	NOM.	MAX.
A	0.50	0.55	0.60	0.020	0.022	0.024
A3	0.150 REF			0.006 REF		
A1	0.00	0.02	0.05	0.000	0.001	0.002
b	0.15	0.20	0.25	0.006	0.008	0.010
D	1.90	2.00	2.10	0.075	0.079	0.083
D2	0.92	1.02	1.12	0.036	0.040	0.044
E	1.90	2.00	2.10	0.075	0.079	0.083
E2	0.46	0.56	0.66	0.018	0.022	0.026
e	0.50 BSC			0.020 BSC		
L	0.24	0.29	0.30	0.010	0.011	0.012

NOTES :

1. DIMENSION AND TOLERANCING CONFORM TO ASME Y14.5M-1994.
2. CONTROLLING DIMENSIONS : MILLIMETER, CONVERTED INCH DIMENSION ARE NOT NECESSARILY EXACT.

Suggested PCB Land Pattern and PAD Layout

PCB Land Pattern

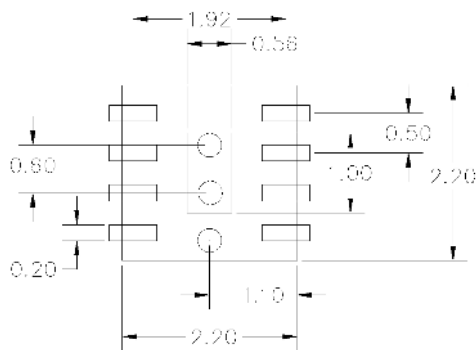

Note : All dimension _ millimeters

PCB lay out _ on BeRex website

PCB Mounting

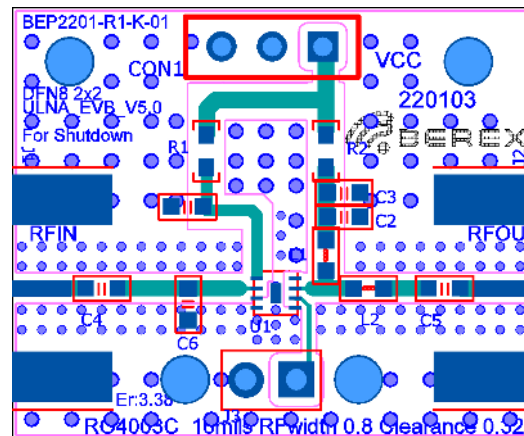

2500 – 5000 MHz High Linearity LNA

Package Marking



Pin 1

XX = Wafer No.

Tape & Reel

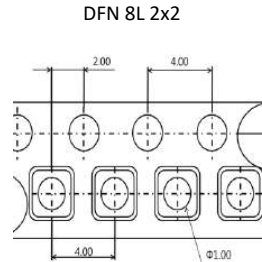

DFN 8L 2x2

Packaging information:

Tape Width (mm): 8

Reel Size (inches): 7

Device Cavity Pitch (mm): 4

Devices Per Reel: 3000

Lead plating finish

100% Tin Matte finish

(All BeRex products undergoes a 1 hour, 150 degree C, Anneal bake to eliminate thin whisker growth concerns.)

MSL / ESD Rating

ESD Rating: Class 1C

Value: Passes $\geq 1000V$ to $< 2000 V$

Test: Human Body Model (HBM)

Standard: JEDEC Standard JS-001-2017

ESD Rating: Class C2

Value: Passes $\geq 500V$ to $< 1000 V$

Test: Charged Device Model (CDM)

Standard: JEDEC Standard JS-002-2018

MSL Rating: Level 1 at $+260^{\circ}C$ convection reflow

Standard: JEDEC Standard J-STD-020



Proper ESD procedures should be followed when handling this device.

2500 – 5000 MHz High Linearity LNA

RoHS Compliance

This part is compliant with Restrictions on the Use of Certain Hazardous Substances in Electrical and Electronic Equipment (RoHS) Directive 2011/65/EU as amended by Directive 2015/863/EU.

This product also is compliant with a concentration of the Substances of Very High Concern (SVHC) candidate list which are contained in a quantity of less than 0.1%(w/w) in each components of a product and/or its packaging placed on the European Community market by the BeRex and Suppliers.

NATO CAGE code:

2	N	9	6	F
---	---	---	---	---