

Features and Benefits

PTC04 interface board for testing devices:

- MLX90288
- MLX91206
- MLX91207
- MLX90291
- MLX90292 for 3 wire PWM

Applications

Experimental tool for Lab and Prototyping
 Production Equipment for Serial Programming

Ordering Information

Part No.	Description
PTC04-DB-HALL03 V1.1	Daughter Board (PCB + rear panel PTC04)

Accessories

Part No.	Description
DLL's for all supported products	
User Interfaces for supported products	
Firmware for supported products	

1. Functional Diagram

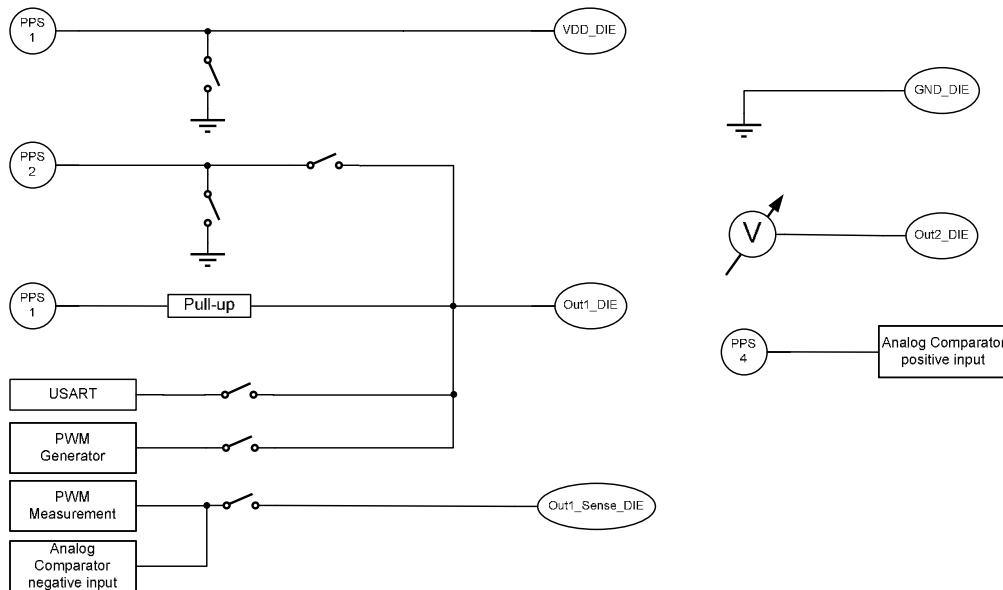
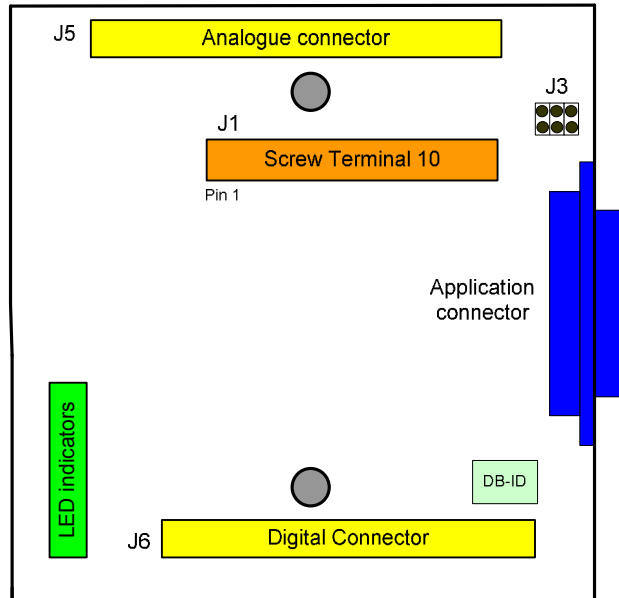

TABLE OF CONTENTS

FEATURES AND BENEFITS	1
APPLICATIONS.....	1
ORDERING INFORMATION.....	1
ACCESSORIES	1
1. FUNCTIONAL DIAGRAM.....	1
2. BOARD DESCRIPTION	3
2.1. BOARD LAYOUT.....	3
2.2. BOARD SCHEMATICS.....	4
2.3. DAUGHTER BOARD CONNECTORS	5
2.3.1. <i>Digital DB Connector (40 Pins)</i>	5
2.3.2. <i>Analog DB Connector (48 Pins)</i>	6
2.4. APPLICATION CONNECTOR.....	6
2.4.1. <i>The DB15_Female connector (application connector)</i>	6
2.4.2. <i>The screw terminal</i>	7
3. DISCLAIMER.....	8

2. Board description

2.1. Board Layout



- J3: Jumpers to connect the measurement sense lines immediately to the force lines. These jumpers are needed when no force and sense is used.
- DB-ID: This ID keeps a few initial variables in mind. It allows for example to detect what DB is connected to the programmer and if the DB is not expired.
- J5, J6: Analogue and Digital connector: See below for a detailed description.
- DB Connector: Connector to the application. See below for details.
- LED Indicators: 8 LED Indicators for the DB_IODrv lines.
- J1: 10 pins Screw Terminal. It provides the same signals as the application connector.

2.2. Board Schematics

Below you can find the complete schematics of the DB:

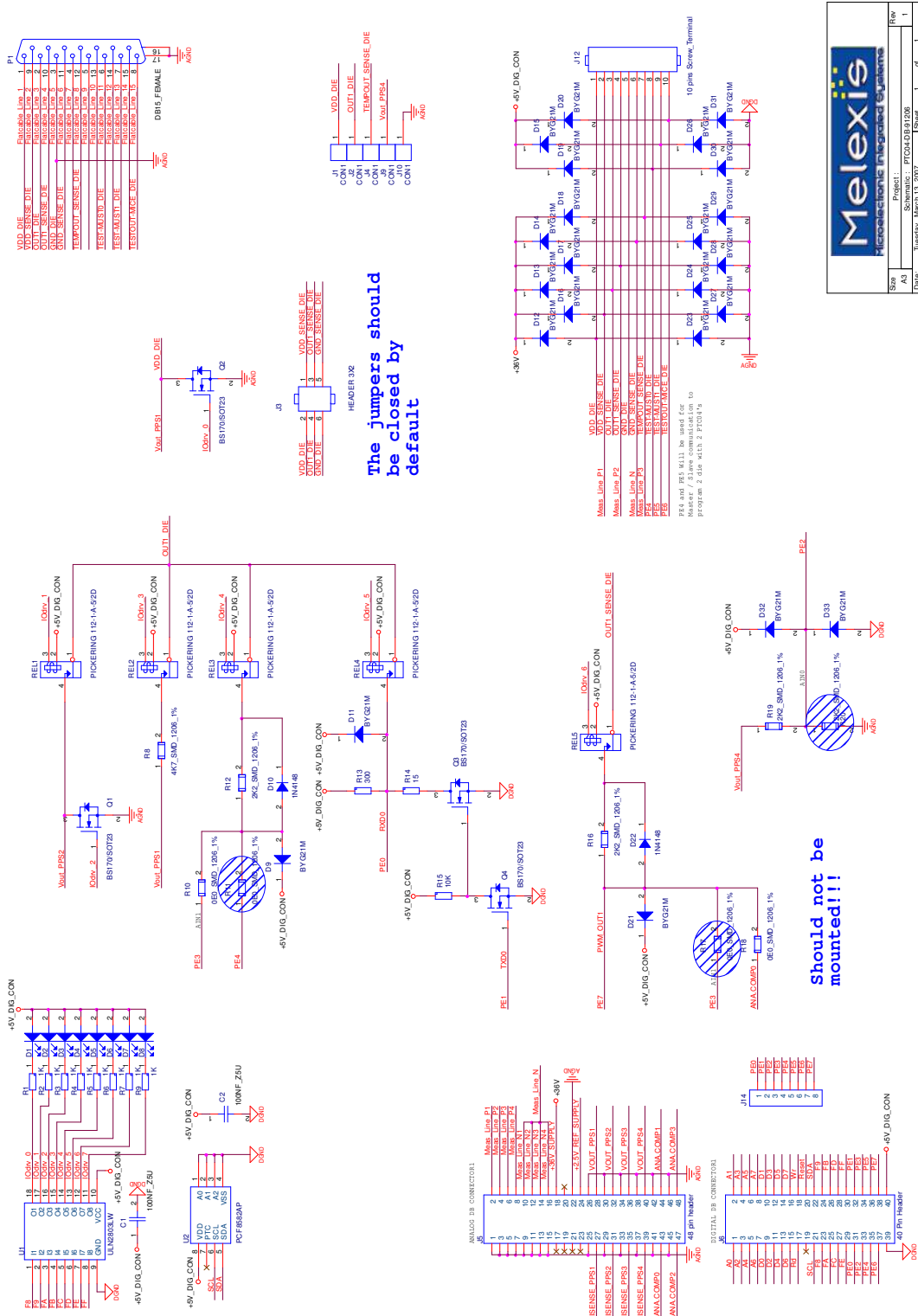

2.3. Daughter board Connectors

The PTC04 main board has two connectors to the interface with the application. The PTC allows adding a full PCB in between (Daughter Board). This daughter board can be mounted on the two connectors. In some exceptional cases, a daughter board contains only a few wires from the Analogue connector to the application connector. The pins on of the connectors are described below.

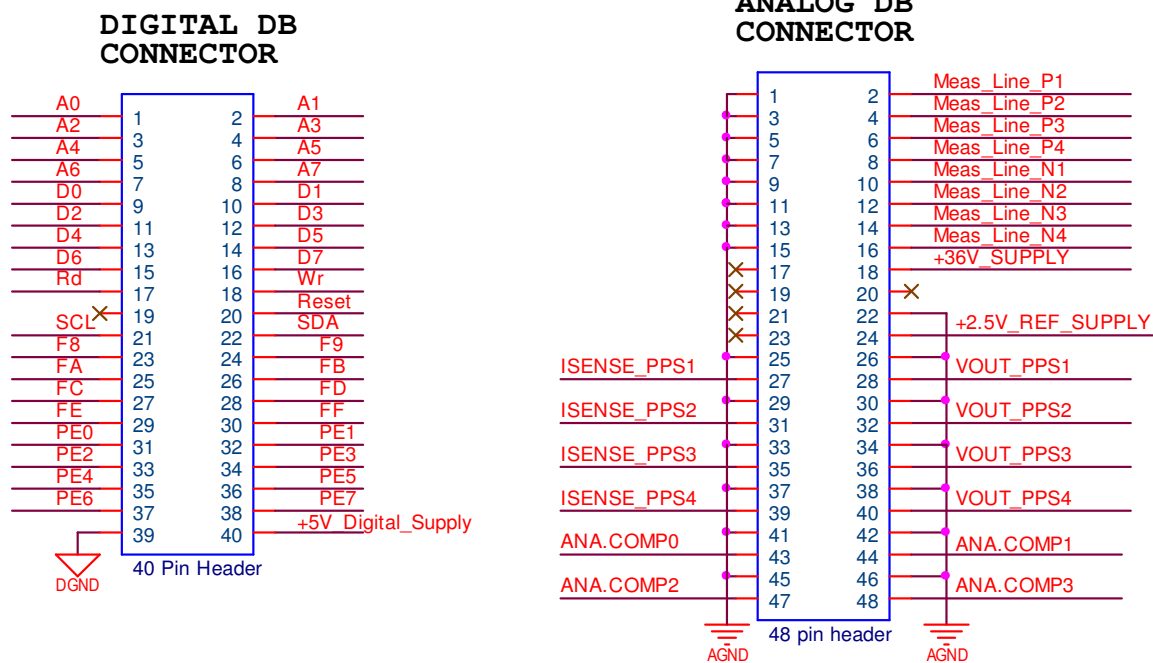

2.3.1. Digital DB Connector (40 Pins)

Mainly, the digital connector is meant to expand the programmer to extra needs. Address lines A0-A7 together with the Map Select Lines F8-FF allows to direct access an area of 2 K. Examples would be adding a simple addressed I/O register by using the selection lines. If more complexity is needed, a full FPGA can be mounted on the DB board

Pins	Names	Description
1 – 8	A0 – A7	Address lines
9 – 16	D0 – D7	Data Lines active during Rd or Wr signals
17	Rd	Read: A negative pulse will indicate a sampling of the data on the Data Bus
18	Wr	Write: A Negative pulse will indicate when data is available on the Data Bus
20	Reset	This signal goes low by powering the PTC or by pressing the reset button. This line can be pulled low by application. Check firmware documentation for resetting by software.
21-22	SCL / SDA	I ² C Bus
23-30	F8,F9,...,FF	CS lines when the address areas are accessed
31-38	Port E	Note: These pins are limited to 5 Volt input/output!!! The full Port E of the Atmega core is mounted to these pins. This allows us to use advanced features like PWM, UARTS, Time Measurements, etc.... By using firmware that supports these, functions, application specific requirements can be fulfilled.
39	DGND	Digital Ground
40	+5V Digital	5 Volt Digital Supply. Maximum current to get out of this supply : 250mA

Note: All the pins are limited to 5 Volt input/output!!! However, there are Protections, please take precautions in order to avoid damage of the main board.

2.3.2. Analog DB Connector (48 Pins)

Mainly, the analog connector provides all the analog signals and measure possibilities.

Pins	Names	Description
28,32,36	PPS 1-3	Output of the high current Programmable Supplies
40	PPS 4	Output of the Fast DAC Programmable Power Supply
27,31,35,39	Isense_PP1-4	Outputs (Driver outputs before Rsens) for current evaluations. These outputs could be used to connect to the analog comparators in order to create fast digital signals based on current.
2,4,6,8	ExtMeas1-4Pos	There are 4 differential inputs for making measurements, these are the positive inputs.
10,12,14,16	ExtMeas1-4Neg	The negative inputs of ExtMeas1- 4Pos
43,44,47,48	AnaComp0-3	Input (limited to +5V) See *Note. Fast Level comparators in order to remove time consuming measurement
18	+35V_Supply	Supply to extend the daughter board with some extra drivers
24	+2.5V_Ref	Output of internal reference
All other	AGND	Analogue Ground

Note: All the pins are limited to 35 Volt input/output!!! However, there are protections, please take precautions in order to avoid damage of the main board.

* Note: Some pins are protected and limited to 5 Volt!!! However, there are Protections, please take precautions in order to avoid damage of the main board.

2.4. Application Connector

There are two ways to connect the application to PTC04:

2.4.1. The DB15_Female connector (application connector)

DB15 Female Connector

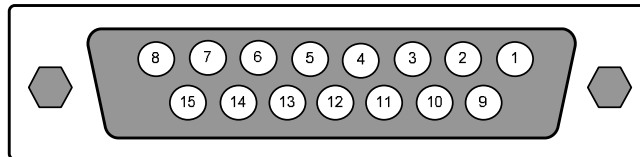

Pins	Names	Description
1	VDD_DIE	Device Supply
2	OUT1_DIE	Device Output 1
3	GND_DIE	Analogue Ground
4	NC	Not Connected
5	NC	Not Connected
6	TEST_MUST0_DIE	Digital test pin – MUST0 (if Master-Slave approach used acts as M2S)
7	TEST_MUST1_DIE	Digital test pin – MUST1 (if Master-Slave approach used acts as S2M)
8	TESTOUT_MICE_DIE	Digital test pin – MICE
9	VDD_SENSE_DIE	Sensing Device Supply
10	OUT1_SENSE_DIE	Sensing Device Output 1
11	GND_SENSE_DIE	Sensing Analogue Ground Device
12	OUT2_DIE	Device Output 2 (TempOut)
13	NC	Not Connected
14	NC	Not Connected
15	NC	Not Connected

2.4.2. The screw terminal

10 Pin Screw Terminal

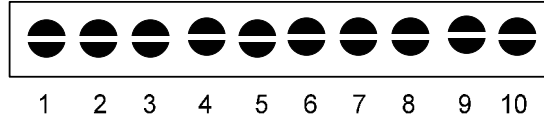

Pins	Names	Description
1	VDD_DIE	Device Supply
2	VDD_SENSE_DIE	Sensing Device Supply
3	OUT1_DIE	Device Output 1
4	OUT1_SENSE_DIE	Sensing Device Output 1
5	GND_DIE	Analogue Ground Device
6	GND_SENSE_DIE	Sensing Analogue Ground Device
7	OUT2_DIE	Device Output 2 (TempOut)
8	TEST_MUST0_DIE	Digital test pin – MUST0 (if Master-Slave approach used acts as M2S)
9	TEST_MUST1_DIE	Digital test pin – MUST1 (if Master-Slave approach used acts as S2M)
10	TESTOUT_MICE_DIE	Sensing Analogue Ground Device

3. Disclaimer

Devices sold by Melexis are covered by the warranty and patent indemnification provisions appearing in its Term of Sale. Melexis makes no warranty, express, statutory, implied, or by description regarding the information set forth herein or regarding the freedom of the described devices from patent infringement. Melexis reserves the right to change specifications and prices at any time and without notice. Therefore, prior to designing this product into a system, it is necessary to check with Melexis for current information. This product is intended for use in normal commercial applications. Applications requiring extended temperature range, unusual environmental requirements, or high reliability applications, such as military, medical life-support or life-sustaining equipment are specifically not recommended without additional processing by Melexis for each application.

The information furnished by Melexis is believed to be correct and accurate. However, Melexis shall not be liable to recipient or any third party for any damages, including but not limited to personal injury, property damage, loss of profits, loss of use, interrupt of business or indirect, special incidental or consequential damages, of any kind, in connection with or arising out of the furnishing, performance or use of the technical data herein. No obligation or liability to recipient or any third party shall arise or flow out of Melexis' rendering of technical or other services.

© 2011 Melexis NV. All rights reserved.

For the latest version of this document, go to our website at
www.melexis.com

Or for additional information contact Melexis Direct:

Europe, Africa, Asia:
Phone: +32 1367 0495
E-mail: sales_europe@melexis.com

America:
Phone: +1 603 223 2362
E-mail: sales_usa@melexis.com

ISO/TS 16949 and ISO14001 Certified