

ZL9101EVAL1Z

Digital DC/DC 12A Module Evaluation Board

AN1625  
Rev 0.00  
February 4, 2011

**Description**

The ZL9101M is a 12A variable output, step-down power supply module. Included in the module is a high-performance digital PWM controller, power MOSFETs, an inductor, and all the passive components required for a complete DC/DC power solution. The ZL9101M operates over a wide input voltage range and supports an output voltage range of 0.6V to 4V, which can be set by external resistors or via the PMBus. This high-efficiency power module is capable of delivering 12A. Only bulk input and output capacitors are needed to finish the design. The output voltage can be precisely regulated to as low as 0.6V with  $\pm 1\%$  output voltage regulation.

The ZL9101EVAL1Z is a 6-layer board that provides a single-phase power rail up to 12A loads. The board is designed to efficiently transfer heat away from the module with passive cooling.

A USB to SMBus adapter is used to connect the ZL9101EVAL1Z board to a PC. The PMBus command set is accessed by using the PowerNavigator™ evaluation software.

**Key Features**

- Complete Switch Mode Power Supply
- 12A DC Output Current
- Adjustable +0.6V to +4V Output Range
- Up to 90% Efficiency
- Digital Control PWM
- Fixed 615kHz Switching Frequency
- Fast Transient Response
- Enable Function Option
- Power-Good Indicator
- Convenient Power Connection
- Multiple Power Options
- Single Supply Operation
- Configurable Through SMBus

**Key Specifications**

The ZL9101EVAL1Z has been designed and optimized for the following parameters:

- $V_{IN} = 12V$
- $V_{OUT} = 1.2V$
- $I_{OUT(MAX)} = 15A$
- $F_{SW} = 615kHz$
- $V_{OUT(RIPPLE)} < 1\%$
- Transient Response = 3% (3A to 9A step at 2.5V/ $\mu s$ )

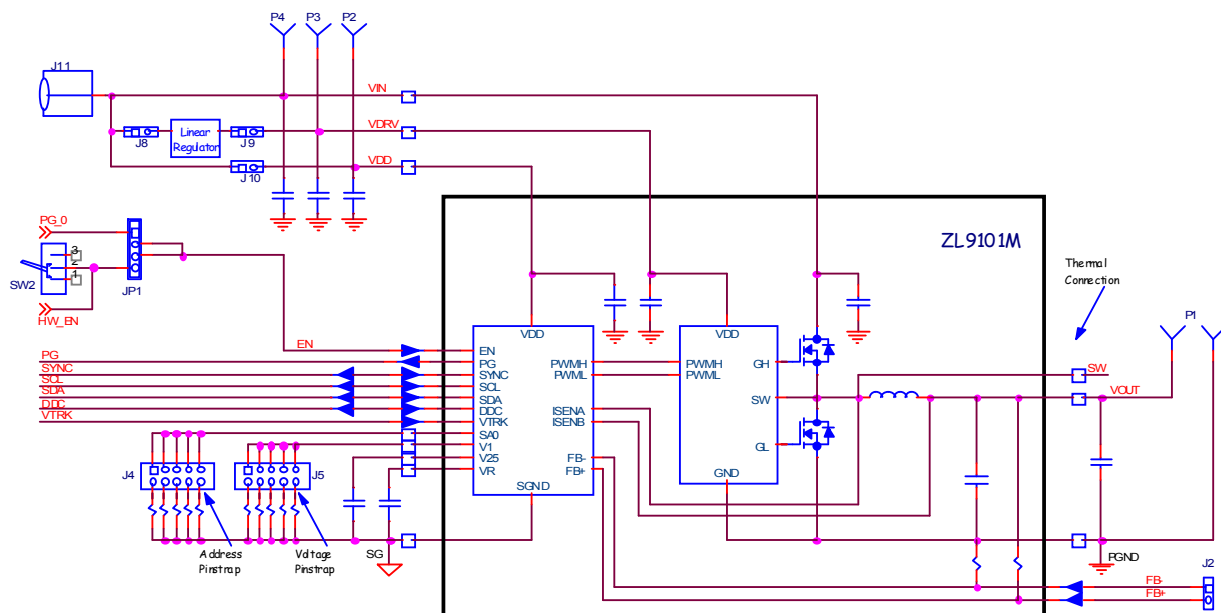

FIGURE 1. ZL9101EVAL1Z EVALUATION BOARD BLOCK DIAGRAM

## Functional Description

The ZL9101EVAL1Z evaluation board provides all the circuitry required to evaluate the features of the ZL9101M module. The ZL9101EVAL1Z has a performance-optimized, single-phase ZL9101M circuit layout that allows operation up to the maximum rated output current. Power options and load connections are provided through plug-in sockets and shorting jumpers.

Figure 1 shows a functional block diagram of the ZL9101EVAL1Z board. The SMBus address is selectable through J4 located on the top side of the board. All power to the board ( $V_{IN}$  and  $I^2C$  bus) must be removed before changing the jumpers.

The hardware enable function is controlled by a toggle switch on the ZL9101EVAL1Z board. The power-good (PG) LED indicates the state of PG when external power is applied to the ZL9101EVAL1Z board. The right-angle headers at opposite ends of the board are for connecting a USB to an SMBus adapter board or for daisy-chaining of multiple evaluation boards.

Figure 2 shows the ZL9101EVAL1Z operational circuit. The circuit consists of the ZL9101M module and supporting components.

Figure 3 shows the ZL9101EVAL1Z interface schematic.

Figures 4 through 9 show the layers of the ZL9101EVAL1Z evaluation board.

### Basic Operation

The ZL9101EVAL1Z evaluation board is easy to set up and operate. It is optimally configured, out of the box, to provide 1.2V at 12A from a 12V source. All input and output connections should be made before applying power.

The ZL9101M module requires a configuration file in order to operate. The ZL9101M supports pinstrap configuration for output voltage and SMBus address. All other parameters must be configured with a text-based configuration file. See application note [AN2031](#) for more information on writing configuration files. An example configuration file is listed at the end of this document.

### Pinstraps

The ZL9101M requires a configuration file for normal operation; however, there are two pinstrap functions to be configured: Voltage and SMBus address. Ensure that input power is removed, and then set the address and voltage pinstraps using J4 and J6. Apply  $V_{DD}$  power, and the new settings will be in effect.

### PMBus Operation

The ZL9101M utilizes the PMBus protocol. The PMBus functionality can be controlled via USB from a PC running the PowerNavigator™ evaluation software in a Windows XP or Windows 2000/NT operating system.

Install the PowerNavigator™ software using the CD included in the ZL9101EVAL1Z kit. For PMBus operation, connect the USB-to-SMBus dongle board to J7 of the ZL9101EVAL1Z board. Connect the desired load and an appropriate power supply to the input. Place the ENABLE switch in “DISABLE” and turn on the power. The PowerNavigator™ evaluation software allows modification of all ZL9101M PMBus parameters. See Application Note [AN2033](#) for PMBus command details. Use the mouse-over pop-ups for PowerNavigator™ help. Manually configure the ZL9101M through

PowerNavigator™ or load a predefined scenario from a configuration file.

The ENABLE switch can then be moved to “ENABLE” and the ZL9101M can be tested. Alternately, the PMBus ONOFF, CONFIG, and OPERATION commands can be used.

### Single-Supply Operation

The ZL9101EVAL1Z board was designed to facilitate operation from a single power supply input. The single input power mode reduces the number of connections but results in a minor reduction of efficiency.

The driver bias is supplied by an onboard linear regulator. Figure 3 shows the onboard regulator circuit for powering the ZL9101M driver. Jumpers J8 and J9 connect the supply power to the linear regulator that is used to power the driver, and J6 connects input power to the ZL9101M digital module. If single-supply operation is desired, J6, J8, and J9 must be installed.

### Multi-Supply Operation (External Driver Supply)

To operate the ZL9101EVAL1Z driver from an external power supply, remove J8 and J9, and connect an external power supply to the driver connector, P3, between 4.5V to 6.5V.

To operate the ZL9101EVAL1Z board using different power supplies for the controller and FETs, remove J6 and apply an external power supply to power the FETs to P4 to between 3.0V and 14V.

Apply a power supply voltage to the ZL9101M module through the P2 connector.

If the  $V_{DD}$  voltage is  $4.5V \leq V_{DD} \leq 5.5V$ , then apply 4.5V to 5.5V to P2, and connect  $V_R$  to  $V_{DD}$ . Do not exceed 5.5V while  $V_R$  is connected to  $V_{DD}$  or permanent damage will result.

If the  $V_{DD}$  voltage is  $5.5V \leq V_{DD} \leq 14V$ , then apply 5.5V to 14V to P2, and do not connect to  $V_R$ .

The ZL9101EVAL1Z comes configured to use hardware Enable. Toggle the power switch to the Enable position to power on. Use the GUI to change the configuration, if desired.

### Power Good

The ZL9101M provides a Power-Good (PG) signal, which indicates that the output voltage is within a specified tolerance of its target level and that no fault condition exists. By default, the PG pin asserts if the output is within 10% of the target voltage. These limits and the polarity of the pin may be changed via the  $I^2C$ /SMBus interface. See Application Note [AN2033](#) for details.

A PG delay period is defined as the time from when all conditions within the ZL9101M for asserting PG are met to when the PG pin is actually asserted. This feature is commonly used instead of using an external reset controller to control external digital logic. By default, the ZL9101M PG delay is set equal to the soft-start ramp time setting of 10ms. The PG delay may be set independently of the soft-start ramp by using the  $I^2C$ /SMBus as described in Application Note [AN2033](#).

## Switching Frequency and PLL

The ZL9101M incorporates an internal phase-locked loop (PLL) to clock the internal circuitry. The PLL can be driven by an external clock source connected to the SYNC pin via J7 or J14. When using the internal oscillator, the SYNC pin can be configured as a clock source.

The internal switching frequency of the ZL9101M is 615kHz. Operation below 615kHz will increase the inductor ripple current and cause permanent damage.

## Loop Compensation

The ZL9101M operates as a voltage-mode synchronous buck controller with a fixed frequency PWM scheme. The module is internally compensated via the I<sup>2</sup>C/SMBus interface. The PID settings are included in the configuration file stored on the ZL9101M; the settings are shown in “Default Configuration File” on page 6 for reference. The compensation tool, CompZL™ can be used to generate appropriate PID settings for other circuit configurations.

## Adaptive Diode Emulation

Adaptive diode emulation mode turns off the low-side FET gate drive at low load currents to prevent the inductor current from going negative, thus reducing energy losses and increasing overall efficiency. Diode emulation is available to single-phase devices only.

NOTE: The overall bandwidth of the device may be reduced when in diode emulation mode. It is recommended that diode emulation be disabled prior to applying significant load steps.

## Input Undervoltage Lockout

The input undervoltage lockout (UVLO) prevents the ZL9101M from operating when the input falls below a preset threshold, indicating the input supply is out of its specified range. The UVLO threshold ( $V_{UVLO}$ ) can be set between 2.85V and 16V using the I<sup>2</sup>C/SMBus interface.

Once an input undervoltage fault condition occurs, the device can respond in a number of ways as follows:

1. Continue operating without interruption.
2. Continue operating for a given delay period, followed by shutdown if the fault still exists. The device remains in shutdown until instructed to restart.

## Connectors and Jumpers

Connector and jumpers are shown in Figure 10.

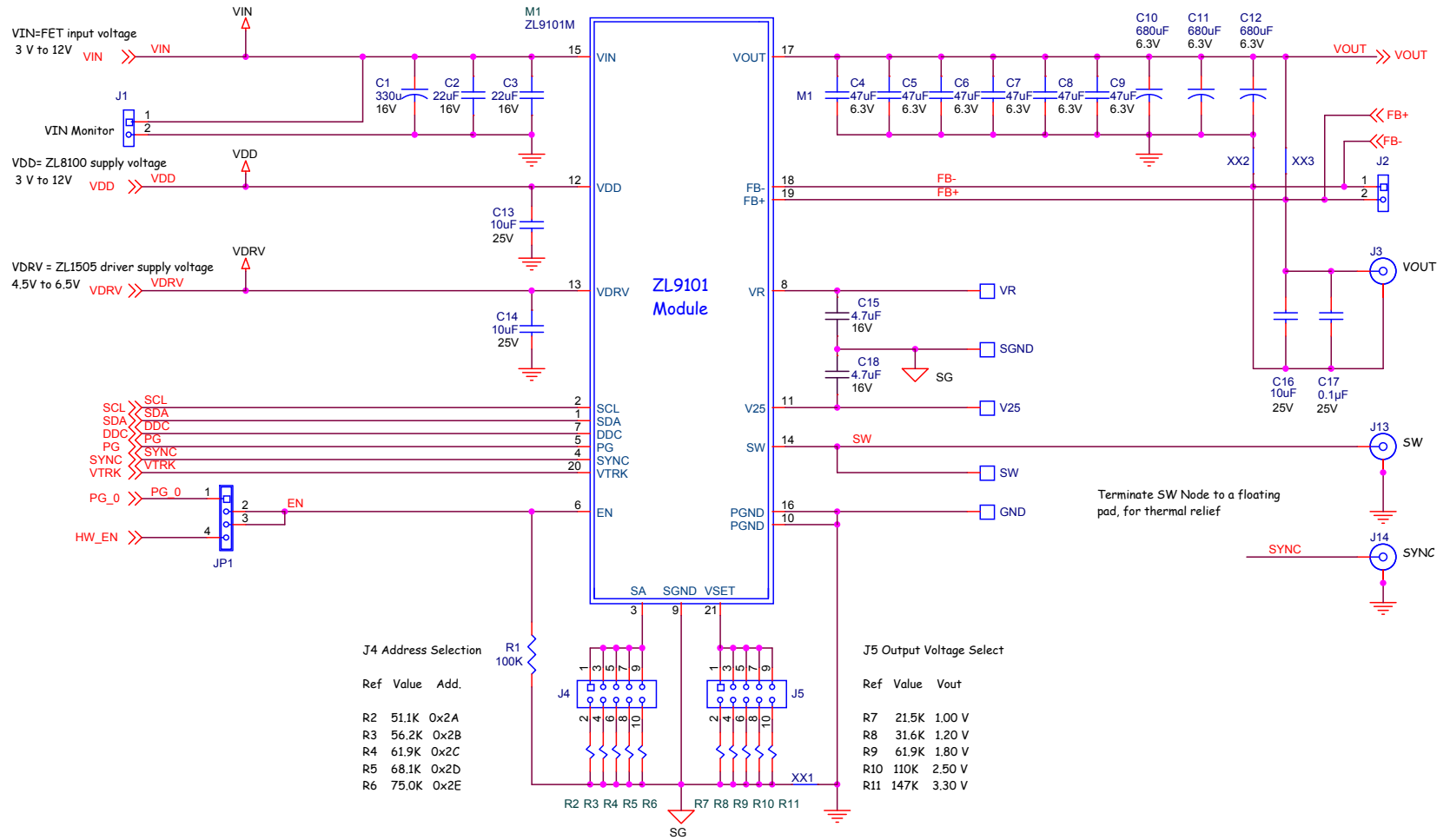

FIGURE 2. ZL9101EVAL1Z CIRCUIT SCHEMATIC

# Module Interface

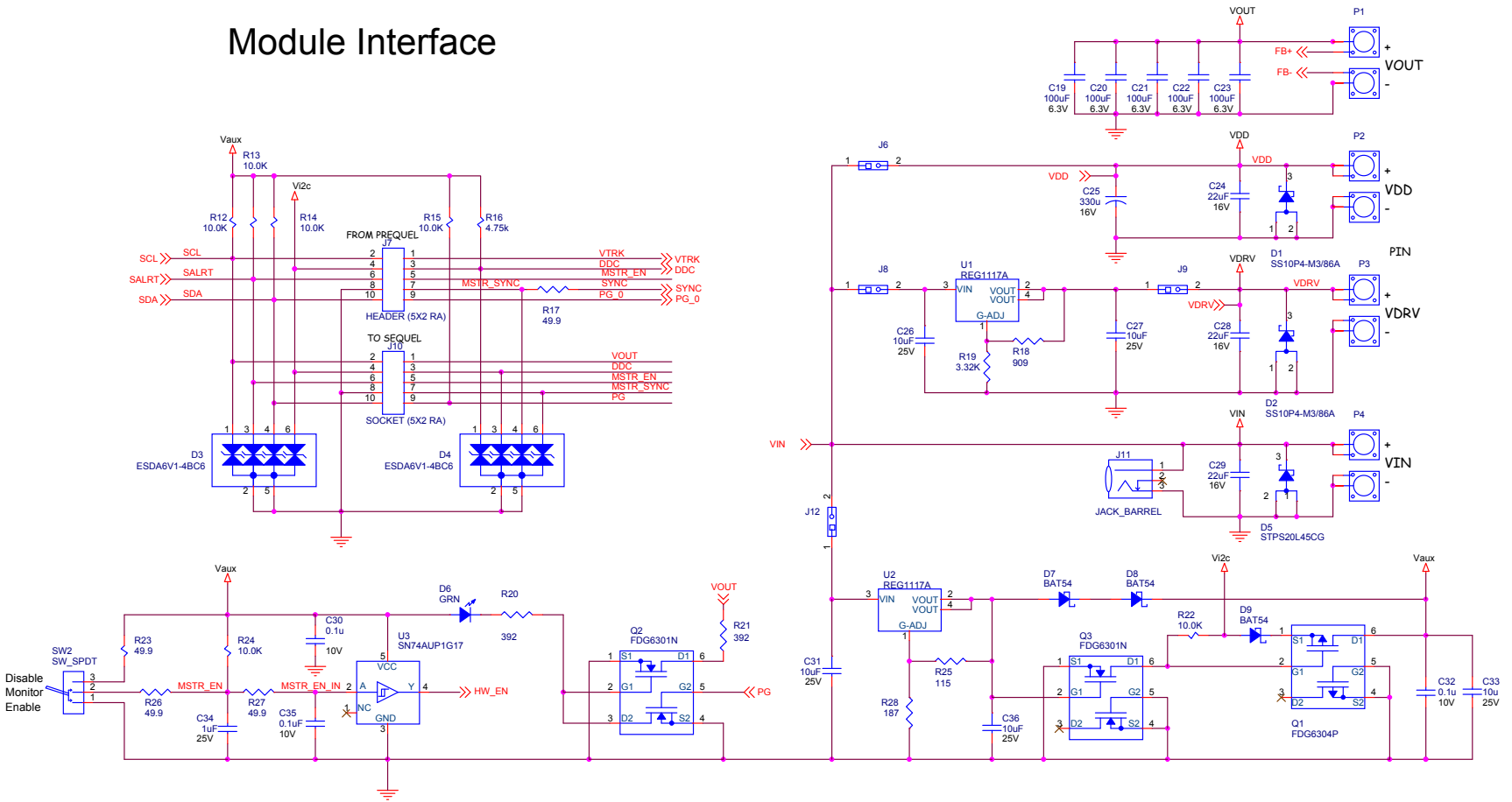

FIGURE 3. ZL9101EVAL12 INTERFACE SCHEMATIC

## Default Configuration File

The following text is loaded into the ZL9101M devices on the ZL9101EVAL1Z evaluation board as the default settings. This configuration file can be loaded using the PowerNavigator™ software, ConfigCheck™ software, or a user-created application. The # symbol denotes a comment line.

```
# Intersil ZL9101M 12/20/2010
# ZL Configuration File Revision 2
# Schematic revision level
# BOM revision level
# ZL Author
# Change log:
```

```
RESTORE_FACTORY
STORE_DEFAULT_ALL
STORE_USER_ALL
RESTORE_DEFAULT_ALL
```

```
MFR_ID           Intersil
MFR_MODEL        ZL9101EVAL1Z
MFR_REVISION     REV_2.0
MFR_LOCATION     Austin
MFR_DATE         12_20_2010
MFR_SERIAL       1p2V_15A
ON_OFF_CONFIG    0x1A
#VOUT_COMMAND
#VOUT_OV_FAULT_LIMIT
#VOUT_MAX
#VOUT_UV_FAULT_LIMIT
#VOUT_MARGIN_HIGH
#VOUT_MARGIN_LOW
#VOUT_DROOP
#POWER_GOOD_ON   5
#POWER_GOOD_DELAY 5
IOUT_SCALE       1.556
IOUT_CAL_OFFSET  -2.30
TON_DELAY        5
TON_RISE         5
TOFF_DELAY       5
TOFF_FALL        5
FREQUENCY_SWITCH 615
VOUT_OV_FAULT_RESPONSE 0x80
VOUT_UV_FAULT_RESPONSE 0x80
OVUV_CONFIG      0x80
IOUT_OC_FAULT_LIMIT 25
IOUT_AVG_OC_FAULT_LIMIT 25
```

---

IOUT_UC_FAULT_LIMIT	-20
IOUT_AVG_UC_FAULT_LIMIT	-20
MFR_IOUT_OC_FAULT_RESPONSE	0x80
MFR_IOUT_UC_FAULT_RESPONSE	0x80
MFR_VMON_OV_FAULT_LIMIT	7.0
VMON_OV_FAULT_RESPONSE	0x80
MFR_VMON_UV_FAULT_LIMIT	4.5
VMON_UV_FAULT_RESPONSE	0x80
VIN_OV_WARN_LIMIT	14.3
VIN_OV_FAULT_LIMIT	14.5
VIN_OV_FAULT_RESPONSE	0x80
VIN_UV_WARN_LIMIT	4.2
VIN_UV_FAULT_LIMIT	4.0
VIN_UV_FAULT_RESPONSE	0x80
OT_WARN_LIMIT	110.0
OT_FAULT_LIMIT	125
OT_FAULT_RESPONSE	0x80
UT_WARN_LIMIT	-20
UT_FAULT_LIMIT	-40
UT_FAULT_RESPONSE	0x00
PID_TAPS	A=16133.25, B=-27119.00, C=10998.50
DEADTIME	0x3838
DEADTIME_CONFIG	0x8C06
DEADTIME_MAX	0x2828
MAX_DUTY	92
#TRACK_CONFIG	
#XTEMP_SCALE	1.0
#XTEMP_OFFSET	10.0
MFR_CONFIG	0x8311
NLR_CONFIG	0x00000000
USER_CONFIG	0x0031
TEMPCO_CONFIG	0x28
MISC_CONFIG	0x8880
ISHARE_CONFIG	0x0000
INTERLEAVE	0x0000
SEQUENCE	0x0000
DDC_GROUP	0x00000000
DDC_CONFIG	0x0000
INDUCTOR	0.30
STORE_DEFAULT_ALL	
RESTORE_DEFAULT_ALL	

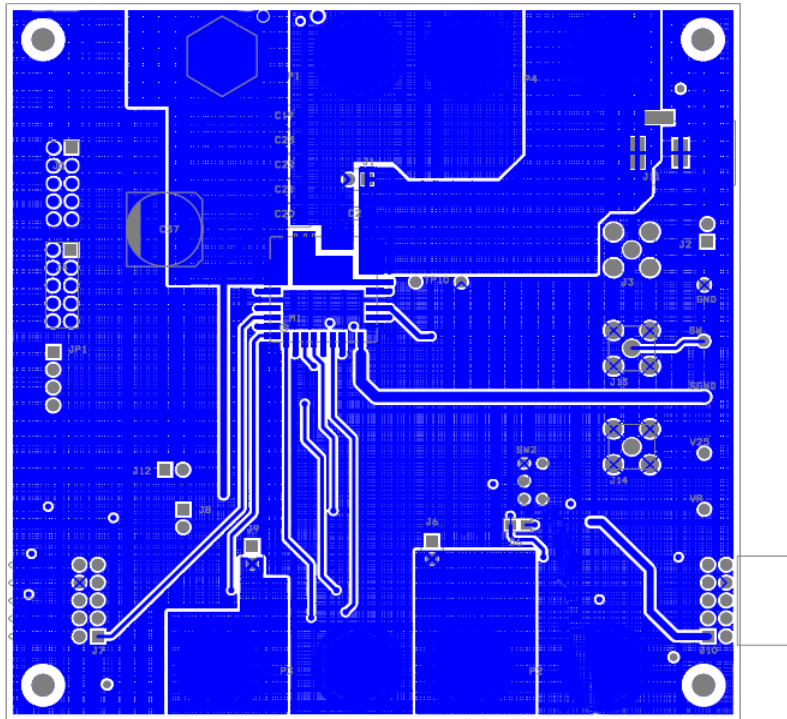

FIGURE 4. TOP LAYER

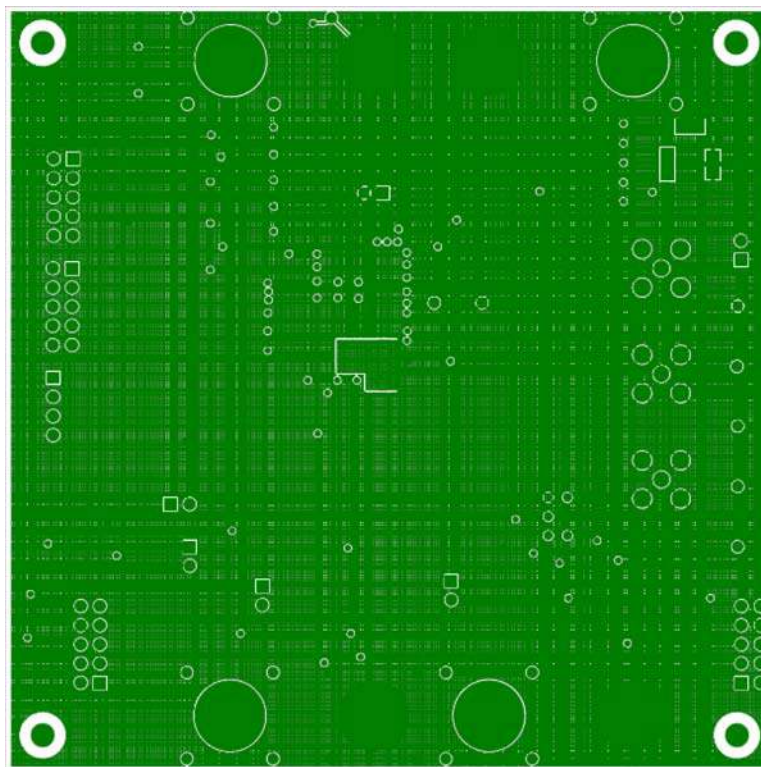
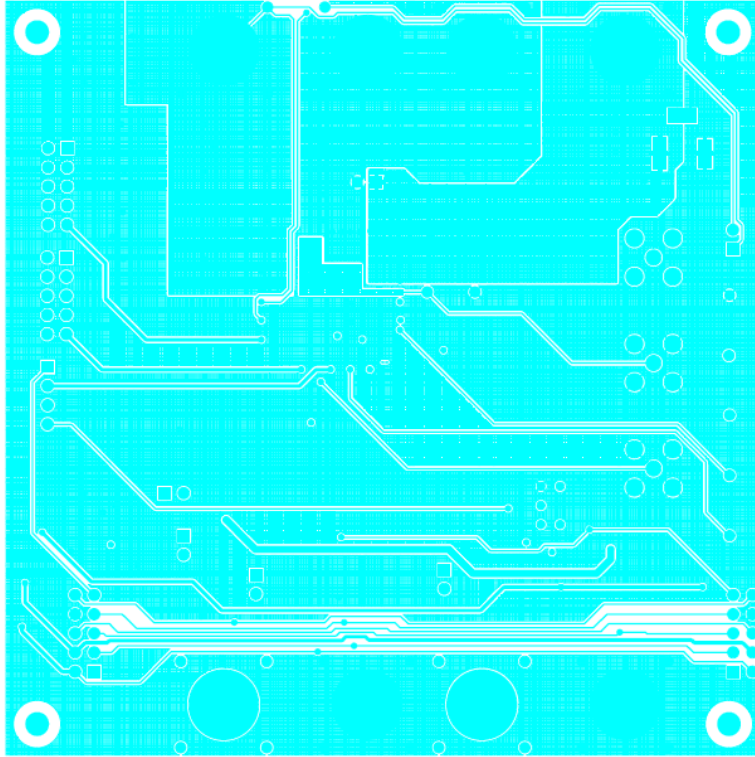
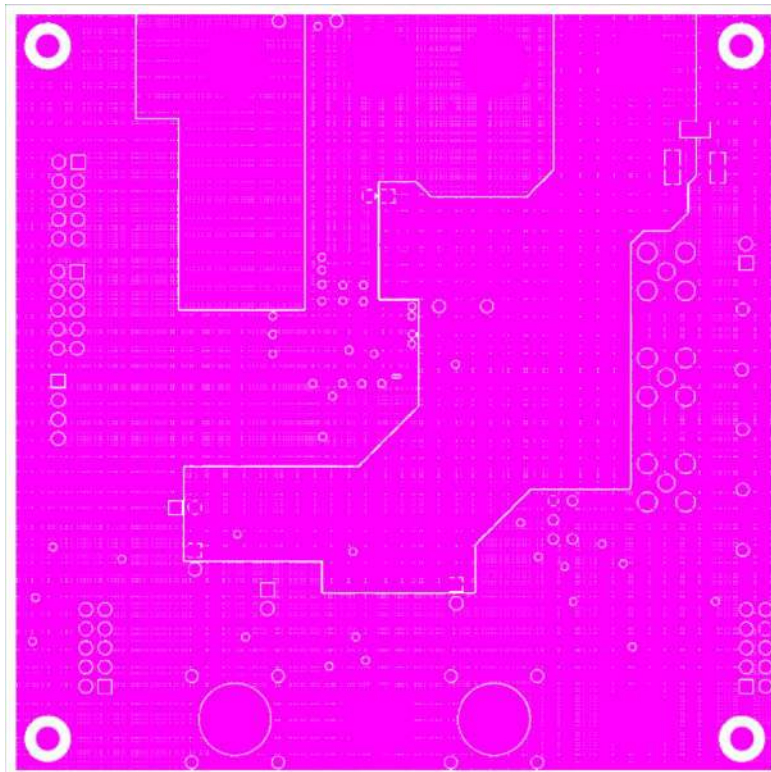

FIGURE 5. INNER\_1





**FIGURE 6. INNER\_2**



**FIGURE 7. INNER\_3**

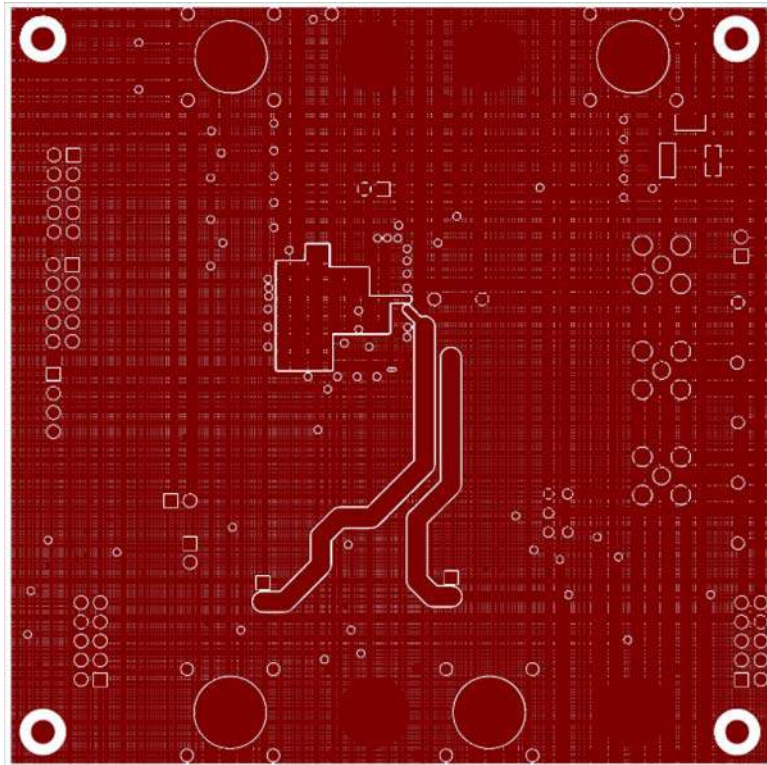

FIGURE 8. INNER\_4

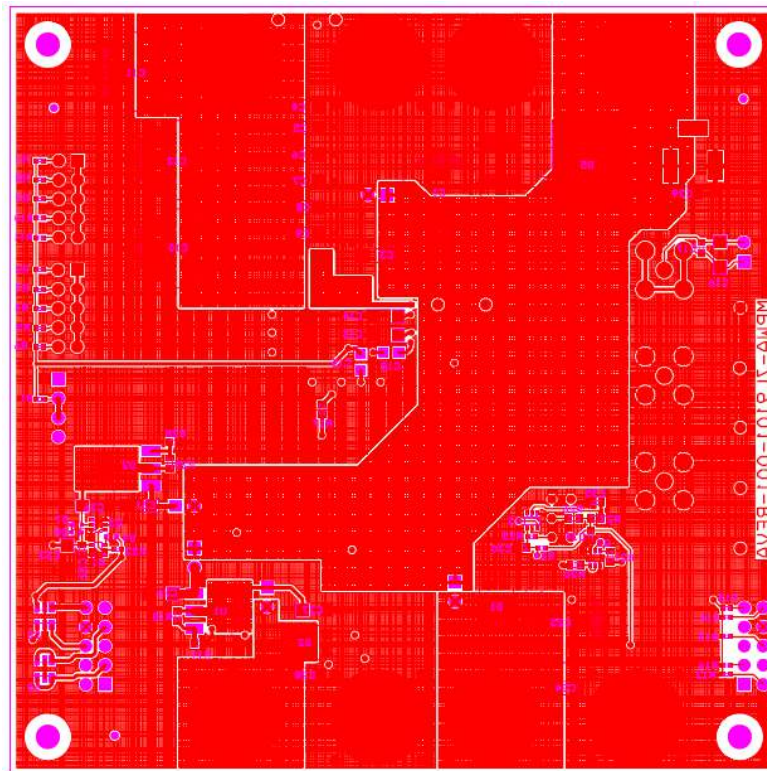

FIGURE 9. BOTTOM

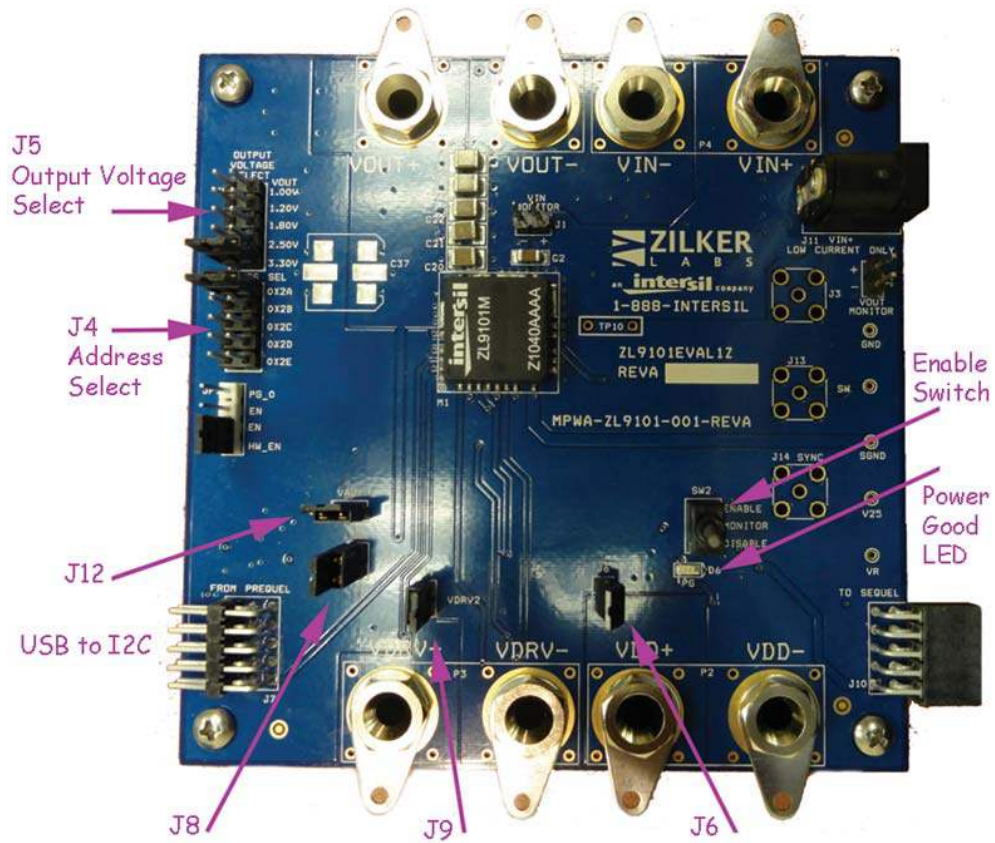

FIGURE 10. PHOTO SHOWING JUMPERS AND CONNECTORS

## Notice

1. Descriptions of circuits, software and other related information in this document are provided only to illustrate the operation of semiconductor products and application examples. You are fully responsible for the incorporation or any other use of the circuits, software, and information in the design of your product or system. Renesas Electronics disclaims any and all liability for any losses and damages incurred by you or third parties arising from the use of these circuits, software, or information.
2. Renesas Electronics hereby expressly disclaims any warranties against and liability for infringement or any other claims involving patents, copyrights, or other intellectual property rights of third parties, by or arising from the use of Renesas Electronics products or technical information described in this document, including but not limited to, the product data, drawings, charts, programs, algorithms, and application examples.
3. No license, express, implied or otherwise, is granted hereby under any patents, copyrights or other intellectual property rights of Renesas Electronics or others.
4. You shall not alter, modify, copy, or reverse engineer any Renesas Electronics product, whether in whole or in part. Renesas Electronics disclaims any and all liability for any losses or damages incurred by you or third parties arising from such alteration, modification, copying or reverse engineering.
5. Renesas Electronics products are classified according to the following two quality grades: "Standard" and "High Quality". The intended applications for each Renesas Electronics product depends on the product's quality grade, as indicated below.  
"Standard": Computers; office equipment; communications equipment; test and measurement equipment; audio and visual equipment; home electronic appliances; machine tools; personal electronic equipment; industrial robots; etc.  
"High Quality": Transportation equipment (automobiles, trains, ships, etc.); traffic control (traffic lights); large-scale communication equipment; key financial terminal systems; safety control equipment; etc.  
Unless expressly designated as a high reliability product or a product for harsh environments in a Renesas Electronics data sheet or other Renesas Electronics document, Renesas Electronics products are not intended or authorized for use in products or systems that may pose a direct threat to human life or bodily injury (artificial life support devices or systems; surgical implantations; etc.), or may cause serious property damage (space system; undersea repeaters; nuclear power control systems; aircraft control systems; key plant systems; military equipment; etc.). Renesas Electronics disclaims any and all liability for any damages or losses incurred by you or any third parties arising from the use of any Renesas Electronics product that is inconsistent with any Renesas Electronics data sheet, user's manual or other Renesas Electronics document.
6. When using Renesas Electronics products, refer to the latest product information (data sheets, user's manuals, application notes, "General Notes for Handling and Using Semiconductor Devices" in the reliability handbook, etc.), and ensure that usage conditions are within the ranges specified by Renesas Electronics with respect to maximum ratings, operating power supply voltage range, heat dissipation characteristics, installation, etc. Renesas Electronics disclaims any and all liability for any malfunctions, failure or accident arising out of the use of Renesas Electronics products outside of such specified ranges.
7. Although Renesas Electronics endeavors to improve the quality and reliability of Renesas Electronics products, semiconductor products have specific characteristics, such as the occurrence of failure at a certain rate and malfunctions under certain use conditions. Unless designated as a high reliability product or a product for harsh environments in a Renesas Electronics data sheet or other Renesas Electronics document, Renesas Electronics products are not subject to radiation resistance design. You are responsible for implementing safety measures to guard against the possibility of bodily injury, injury or damage caused by fire, and/or danger to the public in the event of a failure or malfunction of Renesas Electronics products, such as safety design for hardware and software, including but not limited to redundancy, fire control and malfunction prevention, appropriate treatment for aging degradation or any other appropriate measures. Because the evaluation of microcomputer software alone is very difficult and impractical, you are responsible for evaluating the safety of the final products or systems manufactured by you.
8. Please contact a Renesas Electronics sales office for details as to environmental matters such as the environmental compatibility of each Renesas Electronics product. You are responsible for carefully and sufficiently investigating applicable laws and regulations that regulate the inclusion or use of controlled substances, including without limitation, the EU RoHS Directive, and using Renesas Electronics products in compliance with all these applicable laws and regulations. Renesas Electronics disclaims any and all liability for damages or losses occurring as a result of your noncompliance with applicable laws and regulations.
9. Renesas Electronics products and technologies shall not be used for or incorporated into any products or systems whose manufacture, use, or sale is prohibited under any applicable domestic or foreign laws or regulations. You shall comply with any applicable export control laws and regulations promulgated and administered by the governments of any countries asserting jurisdiction over the parties or transactions.
10. It is the responsibility of the buyer or distributor of Renesas Electronics products, or any other party who distributes, disposes of, or otherwise sells or transfers the product to a third party, to notify such third party in advance of the contents and conditions set forth in this document.
11. This document shall not be reprinted, reproduced or duplicated in any form, in whole or in part, without prior written consent of Renesas Electronics.
12. Please contact a Renesas Electronics sales office if you have any questions regarding the information contained in this document or Renesas Electronics products.  
(Note 1) "Renesas Electronics" as used in this document means Renesas Electronics Corporation and also includes its directly or indirectly controlled subsidiaries.  
(Note 2) "Renesas Electronics product(s)" means any product developed or manufactured by or for Renesas Electronics.

(Rev.4.0-1 November 2017)



### SALES OFFICES

Renesas Electronics Corporation

<http://www.renesas.com>

Refer to "<http://www.renesas.com/>" for the latest and detailed information.

**Renesas Electronics America Inc.**  
1001 Murphy Ranch Road, Milpitas, CA 95035, U.S.A.  
Tel: +1-408-432-8888, Fax: +1-408-434-5351

**Renesas Electronics Canada Limited**  
9251 Yonge Street, Suite 8309 Richmond Hill, Ontario Canada L4C 9T3  
Tel: +1-905-237-2004

**Renesas Electronics Europe Limited**  
Dukes Meadow, Millboard Road, Bourne End, Buckinghamshire, SL8 5FH, U.K  
Tel: +44-1628-651-700, Fax: +44-1628-651-804

**Renesas Electronics Europe GmbH**  
Arcadiastrasse 10, 40472 Düsseldorf, Germany  
Tel: +49-211-6503-0, Fax: +49-211-6503-1327

**Renesas Electronics (China) Co., Ltd.**  
Room 1709 Quantum Plaza, No.27 ZhichunLu, Haidian District, Beijing, 100191 P. R. China  
Tel: +86-10-8235-1155, Fax: +86-10-8235-7679

**Renesas Electronics (Shanghai) Co., Ltd.**  
Unit 301, Tower A, Central Towers, 555 Langao Road, Putuo District, Shanghai, 200333 P. R. China  
Tel: +86-21-2226-0888, Fax: +86-21-2226-0999

**Renesas Electronics Hong Kong Limited**  
Unit 1601-1611, 16/F., Tower 2, Grand Century Place, 193 Prince Edward Road West, Mongkok, Kowloon, Hong Kong  
Tel: +852-2265-6688, Fax: +852-2886-9022

**Renesas Electronics Taiwan Co., Ltd.**  
13F, No. 363, Fu Shing North Road, Taipei 10543, Taiwan  
Tel: +886-2-8175-9600, Fax: +886-2-8175-9670

**Renesas Electronics Singapore Pte. Ltd.**  
80 Bendemeer Road, Unit #06-02 Hyflux Innovation Centre, Singapore 339949  
Tel: +65-6213-0200, Fax: +65-6213-0300

**Renesas Electronics Malaysia Sdn.Bhd.**  
Unit 1207, Block B, Menara Amcorp, Amcorp Trade Centre, No. 18, Jln Persiaran Barat, 46050 Petaling Jaya, Selangor Darul Ehsan, Malaysia  
Tel: +60-3-7955-9390, Fax: +60-3-7955-9510

**Renesas Electronics India Pvt. Ltd.**  
No.777C, 100 Feet Road, HAL 2nd Stage, Indiranagar, Bangalore 560 038, India  
Tel: +91-80-67208700, Fax: +91-80-67208777

**Renesas Electronics Korea Co., Ltd.**  
17F, KAMCO Yangjae Tower, 262, Gangnam-daero, Gangnam-gu, Seoul, 06265 Korea  
Tel: +82-2-558-3737, Fax: +82-2-558-5338