



STEVAL-ILL031V1

Digital constant-current controller for LED driving based on the STM8S208x

Data brief

Features

- DC input voltage: 48 V
- Buck stage adapts output voltage to drive LEDs with selected current
- Four DC-DC buck converters allow driving of 4 LED strings, managing up to 120 W
- Employs 3 W LEDs to obtain 30 W-per-string (10 LEDs in series in each string)
- Low voltage-sensing circuitry
- Logic level MOSFETs driven by the microcontroller without gate driver (ground referred)
- High efficiency (up to 98%)
- RoHS compliant



Description

The purpose of the STEVAL-ILL031V1 demonstration board is to present a new digital approach to performing real average current control on an LED streetlighting platform.

This LED streetlight platform is developed on a DC-DC “inverse buck” converter, taking advantage of power switch control and conditioning signal circuitry for current sensing.

Benefits of this design include low energy consumption, low maintenance, and reduced size and weight. The solution is customized for streetlighting applications, but can be extended to many other segments.

1 Schematic diagrams

Figure 1. Control stage schematic (1 of 2)

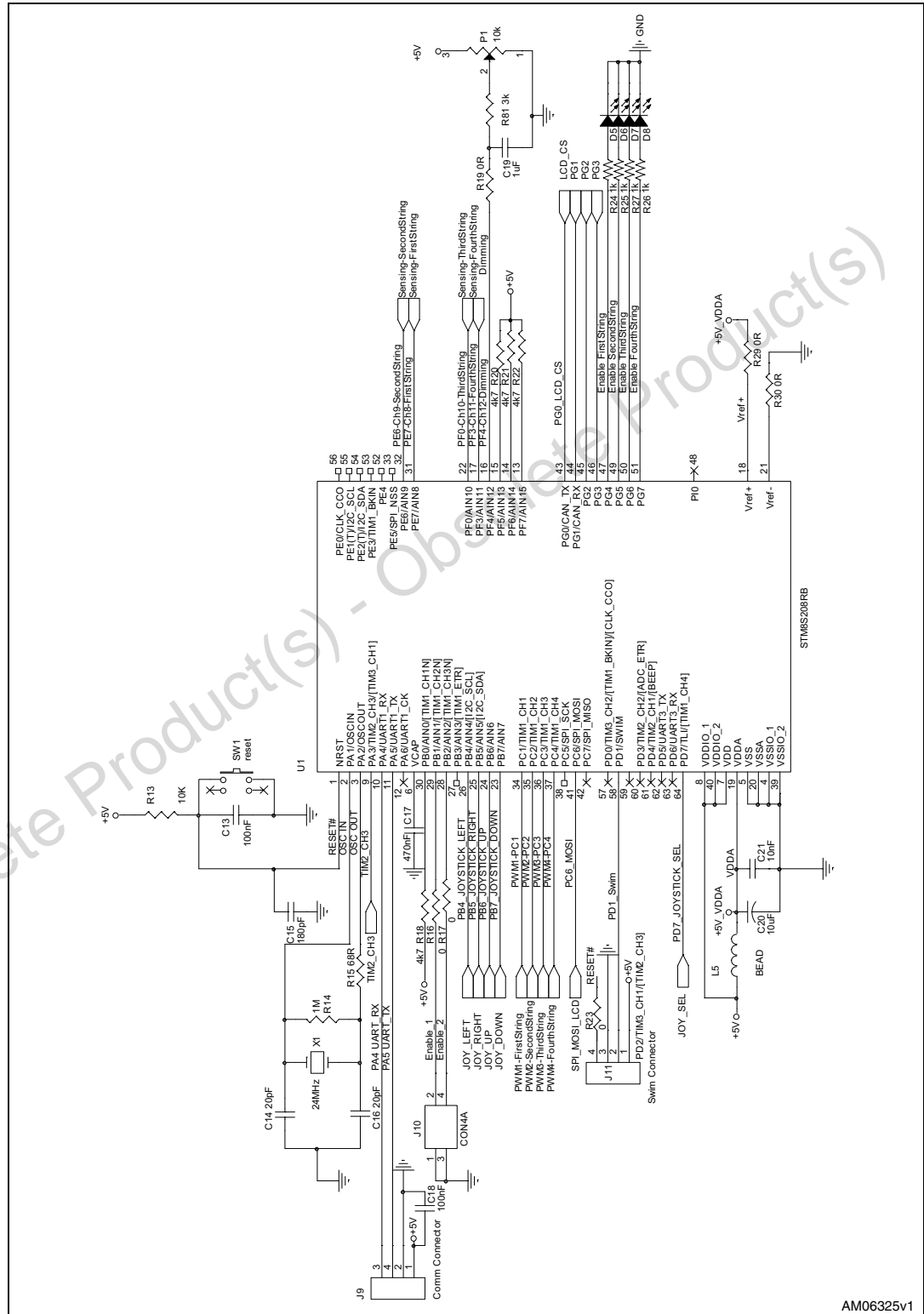

Figure 2. Control stage schematic (2 of 2)

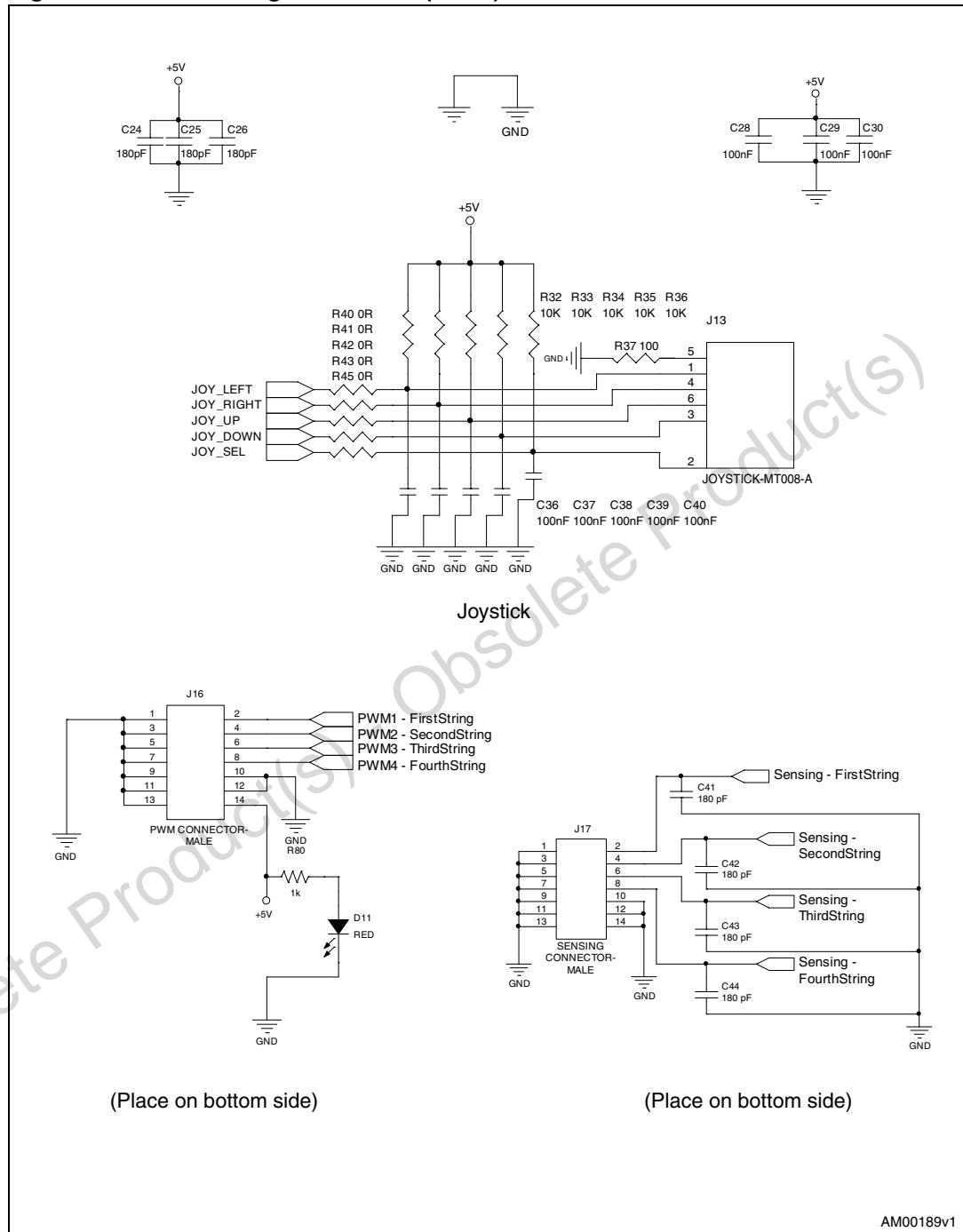
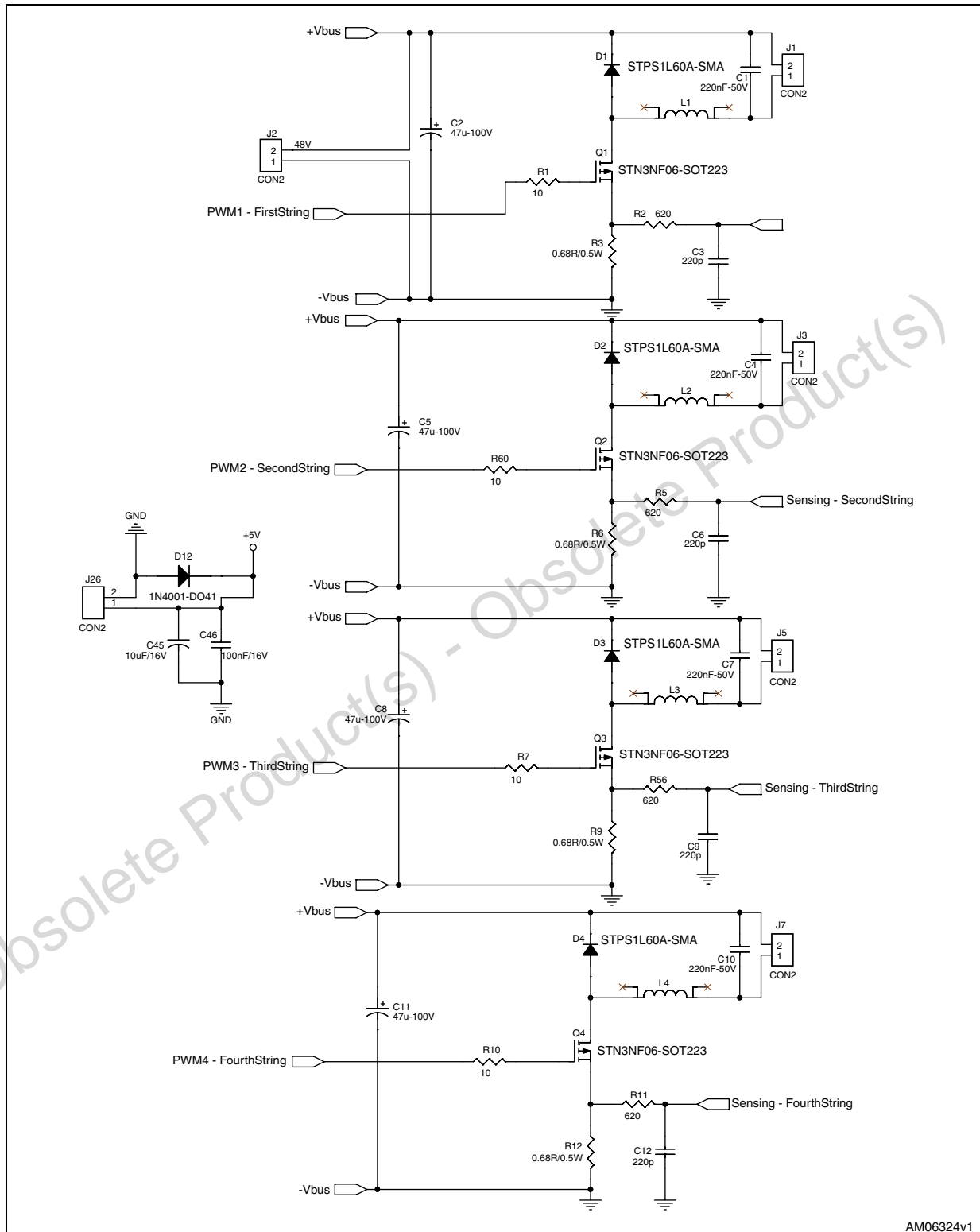

Figure 3. Power stage schematic



AM06324v1

2 Revision history

Table 1. Document revision history

Date	Revision	Changes
23-Apr-2010	1	Initial release.
11-Nov-2010	2	<ul style="list-style-type: none">– Changed board photo on coverpage– Divided control stage schematic diagram into two figures (<i>Figure 1</i> and <i>Figure 2</i>) to improve readability– Added <i>Figure 3: Power stage schematic</i>

Obsolete Product(s) - Obsolete Product(s)

Please Read Carefully:

Information in this document is provided solely in connection with ST products. STMicroelectronics NV and its subsidiaries ("ST") reserve the right to make changes, corrections, modifications or improvements, to this document, and the products and services described herein at any time, without notice.

All ST products are sold pursuant to ST's terms and conditions of sale.

Purchasers are solely responsible for the choice, selection and use of the ST products and services described herein, and ST assumes no liability whatsoever relating to the choice, selection or use of the ST products and services described herein.

No license, express or implied, by estoppel or otherwise, to any intellectual property rights is granted under this document. If any part of this document refers to any third party products or services it shall not be deemed a license grant by ST for the use of such third party products or services, or any intellectual property contained therein or considered as a warranty covering the use in any manner whatsoever of such third party products or services or any intellectual property contained therein.

UNLESS OTHERWISE SET FORTH IN ST'S TERMS AND CONDITIONS OF SALE ST DISCLAIMS ANY EXPRESS OR IMPLIED WARRANTY WITH RESPECT TO THE USE AND/OR SALE OF ST PRODUCTS INCLUDING WITHOUT LIMITATION IMPLIED WARRANTIES OF MERCHANTABILITY, FITNESS FOR A PARTICULAR PURPOSE (AND THEIR EQUIVALENTS UNDER THE LAWS OF ANY JURISDICTION), OR INFRINGEMENT OF ANY PATENT, COPYRIGHT OR OTHER INTELLECTUAL PROPERTY RIGHT.

UNLESS EXPRESSLY APPROVED IN WRITING BY AN AUTHORIZED ST REPRESENTATIVE, ST PRODUCTS ARE NOT RECOMMENDED, AUTHORIZED OR WARRANTED FOR USE IN MILITARY, AIR CRAFT, SPACE, LIFE SAVING, OR LIFE SUSTAINING APPLICATIONS, NOR IN PRODUCTS OR SYSTEMS WHERE FAILURE OR MALFUNCTION MAY RESULT IN PERSONAL INJURY, DEATH, OR SEVERE PROPERTY OR ENVIRONMENTAL DAMAGE. ST PRODUCTS WHICH ARE NOT SPECIFIED AS "AUTOMOTIVE GRADE" MAY ONLY BE USED IN AUTOMOTIVE APPLICATIONS AT USER'S OWN RISK.

Resale of ST products with provisions different from the statements and/or technical features set forth in this document shall immediately void any warranty granted by ST for the ST product or service described herein and shall not create or extend in any manner whatsoever, any liability of ST.

ST and the ST logo are trademarks or registered trademarks of ST in various countries.

Information in this document supersedes and replaces all information previously supplied.

The ST logo is a registered trademark of STMicroelectronics. All other names are the property of their respective owners.

© 2010 STMicroelectronics - All rights reserved

STMicroelectronics group of companies

Australia - Belgium - Brazil - Canada - China - Czech Republic - Finland - France - Germany - Hong Kong - India - Israel - Italy - Japan - Malaysia - Malta - Morocco - Philippines - Singapore - Spain - Sweden - Switzerland - United Kingdom - United States of America

www.st.com