



EVALPM8803-FLY

**EVALPM8803-FLY: IEEE802.3at compliant demonstration kit
with synchronous flyback PoE converter**

Features

- IEEE 802.3at compliant
- Support for Gigabit Ethernet
- Data pass-through for the Ethernet data
- Works with power supplied from Ethernet LAN cables or from local auxiliary sources
- Successful IEEE802.3at layer1 classification indicator
- Single output 3.3 V/5 V
- 90+% converter efficiency
- Board size 10x13 cm

Description

The EVALPM8803-FLY is a demonstration board implementing an IEEE802.3at compatible interface together with a synchronous rectification flyback converter based on PM8803.

The board is designed to work up to 30 W, and with minimal changes the output voltage can be selected either 5 V or 3.3 V. For sake of flexibility, alternative footprint have been foreseen for the main component (MOS, transformer, etc).

It is possible to connect auxiliary sources to one of the 2 jacks in the EVALPM8803-FLY like in real application design. In one case thanks to the PM8803 feature, prevalence of the auxiliary source can be guaranteed.

Three LEDs give indication of :

- the converter is running
- an external auxiliary source is connected to the board a type 2 PSE is connected to the board.

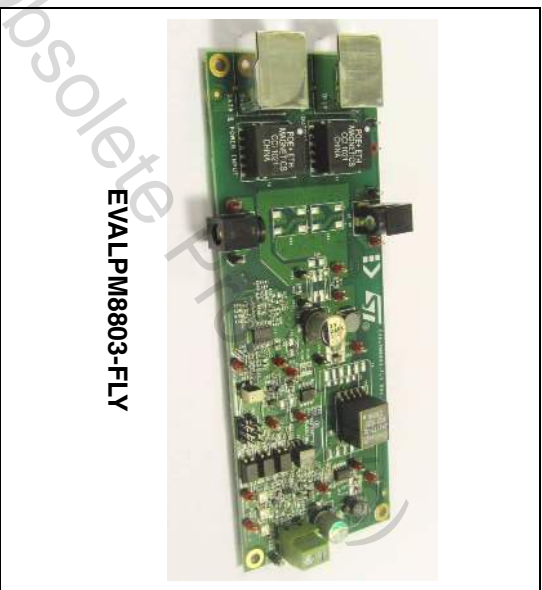

1 Schematic diagrams

Figure 1. Demonstration kit schematic: detail of the PoE+ input section including data transformer, diode bridges, protection and optional CM choke

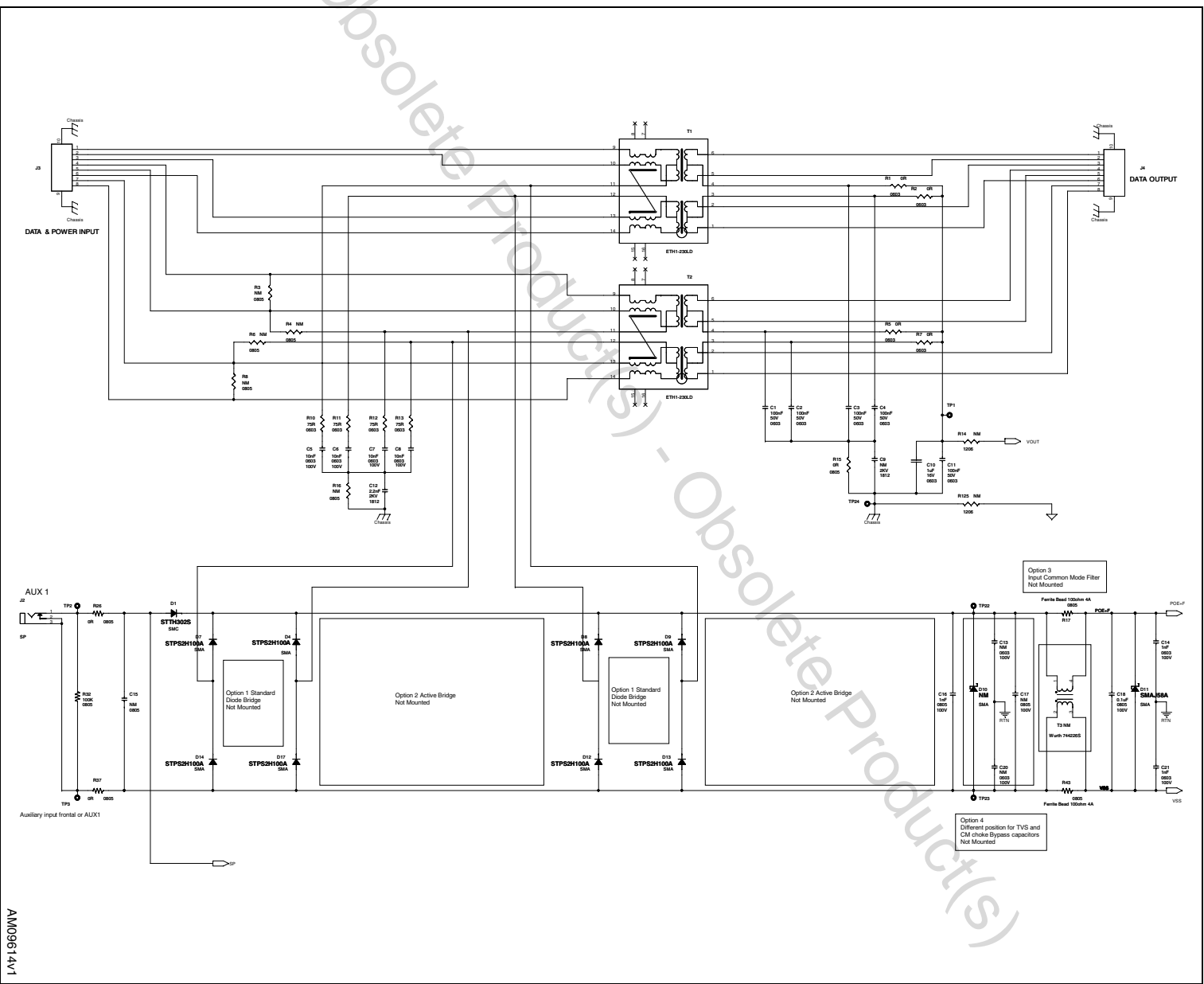

AM009614V1

Figure 2. Demonstration kit schematic: detail of the PoE+ section based on flyback topology with synchronous rectification

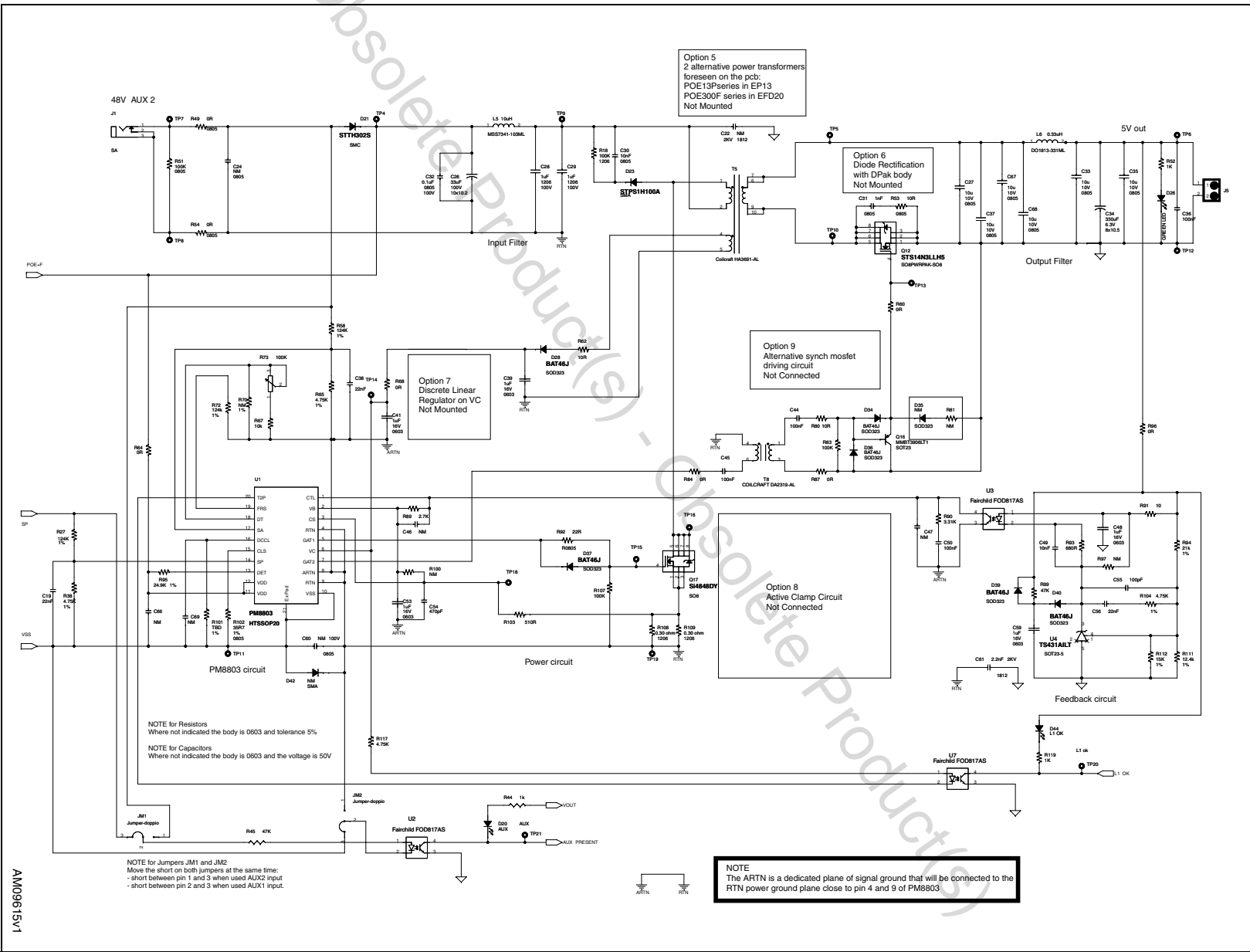

2 Revision history

Table 1. Document revision history

Date	Revision	Changes
11-Apr-2011	1	Initial release.

Obsolete Product(s) - Obsolete Product(s)

Please Read Carefully:

Information in this document is provided solely in connection with ST products. STMicroelectronics NV and its subsidiaries ("ST") reserve the right to make changes, corrections, modifications or improvements, to this document, and the products and services described herein at any time, without notice.

All ST products are sold pursuant to ST's terms and conditions of sale.

Purchasers are solely responsible for the choice, selection and use of the ST products and services described herein, and ST assumes no liability whatsoever relating to the choice, selection or use of the ST products and services described herein.

No license, express or implied, by estoppel or otherwise, to any intellectual property rights is granted under this document. If any part of this document refers to any third party products or services it shall not be deemed a license grant by ST for the use of such third party products or services, or any intellectual property contained therein or considered as a warranty covering the use in any manner whatsoever of such third party products or services or any intellectual property contained therein.

UNLESS OTHERWISE SET FORTH IN ST'S TERMS AND CONDITIONS OF SALE ST DISCLAIMS ANY EXPRESS OR IMPLIED WARRANTY WITH RESPECT TO THE USE AND/OR SALE OF ST PRODUCTS INCLUDING WITHOUT LIMITATION IMPLIED WARRANTIES OF MERCHANTABILITY, FITNESS FOR A PARTICULAR PURPOSE (AND THEIR EQUIVALENTS UNDER THE LAWS OF ANY JURISDICTION), OR INFRINGEMENT OF ANY PATENT, COPYRIGHT OR OTHER INTELLECTUAL PROPERTY RIGHT.

UNLESS EXPRESSLY APPROVED IN WRITING BY AN AUTHORIZED ST REPRESENTATIVE, ST PRODUCTS ARE NOT RECOMMENDED, AUTHORIZED OR WARRANTED FOR USE IN MILITARY, AIR CRAFT, SPACE, LIFE SAVING, OR LIFE SUSTAINING APPLICATIONS, NOR IN PRODUCTS OR SYSTEMS WHERE FAILURE OR MALFUNCTION MAY RESULT IN PERSONAL INJURY, DEATH, OR SEVERE PROPERTY OR ENVIRONMENTAL DAMAGE. ST PRODUCTS WHICH ARE NOT SPECIFIED AS "AUTOMOTIVE GRADE" MAY ONLY BE USED IN AUTOMOTIVE APPLICATIONS AT USER'S OWN RISK.

Resale of ST products with provisions different from the statements and/or technical features set forth in this document shall immediately void any warranty granted by ST for the ST product or service described herein and shall not create or extend in any manner whatsoever, any liability of ST.

ST and the ST logo are trademarks or registered trademarks of ST in various countries.

Information in this document supersedes and replaces all information previously supplied.

The ST logo is a registered trademark of STMicroelectronics. All other names are the property of their respective owners.

© 2011 STMicroelectronics - All rights reserved

STMicroelectronics group of companies

Australia - Belgium - Brazil - Canada - China - Czech Republic - Finland - France - Germany - Hong Kong - India - Israel - Italy - Japan - Malaysia - Malta - Morocco - Philippines - Singapore - Spain - Sweden - Switzerland - United Kingdom - United States of America

www.st.com

