

LOC AD	DIST 25	REVISIONS				
P	LTR	DESCRIPTION	DATE	DWN	APVD	
	0	DRAWN	-	-	-	

1. WIRE BARREL WILL ACCEPT 16-18 AWG WIRE.
2. MATES WITH PART NUMBER 148410-1.
3. RECOMMENDED CRIMPING TOOL: DANIELS TOOL #FT8, POSITIONER P/N TP731, SETTING #7 (16 AWG), #6 (18 AWG), STRIP LG 8.13[.320].

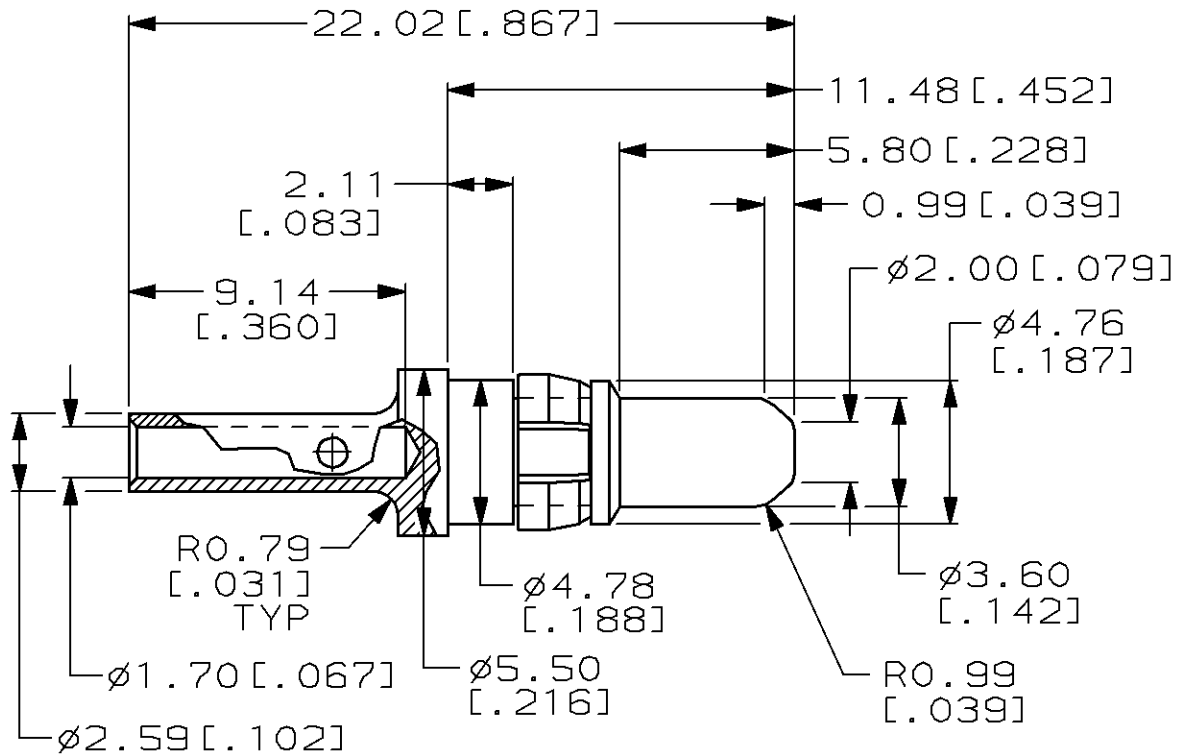

RELEASED FOR PUBLICATION

ALL RIGHTS RESERVED. BY AMP INCORPORATED. COPYRIGHT 19

0.00076 [.000030] GOLD	CONTACT; BRASS	148407-1
	RETAINING RING; BERYLLIUM COPPER	
CONT AREA FINISH	MATERIAL	PART NUMBER

DIMENSIONS: mm	DWN L. BRINER 10/10/97	MATERIAL -	FINISH -
TOLERANCES UNLESS OTHERWISE SPECIFIED:	CHK R. PATTERSON 10/10/97	AMP Incorporated Harrisburg, PA 17105-3608	
0 PLC ±-	APVD R. PATTERSON 10/10/97		
1 PLC ±-	PRODUCT SPEC	NAME PIN CONTACT, POWER, EUROCARD TYPE M, 10 AMP	
2 PLC ±0.13 [.005]	APPLICATION SPEC	SIZE A4	CAGE CODE 00779
3 PLC ±-		DRAWING NO C-148407	
4 PLC ±-		SCALE 4:1	SHEET 1 OF 1
ANGLES ±-	WEIGHT -	REV 0	
CUSTOMER DRAWING			