

**MARKETING SALES DRAWING**  
**DIMENSIONS IN INCHES - DO NOT SCALE THIS DRAWING**  
**DIMENSIONS IN METRIC - [ ]**

Electrical Testing  
per Tusonix standard  
test plans and Mil-Std-202  
Test Methods.

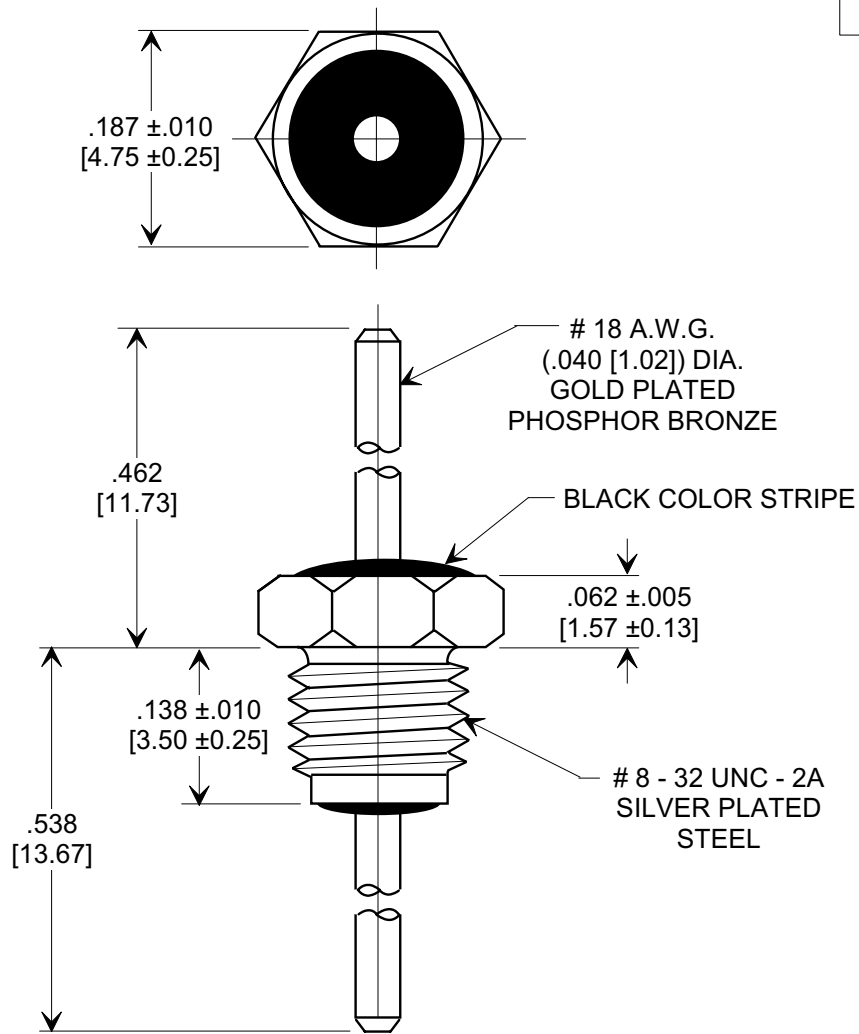
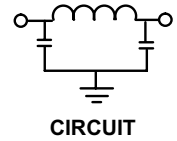
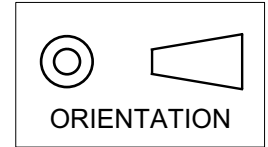

**NOTES:**

- TUSONIX STANDARD PART NUMBER: 4205-011.  
TUSONIX RoHS COMPLIANT PART NUMBER: 4205-011 LF.  
CUSTOMER MUST SPECIFY STANDARD OR RoHS PART NUMBER WHEN ORDERING.
- PART MARKING: TRADEMARK AND VARIATION NUMBER ON HEX FLATS.  
STANDARD PART: BLACK INK. RoHS PART: GREEN INK.
- MAX. MOUNTING TORQUE 5 lb.-in. [.265 N-m].

MIN. CAP. (pF)	WORKING VOLTAGE (WVdc)		CURRENT Idc	I.R. MIN. @ 100 (VDC)	DWV (VDC)	MINIMUM NO LOAD INSERTION LOSS (dB) AT 25°C PER MIL-STD-220			
	85° C	125° C				10 MHz	100 MHz	1 GHz	10 GHz
1500	250	125	15	10 G Ω	500	5	35	60	60

X-2015 Rev-0	<b>REVISION RECORD</b>				--TOLERANCES-- Unless Otherwise Specified	Title			
	Original Release C.O. <b>5836</b>	0	BLACK COLOR STRIPE ADDED 1500 WAS 2000. L.E. 4-12-91	1		<b>BUSHING STYLE EMI FILTER</b>			
	REISSUED <b>5836</b>	1	RDN TO COMP FMT & ADDED METRIC. S.M. 05-28-02	2	Drawn			S.M. 05-28-02	Scale
	20020523-4-02	2	NOTES 1 & 2 ADDED. S.M. 06-09-05	3	20050607-1-03	ADDED IR & DWV. S.M. 12-01-05	20051102-4-06	4	Approved
				<b>TUSONIX</b> TUCSON, ARIZONA	<b>A</b>	<b>4205-011</b>			