

MODEL ENC8 - NEMA 4 ENCLOSURES FOR CUB4, CUB5, DT8 & DT9 UNITS

ENC8A & ENC8B - PLASTIC ENCLOSURES

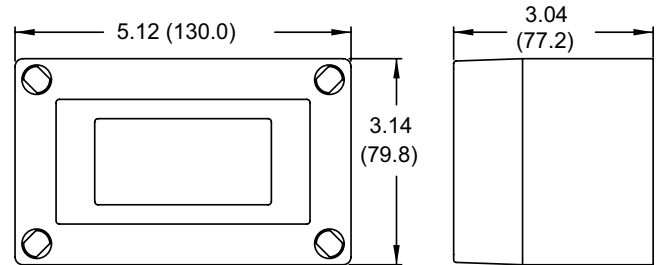

ENC8A DIMENSIONS In inches (mm)



DESCRIPTION

These enclosures are designed for applications requiring a water resistant instrument enclosure. The enclosures are fabricated of polycarbonate and are designed to withstand NEMA 4X/IP65 wash-down applications. The enclosures must be drilled to accept conduit fittings or other types of wiring connectors. The enclosures can be used free-standing, or securely fastened to a mounting surface.

ORDERING INFORMATION

MODEL NO.	DESCRIPTION	PART NUMBER
ENC8A	Plastic Enclosure for single units	ENC8A000
ENC8B	Plastic Enclosure for units with an MLPS1 attached	ENC8B000

For More information on Pricing, Enclosures & Panel Mount Kits, refer to the RLC Catalog or contact your local RLC Distributor.

ENC8B DIMENSIONS In inches (mm)

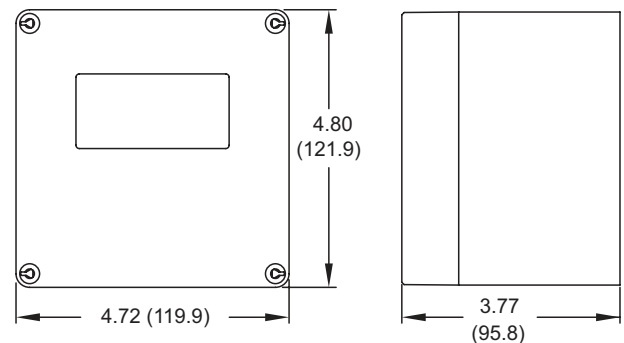

ENC8A INSTALLATION

It is recommended to wire the unit before mounting it in the enclosure to ensure good electrical connections. The following steps outline the most common sequence for installing a unit without an MLPS1 attached.

- Determine the location of the conduit fitting and drill the necessary hole. Install the fitting and bring the wiring into the enclosure.
- Slide the panel gasket over the rear of the unit to the back of the bezel.
- Assemble nut fastener and mounting screw onto both sides of the mounting clip. The tip of the screw should not project from the hole in mounting clip.
- Install the unit through the opening in the front of the lid until the bezel flange contacts the panel.
- Slide the mounting plate over the rear of the unit until it is against the inside front of the enclosure.
- Slide the mounting clip over the rear of the unit until the mounting clip is against the inside of the enclosure. The mounting clip has latching features which engage into mating features on the unit's housing.
Note: It is necessary to hold the unit in place when sliding the mounting clip into position.
- Alternately tighten each screw to ensure uniform gasket pressure. Visually inspect the front panel gasket. The gasket should be compressed to about 75 to 80% of its original thickness (Recommended torque is 28 to 36 in-oz.). If not, gradually turn mounting screws to further compress the gasket.
- If the gasket is not adequately compressed, and the mounting screws can no longer be turned, loosen the mounting screws and check that the mounting clip is latched as close as possible to the inside of enclosure. Repeat the procedure for tightening the screws.

- Connect the necessary wires to the unit for the application desired.
- Assemble the enclosure with the screws provided. Alternately tighten each screw to ensure uniform gasket pressure.

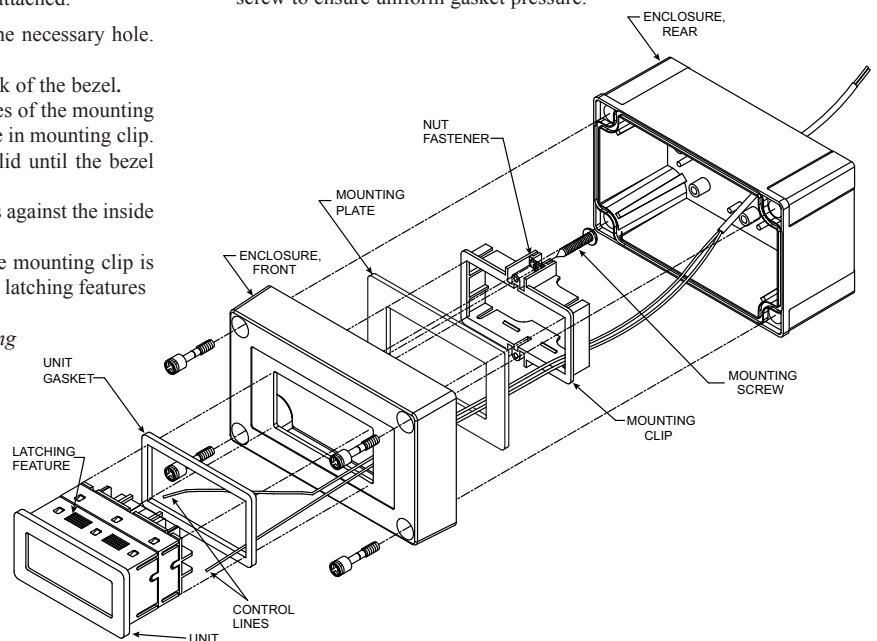

ENC8B w/ MLPS1 Installation

Installing a unit with an MLPS1 attached requires some planning. It is recommended that the unit with the MLPS1 attached be temporarily installed in the enclosure to determine the best location for the conduit fitting to avoid interference with the MLPS1.

1. Determine the location of the conduit fitting and drill the necessary hole. Install the fitting and bring the wiring into the enclosure.
2. Slide the panel gasket over the rear of the unit to the back of the bezel.
3. Remove the common and V+ screw terminals from the rear of the unit (save for later use) and replace them with the stand-offs (supplied with the MLPS1).
4. Assemble nut fastener and mounting screw onto both sides of the mounting clip.
5. Install the unit through the opening in the front of the lid until the bezel flange contacts the panel mounted gasket.
6. Slide the mounting plate over the rear of the unit until it is against the inside front of the enclosure.
7. Slide the mounting clip over the rear of the unit until the mounting clip is against the inside of the enclosure. The mounting clip has latching features which engage into mating features on the unit's housing.

Note: It is necessary to hold the unit in place when sliding the mounting clip into position.

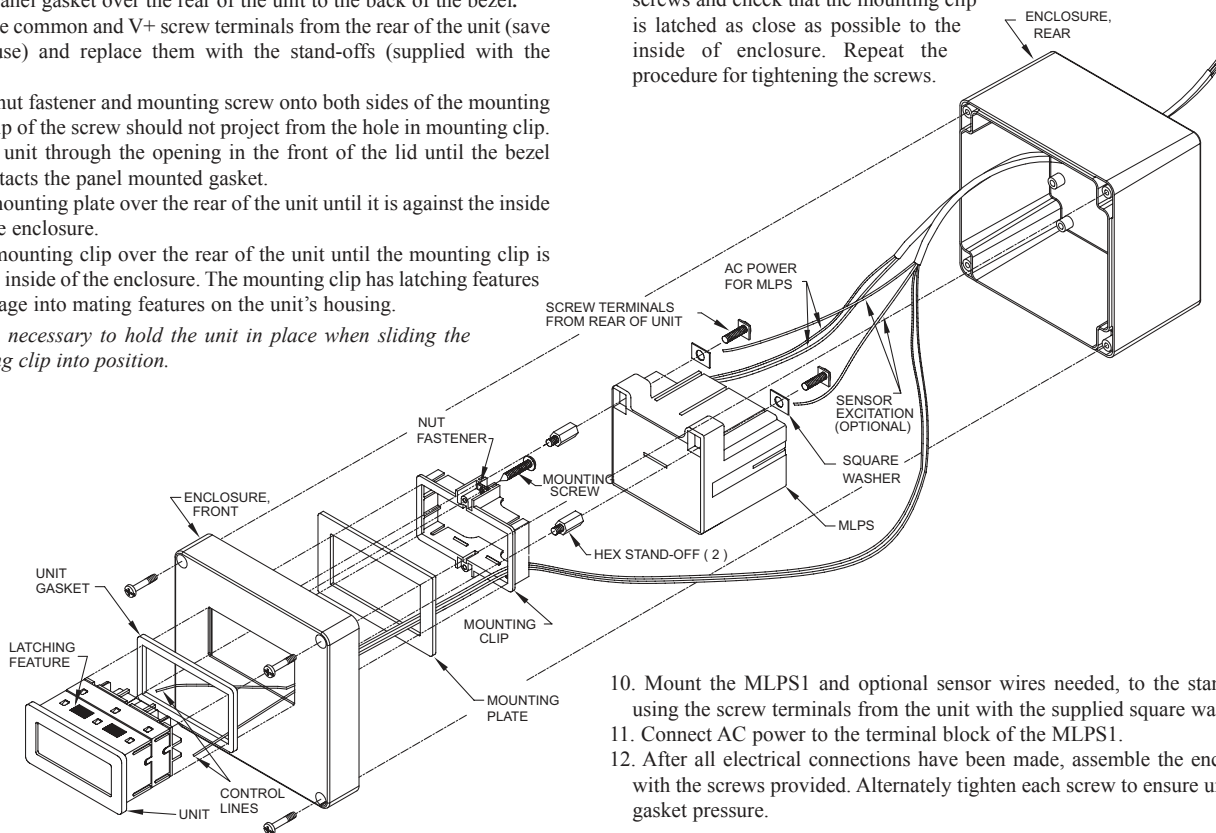

8. Alternately tighten each screw to ensure uniform gasket pressure. Visually inspect the front panel gasket. The gasket should be compressed to about 75 to 80% of its original thickness (Recommended torque is 28 to 36 in.-oz.). If not, gradually turn mounting screws to further compress the gasket.
9. If the gasket is not adequately compressed, and the mounting screws can no longer be turned, loosen the mounting screws and check that the mounting clip is latched as close as possible to the inside of enclosure. Repeat the procedure for tightening the screws.

10. Mount the MLPS1 and optional sensor wires needed, to the stand-offs using the screw terminals from the unit with the supplied square washers.
11. Connect AC power to the terminal block of the MLPS1.
12. After all electrical connections have been made, assemble the enclosure with the screws provided. Alternately tighten each screw to ensure uniform gasket pressure.

ENC8 - STEEL ENCLOSURE



DESCRIPTION

This enclosure is designed for use with the CUB4, CUB5, DT8 & DT9 units. The enclosures are large enough to accommodate a Micro-line Power Supply (MLPS1) attached to the unit. These rugged enclosures are fabricated of formed steel with all seams welded to withstand NEMA 4/IP65 wash-down applications. The kits are coated with a durable black polyurethane finish.

The holes for conduit fittings or other types of wiring connectors can be drilled through the removable rear access panel, or through the enclosure itself.

The enclosures can be free standing or securely fastened to a mounting surface with the brackets and hardware found in the mounting kit (provided with the enclosure). The brackets also allow the enclosure to be raised and/or tilted from the mounting surface in order to achieve the most favorable operating position. Provided are four self-stick foot pads that can be applied to the bottom of the enclosure to protect the mounting surface. The foot pads are particularly useful for free standing installations.

DIMENSIONS In inches (mm)

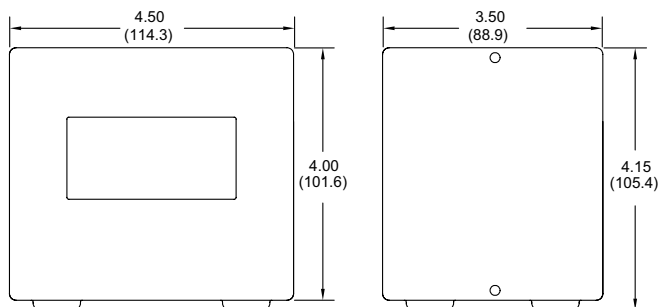

ORDERING INFORMATION

MODEL NO	DESCRIPTION	PART NUMBER
ENC8	NEMA 4/IP65 ENCLOSURE	ENC80000

For More information on Pricing, Enclosures & Panel Mount Kits, refer to the RLC Catalog or contact your local RLC Distributor.

ENC8 INSTALLATION

It is recommended to wire the unit before mounting it in the enclosure to ensure good electrical connections. The following steps outline the most common sequence for installing a unit without an MLPS1 attached.

1. Determine the location of the conduit fitting and drill the necessary hole.
2. Apply adhesive side of panel gasket to rear enclosure opening.
DO NOT APPLY THE ADHESIVE SIDE OF THE GASKET TO THE ACCESS PANEL.
3. Slide the panel gasket over the rear of the unit to the back of the bezel.
4. Assemble nut fastener and mounting screw onto both sides of the mounting clip. The tip of the screw should not project from the hole in mounting clip.
5. Route the wire to be connected to the unit from the conduit fitting through the mounting clip, and then through the rear of the enclosure and out the front.
6. Connect the necessary wires to the unit for the application desired.
7. Install the unit through the opening in the front of the enclosure until the bezel flange contacts the panel.
8. Slide the mounting clip over the rear of the unit until the mounting clip is against the inside of the enclosure. The mounting clip has latching features which engage into mating features on the unit's housing.
Note: It is necessary to hold the unit in place when sliding the mounting clip into position.
9. Alternately tighten each screw to ensure uniform gasket pressure. Visually inspect the front panel gasket. The gasket should be compressed to about 75 to 80% of its original thickness (Recommended torque is 28 to 36 in-oz.). If not, gradually turn mounting screws to further compress the gasket.

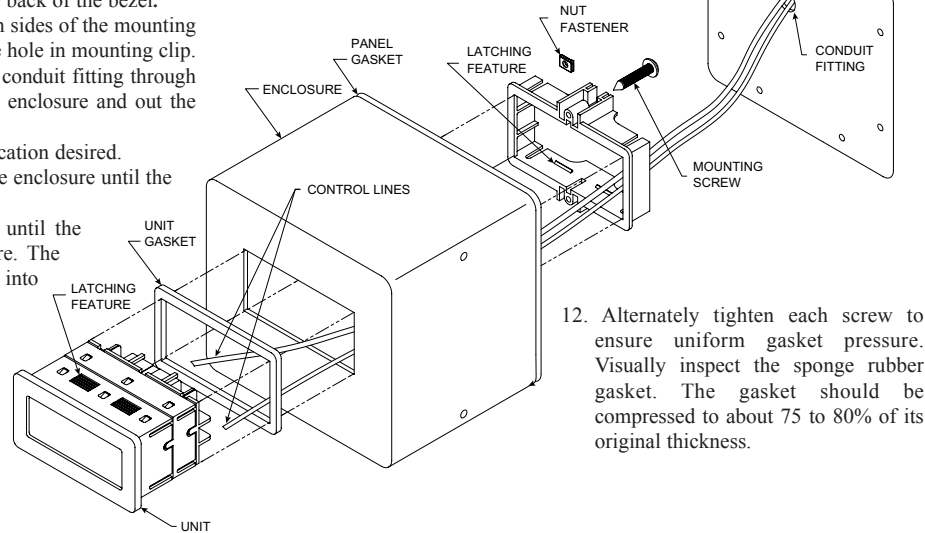

10. If the gasket is not adequately compressed, and the mounting screws can no longer be turned, loosen the mounting screws and check that the mounting clip is latched as close as possible to the inside of the enclosure. Repeat the procedure for tightening the screws.
11. Attach the rear access panel to the enclosure with the eight screws provided.
12. Alternately tighten each screw to ensure uniform gasket pressure. Visually inspect the sponge rubber gasket. The gasket should be compressed to about 75 to 80% of its original thickness.

ENC8 w/ MLPS1 Installation

Installing a unit with an MLPS1 attached requires some planning. It is recommended that the unit with the MLPS1 attached be temporarily installed in the enclosure to determine the best location for the conduit fitting to avoid interference with the MLPS1.

1. Mark the location of the conduit fitting and drill the necessary hole.
2. Apply adhesive side of panel gasket to rear enclosure opening.
DO NOT APPLY THE ADHESIVE SIDE OF THE GASKET TO THE ACCESS PANEL.
3. Slide the panel gasket over the rear of the unit to the back of the bezel.
4. Remove the common and V+ screw terminals from the rear of the unit (save for later use) and replace them with the hex drive stand-offs (supplied with the MLPS1).
5. Assemble nut fastener and mounting screw onto both sides of the mounting clip. The tip of the screw should not project from the hole in mounting clip.
6. Route the wire to be connected to the unit from the conduit fitting through the mounting clip, and then through the rear of the enclosure and out the front.
7. Connect the necessary wires to the unit for the application desired.
8. Install the unit through the opening in the front of the enclosure until the bezel flange contacts the panel mounted gasket.
9. Slide the mounting clip over the rear of the unit until the mounting clip is against the inside of the enclosure. The mounting clip has latching features which engage into mating features on the unit's housing.

Note: It is necessary to hold the unit in place when sliding the mounting clip into position.

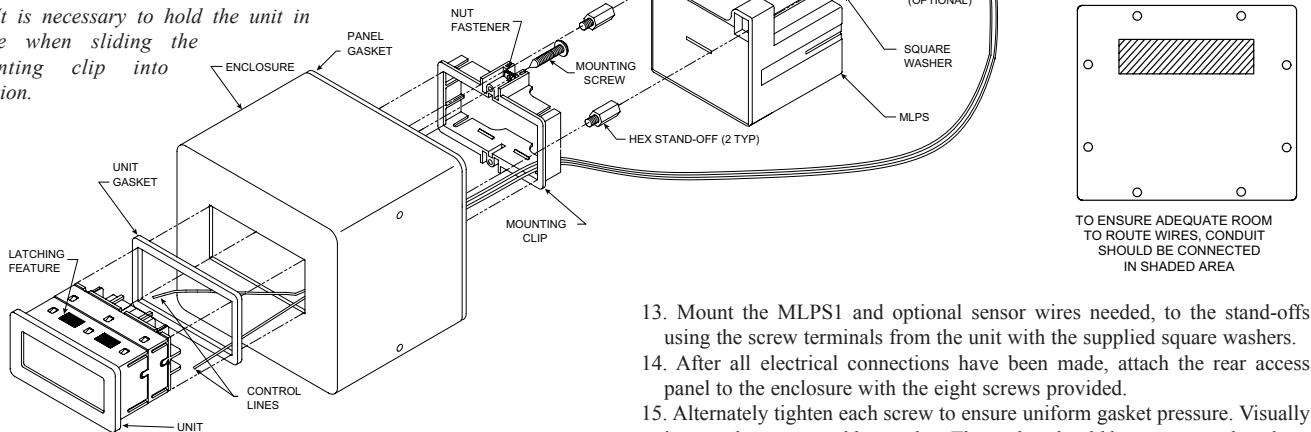

TO ENSURE ADEQUATE ROOM TO ROUTE WIRES, CONDUIT SHOULD BE CONNECTED IN SHADED AREA

10. Alternately tighten each screw to ensure uniform gasket pressure. Visually inspect the front panel gasket. The gasket should be compressed to about 75 to 80% of its original thickness (Recommended torque is 28 to 36 in-oz.). If not, gradually turn mounting screws to further compress the gasket.
11. If the gasket is not adequately compressed, and the mounting screws can no longer be turned, loosen the mounting screws and check that the mounting clip is latched as close as possible to the inside of enclosure. Repeat the procedure for tightening the screws.
12. Connect AC power to the terminal block of the MLPS1.

13. Mount the MLPS1 and optional sensor wires needed, to the stand-offs using the screw terminals from the unit with the supplied square washers.
14. After all electrical connections have been made, attach the rear access panel to the enclosure with the eight screws provided.
15. Alternately tighten each screw to ensure uniform gasket pressure. Visually inspect the sponge rubber gasket. The gasket should be compressed to about 75 to 80% of its original thickness.

MOUNTING THE ENCLOSURE

1. Self-stick foot pads may be applied to the features on the bottom of the enclosure to protect the mounting surface.
2. To securely mount the enclosure, attach the adjustable mounting brackets to the enclosure using the plastic washers and screws. Mounting brackets may be attached to the top or bottom of the enclosure.
3. Secure the adjustable mounting brackets to mounting location with the screws provided.

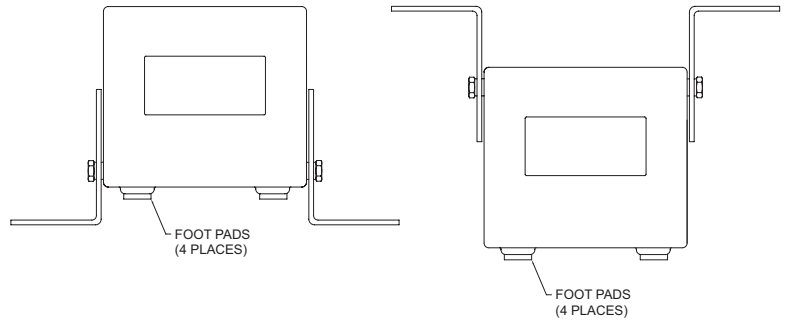
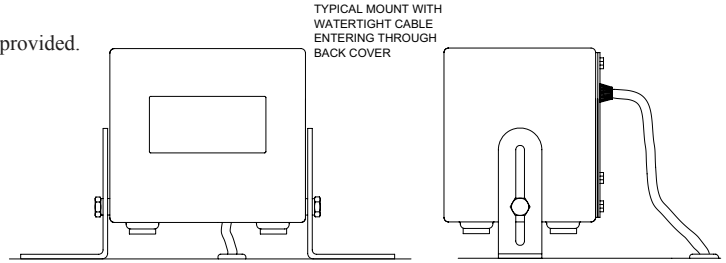
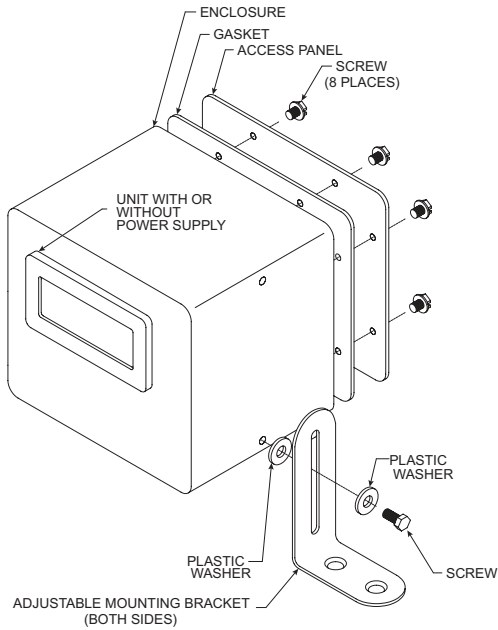

LIMITED WARRANTY

The Company warrants the products it manufactures against defects in materials and workmanship for a period limited to two years from the date of shipment, provided the products have been stored, handled, installed, and used under proper conditions. The Company's liability under this limited warranty shall extend only to the repair or replacement of a defective product, at The Company's option. The Company disclaims all liability for any affirmation, promise or representation with respect to the products.

The customer agrees to hold Red Lion Controls harmless from, defend, and indemnify RLC against damages, claims, and expenses arising out of subsequent sales of RLC products or products containing components manufactured by RLC and based upon personal injuries, deaths, property damage, lost profits, and other matters which Buyer, its employees, or sub-contractors are or may be to any extent liable, including without limitation penalties imposed by the Consumer Product Safety Act (P.L. 92-573) and liability imposed upon any person pursuant to the Magnuson-Moss Warranty Act (P.L. 93-637), as now in effect or as amended hereafter.

No warranties expressed or implied are created with respect to The Company's products except those expressly contained herein. The Customer acknowledges the disclaimers and limitations contained herein and relies on no other warranties or affirmations.

Red Lion Controls
Headquarters
20 Willow Springs Circle
York PA 17406
Tel +1 (717) 767-6511
Fax +1 (717) 764-0839

Red Lion Controls
Europe
Softwareweg 9
NL - 3821 BN Amersfoort
Tel +31 (0) 334 723 225
Fax +31 (0) 334 893 793

Red Lion Controls
India
201-B, 2nd Floor, Park Centra
Opp 32 Mile Stone, Sector-30
Gurgaon-122002 Haryana, India
Tel +91 984 487 0503

Red Lion Controls
China
Unit 302, XinAn Plaza
Building 13, No.99 Tianzhou Road
ShangHai, P.R. China 200223
Tel +86 21 6113 3688
Fax +86 21 6113 3683