

3.3V, Hot Insertion, 8-Bit, 2-Port NanoSwitch™

Features

- Near-Zero propagation delay
- 5-ohm switches connect inputs to outputs
- Fast Switching Speed: 4.5ns (max.)
- Ultra-Low Quiescent Power (0.2µA Typical)
 - Ideally suited for notebook applications
- TTL-compatible control of inputs levels
- ESD protection (2kV Human Body Model and 200V Machine Model)
- Totally Lead-Free & Fully RoHS Compliant (Notes 1 & 2)
- Halogen and Antimony Free. “Green” Device (Note 3)
- For automotive applications requiring specific change control (i.e. parts qualified to AEC-Q100/101/200, PPAP capable, and manufactured in IATF 16949 certified facilities), please [contact us](https://www.diodes.com/quality/product-definitions/) or your local Diodes representative.

<https://www.diodes.com/quality/product-definitions/>
- Packaging (Pb-free & Green):
 - 20-pin SOIC (S)
 - 20-pin QSOP (Q)
 - 20-pin TSSOP (L)

Description

The PI3B3245 is a 3.3V 8-bit, 2-port bus switch designed with a low On-Resistance (5-ohm) allowing inputs to be connected directly to outputs. The bus switch creates no additional propagational delay or additional ground bounce noise. The switches are turned ON by the Bus Enable (\overline{BE}) input signal.

Block Diagram

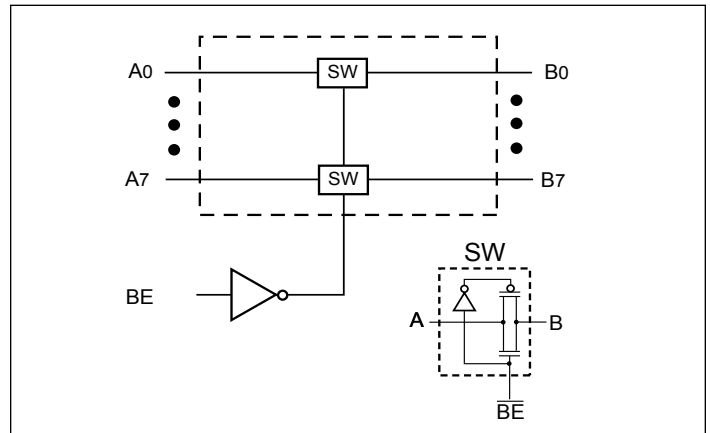

Truth Table

| Function | \overline{BE} | A0-7 |
|------------|-----------------|------|
| Disconnect | H | Hi-Z |
| Connect | L | B0-7 |

Note:

H = High Voltage Level, L = Low Voltage Level, Hi-Z = High Impedance

Notes:

1. No purposely added lead. Fully EU Directive 2002/95/EC (RoHS), 2011/65/EU (RoHS 2) & 2015/863/EU (RoHS 3) compliant.
2. See <https://www.diodes.com/quality/lead-free/> for more information about Diodes Incorporated’s definitions of Halogen- and Antimony-free, “Green” and Lead-free.
3. Halogen- and Antimony-free “Green” products are defined as those which contain <900ppm bromine, <900ppm chlorine (<1500ppm total Br + Cl) and <1000ppm antimony compounds.

Pin Configuration (SOIC, QSOP, TSSOP)

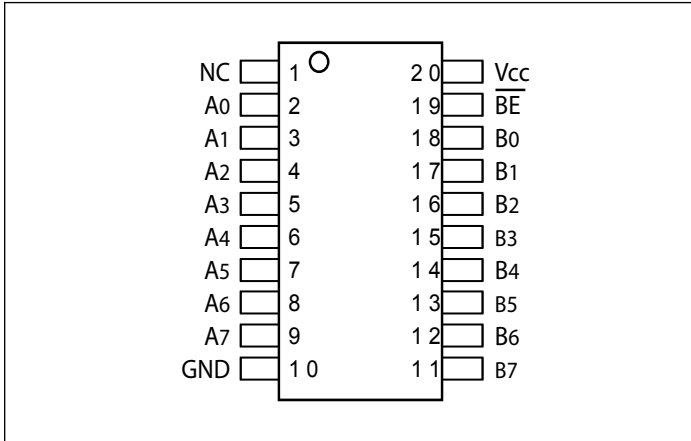

Pin Description

| Pin# | Pin Name | Description |
|--------------------------------|-----------------|-------------------------------|
| 19 | \overline{BE} | Bus Enable Input (Active LOW) |
| 2, 3, 4, 5, 6, 7, 8, 9 | A0-7 | Bus A |
| 18, 17, 16, 15, 14, 13, 12, 11 | B0-7 | Bus B |
| 10 | GND | Ground ⁽¹⁾ |
| 20 | Vcc | Power |
| 1 | NC | Not Connected |

Note 1: UQFN20 package die supply ground is connected to both GND pin and exposed center pad. GND pin must be connected to supply ground for proper device operation. For enhanced thermal, electrical, and board level performance, the exposed pad needs to be soldered to the board using a corresponding thermal pad on the board and for proper heat conduction through the board, thermal vias need to be incorporated in the PCB in the thermal pad region.

Absolute Maximum Ratings

| Parameter | Min. | Max. | Units |
|--|------|------|-------|
| Storage Temperature | -65 | 150 | °C |
| Ambient Temperature with Power Applied | -40 | 85 | °C |
| Supply Voltage to Ground Potential | -0.5 | 4.6 | V |
| DC Input Voltage | -0.5 | 4.6 | V |
| DC Output Current | - | 120 | mA |
| Power Dissipation | - | 0.5 | W |

Stress beyond those listed under “Absolute Maximum Ratings” may cause permanent damage to the device.

DC Electrical Characteristics (Over the Operating Range, $T_A = -40^{\circ}\text{C}$ to $+85^{\circ}\text{C}$, $V_{CC} = 3.3\text{V} \pm 10\%$)

| Parameters | Description | Test Conditions ⁽¹⁾ | Min. | Typ. ⁽²⁾ | Max. | Units |
|------------|-------------------------------------|---|------|---------------------|---------|---------------|
| V_{IH} | Input HIGH Voltage | Guaranteed Logic HIGH Level | 2.0 | | | V |
| V_{IL} | Input LOW Voltage | Guaranteed Logic LOW Level | -0.5 | | 0.8 | V |
| I_{IH} | Input HIGH Current | $V_{CC} = \text{Max.}, V_{IN} = V_{CC}$ | | | ± 1 | μA |
| I_{IL} | Input LOW Current | $V_{CC} = \text{Max.}, V_{IN} = \text{GND}$ | | | ± 1 | μA |
| I_{OZH} | High Impedance Output Current | $0 \leq A_N, B_N \leq V_{CC}$ | | | ± 1 | μA |
| V_{IK} | Clamp Diode Voltage | $V_{CC} = \text{Min.}, I_{IN} = -18 \text{ mA}$ | | | -1.2 | V |
| R_{ON} | Switch On Resistance ⁽³⁾ | $V_{CC} = \text{Min.}, V_{IN} = 0.0\text{V}, I_{ON} = 48\text{mA}$ or 64mA | | 5 | 8 | Ω |
| | | $V_{CC} = \text{Min.}, V_{IN} = 2.4\text{V}, I_{ON} = 15\text{mA}$ | | 10 | 17 | |

Notes:

- For Max. or Min. conditions, use appropriate value specified under Electrical Characteristics for the applicable device type.
- Typical values are at $V_{CC} = 3.3\text{V}$, $T_A = 25^{\circ}\text{C}$ ambient and maximum loading.
- Measured by the voltage drop between A and B pin at indicated current through the switch. ON resistance is determined by the lower of the voltages on the two (A,B) pins.

Capacitance ($T_A = 25^{\circ}\text{C}$, $f = 1 \text{ MHz}$)

| Parameters ⁽¹⁾ | Description | Test Conditions | Typ. | Units |
|---------------------------|-----------------------------|----------------------|------|-------|
| C_{IN} | Input Capacitance | $V_{IN} = 0\text{V}$ | 3.0 | pF |
| C_{OFF} | A/B Capacitance, Switch Off | $V_{IN} = 0\text{V}$ | 8.0 | pF |
| C_{ON} | A/B Capacitance, Switch On | $V_{IN} = 0\text{V}$ | 16.0 | pF |

Notes:

- This parameter is determined by device characterization but is not production tested.

Power Supply Characteristics

| Parameters | Description | Test Conditions ⁽¹⁾ | | Min. | Typ. ⁽²⁾ | Max. | Units |
|------------------|--------------------------------|--------------------------------|--|------|---------------------|------|-------|
| I _{CC} | Quiescent Power Supply Current | V _{CC} = Max. | V _{IN} = GND or V _{CC} | | 0.1 | 3.0 | μA |
| ΔI _{CC} | Supply Current per Input HIGH | V _{CC} = Max. | V _{IN} = 3.0V ⁽³⁾ | | | 750 | μA |

Notes:

1. For Max. or Min. conditions, use appropriate value specified under Electrical Characteristics for the applicable device.
2. Typical values are at V_{CC} = 3.3V, +25°C ambient.
3. Per TTL driven input (control input only); A and B pins do not contribute to I_{CC}.

Switching Characteristics over Operating Range

| Parameters | Description | Test Conditions | Com. | | Units |
|--------------------------------------|--|-------------------------|------|------|-------|
| | | | Min. | Max. | |
| t _{PLH} t _{PHL} | Propagation Delay ^(1,2) Ax to Bx, Bx to Ax | CL = 50 pF RL = 500Ω | | 0.25 | ns |
| t _{PZH} t _{PZL} | Bus Enable Time BE to Ax or Bx | | 1.0 | 4.0 | |
| t _{PHZ} t _{PLZ} | Bus Disable Time BE to Ax or Bx | | 1.0 | 4.5 | |

Notes:

1. This parameter is guaranteed but not tested on Propagation Delays.
2. The bus switch contributes no propagational delay other than the RC delay of the On-Resistance of the switch and the load capacitance. The time constant for the switch alone is of the order of 0.25 ns for 50 pF load. Since this time constant is much smaller than the rise/fall times of typical driving signals, it adds very little propagational delay to the system. Propagational delay of the bus switch when used in a system is determined by the driving circuit on the driving side of the switch and its interaction with the load on the driven side.

Applications Information

Logic Inputs

The logic control inputs can be driven up to +3.6V regardless of the supply voltage. For example, given a + 3.3V supply, A_N may be driven low to 0V and high to 3.6V. Driving B_N Rail-to-Rail® minimizes power consumption.

Power-Supply Sequencing and Hot-Plug Information

Proper power-supply sequencing is recommended for all CMOS devices. Always apply V_{CC} and GND before applying signals to input/output or control pins.

Rail-to-Rail is a registered trademark of Nippon Motorola, Ltd.

PI3B3245

Part Marking

S Package



YY: Year
WW: Workweek
1st X: Assembly Site Code
2nd X: Wafer Fab Site Code

Q Package

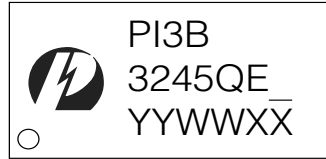

YY: Year
WW: Workweek
1st X: Assembly Site Code
2nd X: Fab Site Code
Bar above fab code means Cu wire
Without bar above fab code means Au wire

L Package

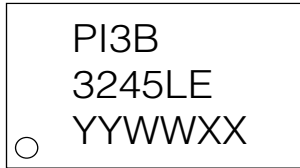

YY: Year
WW: Workweek
1st X: Assembly Code
2nd X: Fab Code

PI3B3245

Packaging Mechanical: 20-SOIC (S)

DOCUMENT CONTROL NO.
PD - 1006

REVISION: D
DATE: 03/09/05

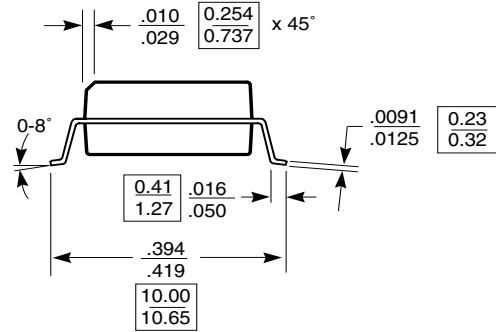
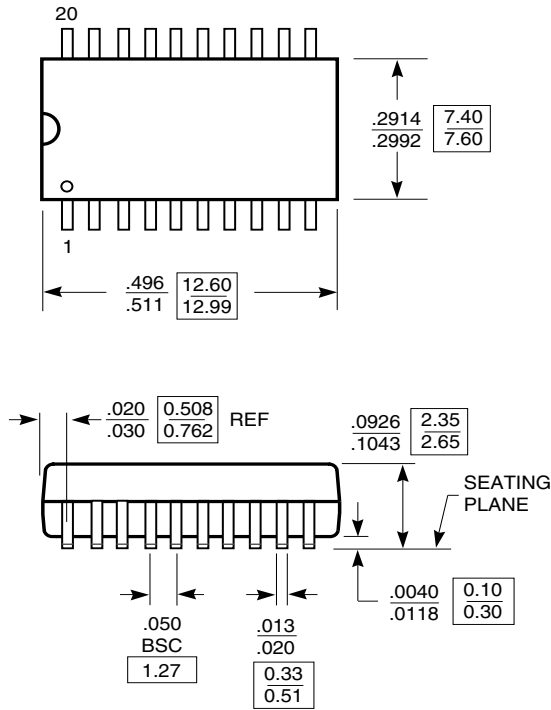

X.XX DENOTES CONTROLLING
X.XX DIMENSIONS IN MILLIMETERS

Notes:
 1) Controlling dimensions in millimeters.
 2) Ref: JEDEC MS-013D/AC



Pericom Semiconductor Corporation
 3545 N. 1st Street, San Jose, CA 95134
 1-800-435-2335 • www.pericom.com

DESCRIPTION: 20-Pin, 300-Mil Wide, SOIC

PACKAGE CODE: S

PI3B3245

Packaging Mechanical: 20-QSOP (Q)

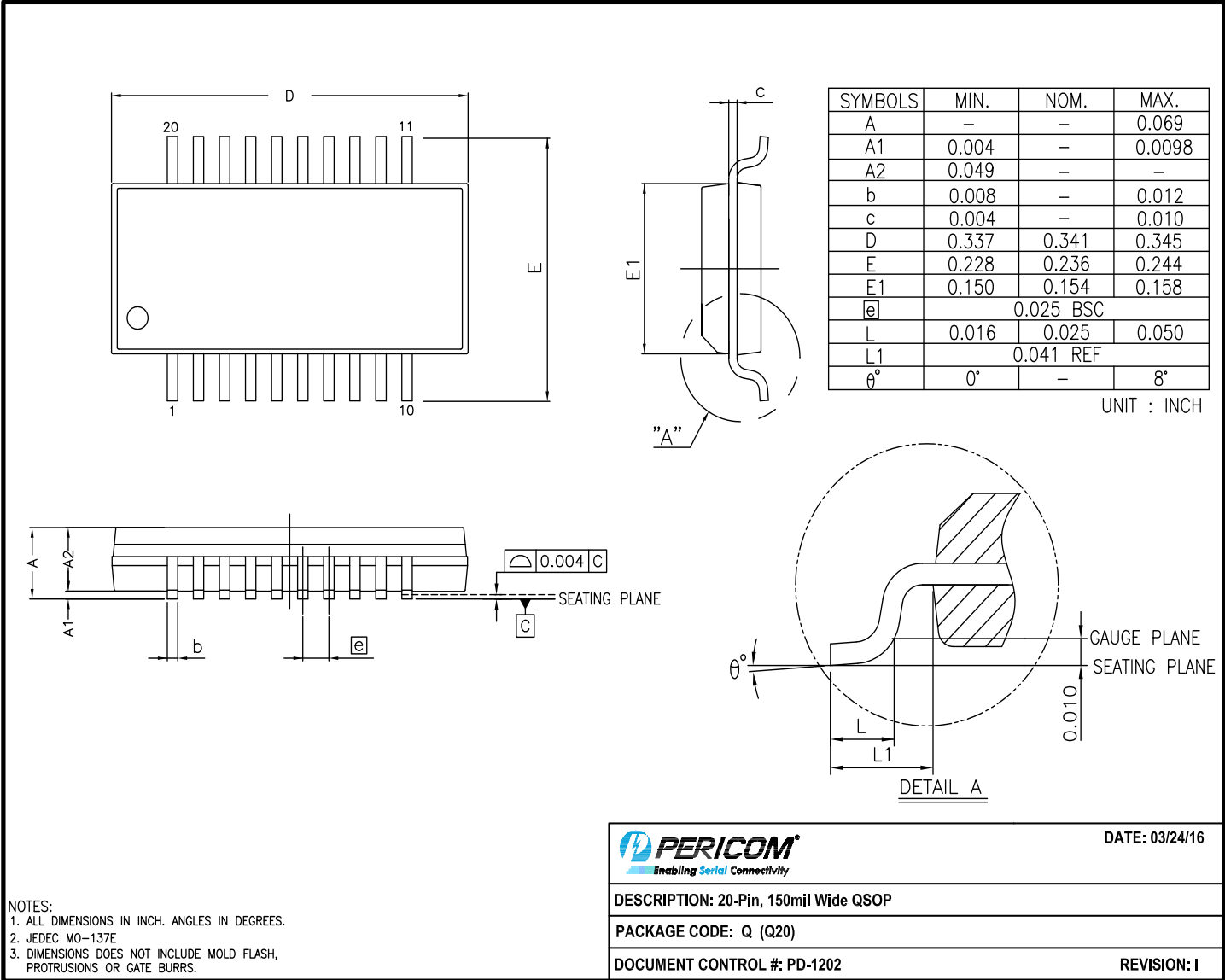

NOTES:
 1. ALL DIMENSIONS IN INCH. ANGLES IN DEGREES.
 2. JEDEC MO-137E
 3. DIMENSIONS DOES NOT INCLUDE MOLD FLASH, PROTRUSIONS OR GATE BURRS.

| | | |
|---------------------------------------|-------------|----------------|
| | | DATE: 03/24/16 |
| DESCRIPTION: 20-Pin, 150mil Wide QSOP | | |
| PACKAGE CODE: Q (Q20) | | |
| DOCUMENT CONTROL #: PD-1202 | REVISION: I | |

16-0057

PI3B3245

Packaging Mechanical: 20-TSSOP (L)

| SYMBOLS | MIN. | NOM. | MAX. |
|----------|----------|------|------|
| A | — | — | 1.20 |
| A1 | 0.05 | — | 0.15 |
| A2 | 0.80 | 1.00 | 1.05 |
| b | 0.19 | — | 0.30 |
| C | 0.09 | — | 0.20 |
| D | 6.40 | 6.50 | 6.60 |
| E1 | 4.30 | 4.40 | 4.50 |
| E | 6.20 | 6.40 | 6.60 |
| e | 0.65 BSC | | |
| L1 | 1.00 REF | | |
| L | 0.45 | 0.60 | 0.75 |
| S | 0.20 | — | — |
| θ | 0° | — | 8° |

NOTES:
 1. ALL DIMENSIONS IN MILLIMETERS. ANGLES IN DEGREES.
 2. JEDEC MO-153F
 3. DIMENSIONS DOES NOT INCLUDE MOLD FLASH, PROTRUSIONS OR GATE BURRS.

| | | |
|--|---------|----------------|
| | | DATE: 03/31/16 |
| DESCRIPTION: 20-Pin, 173mil Wide TSSOP | | |
| PACKAGE CODE: L (L20) | | |
| DOCUMENT CONTROL #: | PD-1311 | REVISION: G |

16-0074

For latest package info.

please check: <http://www.diodes.com/design/support/packaging/pericom-packaging/packaging-mechanicals-and-thermal-characteristics/>

Ordering Information

| Ordering Code | Package Code | Package Type |
|---------------|--------------|-----------------------------|
| PI3B3245SEX | S | 20-pin, 300Mil Wide (SOIC) |
| PI3B3245QEX | Q | 20-pin, 150mil Wide (QSOP) |
| PI3B3245LEX | L | 20-pin, 173mil Wide (TSSOP) |

Notes:

1. No purposely added lead. Fully EU Directive 2002/95/EC (RoHS), 2011/65/EU (RoHS 2) & 2015/863/EU (RoHS 3) compliant.
2. See <https://www.diodes.com/quality/lead-free/> for more information about Diodes Incorporated's definitions of Halogen- and Antimony-free, "Green" and Lead-free.
3. Halogen- and Antimony-free "Green" products are defined as those which contain <900ppm bromine, <900ppm chlorine (<1500ppm total Br + Cl) and <1000ppm antimony compounds.
4. E = Pb-free and Green
5. X suffix = Tape/Reel

IMPORTANT NOTICE

DIODES INCORPORATED MAKES NO WARRANTY OF ANY KIND, EXPRESS OR IMPLIED, WITH REGARDS TO THIS DOCUMENT, INCLUDING, BUT NOT LIMITED TO, THE IMPLIED WARRANTIES OF MERCHANTABILITY AND FITNESS FOR A PARTICULAR PURPOSE (AND THEIR EQUIVALENTS UNDER THE LAWS OF ANY JURISDICTION).

Diodes Incorporated and its subsidiaries reserve the right to make modifications, enhancements, improvements, corrections or other changes without further notice to this document and any product described herein. Diodes Incorporated does not assume any liability arising out of the application or use of this document or any product described herein; neither does Diodes Incorporated convey any license under its patent or trademark rights, nor the rights of others. Any Customer or user of this document or products described herein in such applications shall assume all risks of such use and will agree to hold Diodes Incorporated and all the companies whose products are represented on Diodes Incorporated website, harmless against all damages.

Diodes Incorporated does not warrant or accept any liability whatsoever in respect of any products purchased through unauthorized sales channel.

Should Customers purchase or use Diodes Incorporated products for any unintended or unauthorized application, Customers shall indemnify and hold Diodes Incorporated and its representatives harmless against all claims, damages, expenses, and attorney fees arising out of, directly or indirectly, any claim of personal injury or death associated with such unintended or unauthorized application.

Products described herein may be covered by one or more United States, international or foreign patents pending. Product names and markings noted herein may also be covered by one or more United States, international or foreign trademarks.

This document is written in English but may be translated into multiple languages for reference. Only the English version of this document is the final and definitive format released by Diodes Incorporated.

LIFE SUPPORT

Diodes Incorporated products are specifically not authorized for use as critical components in life support devices or systems without the express written approval of the Chief Executive Officer of Diodes Incorporated. As used herein:

A. Life support devices or systems are devices or systems which:

1. are intended to implant into the body, or

2. support or sustain life and whose failure to perform when properly used in accordance with instructions for use provided in the labeling can be reasonably expected to result in significant injury to the user.

B. A critical component is any component in a life support device or system whose failure to perform can be reasonably expected to cause the failure of the life support device or to affect its safety or effectiveness.

Customers represent that they have all necessary expertise in the safety and regulatory ramifications of their life support devices or systems, and acknowledge and agree that they are solely responsible for all legal, regulatory and safety-related requirements concerning their products and any use of Diodes Incorporated products in such safety-critical, life support devices or systems, notwithstanding any devices- or systems-related information or support that may be provided by Diodes Incorporated. Further, Customers must fully indemnify Diodes Incorporated and its representatives against any damages arising out of the use of Diodes Incorporated products in such safety-critical, life support devices or systems.

Copyright © 2016, Diodes Incorporated

www.diodes.com