

# DESIGN NOTE

## RS-485 Port Protection Evaluation Board 4

### INTRODUCTION

This evaluation board serves as an aid in evaluating circuit protection solutions for RS-485 serial ports. It uses a Bourns® TBU® High-Speed Protector (HSP), a Gas Discharge Tube (GDT) Surge Arrestor and a Transient Voltage Suppressor (TVS) that are designed to meet the required industry standards on RS-485 port interfaces. The recommended Bourns® TBU® HSP solution offers enhanced performance features over competing technologies. These performance features can help engineers improve the surge and transient protection level on RS-485 ports, while allowing them to place the entire circuit protection solution into a smaller PCB area as compared to alternative solutions. The Bourns® RS-485 Evaluation Board 4 measures 35 mm x 25 mm x 0.85 mm, and is manufactured using an FR-4 PCB with nickel-gold pad plating on the top and bottom sides.

Bourns' three previous versions of the RS-485 Evaluation Boards (EVB1, 2 and 3) used the Bourns® Model TBU-CA, which is a single-channel device. Because the RS-485 interface has two lines, this new evaluation board provides further PCB area reduction by utilizing the new Bourns® Model TBU-DF HSP, which is a dual-channel device. This latest evaluation board is the smallest RS-485 evaluation board offering a more compact solution helping designers save valuable PCB real estate.

### HOW TO CONNECT THE EVALUATION BOARD FOR TEST SET-UP

- Connect J1A and J1B to the exposed lines.
- Connect J2A and J2B to the RS-485 IC device.

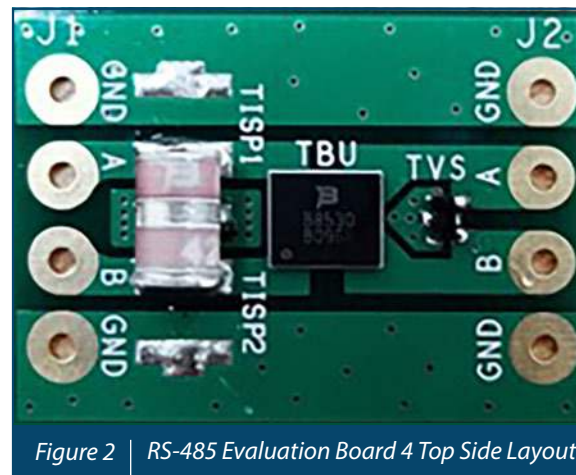
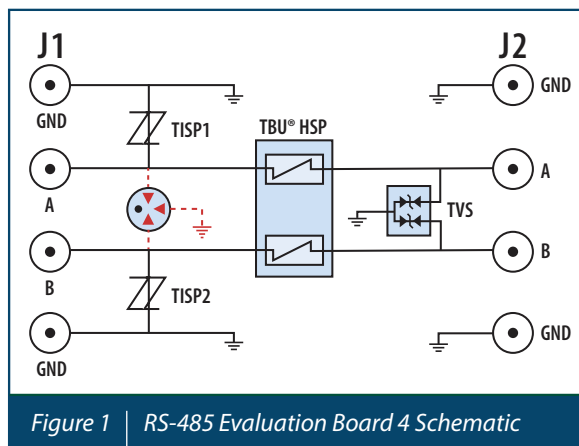

Table 1   RS-485 Evaluation Board 4 Bill of Materials				
No.	Part Number	Qty.	Description	Product
1	TBU-DF085-300-WH	1	850 V 300 mA Dual Channel Bidirectional TBU® HSP	TBU® HSP
2	2030-42T-SM-RPLF	1	Fast Acting, 3-Electrode 420 V Gas Discharge Tube	GDT
3	CDSOT23-SM712	1	SOT23 12 V Dual Bidirectional TVS Diode	TVS Diode

The default configuration of this board uses a TBU® HSP, a GDT and a TVS diode.

The board allows different configurations:

- One Model 2030-42T-SM-RPLF could be replaced by two Model TISP4350J3BJR-S
- One Model 2030-42T-SM-RPLF could be replaced by two Model TISP4500H3BJR-S
- One Model 2030-42T-SM-RPLF could be replaced by one Model 2036-07-SM-RPLF

# RS-485 Port Protection Evaluation Board 4

## RS-485 EVALBOARD 4 CONFIGURATION

Protection of RS-485 ports are typically required in three scenarios. The first scenario is for exposed and harsh environments, such as outdoor installations where induced lightning surges are a threat. Customers for these types of applications are familiar with the ITU-T K.20/21/44 recommendations (specifying the 10/700  $\mu$ s voltage, surge) or with the Telcordia GR-1089-CORE or IEC 61000-4-5 standard (specifying the CWG 8/20  $\mu$ s current, 1.2/50  $\mu$ s voltage surges).

The second scenario accommodates long cable runs where multiple lines (data and AC power) are used in the same trucking or cabling. During a fault incidence, the AC power lines may come in contact with the signal lines. These applications require 230 V<sub>AC</sub> tests specified in ITU-T K.20/21/44, or 120 V<sub>AC</sub> tests specified in Telcordia GR-1089-CORE. There are applications with lower voltage application/installation threats, but where the standardized 120 V<sub>AC</sub> or 230 V<sub>AC</sub> tests are still used to test the robustness of the protection solution.

The third scenario protects against installation errors and faults. For example, 12 V<sub>DC</sub> or 24 V<sub>DC</sub> lines are frequently run together with the signal lines. The cable runs may include other exposed lines that can induce lightning surges onto RS-485 ports. In addition, there is the risk of deliberate and malicious attacks on RS-485 ports by unauthorized users. All of these can typically be taken care of with a protection solution that meets the higher protection levels offered in scenarios one and two.

This evaluation board brief will highlight options for two levels of lightning surges that use a TISP<sup>®</sup> Thyristor Surge Protector for the lower surge level and a GDT for the higher surge level. By varying the chosen voltage, this brief will also demonstrate that AC power cross up to 120 V<sub>AC</sub> or 230 V<sub>AC</sub> can be accommodated by a Bourns<sup>®</sup> Model TBU-DF based RS-485 protection solution.

Table 2 | Bourns<sup>®</sup> TBU<sup>®</sup> High-Speed Protector (HSP) and Overvoltage Protector (OVP) Combination

OVP Part Number	OVP Surge Rating	V <sub>DRM</sub> (V)	V <sub>BO</sub> (V) (1000 V/ $\mu$ s)	TBU <sup>®</sup> HSP Part Number	Surge Capability	AC Power Cross Capability
TISP4350J3BJR-S	800 A, 8/20 $\mu$ s 350 A, 5/310 $\mu$ s	275	350	TBU-DF055-300-WH	IEC61000-4-5, Level 4, 4 kV 1.2/50 $\mu$ s, 42 Ohm	120 V <sub>AC</sub>
2030-42T-SM	500 A, 8/20 $\mu$ s 150 A, 5/310 $\mu$ s	360	850	TBU-DF085-300-WH		230 V <sub>AC</sub>
TISP4500H3BJR-S	200 A, 5/310 $\mu$ s	350	500	TBU-DF055-300-WH	ITU K.20/21/45 Enhanced Lighting, 6 kV 10/700 $\mu$ s, 40 Ohm	230 V <sub>AC</sub>
2036-07-SM	10,000 A, 8/20 $\mu$ s 2,000 A, 5/310 $\mu$ s	75	750	TBU-DF085-300-WH		–

Overvoltage Protector (OVP) Selection:

- Breakover voltage (V<sub>BO</sub>) or impulse breakdown voltage (V<sub>imp</sub>) of the overvoltage protector (OVP) should be below the maximum Peak Impulse Voltage (V<sub>imp</sub>) of the TBU<sup>®</sup> HSP.
- V<sub>BO</sub> or V<sub>imp</sub> of the OVP should be above the maximum voltage of AC power cross (peak of V<sub>AC</sub>).

## SURGE CAPABILITY

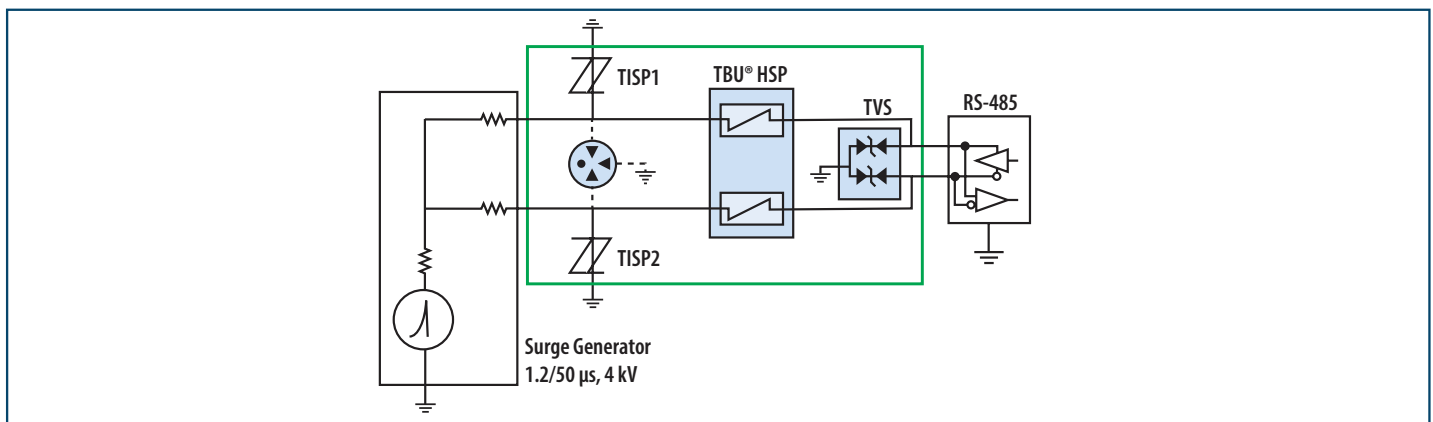

Figure 3 | RS-485 Port Protection Evaluation Board Surge Test Setup

# RS-485 Port Protection Evaluation Board 4

Below are graphs of different surge tests performed on Bourns' RS-485 Evaluation Board 4 based on the various standards requirements.

Table 3 | Test Results for Bourns® TBU® High-Speed Protector (HSP) and Overvoltage Protector (OVP) Combination

TBU® HSP & OVP Combination Products		
1 Bourns® Model TBU-DF055-300-WH	2 Bourns® Model TISP4350J3BJR-S	1 Bourns® Model CDS0T23-SM712
<b>Test Results</b>		
<b>Surge Capability: IEC61000-4-5 Level 4, 4 kV 1.2/50 μs</b>		
<ul style="list-style-type: none"> <li>Upon application of the 4 kV (95.2 A) surge (Channel 2), the transient current flowing through TBU-DF055-300-WH increases to trigger TBU-DF055-300-WH quickly (<math>&lt; 1 \mu\text{s}</math>).</li> <li>When the TBU-DF055-300-WH is in the blocking state, the line voltage (Channel 1) increases with the surge, as there is no current flow into the protected interface.</li> <li>When the line voltage increases to the <math>V_{BO}</math> of TISP4350J3BJR-S (350V), TISP4350J3BJR-S will trigger shunt the line to GND.</li> <li>Hence, the protected interface is only subject to a very low (300 mA) transient current <math>&lt; 1 \mu\text{s}</math> and the interface exposed to a low line voltage of 360 V momentarily.</li> </ul>		

CH1: TISP4350J3BJR-S Voltage CH2: Surge Generator Output Current

TBU® HSP & OVP Combination Products		
1 Bourns® Model TBU-DF055-300-WH	2 Bourns® Model TISP4350J3BJR-S	1 Bourns® Model CDS0T23-SM712
<b>Test Results</b>		
<b>Surge Capability: IEC61000-4-5 Level 4, 6 kV 10/700 μs</b>		
<ul style="list-style-type: none"> <li>Upon application of the 6 kV (150 A) surge (Channel 2), the transient current flowing through TBU-DF055-300-WH increases to trigger TBU-DF055-300-WH quickly (<math>&lt; 1 \mu\text{s}</math>).</li> <li>When the TBU-DF055-300-WH is in the blocking state, the line voltage (Channel 1) increases with the surge, as there is no current flow into the protected interface.</li> <li>When the line voltage increases to the <math>V_{BO}</math> of TISP4350J3BJR-S (350 V), TISP4350J3BJR-S will trigger shunt the line to GND.</li> <li>Hence, the protected interface is only subject to a very low (300 mA) transient current <math>&lt; 1 \mu\text{s}</math> and the interface exposed to a low line voltage of 352 V momentarily.</li> </ul>		

CH1: TISP4350J3BJR-S Voltage CH2: Surge Generator Output Current

Table 4 | Test Results for Bourns® TBU® High-Speed Protector (HSP) and Overvoltage Protector (OVP) Combination

TBU® HSP & OVP Combination Products		
1 Bourns® Model TBU-DF085-300-WH	1 Bourns® Model 2030-42T-SM-RPLF	1 Bourns® Model CDS0T23-SM712
<b>Test Results</b>		
<b>Surge Capability: IEC61000-4-5 Level 4, 4 kV 1.2/50 μs</b>		
<ul style="list-style-type: none"> <li>Upon application of the 4 kV (95.2 A) surge (Channel 2), the transient current flowing through TBU-DF085-300-WH increases to trigger TBU-DF085-300-WH quickly (<math>&lt; 1 \mu\text{s}</math>).</li> <li>When the TBU-DF085-300-WH is in the blocking state, the line voltage (Channel 1) increases with the surge, as there is no current flow into the protected interface.</li> <li>When the line voltage increases to the <math>V_{BO}</math> of 2030-42T-SM (850 V), 2030-42T-SM will trigger shunt the line to GND.</li> <li>Hence, the protected interface is only subject to a very low (300 mA) transient current <math>&lt; 1 \mu\text{s}</math> and the interface exposed to a low line voltage of 820 V momentarily.</li> </ul>		

CH1: 2030-42T-SM-RPLF Voltage CH2: Surge Generator Output Current

TBU® HSP & OVP Combination Products		
1 Bourns® Model TBU-DF085-300-WH	1 Bourns® Model 2030-42T-SM-RPLF	1 Bourns® Model CDS0T23-SM712
<b>Test Results</b>		
<b>Surge Capability: IEC61000-4-5 Level 4, 6 kV 10/700 μs</b>		
<ul style="list-style-type: none"> <li>Upon application of the 6 kV (150 A) surge (Channel 2), the transient current flowing through TBU-DF085-300-WH increases to trigger TBU-DF085-300-WH quickly (<math>&lt; 1 \mu\text{s}</math>).</li> <li>When the TBU-DF085-300-WH is in the blocking state, the line voltage (Channel 1) increases with the surge, as there is no current flow into the protected interface.</li> <li>When the line voltage increases to the <math>V_{BO}</math> of 2030-42T-SM (850 V), 2030-42T-SM will trigger shunt the line to GND.</li> <li>Hence, the protected interface is only subject to a very low (300 mA) transient current <math>&lt; 1 \mu\text{s}</math> and the interface exposed to a low line voltage of 560 V momentarily.</li> </ul>		

CH1: 2030-42T-SM-RPLF Voltage CH2: Surge Generator Output Current

# RS-485 Port Protection Evaluation Board 4

Table 5 Test Results for Bourns® TBU® High-Speed Protector (HSP) and Overvoltage Protector (OVP) Combination

TBU® HSP & OVP Combination Products		
1 Bourns® Model TBU-DF055-300-WH	2 Bourns® Model TISP4500H3BJR-S	1 Bourns® Model CDS0T23-SM712
<b>Test Results</b>		
<b>Surge Capability: IEC61000-4-5 Level 4, 4 kV 1.2/50 µs</b>		
<p>Measure</p> <ul style="list-style-type: none"> <li>Vpp: 1: 496V, 2: 96.0A</li> <li>Vavg: 1: -8.20V, 2: 45.8A</li> <li>Frequency: 1: ?, 2: ?</li> <li>Duty Cycle: 1: ?, 2: ?</li> <li>Rise Time: 1: 34.24ns, 2: 2.428µs</li> </ul> <p>CH1: TISP4500H3BJR-S Voltage CH2: Surge Generator Output Current</p>	<ul style="list-style-type: none"> <li>Upon application of the 4 kV (95.2 A) surge (Channel 2), the transient current flowing through TBU-DF055-300-WH increases to trigger TBU-DF055-300-WH quickly (&lt;1 µs).</li> <li>When the TBU-DF055-300-WH is in the blocking state, the line voltage (Channel 1) increases with the surge, as there is no current flow into the protected interface.</li> <li>When the line voltage increases to the <math>V_{BO}</math> of TISP4500H3BJR-S (500 V), TISP4500H3BJR-S will trigger shunt the line to GND.</li> <li>Hence, the protected interface is only subject to a very low (300 mA) transient current &lt;1 µs and the interface exposed to a low line voltage of 496 V momentarily.</li> </ul>	

TBU® HSP & OVP Combination Products		
1 Bourns® Model TBU-DF055-300-WH	2 Bourns® Model TISP4500H3BJR-S	1 Bourns® Model CDS0T23-SM712
<b>Test Results</b>		
<b>Surge Capability: IEC61000-4-5 Level 4, 6 kV 10/700 µs</b>		
<p>Measure</p> <ul style="list-style-type: none"> <li>Vpp: 1: 464V, 2: 154A</li> <li>Vavg: 1: -7.59V, 2: 57.6A</li> <li>Frequency: 1: ?, 2: ?</li> <li>Duty Cycle: 1: ?, 2: ?</li> <li>Rise Time: 1: 328.0ns, 2: 3.669µs</li> </ul> <p>CH1: TISP4500H3BJR-S Voltage CH2: Surge Generator Output Current</p>	<ul style="list-style-type: none"> <li>Upon application of the 6 kV (150 A) surge (Channel 2), the transient current flowing through TBU-DF055-300-WH increases to trigger TBU-DF055-300-WH quickly (&lt;1 µs).</li> <li>When the TBU-DF055-300-WH is in the blocking state, the line voltage (Channel 1) increases with the surge, as there is no current flow into the protected interface.</li> <li>When the line voltage increases to the <math>V_{BO}</math> of TISP4500H3BJR-S (500 V), TISP4500H3BJR-S will trigger shunt the line to GND.</li> <li>Hence, the protected interface is only subject to a very low (300 mA) transient current &lt;1 µs and the interface exposed to a low line voltage of 464 V momentarily.</li> </ul>	

Table 6 Test Results for Bourns® TBU® High-Speed Protector (HSP) and Overvoltage Protector (OVP) Combination

TBU® HSP & OVP Combination Products		
1 Bourns® Model TBU-DF085-300-WH	1 Bourns® Model 2036-07-SM-RPLF	1 Bourns® Model CDS0T23-SM712
<b>Test Results</b>		
<b>Surge Capability: IEC61000-4-5 Level 4, 4 kV 1.2/50 µs</b>		
<p>Measure</p> <ul style="list-style-type: none"> <li>Vpp: 1: 648V, 2: 96.0A</li> <li>Vavg: 1: 3.33V, 2: 45.1A</li> <li>Frequency: 1: ?, 2: ?</li> <li>Duty Cycle: 1: ?, 2: ?</li> <li>Rise Time: 1: ?, 2: 2.168µs</li> </ul> <p>CH1: 2036-07-SM-RPLF Voltage CH2: Surge Generator Output Current</p>	<ul style="list-style-type: none"> <li>Upon application of the 4 kV (95.2 A) surge (Channel 2), the transient current flowing through TBU-DF085-300-WH increases to trigger TBU-DF085-300-WH quickly (&lt;1 µs).</li> <li>When the TBU-DF085-300-WH is in the blocking state, the line voltage (Channel 1) increases with the surge, as there is no current flow into the protected interface.</li> <li>When the line voltage increases to the <math>V_{BO}</math> of 2036-07-SM (750 V), 2036-07-SM will trigger shunt the line to GND.</li> <li>Hence, the protected interface is only subject to a very low (300 mA) transient current &lt;1 µs and the interface exposed to a low line voltage of 648 V momentarily.</li> </ul>	

TBU® HSP & OVP Combination Products		
1 Bourns® Model TBU-DF085-300-WH	1 Bourns® Model 2036-07-SM-RPLF	1 Bourns® Model CDS0T23-SM712
<b>Test Results</b>		
<b>Surge Capability: IEC61000-4-5 Level 4, 6 kV 10/700 µs</b>		
<p>Measure</p> <ul style="list-style-type: none"> <li>Vpp: 1: 592V, 2: 150A</li> <li>Vavg: 1: -219mV, 2: 57.5A</li> <li>Frequency: 1: ?, 2: ?</li> <li>Duty Cycle: 1: ?, 2: ?</li> <li>Rise Time: 1: ?, 2: 4.452µs</li> </ul> <p>CH1: 2036-07-SM-RPLF Voltage CH2: Surge Generator Output Current</p>	<ul style="list-style-type: none"> <li>Upon application of the 6 kV (150 A) surge (Channel 2), the transient current flowing through TBU-DF085-300-WH increases to trigger TBU-DF085-300-WH quickly (&lt;1 µs).</li> <li>When the TBU-DF085-300-WH is in the blocking state, the line voltage (Channel 1) increases with the surge, as there is no current flow into the protected interface.</li> <li>When the line voltage increases to the <math>V_{BO}</math> of 2036-07-SM (750 V), 2036-07-SM will trigger shunt the line to GND.</li> <li>Hence, the protected interface is only subject to a very low (300 mA) transient current &lt;1 µs and the interface exposed to a low line voltage of 592 V momentarily.</li> </ul>	

## RS-485 Port Protection Evaluation Board 4

### AC POWER CROSS CAPABILITY

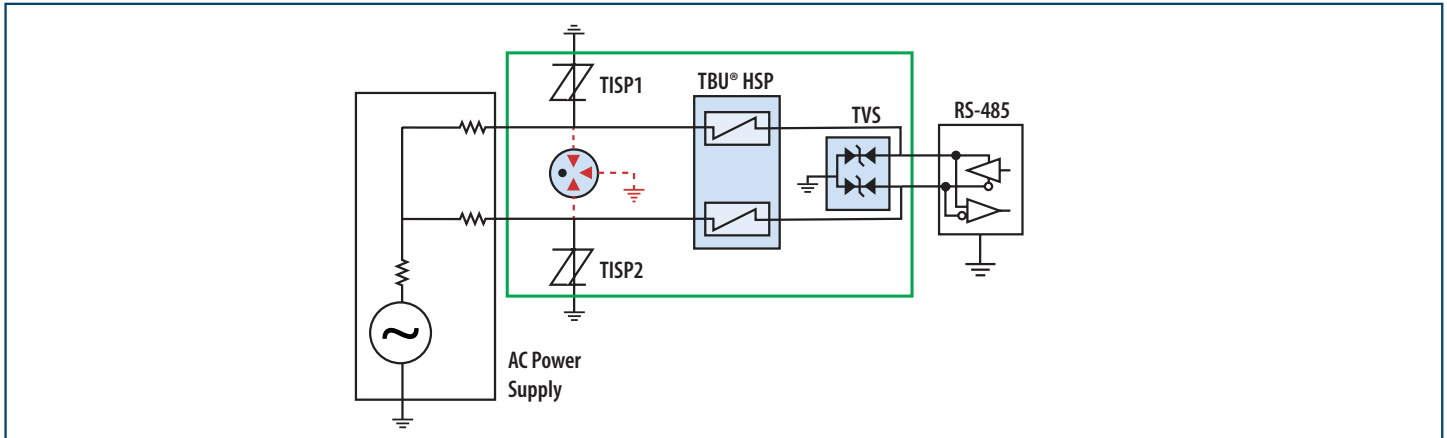

Figure 3 | RS-485 Port Protection Evaluation Board AC Power Cross Test Setup

Table 7 | Test Results for Bourns® TBU® High-Speed Protector (HSP) and Overvoltage Protector (OVP) Combination

TBU® HSP & OVP Combination Products		
1 Bourns® Model TBU-DF055-300-WH	2 Bourns® Model TISP4350J3BJR-S	1 Bourns® Model CDS0T23-SM712
<b>Surge Capability: AC Power Cross 120 V<sub>AC</sub></b>		
<p><b>Test Results</b></p>	<ul style="list-style-type: none"> <li>Bourns® Model TISP4350J3BJR-S will not be triggered since the peak voltage of 120 V<sub>AC</sub> is less than the V<sub>BO</sub> of Bourns® Model TISP4350J3BJR-S. As a result, Bourns® Model TISP4350J3BJR-S (350 V) will maintain high impedance.</li> <li>When the AC power is applied and the line voltage (Channel 1) and line current (Channel 2) increases, Bourns® Model TBU-DF055-300-WH triggers quickly into the blocking state when the line current reaches its I<sub>TRIGGER</sub> (300 mA), preventing current flow into the protected port. This can be seen as the line current (Channel 2) drops to 0 mA after the Bourns® Model TBU-DF055-300-WH triggers.</li> <li>Once the AC voltage ramps down below V<sub>reset</sub>, Bourns® Model TBU-DF055-300-WH will reset to the conductive state and allow current flow again.</li> </ul>	

CH1: A TBU Voltage CH2: CH2: Line A TBU Current

[www.bourns.com](http://www.bourns.com)

**BOURNS®**

Americas: Tel +1-951-781-5500  
Email [americus@bourns.com](mailto:americus@bourns.com)

EMEA: Tel +36 88 520 390  
Email [eurocus@bourns.com](mailto:eurocus@bourns.com)

Asia-Pacific: Tel +886-2 256 241 17  
Email [asiacus@bourns.com](mailto:asiacus@bourns.com)

COPYRIGHT© 2018 - BOURNS, INC. - 8/28 - e/K1901A

"TBU" is a registered trademark of Bourns, Inc. in the U.S. and other countries, except Japan. All references to TBU™ in this document for use in Japan shall be deemed to be replaced with Bourns® TBU™.  
"Bourns" and "TISP" are registered trademarks of Bourns, Inc. in the U.S. and other countries.