

# ON Semiconductor

## Is Now

# onsemi™

To learn more about onsemi™, please visit our website at  
[www.onsemi.com](http://www.onsemi.com)

---

**onsemi** and **onsemi** and other names, marks, and brands are registered and/or common law trademarks of Semiconductor Components Industries, LLC dba "**onsemi**" or its affiliates and/or subsidiaries in the United States and/or other countries. **onsemi** owns the rights to a number of patents, trademarks, copyrights, trade secrets, and other intellectual property. A listing of **onsemi** product/patent coverage may be accessed at [www.onsemi.com/site/pdf/Patent-Marking.pdf](http://www.onsemi.com/site/pdf/Patent-Marking.pdf). **onsemi** reserves the right to make changes at any time to any products or information herein, without notice. The information herein is provided "as-is" and **onsemi** makes no warranty, representation or guarantee regarding the accuracy of the information, product features, availability, functionality, or suitability of its products for any particular purpose, nor does **onsemi** assume any liability arising out of the application or use of any product or circuit, and specifically disclaims any and all liability, including without limitation special, consequential or incidental damages. Buyer is responsible for its products and applications using **onsemi** products, including compliance with all laws, regulations and safety requirements or standards, regardless of any support or applications information provided by **onsemi**. "Typical" parameters which may be provided in **onsemi** data sheets and/or specifications can and do vary in different applications and actual performance may vary over time. All operating parameters, including "Typicals" must be validated for each customer application by customer's technical experts. **onsemi** does not convey any license under any of its intellectual property rights nor the rights of others. **onsemi** products are not designed, intended, or authorized for use as a critical component in life support systems or any FDA Class 3 medical devices or medical devices with a same or similar classification in a foreign jurisdiction or any devices intended for implantation in the human body. Should Buyer purchase or use **onsemi** products for any such unintended or unauthorized application, Buyer shall indemnify and hold **onsemi** and its officers, employees, subsidiaries, affiliates, and distributors harmless against all claims, costs, damages, and expenses, and reasonable attorney fees arising out of, directly or indirectly, any claim of personal injury or death associated with such unintended or unauthorized use, even if such claim alleges that **onsemi** was negligent regarding the design or manufacture of the part. **onsemi** is an Equal Opportunity/Affirmative Action Employer. This literature is subject to all applicable copyright laws and is not for resale in any manner. Other names and brands may be claimed as the property of others.

# CS5112

## 1.4 A Switching Regulator with 5.0 V, 100 mA Linear Regulator with Watchdog, RESET and ENABLE

The CS5112 is a dual output power supply integrated circuit. It contains a 5.0 V  $\pm$  2%, 100 mA linear regulator, a watchdog timer, a linear output voltage monitor to provide a Power On Reset (POR) and a 1.4 A current mode PWM switching regulator.

The 5.0 V linear regulator is comprised of an error amplifier, reference, and supervisory functions. It has low internal supply current consumption and provides 1.2 V (typical) dropout voltage at maximum load current.

The watchdog timer circuitry monitors an input signal (WDI) from the microprocessor. It responds to the falling edge of this watchdog signal. If a correct watchdog signal is not received within the externally programmable time, a reset signal is issued.

The externally programmable active reset circuit operates correctly for an output voltage ( $V_{LIN}$ ) as low as 1.0 V. During power up, or if the output voltage shifts below the regulation limit, RESET toggles low and remains low for the duration of the delay after proper output voltage regulation is restored. Additionally a reset pulse is issued if the correct watchdog is not received within the programmed time. Reset pulses continue until the correct watchdog signal is received. The reset pulse width and frequency, as well as the Power On Reset delay, are set by one external RC network.

The current mode PWM switching regulator is comprised of an error amplifier with selectable feedback inputs, a current sense amplifier, an adjustable oscillator, and a 1.4 A output power switch with anti-saturation control. The switching regulator can be configured in a variety of topologies.

The CS5112 is load dump capable and has protection circuitry which includes current limit on the linear and switcher outputs, and an overtemperature limiter.

### Features

- Linear Regulator
  - ◆ 5.0 V  $\pm$  2% @ 100 mA
- Switching Regulator
  - ◆ 1.4 A Peak Internal Switch
  - ◆ 120 kHz Maximum Switching Frequency
  - ◆ 5.0 V to 26 V Operating Supply Range
- Smart Functions
  - ◆ Watchdog
  - ◆ RESET
  - ◆ ENABLE
- Protection
  - ◆ Overtemperature
  - ◆ Current Limit
- Internally Fused Leads in a SOIC Package
- Pb-Free Packages are Available\*

\*For additional information on our Pb-Free strategy and soldering details, please download the ON Semiconductor Soldering and Mounting Techniques Reference Manual, SOLDERRM/D.



ON Semiconductor®

<http://onsemi.com>

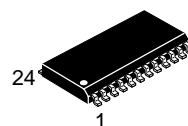

SOIC-24  
DWF SUFFIX  
CASE 751E

### MARKING DIAGRAM

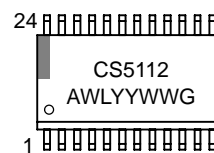

CS5112 = Device Code  
 A = Assembly Location  
 WL = Wafer Lot  
 YY = Year  
 WW = Work Week  
 G = Pb-Free Package

### PIN CONNECTIONS

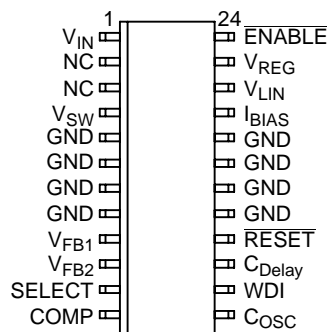

### ORDERING INFORMATION

Device	Package	Shipping†
CS5112YDWF24	SOIC-24	30 Units/Rail
CS5112YDWF24G	SOIC-24 (Pb-Free)	30 Units/Rail
CS5112YDWFR24	SOIC-24	1000/Tape & Reel
CS5112YDWFR24G	SOIC-24 (Pb-Free)	1000/Tape & Reel

†For information on tape and reel specifications, including part orientation and tape sizes, please refer to our Tape and Reel Packaging Specifications Brochure, BRD8011/D.

# CS5112

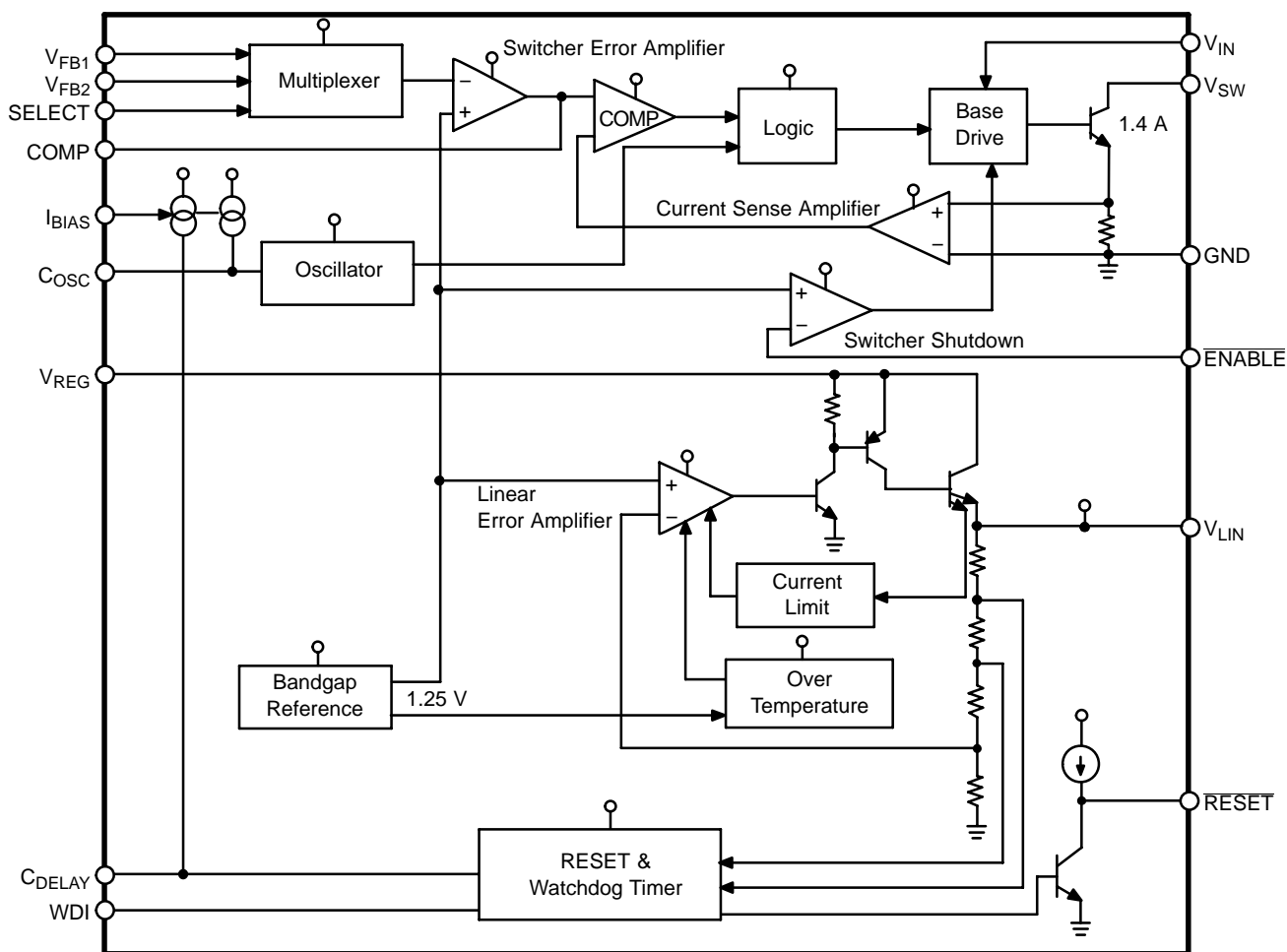

Figure 1. Block Diagram

## MAXIMUM RATINGS

Rating	Value	Unit	
Logic Inputs/Outputs (ENABLE, SELECT, WDI, RESET)	-0.3 to $V_{LIN}$	V	
$V_{LIN}$	-0.3 to 10		
$V_{IN}$ , $V_{REG}$ :	DC Input Voltage	-0.3 to 26	V
	Peak Transient Voltage (26 V Load Dump @ 14 V $V_{IN}$ )	-0.3 to 40	V
$V_{SW}$ Peak Transient Voltage	54	V	
$C_{OSC}$ , $C_{Delay}$ , COMP, $V_{FB1}$ , $V_{FB2}$	-0.3 to $V_{LIM}$	V	
Power Dissipation	Internally Limited	-	
$V_{LIN}$ Output Current	Internally Limited	-	
$V_{SW}$ Output Current	Internally Limited	-	
RESET Output Sink Current	5.0	mA	
ESD Susceptibility (Human Body Model)	2.0	kV	
ESD Susceptibility (Machine Model)	200	V	
Storage Temperature	-65 to 150	°C	
Lead Temperature Soldering:	Reflow: (SMD styles only) (Note 1)	230 peak	°C

Maximum ratings are those values beyond which device damage can occur. Maximum ratings applied to the device are individual stress limit values (not normal operating conditions) and are not valid simultaneously. If these limits are exceeded, device functional operation is not implied, damage may occur and reliability may be affected.

1. 60 second maximum above 183°C.

# CS5112

**ELECTRICAL CHARACTERISTICS** ( $5.0\text{ V} \leq V_{IN} \leq 26\text{ V}$  and  $-40^\circ\text{C} \leq T_J \leq 150^\circ\text{C}$ ,  $C_{OUT} = 100\ \mu\text{F}$  (ESR  $\leq 8.0\ \Omega$ ),  $C_{Delay} = 0.1\ \mu\text{F}$ ,  $R_{BIAS} = 64.9\ \text{k}\Omega$ ,  $C_{OSC} = 390\ \text{pF}$ ,  $C_{COMP} = 0.1\ \mu\text{F}$ ; unless otherwise specified.)

Characteristic	Test Conditions	Min	Typ	Max	Unit
----------------	-----------------	-----	-----	-----	------

## General

$I_{IN}$ Off Current	$6.6\text{ V} \leq V_{IN} \leq 26\text{ V}$ , $I_{SW} = 0\text{ A}$	–	–	2.0	mA
$I_{IN}$ On Current	$6.6\text{ V} \leq V_{IN} \leq 26\text{ V}$ , $I_{SW} = 1.4\text{ A}$	–	30	70	mA
$I_{REG}$ Current	$I_{LIN} = 100\text{ mA}$ , $6.6\text{ V} \leq V_{IN} \leq 26\text{ V}$	–	–	6.0	mA
Thermal Limit	Guaranteed by Design	160	–	210	$^\circ\text{C}$

## 5.0 V Regulator Section

$V_{LIN}$ Output Voltage	$6.6\text{ V} \leq V_{REG} \leq 26\text{ V}$ , $1.0\text{ mA} \leq I_{LIN} \leq 100\text{ mA}$	4.9	5.0	5.1	V
Dropout Voltage	$(V_{REG} - V_{LIN})$ @ $I_{LIN} = 100\text{ mA}$	–	1.2	1.5	V
Line Regulation	$6.6\text{ V} \leq V_{REG} \leq 26\text{ V}$ , $I_{LIN} = 5.0\text{ mA}$	–	5.0	25	mV
Load Regulation	$V_{REG} = 19\text{ V}$ , $1.0\text{ mA} \leq I_{LIN} \leq 100\text{ mA}$	–	5.0	25	mV
Current Limit	$6.6\text{ V} \leq V_{REG} \leq 26\text{ V}$	120	–	–	mA
DC Ripple Rejection	$14\text{ V} \leq V_{REG} \leq 24\text{ V}$	60	75	–	dB

## RESET Section

Low Threshold ( $V_{RTL}$ )	$V_{LIN}$ Decreasing	4.05	4.25	4.45	V
High Threshold ( $V_{RTH}$ )	$V_{LIN}$ Increasing	4.2	4.45	4.7	V
Hysteresis	$V_{RTH} - V_{RTL}$	140	190	240	mV
Active High	$V_{LIN} > V_{RTH}$ , $I_{RESET} = -25\ \mu\text{A}$	$V_{LIN} - 0.5$	–	–	V
Active Low	$V_{LIN} = 1.0\text{ V}$ , $10\ \text{k}\Omega$ Pullup from $\overline{\text{RESET}}$ to $V_{LIN}$ $V_{LIN} = 4.0\text{ V}$ , $I_{RESET} = 1.0\text{ mA}$	– –	– –	0.4 0.7	V V
Delay	Invalid WDI	6.25	8.78	11	ms
Power On Delay	$V_{LIN}$ Crossing $V_{RTH}$	6.25	–	–	ms

## Watchdog Input (WDI)

$V_{IH}$	Peak WDI Needed to Activate $\overline{\text{RESET}}$	–	–	2.0	V
$V_{IL}$	–	0.8	–	–	V
Hysteresis	(Note 2)	25	50	–	mV
Pullup Resistor	WDI = 0 V	20	50	100	$\text{k}\Omega$
Low Threshold	–	6.25	8.78	11	ms
Floating Input Voltage	–	3.5	–	–	V
WDI Pulse Width	–	–	–	5.0	$\mu\text{s}$

## Switcher Section

Minimum Operating Input Voltage	–	–	–	5.0	V
Switching Frequency	Refer to Figure 5	80	95	110	kHz
Switch Saturation Voltage	$I_{SW} = 1.4\text{ A}$	0.7	1.1	1.6	V
Output Current Limit	–	1.4	–	2.5	A
Max Switching Frequency	$V_{SW} = 7.5\text{ V}$ with $50\ \Omega$ Load, Refer to Figure 5	120	–	–	kHz
$V_{FB1}$ Regulation Voltage	–	1.206	1.25	1.294	V
$V_{FB2}$ Regulation Voltage	–	1.206	1.25	1.294	V
$V_{FB1}$ , $V_{FB2}$ Input Current	$V_{FB1} = V_{FB2} = 5.0\text{ V}$	–	–	1.0	$\mu\text{A}$
Oscillator Charge Current	$C_{OSC} = 0\text{ V}$	35	40	45	$\mu\text{A}$
Oscillator Discharge Current	$C_{OSC} = V40$	270	320	370	$\mu\text{A}$
$C_{Delay}$ Charge Current	$C_{Delay} = 0\text{ V}$	35	40	45	$\mu\text{A}$

2. Guaranteed by design, not 100% tested in productions.

# CS5112

**ELECTRICAL CHARACTERISTICS** ( $5.0\text{ V} \leq V_{IN} \leq 26\text{ V}$  and  $-40^\circ\text{C} \leq T_J \leq 150^\circ\text{C}$ ,  $C_{OUT} = 100\ \mu\text{F}$  (ESR  $\leq 8.0\ \Omega$ ),  $C_{Delay} = 0.1\ \mu\text{F}$ ,  $R_{BIAS} = 64.9\ \text{k}\Omega$ ,  $C_{OSC} = 390\ \text{pF}$ ,  $C_{COMP} = 0.1\ \mu\text{F}$ ; unless otherwise specified.)

Characteristic	Test Conditions	Min	Typ	Max	Unit
<b>Switcher Section (continued)</b>					
Switcher Max Duty Cycle	$V_{SW} = 5.0\text{ V}$ with $50\ \Omega$ Load, $V_{FB1} = V_{FB2} = 1.0\text{ V}$	72	85	95	%
Current Sense Amp Gain	$I_{SW} = 2.3\text{ A}$	–	7.0	–	V/V
Error Amp DC Gain	–	–	67	–	dB
Error Amp Transconductance	–	–	2700	–	$\mu\text{A/V}$

## ENABLE Input

VIL	–	0.8	1.24	–	V
VIH	–	–	1.3	2.0	V
Hysteresis	–	–	60	–	mV
Input Impedance	–	10	20	40	$\text{k}\Omega$

## Select Input

VIL (Selects $V_{FB1}$ )	$4.9 \leq V_{LIN} \leq 5.1$	0.8	1.25	–	V
VIH (Selects $V_{FB2}$ )	$4.9 \leq V_{LIN} \leq 5.1$	–	1.25	2.0	V
SELECT Pullup	SELECT = 0 V	10	24	50	$\text{k}\Omega$
Floating Input Voltage	–	3.5	4.5	–	V

## PIN FUNCTION DESCRIPTION

PACKAGE PIN # SOIC-24	PIN SYMBOL	FUNCTION
1	$V_{IN}$	Supply voltage.
2, 3	NC	No connection.
4	$V_{SW}$	Collector of NPN power switch for switching regulator section.
5, 6, 7, 8, 17, 18, 19, 20	GND	Connected to the heat removing leads.
9	$V_{FB1}$	Feedback input voltage 1 (referenced to 1.25 V).
10	$V_{FB2}$	Feedback input voltage 2 (referenced to 1.25 V).
11	SELECT	Logic level input that selects either $V_{FB1}$ or $V_{FB2}$ . An open selects $V_{FB2}$ . Connect to GND to select $V_{FB1}$ .
12	COMP	Output of the transconductance error amplifier.
13	$C_{OSC}$	A capacitor connected to GND sets the switching frequency. Refer to Figure 5.
14	WDI	Watchdog input. Active on falling edge.
15	$C_{Delay}$	A capacitor connected to GND sets the Power On Reset and Watchdog time.
16	RESET	RESET output. Active low if $V_{LIN}$ is below the regulation limit. If watchdog timeout is reached, a reset pulse train is issued.
21	$I_{BIAS}$	A resistor connected to GND sets internal bias currents as well as the $C_{OSC}$ and $C_{Delay}$ charge currents.
22	$V_{LIN}$	Regulated 5.0 V output from the linear regulator section.
23	$V_{REG}$	Input voltage to the linear regulator and the internal supply circuitry.
24	ENABLE	Logic level input to shut down the switching regulator.

TYPICAL PERFORMANCE CHARACTERISTICS

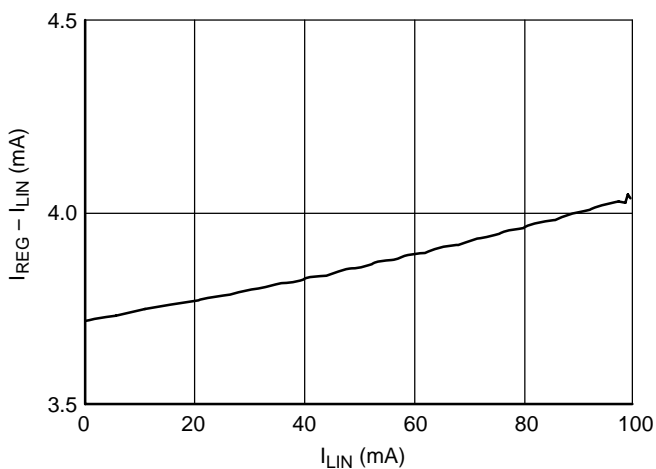

Figure 2. 5.0 V Regulator Bias Current vs. Load Current

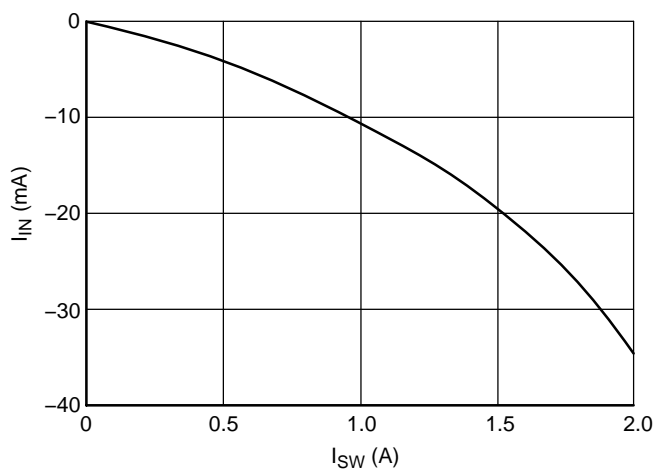

Figure 3. Supply Current vs. Switch Current

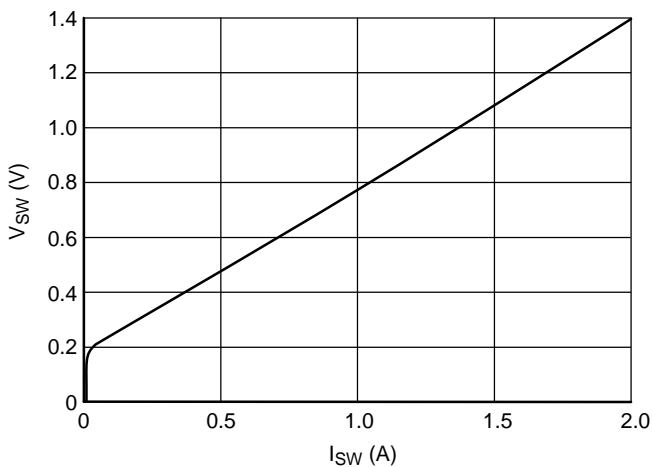

Figure 4. Switch Saturation Voltage

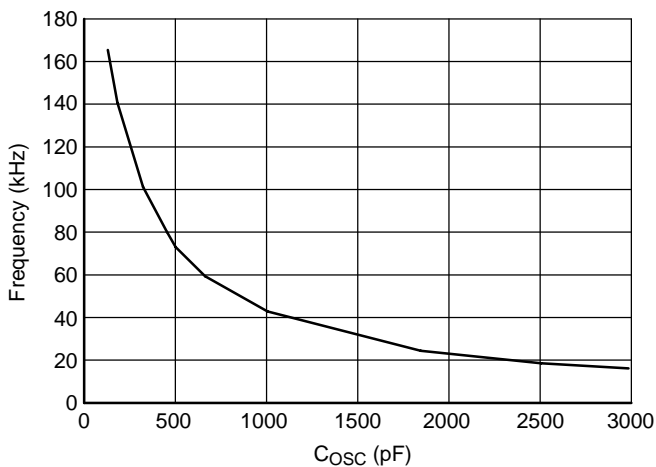

Figure 5. Oscillator Frequency (kHz) vs.  $C_{OSC}$  (pF), Assuming  $R_{BIAS} = 64.9 \text{ k}\Omega$

CIRCUIT DESCRIPTION

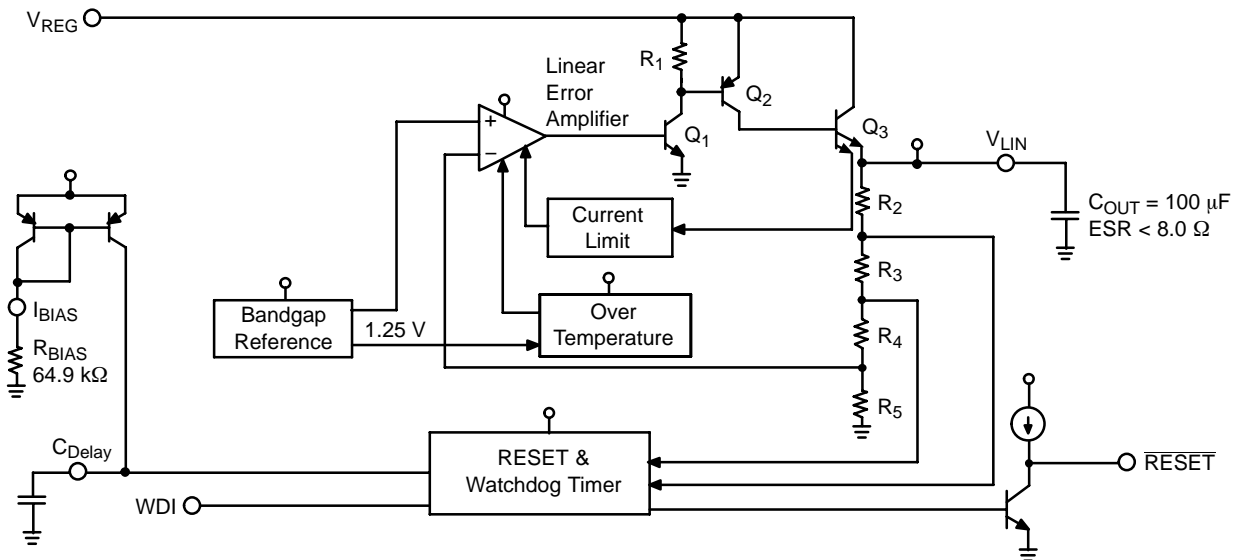

Figure 6. Block Diagram of 5.0 V Linear Regulator Portion of the CS5112

5.0 V LINEAR REGULATOR

The 5.0 V linear regulator consists of an error amplifier, bandgap voltage reference, and a composite pass transistor.

The 5.0 V linear regulator circuitry is shown in Figure 6. When an unregulated voltage greater than 6.6 V is applied to the V<sub>REG</sub> input, a 5.0 V regulated DC voltage will be present at V<sub>LIN</sub>. For proper operation of the 5.0 V linear regulator, the I<sub>BIAS</sub> lead must have a 64.9 kΩ pull down resistor to ground. A 100 μF or larger capacitor with an ESR < 8.0 Ω must be connected between V<sub>LIN</sub> and ground. To operate the 5.0 V linear regulator as an independent regulator (i.e. separate from the switching supply), the input voltage must be tied to the V<sub>REG</sub> lead.

As the voltage at the V<sub>REG</sub> input is increased, Q<sub>1</sub> is turned on. Q<sub>1</sub> provides base drive for Q<sub>2</sub> which in turn provides base current for Q<sub>3</sub>. As Q<sub>3</sub> is turned on, the output voltage, V<sub>LIN</sub>, begins to rise as Q<sub>3</sub>'s output current charges the output capacitor, C<sub>OUT</sub>. Once V<sub>LIN</sub> rises to a certain level, the error amplifier becomes biased and provides the appropriate amount of base current to Q<sub>1</sub>. The error amplifier monitors the scaled output voltage via an internal voltage divider, R<sub>2</sub> through R<sub>5</sub>, and compares it to the bandgap voltage reference. The error amplifier output or error signal is an output current equal to the error amplifier's input differential voltage times the transconductance of the amplifier. Therefore, the error amplifier varies the base current to Q<sub>1</sub>, which provides bias to Q<sub>2</sub> and Q<sub>3</sub>, based on the difference between the reference voltage and the scaled V<sub>LIN</sub> output voltage.

CONTROL FUNCTIONS

The watchdog timer circuitry monitors an input signal (WDI) from the microprocessor. It responds to the falling

edge of this watchdog signal which it expects to see within an externally programmable time (see Figure 7).

The watchdog time is given by:

$$t_{WDT} = 1.353 \times C_{Delay}R_{BIAS}$$

Using C<sub>Delay</sub> = 0.1 μF and R<sub>BIAS</sub> = 64.9 kΩ gives a time ranging from 6.25 ms to 11 ms assuming ideal components. Based on this, the software must be written so that the watchdog arrives at least every 6.25 ms. In practice, the tolerance of C<sub>Delay</sub> and R<sub>BIAS</sub> must be taken into account when calculating the minimum watchdog time (t<sub>WDT</sub>).

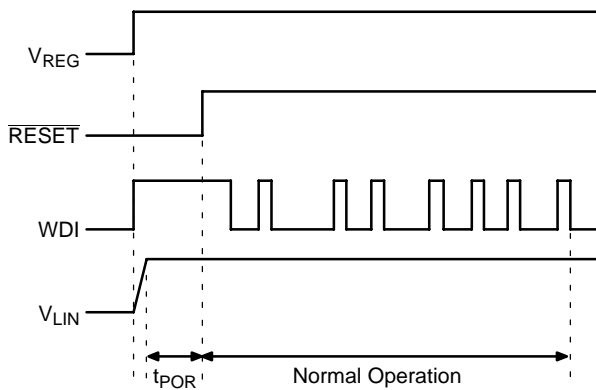
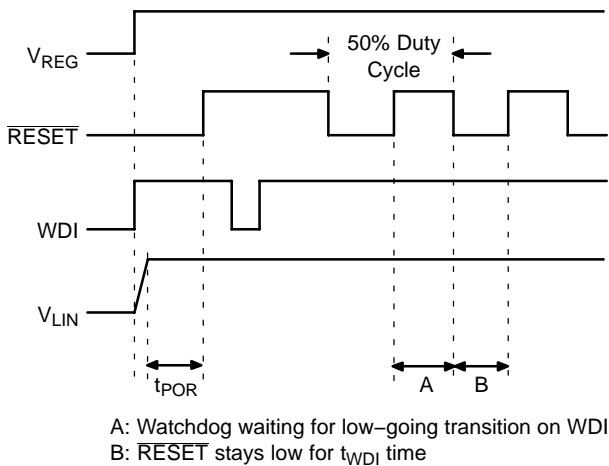

Figure 7. Timing Diagram for Normal Regulator Operation

If a correct watchdog signal is not received within the specified time a reset pulse train is issued until the correct watchdog signal is received. The nominal reset signal in this case is a 5 volt square wave with a 50% duty cycle as shown in Figure 8.

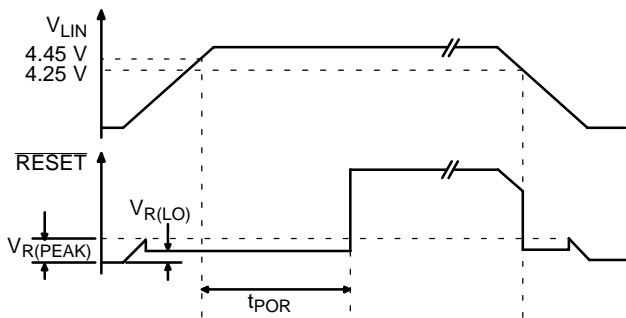

**Figure 8. Timing Diagram When WDI Fails to Appear Within the Preset Time Interval,  $t_{WDI}$**

The  $\overline{\text{RESET}}$  signal frequency is given by:

$$f_{\text{RESET}} = \frac{1}{2(t_{WDI})}$$

The Power On Reset (POR) and low voltage  $\overline{\text{RESET}}$  use the same circuitry and issue a reset when the linear output voltage is below the regulation limit. After  $V_{LIN}$  rises above the minimum specified value,  $\overline{\text{RESET}}$  remains low for a fixed period  $t_{POR}$  as shown in Figures 9 and 10.



**Figure 9. The Power On Reset Time Interval ( $t_{POR}$ ) Begins When  $V_{LIN}$  Rises Above 4.45 V (Typical)**

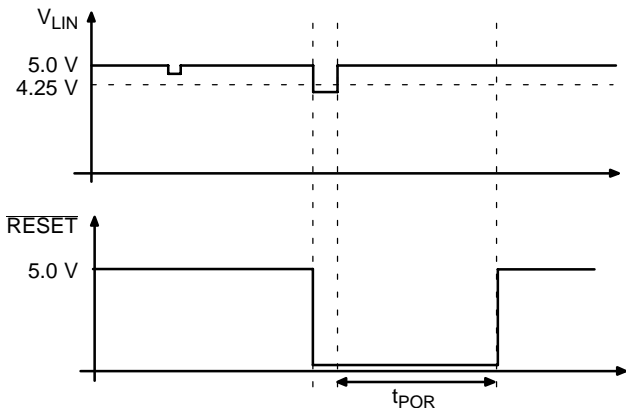

**Figure 10. RESET Signal Is Issued Whenever  $V_{LIN}$  Falls Below 4.25 V (Typical)**

The POR delay ( $t_{POR}$ ) is given by:

$$t_{POR} = 1.353 \times C_{\text{Delay}} R_{\text{BIAS}}$$

**CURRENT MODE PWM SWITCHING CIRCUITRY**

The current mode PWM switching voltage regulator contains an error amplifier with selectable feedback inputs, a current sense amplifier, an adjustable oscillator and a 1.4 A output power switch with antisaturation control. The switching regulator and external components, connected in a boost configuration, are shown in Figure 11.

The switching regulator begins operation when  $V_{REG}$  and  $V_{IN}$  are raised above 5.0 V.  $V_{REG}$  is required since the switching supply's control circuitry is powered through  $V_{LIN}$ .  $V_{IN}$  supplies the base drive to the switcher output transistor.

The output transistor turns on when the oscillator starts to charge the capacitor on  $C_{OSC}$ . The output current will develop a voltage drop across the internal sense resistor ( $R_S$ ). This voltage drop produces a proportional voltage at the output of the current sense amplifier, which is compared to the output of the error amplifier. The error amplifier generates an output voltage which is proportional to the difference between the scaled down output boost voltage ( $V_{FB1}$  or  $V_{FB2}$ ) and the internal bandgap voltage reference. Once the current sense amplifier output exceeds the error amplifier's output voltage, the output transistor is turned off.

The energy stored in the inductor during the output transistor on time is transferred to the load when the output transistor is turned off. The output transistor is turned back on at the next rising edge of the oscillator. On a cycle by cycle basis, the current mode controller in a discontinuous mode of operation charges the inductor to the appropriate amount of energy, based on the energy demand of the load. Figure 12 shows the typical current and voltage waveforms for a boost supply operating in the discontinuous mode.

**Notes:**

1. Refer to Figure 5 to determine oscillator frequency.
2. The switching regulator can be disabled by providing a logic high at the  $\overline{\text{ENABLE}}$  input.
3. The boost output voltage can be controlled dynamically by the feedback select input. If select is open,  $V_{FB2}$  is selected. If select is low, then  $V_{FB1}$  is selected.



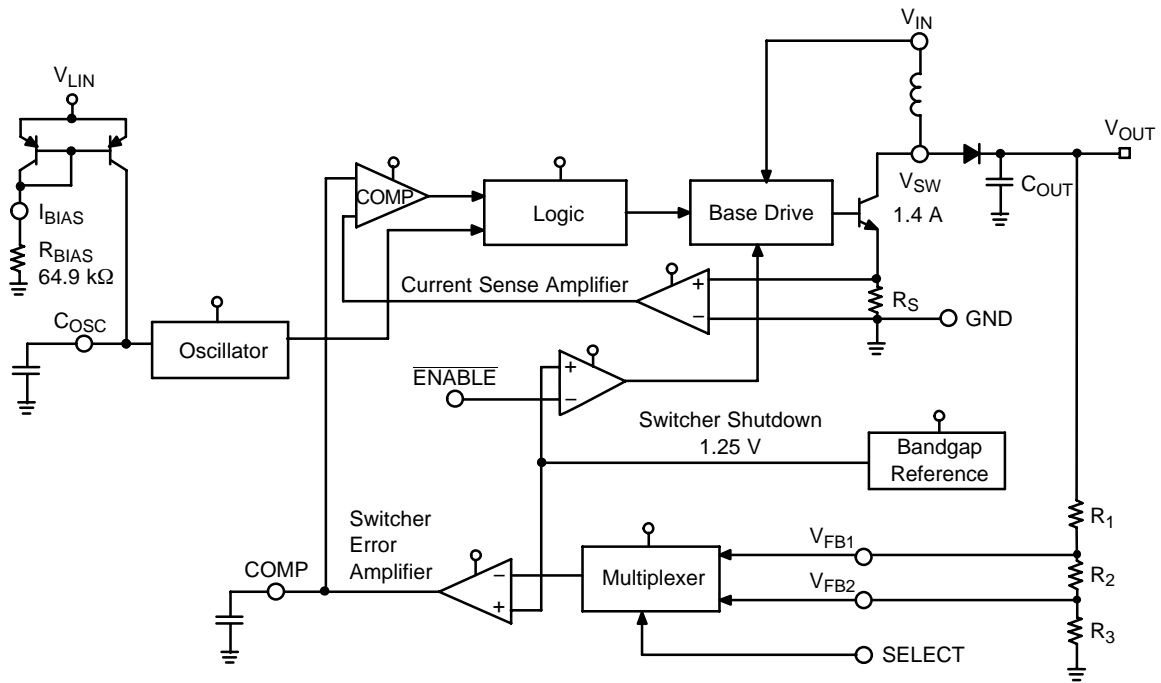

Figure 11. Block Diagram of the 1.4 A Current Mode Control Switching Regulator Portion of the CS5112 in a Boost Configuration

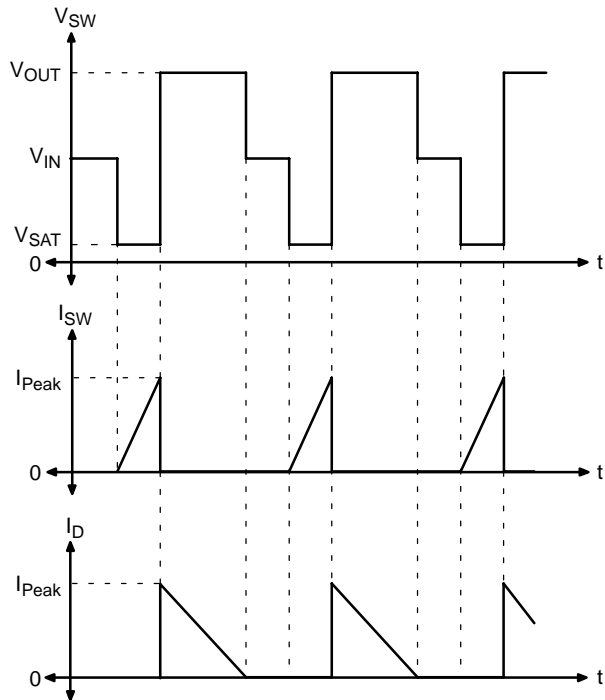

Figure 12. Voltage and Current Waveforms for Boost Topology in CS5112

**PROTECTION CIRCUITRY**

The current out of  $V_{LIN}$  is sensed in order to limit excessive power dissipation in the linear output transistor over the output range of 0 V to regulation. Also, the current into  $V_{SW}$  is sensed in order to provide the current limit function in the switcher output transistor.

If the die temperature is increased above 160°C, either due to excessive ambient temperature or excessive power dissipation, the drive to the linear output transistor is reduced proportionally with increasing die temperature. Therefore,  $V_{LIN}$  will decrease with increasing die temperature above 160°C. Since the switcher control circuitry is powered through  $V_{LIN}$ , the switcher performance, including current limit, will be affected by the decrease in  $V_{LIN}$ .

APPLICATION NOTES

**DESIGN PROCEDURE FOR BOOST TOPOLOGY**

This section outlines a procedure for designing a boost switching power supply operating in the discontinuous mode.

**Step 1**

Determine the output power required by the load.

$$P_{OUT} = I_{OUT}V_{OUT} \quad (1)$$

**Step 2**

Choose  $C_{OSC}$  based on the target oscillator frequency with an external resistor value,  $R_{BIAS} = 64.9 \text{ k}\Omega$ . (See Figure 5).

**Step 3**

Next select the output voltage feedback sense resistor divider as follows (Figure 13).

For  $V_{FB1}$  active, choose a value for  $R_1$  and then solve for  $R_{EQ}$  where:

$$R_{EQ} = \frac{R_1}{\frac{V_{OUT}}{V_{FB1}} - 1} \quad (2)$$

For  $V_{FB2}$  active, find:

$$V_{FB1} = V_{OUT} \left( \frac{R_{EQ}}{R_1 + R_{EQ}} \right) \quad (3)$$

and then calculate  $R_2$  where:

$$R_2 = \frac{V_{R2}}{I_{R2}} = \frac{V_{FB1} - V_{FB2}}{V_{FB1}/R_{EQ}} \quad (4)$$

Then find  $R_3$ , where:

$$R_3 = R_{EQ} - R_2 \quad (5)$$

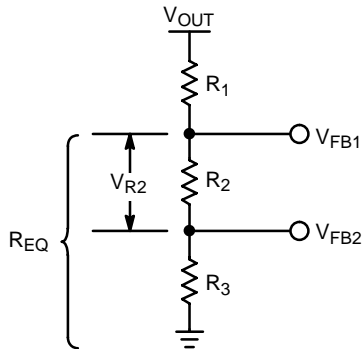

**Figure 13. Feedback Sense Resistor Divider Connected Between  $V_{OUT}$  and Ground**

**Step 4**

Determine the maximum on time at the minimum oscillator frequency and  $V_{IN}$ . For discontinuous operation, all of the stored energy in the inductor is transferred to the load prior to the next cycle. Since the current through the inductor cannot change instantaneously and the inductance is constant, a volt-second balance exists between the on time and off time. The voltage across the inductor during the on cycle is  $V_{IN}$  and the voltage across the inductor during the off cycle is  $V_{OUT} - V_{IN}$ .

Therefore:

$$V_{IN}t_{ON} = (V_{OUT} - V_{IN})t_{OFF} \quad (6)$$

where the maximum on time is:

$$t_{ON(MAX)} \approx \left[ 1 - \frac{V_{IN(MIN)}}{V_{OUT(MAX)}} \right] \left[ \frac{1}{f_{SW(MIN)}} \right] \quad (7)$$

**Step 5**

Calculate the maximum inductance allowed for discontinuous operation:

$$L_{(MAX)} = \frac{f_{SW(MIN)}V_{IN}^2(MIN)t_{ON}^2(MAX)}{2P_{OUT}/\eta} \quad (8)$$

where  $\eta$  = efficiency.

Usually  $\eta = 0.75$  is a good starting point. The IC's power dissipation should be calculated after the peak current has been determined in Step 6. If the efficiency is less than originally assumed, decrease the efficiency and recalculate the maximum inductance and peak current.

**Step 6**

Determine the peak inductor current at the minimum inductance, minimum  $V_{IN}$  and maximum on time to make sure the inductor current doesn't exceed 1.4 A.

$$I_{PK} = \frac{V_{IN(MIN)}t_{ON(MAX)}}{L(MIN)} \quad (9)$$

**Step 7**

Determine the minimum output capacitance and maximum ESR based on the allowable output voltage ripple.

$$C_{OUT(MIN)} = \frac{I_{PK}}{8f\Delta V_{RIPPLE}} \quad (10)$$

$$ESR(MIN) = \frac{\Delta V_{RIPPLE}}{I_{PK}} \quad (11)$$

In practice, it is normally necessary to use a larger capacitance value to obtain a low ESR. By placing capacitors in parallel, the equivalent ESR can be reduced.

**Step 8**

Compensate the feedback loop to guarantee stability under all operating conditions. To do this, we calculate the modulator gain and the feedback resistor network attenuation and set the gain of the error amplifier so that the overall loop gain is 0 dB at the crossover frequency,  $f_{CO}$ . In addition, the gain slope should be  $-20 \text{ dB/decade}$  at the crossover frequency.

The low frequency gain of the modulator (i.e. error amplifier output to output voltage) is:

$$\frac{\Delta V_{OUT}}{\Delta V_{EA}} = \frac{I_{PK(MAX)}}{V_{EA(MAX)}} \sqrt{\frac{R_{LOAD}L_f}{2}} \quad (12)$$

where:

$$I_{PK(MAX)} = \frac{V_{EA(MAX)}/G_{CSA}}{R_S} = \frac{2.4 \text{ V}/7}{150 \text{ m}\Omega} = 2.3 \text{ A} \quad (13)$$

The  $V_{OUT}/V_{EA}$  transfer function has a pole at:

$$f_p = 1/(\pi R_{LOAD} C_{OUT}) \quad (14)$$

and a zero due to the output capacitor's ESR at:

$$f_z = 1/(2\pi ESR(C_{OUT})) \quad (15)$$

Since the error amplifier reference voltage is 1.25 V, the output voltage must be divided down or attenuated before being applied to the input of the error amplifier. The feedback resistor divider attenuation is:

$$\frac{1.25 \text{ V}}{V_{OUT}}$$

The error amplifier in the CS5112 is an operational transconductance amplifier (OTA), with a gain given by:

$$G_{OTA} = g_m Z_{OUT} \quad (16)$$

where:

$$g_m = \frac{\Delta I_{OUT}}{\Delta V_{IN}} \quad (17)$$

For the CS5112,  $g_m = 2700 \mu\text{A/V}$  typical.

One possible error amplifier compensation scheme is shown in Figure 14. This gives the error amplifier a gain plot as shown in Figure 15.

For the error amplifier gain shown in Figure 15, a low frequency pole is generated by the error amplifier output impedance and  $C_1$ . This is shown by the line AB with a  $-20 \text{ dB/decade}$  slope in Figure 15. The slope changes to zero at point B due to the zero at:

$$f_z = 1/(2\pi R_4 C_1) \quad (18)$$

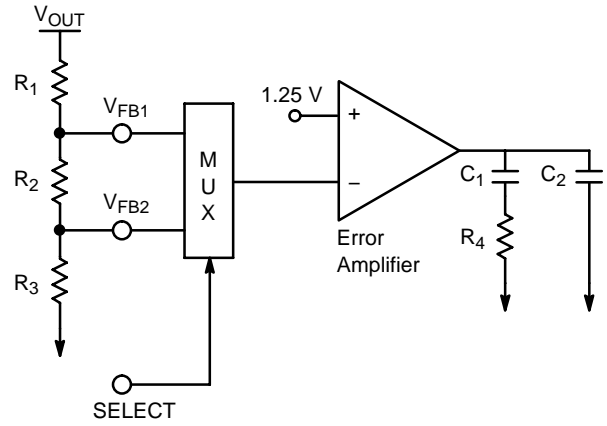

Figure 14. RC Network Used to Compensate the Error Amplifier (OTA)

A pole at point C:

$$f_p = 1/(\pi R_4 C_2) \quad (19)$$

offsets the zero set by the ESR of the output capacitors.

An alternative scheme uses a single capacitor as shown in Figure 16, to roll the gain off at a relatively low frequency.

**Step 9**

Finally the watchdog timer period and Power on Reset time is determined by:

$$t_{Delay} = 1.353 \times C_{Delay} R_{BIAS} \quad (20)$$

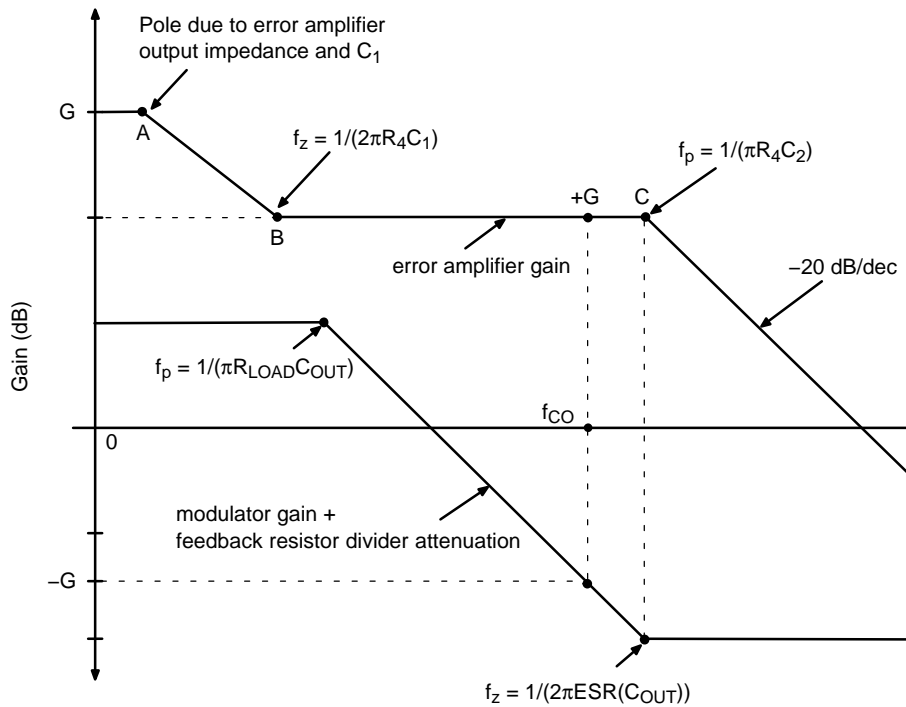

Figure 15. Bode Plot of Error Amplifier (OTA) Gain and Modulator Gain Added to the Feedback Resistor Divider Attenuation

# CS5112

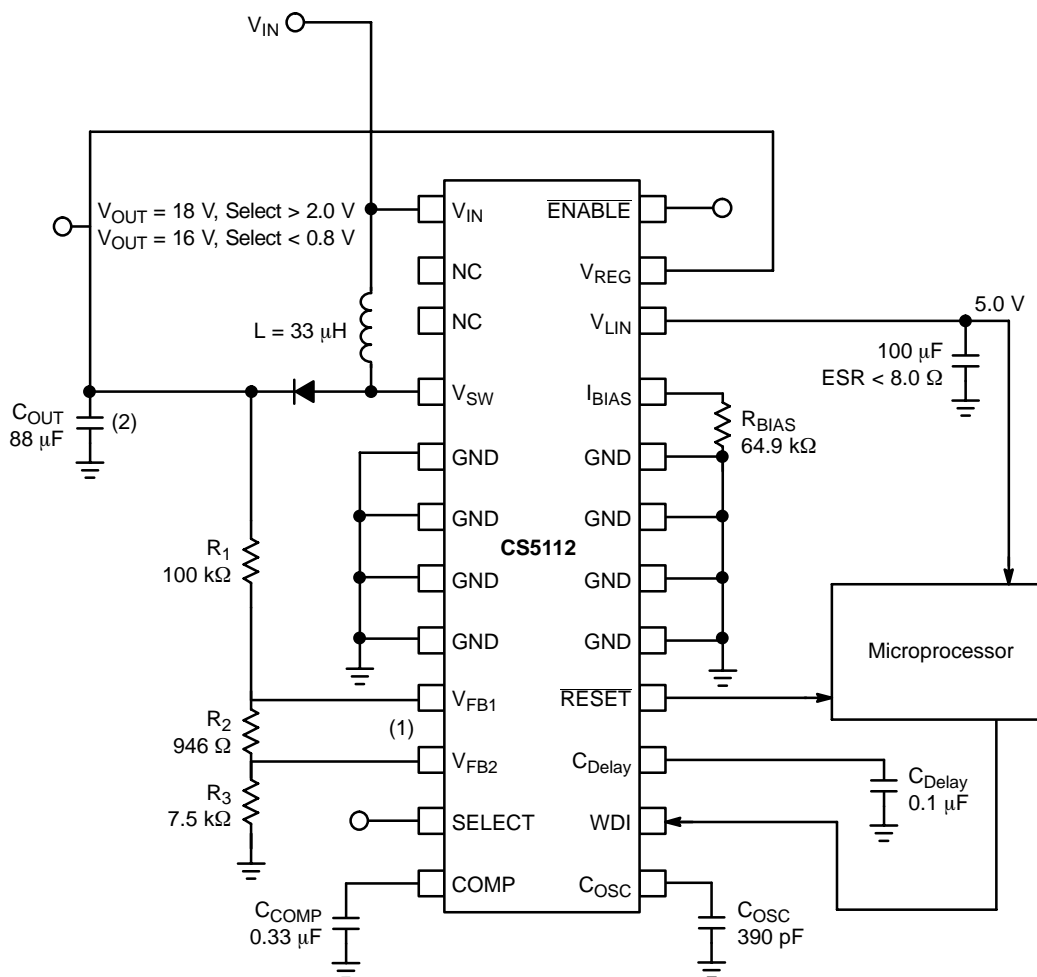

Figure 16. A Typical Application Diagram with External Components Configured in a Boost Topology

# CS5112

## LINEAR REGULATOR OUTPUT CURRENT VS. INPUT VOLTAGE

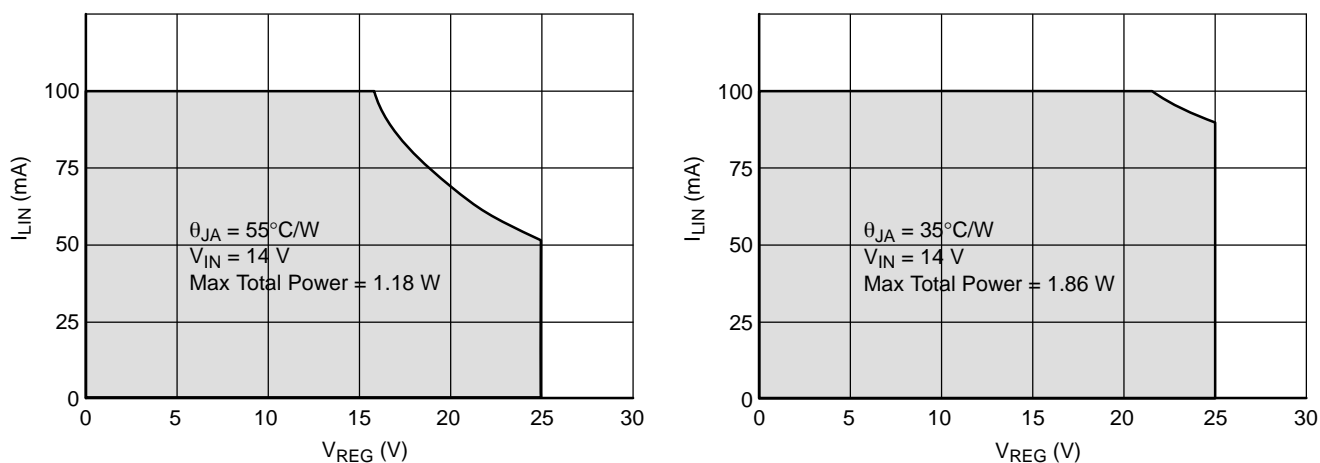

Figure 17. The Shaded Area Shows the Safe Operating Area of the CS5112 as a Function of  $I_{LIN}$ ,  $V_{REG}$ , and  $\theta_{JA}$ . Refer to Table 1 for Typical Loads and Voltages.

Table 1.

$V_{REG}$ (V)	$V_{IN}$ (V)	$I_{LIN}$ (mA)	Linear Power Dissipation (W)	Worst Case Switcher Power Available ( $\theta_{JA} = 55^{\circ}\text{C/W}$ ) (W)	Worst Case Switcher Power Available ( $\theta_{JA} = 35^{\circ}\text{C/W}$ ) (W)
20	14	25	0.44	0.74	1.42
20	14	50	0.83	0.35	1.03
20	14	75	1.22	*	0.64
20	14	100	1.60	*	0.26
25	14	25	0.60	0.58	1.26
25	14	50	1.11	0.07	0.75
25	14	75	1.62	*	0.24
25	14	100	2.14	*	*

\*Subjecting the CS5112 to these conditions will exceed the maximum total power that the part can handle, thereby forcing it into thermal limit.

# CS5112

## PACKAGE DIMENSIONS

SOIC-24  
DWF SUFFIX  
CASE 751E-04  
ISSUE E

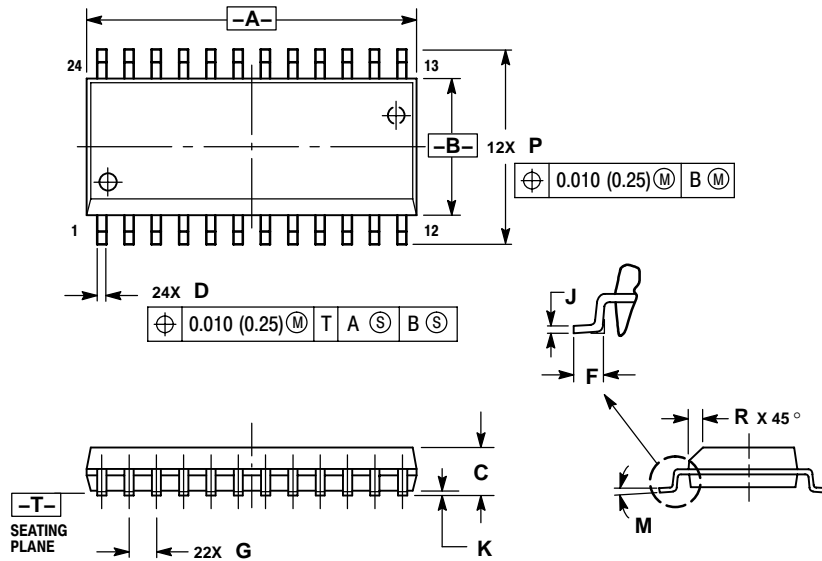

### NOTES:

1. DIMENSIONING AND TOLERANCING PER ANSI Y14.5M, 1982.
2. CONTROLLING DIMENSION: MILLIMETER.
3. DIMENSIONS A AND B DO NOT INCLUDE MOLD PROTRUSION.
4. MAXIMUM MOLD PROTRUSION 0.15 (0.006) PER SIDE.
5. DIMENSION D DOES NOT INCLUDE DAMBAR PROTRUSION. ALLOWABLE DAMBAR PROTRUSION SHALL BE 0.13 (0.005) TOTAL IN EXCESS OF D DIMENSION AT MAXIMUM MATERIAL CONDITION.

DIM	MILLIMETERS		INCHES	
	MIN	MAX	MIN	MAX
A	15.25	15.54	0.601	0.612
B	7.40	7.60	0.292	0.299
C	2.35	2.65	0.093	0.104
D	0.35	0.49	0.014	0.019
F	0.41	0.90	0.016	0.035
G	1.27 BSC		0.050 BSC	
J	0.23	0.32	0.009	0.013
K	0.13	0.29	0.005	0.011
M	0°	8°	0°	8°
P	10.05	10.55	0.395	0.415
R	0.25	0.75	0.010	0.029

### PACKAGE THERMAL DATA

Parameter		SOIC-24	Unit
R <sub>θJC</sub>	Typical	9	°C/W
R <sub>θJA</sub>	Typical	55	°C/W

ON Semiconductor and are registered trademarks of Semiconductor Components Industries, LLC (SCILLC). SCILLC reserves the right to make changes without further notice to any products herein. SCILLC makes no warranty, representation or guarantee regarding the suitability of its products for any particular purpose, nor does SCILLC assume any liability arising out of the application or use of any product or circuit, and specifically disclaims any and all liability, including without limitation special, consequential or incidental damages. "Typical" parameters which may be provided in SCILLC data sheets and/or specifications can and do vary in different applications and actual performance may vary over time. All operating parameters, including "Typicals" must be validated for each customer application by customer's technical experts. SCILLC does not convey any license under its patent rights nor the rights of others. SCILLC products are not designed, intended, or authorized for use as components in systems intended for surgical implant into the body, or other applications intended to support or sustain life, or for any other application in which the failure of the SCILLC product could create a situation where personal injury or death may occur. Should Buyer purchase or use SCILLC products for any such unintended or unauthorized application, Buyer shall indemnify and hold SCILLC and its officers, employees, subsidiaries, affiliates, and distributors harmless against all claims, costs, damages, and expenses, and reasonable attorney fees arising out of, directly or indirectly, any claim of personal injury or death associated with such unintended or unauthorized use, even if such claim alleges that SCILLC was negligent regarding the design or manufacture of the part. SCILLC is an Equal Opportunity/Affirmative Action Employer. This literature is subject to all applicable copyright laws and is not for resale in any manner.

### PUBLICATION ORDERING INFORMATION

**LITERATURE FULFILLMENT:**  
Literature Distribution Center for ON Semiconductor  
P.O. Box 61312, Phoenix, Arizona 85082-1312 USA  
**Phone:** 480-829-7710 or 800-344-3860 Toll Free USA/Canada  
**Fax:** 480-829-7709 or 800-344-3867 Toll Free USA/Canada  
**Email:** orderlit@onsemi.com

**N. American Technical Support:** 800-282-9855 Toll Free  
USA/Canada

**Japan:** ON Semiconductor, Japan Customer Focus Center  
2-9-1 Kamimeguro, Meguro-ku, Tokyo, Japan 153-0051  
**Phone:** 81-3-5773-3850

**ON Semiconductor Website:** <http://onsemi.com>

**Order Literature:** <http://www.onsemi.com/litorder>

For additional information, please contact your local Sales Representative.