

PANEL SIDE

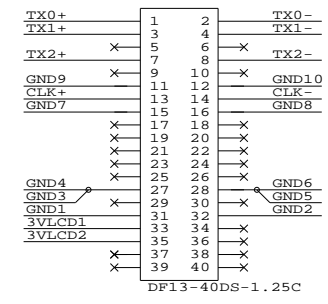

TOLERANCE:
+10mm
-10mm

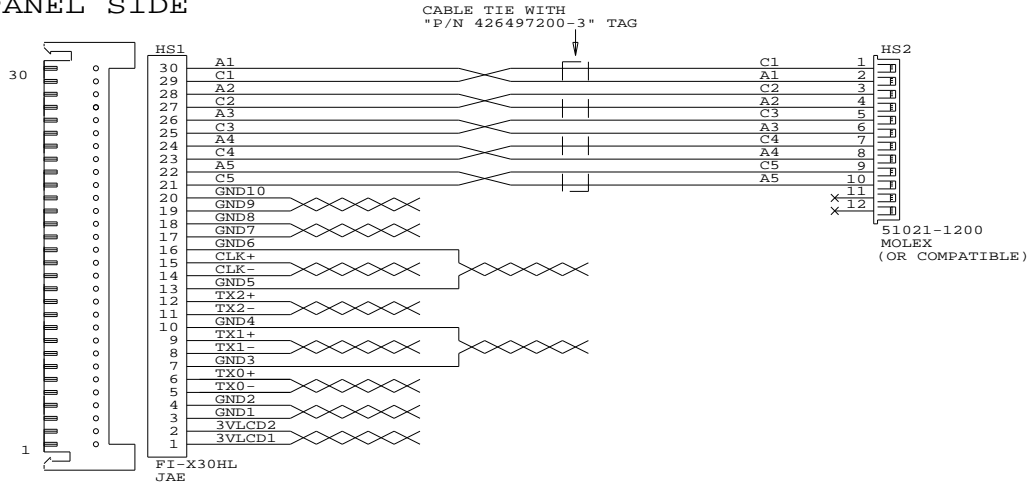
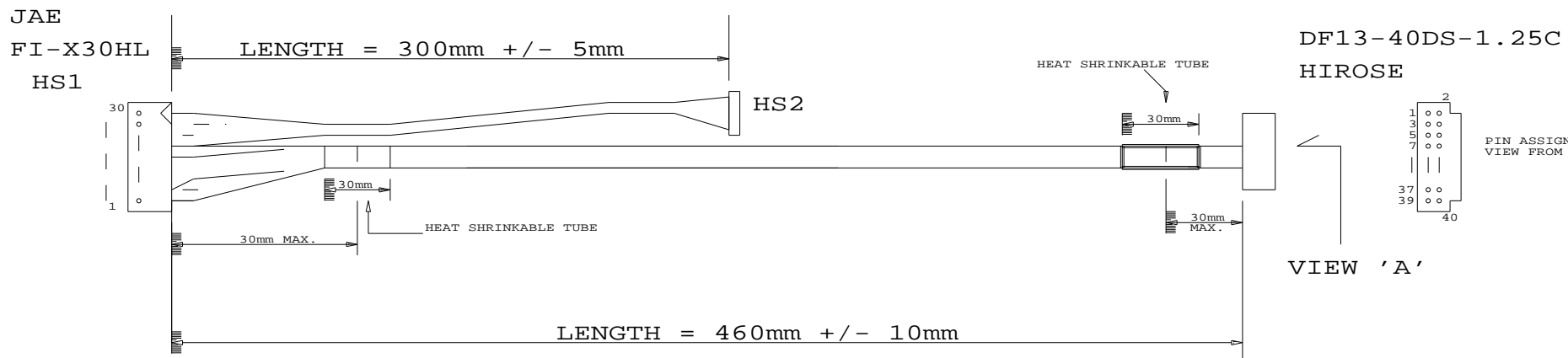

CABLE(HS1, PIN1-20) : UL 20276, 10 PAIRS, 30AWG, L=460mm JACKET: PVC COLOR BLACK
 CABLE(HS1, PIN21,23,25,27&29): UL 1061, 30AWG, BLACK
 CABLE(HS1, PIN22,24,26,28,30): UL 1061, 30AWG, RED

RoHS
COMPLIANCE

USAGE: FOR CONTROLLER SVH-1920, SP-1600 AND ALR-1400

P/N 426497200-3
 LVDS PANEL CABLE: NEC NL10276BC24-19D, 460mm

DIGITAL VIEW LTD. COPYRIGHT 2008, ALL RIGHTS RESERVED CONFIDENTIAL		
DRAWN BY: VICTOR NG		
Title LVDS CABLE: NEC NL10276BC24-19D, 460mm		
Size	Document Number	REV
B	(...\DV\DV_CABLE\C6497200.SCH)	00
Date:	June 4, 2008	Sheet 1 of 1