

Dual, Low Noise, High Performance Uncompensated Operational Amplifier

January 1989

Features

- This Circuit is Processed in Accordance to Mil-Std-883 and is Fully Conformant Under the Provisions of Paragraph 1.2.1.
- Low Input Noise Voltage Density @ 1kHz ... $6\text{nV}/\sqrt{\text{Hz}}$ Max
 $4.3\text{nV}/\sqrt{\text{Hz}}$ Typ
- High Slew Rate $12\text{V}/\mu\text{s}$ Min
 $20\text{V}/\mu\text{s}$ Typ
- Wide Gain Bandwidth Product ($A_{VCL} \geq 10$) .. 60MHz
- Low Offset Voltage Drift $3\mu\text{V}/^\circ\text{C}$ Typ
- High Open Loop Gain (Full Temp.) $100\text{kV}/\text{V}$ Min
 $250\text{kV}/\text{V}$ Typ
- High CMRR/PSRR (Full Temp.) 86dB Min
 100dB Typ
- Low Offset Voltage Drift $3\mu\text{V}/^\circ\text{C}$ Typ
- No Crossover Distortion
- Standard Dual Pinout

Applications

- High Quality Audio Preamplifiers
- High Q Active Filters
- Low Noise Function Generators
- Low Distortion Oscillators
- Low Noise Comparators

Description

Low noise and high performance are key words describing the dual, uncompensated HA-5112/883. This general purpose amplifier offers an array of dynamic specifications including $12\text{V}/\mu\text{s}$ slew rate (min), and 60MHz gain-bandwidth-product for $A_{VCL} \geq 10$. Complementing these outstanding parameters is a very low noise specification of $6\text{nV}/\sqrt{\text{Hz}}$ at 1kHz (max).

Fabricated using the Harris standard high frequency D.I. process, these operational amplifiers also offer excellent input specifications such as 2.5mV (max) offset voltage and 75nA (max) offset current. Complementing these specifications are 100dB (min) open loop gain and 100dB channel separation (typ). The HA-5112/883 also consumes a very modest amount of supply power ($180\text{mW}/\text{package}$).

This impressive combination of features make this amplifier ideally suited for designs ranging from audio amplifiers and active filters to the most demanding signal conditioning and instrumentation circuits.

This dual operational amplifier is available with industry standard pinouts allowing for immediate interchangeability with most other dual operational amplifiers. HA-5112/883 is available in an 8 pin Ceramic Mini-DIP, 20 pin LCC and an 8 pin Metal Can (TO-99).

Pinouts

HA7-5112/883 (CERAMIC MINI-DIP)
TOP VIEW

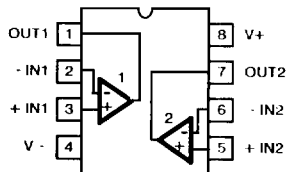

HA4-5112/883 (CERAMIC LCC)
TOP VIEW

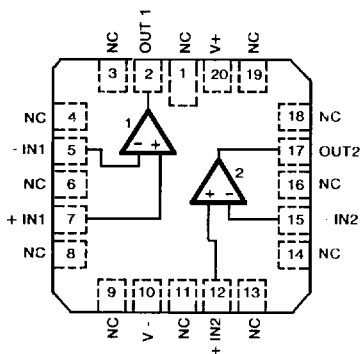

HA2-5112/883 (METAL CAN)
TOP VIEW

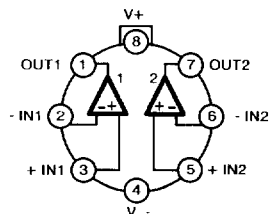

Specifications HA-5112/883

Absolute Maximum Ratings

Voltage Between V+ and V- Terminals	40V
Differential Input Voltage	7V
Voltage at Either Input Terminal	V+ to V-
Peak Output Current	Indefinite
(One Amplifier Shorted to Ground)	
Junction Temperature (T _J)	+175°C
Storage Temperature Range	-65°C to +150°C
ESD Rating	<2000V
Lead Temperature (Soldering 10 sec)	+275°C

CAUTION: Absolute maximum ratings are limiting values, applied individually beyond which the serviceability of the circuit may be impaired. Functional operability under any of these conditions is not necessarily implied.

Thermal Information

Thermal Resistance	θ_{ja}	θ_{jc}
Ceramic DIP Package	121°C/W	39°C/W
Ceramic LCC Package	74°C/W	20°C/W
Metal Can Package	101°C/W	30°C/W
Package Power Dissipation at +75°C for T _J ≤ +175°C		
Ceramic DIP Package		820mW
Ceramic LCC Package		1.36W
Metal Can Package		1W
Package Power Dissipation Derating Factor Above +75°C		
Ceramic DIP Package		8.2mW/°C
Ceramic LCC Package		13.6mW/°C
Metal Can Package		10mW/°C

Recommended Operating Conditions

Operating Temperature Range	-55°C to +125°C	V _{INcm} ≤ 1/2 (V+ - V-)
Operating Supply Voltage	±5V to ±15V	R _L ≥ 2kΩ

TABLE 1. D.C. ELECTRICAL PERFORMANCE CHARACTERISTICS

Device Tested at: Supply Voltage = ±15V, R_{SOURCE} = 100Ω, R_{LOAD} = 500kΩ, V_{OUT} = 0V, Unless Otherwise Specified.

D.C. PARAMETERS	SYMBOL	CONDITIONS	GROUP A SUBGROUP	TEMPERATURE	LIMITS		UNITS
					MIN	MAX	
Input Offset Voltage	V _{IO}	V _{CM} = 0V	1	+25°C	-2.0	2.0	mV
			2,3	+125°C, -55°C	-2.5	2.5	mV
Input Bias Current	+I _B	V _{CM} = 0V +R _S = 10kΩ -R _S = 100Ω	1	+25°C	-200	200	nA
			2,3	+125°C, -55°C	-325	325	nA
	-I _B	V _{CM} = 0V +R _S = 100Ω -R _S = 10kΩ	1	+25°C	-200	200	nA
			2,3	+125°C, -55°C	-325	325	nA
Input Offset Current	I _{IO}	V _{CM} = 0V +R _S = 10kΩ -R _S = 10kΩ	1	+25°C	-75	75	nA
			2,3	+125°C, -55°C	-125	125	nA
Common Mode Range	+CMR	V+ = 3V V- = -27V	1	+25°C	+12	-	V
			2,3	+125°C, -55°C	+12	-	V
	-CMR	V+ = 27V V- = -3V	1	+25°C	-	-12	V
			2,3	+125°C, -55°C	-	-12	V
Large Signal Voltage Gain	+A _{VOL}	V _{OUT} = 0V and +10V R _L = 2kΩ	4	+25°C	100	-	kV/V
			5,6	+125°C, -55°C	100	-	kV/V
	-A _{VOL}	V _{OUT} = 0V and -10V R _L = 2kΩ	4	+25°C	100	-	kV/V
			5,6	+125°C, -55°C	100	-	kV/V
Common Mode Rejection Ratio	+CMRR	ΔV _{CM} = +5V +V = +10V -V = -20V V _{OUT} = -5V	1	+25°C	86	-	dB
			2,3	+125°C, -55°C	86	-	dB
	-CMRR	ΔV _{CM} = -5V +V = +20V -V = -10V V _{OUT} = +5V	1	+25°C	86	-	dB
			2,3	+125°C, -55°C	86	-	dB

CAUTION: This device is sensitive to electrostatic discharge. Proper I.C. handling procedures should be followed.

TABLE 1. D.C. ELECTRICAL PERFORMANCE CHARACTERISTICS (Continued)

Device Tested at: Supply Voltage = $\pm 15V$, $R_{SOURCE} = 100\Omega$, $R_{LOAD} = 500k\Omega$, $V_{OUT} = 0V$, Unless Otherwise Specified.

D.C. PARAMETERS	SYMBOL	CONDITIONS	GROUP A SUBGROUP	TEMPERATURE	LIMITS		UNITS
					MIN	MAX	
Output Voltage Swing	+V _{OUT1}	R _L = 2k Ω	1	+25°C	10	-	V
			2, 3	+125°C, -55°C	10	-	V
	-V _{OUT1}	R _L = 2k Ω	1	+25°C	-	-10	V
			2, 3	+125°C, -55°C	-	-10	V
	+V _{OUT2}	R _L = 10k Ω	1	+25°C	12	-	V
			2, 3	+125°C, -55°C	12	-	V
-V _{OUT2}	R _L = 10k Ω	1	+25°C	-	-12	V	
		2, 3	+125°C, -55°C	-	-12	V	
Output Current	+I _{OUT}	V _{OUT} = -5V	1	+25°C	10	-	mA
			2, 3	+125°C, -55°C	10	-	mA
	-I _{OUT}	V _{OUT} = +5V	1	+25°C	-	-10	mA
			2, 3	+125°C, -55°C	-	-10	mA
Quiescent Power Supply Current	+I _{CC}	V _{OUT} = 0V I _{OUT} = 0mA	1	+25°C	-	5	mA
			2, 3	+125°C, -55°C	-	6	mA
	-I _{CC}	V _{OUT} = 0V I _{OUT} = 0mA	1	+25°C	-5	-	mA
			2, 3	+125°C, -55°C	-6	-	mA
Power Supply Rejection Ratio	+PSRR	$\Delta V_{SUP} = 10V$ +V = +10V, -V = -15V +V = +20V, -V = -15V	1	+25°C	86	-	dB
			2, 3	+125°C, -55°C	86	-	dB
	-PSRR	$\Delta V_{SUP} = 10V$ +V = +15V, -V = -10V +V = +15V, -V = -20V	1	+25°C	86	-	dB
			2, 3	+125°C, -55°C	86	-	dB

TABLE 2. A.C. ELECTRICAL PERFORMANCE CHARACTERISTICS

This Table Intentionally Left Blank. See A.C. Parameters on Table 3.

TABLE 3. ELECTRICAL PERFORMANCE CHARACTERISTICS

Device Characterized at: Supply Voltage = ±15V, R_{LOAD} = 2kΩ, C_{LOAD} = 50pF, A_{VCL} = 10V/V Unless Otherwise Specified.

PARAMETERS	SYMBOL	CONDITIONS	NOTES	TEMPERATURE	LIMITS		UNITS
					MIN	MAX	
Differential Input Resistance	R _{IN}	V _{CM} = 0V	1	+25°C	250	-	kΩ
Input Noise Voltage	E _n	R _S = 20Ω, f _o = 1000Hz	1	+25°C	-	6	nV/√Hz
Input Noise Current	I _n	R _S = 2MΩ, f _o = 1000Hz	1	+25°C	-	3	pA/√Hz
Gain Bandwidth Product	GBWP	V _O = 200mV, f _o = 10kHz	1	+25°C	40	-	MHz
		V _O = 200mV, f _o = 1MHz	1	+25°C	60	-	MHz
Slew Rate	+SR	V _{OUT} = -5V to +5V	1	+25°C	12	-	V/μs
	-SR	V _{OUT} = +5V to -5V	1	+25°C	12	-	V/μs
Full Power Bandwidth	FPBW	V _{PEAK} = 10V	1, 2	+25°C	191	-	kHz
Minimum Closed Loop Stable Gain	CLSG	R _L = 2kΩ, C _L = 50pF	1	-55°C to +125°C	10	-	V/V
Rise & Fall Time	T _R	V _{OUT} = 0V to +200mV	1, 4	+25°C	-	100	ns
	T _F	V _{OUT} = 0V to -200mV	1, 4	+25°C	-	100	ns
Overshoot	+OS	V _{OUT} = 0V to +200mV	1	+25°C	-	40	%
	-OS	V _{OUT} = 0V to -200mV	1	+25°C	-	40	%
Output Resistance	R _{OUT}	Open Loop	1	+25°C	-	150	Ω
Quiescent Power Consumption	PC	V _{OUT} = 0V, I _{OUT} = 0mA	1, 3	-55°C to +125°C	-	180	mW
Channel Separation	CS	R _S = 1kΩ, A _{VCL} = 100V/V, V _{IN} = 100mV _{RMS} @ 10kHz Referred to Input	1	+25°C	90	-	dB

- NOTES: 1. Parameters listed in Table 3 are controlled via design or process parameters and are not directly tested at final production. These parameters are lab characterized upon initial design release, or upon design changes. These parameters are guaranteed by characterization based upon data from multiple production runs which reflect lot to lot and within lot variation.
2. Full Power Bandwidth guarantee based on Slew Rate measurement using FPBW = Slew Rate/(2πV_{PEAK}).
3. Quiescent Power Consumption based upon Quiescent Supply Current test maximum. (No load on outputs.)
4. Measured between 10% and 90% points.

TABLE 4. ELECTRICAL TEST REQUIREMENTS

MIL-STD-883 TEST REQUIREMENTS	SUBGROUPS (SEE TABLES 1 & 2)
Interim Electrical Parameters (Pre Burn-in)	1
Final Electrical Test Parameters	1*, 2, 3, 4, 5, 6
Group A Test Requirements	1, 2, 3, 4, 5, 6
Groups C & D Endpoints	1

* PDA applies to Subgroup 1 only.

Test Circuit (Applies To Table 1)

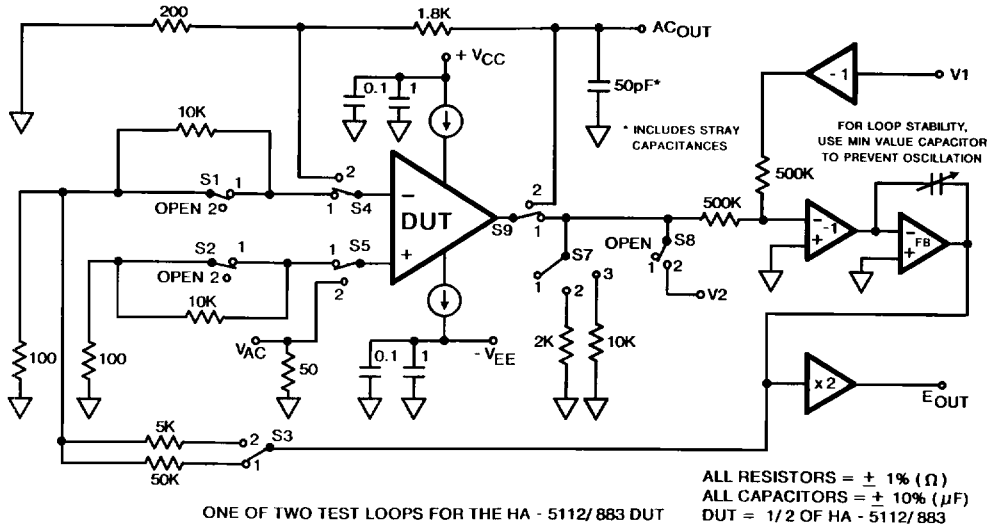

Test Waveforms

SIMPLIFIED TEST CIRCUIT (Applies To Table 3)

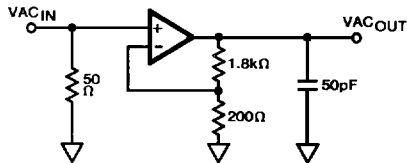

SLEW RATE WAVEFORM

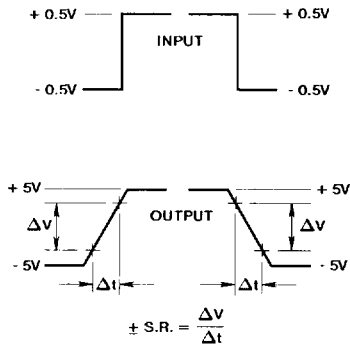

TRANSIENT RESPONSE WAVEFORM

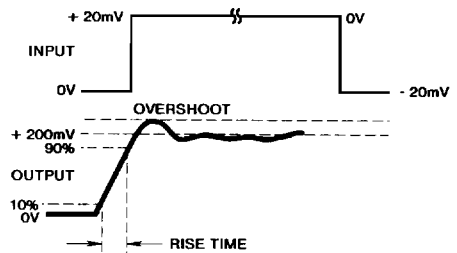

NOTE: Measured on both positive and negative transitions.

Burn-In Circuits

HA7-5112/883 CERAMIC DIP

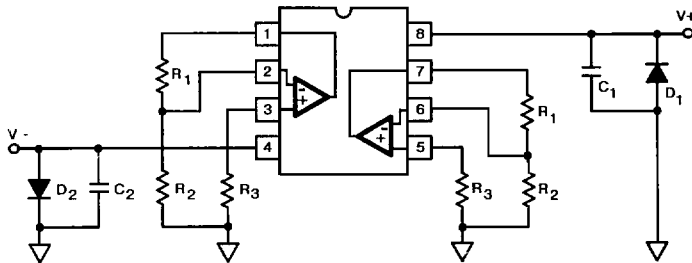

HA4-5112/883 CERAMIC LCC

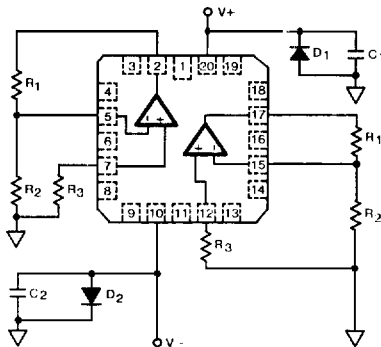

HA2-5112/883 (TO-99) METAL CAN

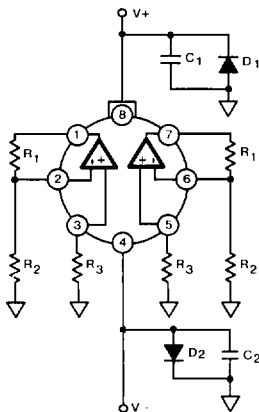

NOTES:

- R₁ = 10kΩ, ±5%, 1/4W (Min)
- R₂ = R₃ = 1kΩ, ±5%, 1/4W (Min)
- C₁ = C₂ = 0.01μF/Socket (Min) or 0.1μF/Row, (Min)
- D₁ = D₂ = 1N4002 or Equivalent/Board
- |V₊ - V₋| = 30V

Schematic Diagram (1/2 HA-5112/883)

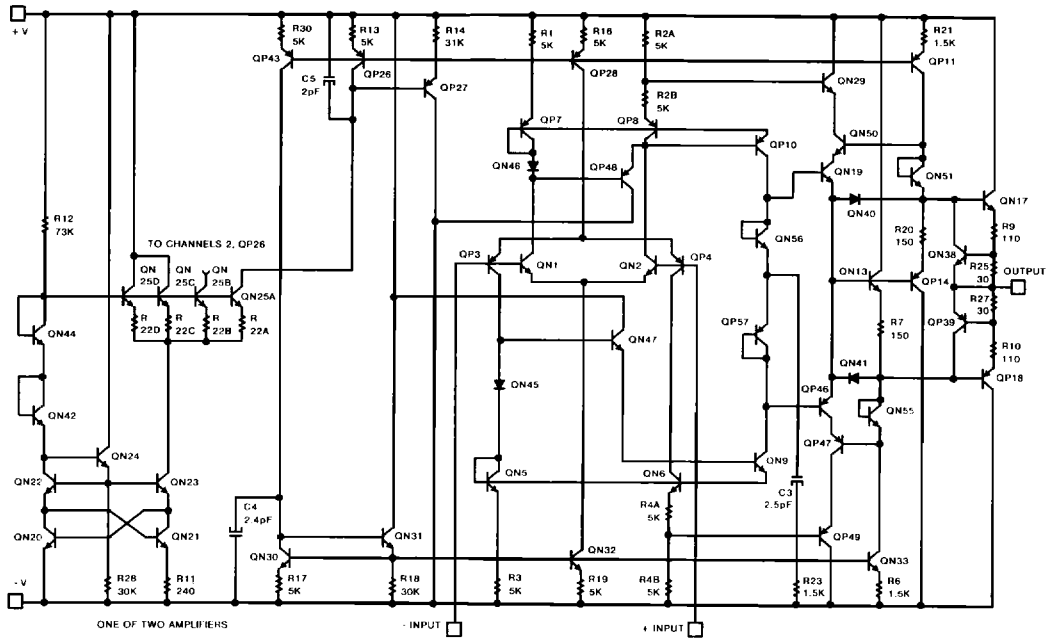

Die Characteristics

DIE DIMENSIONS:

98.4 x 67.3 x 19 mils
(2500 x 1710 x 483 μm)

METALLIZATION:

Type: Aluminum
Thickness: 16kÅ ± 2kÅ

WORST CASE CURRENT DENSITY:

1.43 x 10⁵A/cm² at 10mA

SUBSTRATE POTENTIAL (POWERED UP):

Unbiased

GLASSIVATION:

Type: Nitride
Thickness: 7kÅ ± 0.7kÅ

TRANSISTOR COUNT: 93

PROCESS: HFSB Linear Dielectric Isolation

DIE ATTACH:

Material: Gold/Silicon Eutectic Alloy
Temperature: Ceramic DIP — 460°C (Max)
Ceramic LCC — 420°C (Max)
Metal Can — 420°C (Max)

Metallization Mask Layout

HA-5112/883

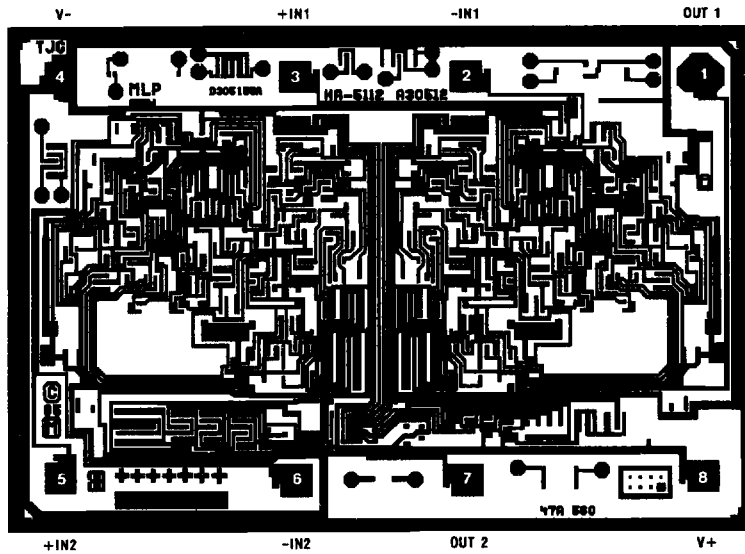

NOTE: Pin Numbers Correspond to Mini-DIP and Metal Can Packages Only.

3
OP AMPS &
COMPARATORS

DESIGN INFORMATION

Dual, Low Noise, High Performance Uncompensated Operational Amplifier

The information contained in this section has been developed through characterization by Harris Semiconductor and is for use as application and design aid only. These characteristics are not 100% tested and no product guarantee is implied.

Typical Performance Curves Unless Otherwise Specified: $T_A = +25^\circ\text{C}$, $V_{\text{SUPPLY}} = \pm 15\text{V}$

INPUT NOISE VOLTAGE DENSITY
 $V_{\text{CC}} = \pm 15\text{V}$, $T_A = +25^\circ\text{C}$

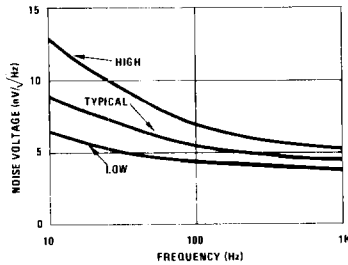

0.1Hz TO 10Hz NOISE
 $V_{\text{CC}} = \pm 15\text{V}$, $T_A = +25^\circ\text{C}$
 $50\mu\text{V}/\text{Div.}$, $1\text{s}/\text{Div.}$, $A_V = 1000\text{V}/\text{V}$
Input Noise = $0.232\mu\text{V}_{\text{p-p}}$

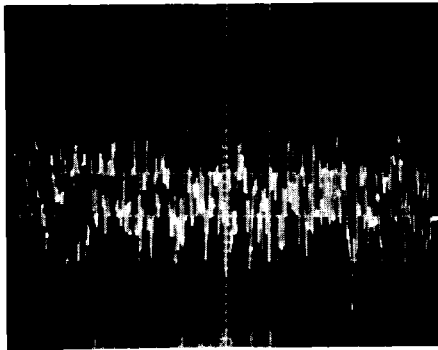

V_{IO} vs. TEMPERATURE
 $V_{\text{CC}} = \pm 15\text{V}$

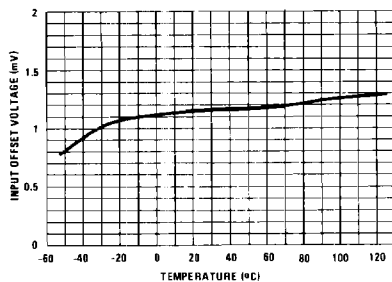

INPUT NOISE CURRENT DENSITY
 $V_{\text{CC}} = \pm 15\text{V}$, $T_A = +25^\circ\text{C}$

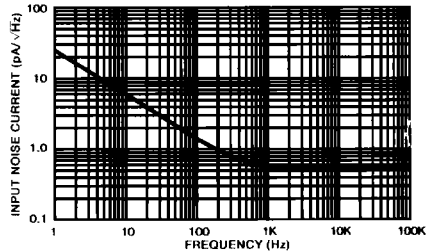

0.1Hz TO 1MHz NOISE
 $V_{\text{CC}} = \pm 15\text{V}$, $T_A = +25^\circ\text{C}$
 $500\mu\text{V}/\text{Div.}$, $1\text{s}/\text{Div.}$, $A_V = 1000\text{V}/\text{V}$
Total Output Noise = $2.075\mu\text{V}_{\text{p-p}}$

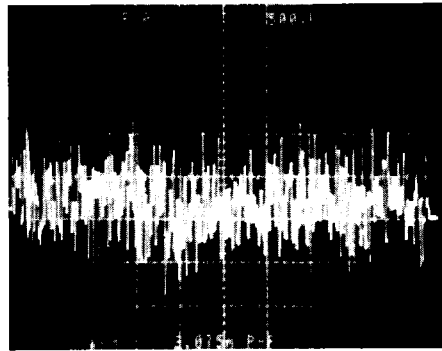

I_{IO} vs. TEMPERATURE
 $V_{\text{CC}} = \pm 15\text{V}$

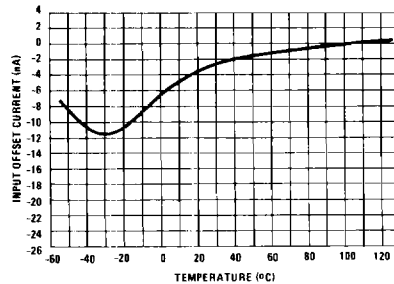

DESIGN INFORMATION (Continued)

The information contained in this section has been developed through characterization by Harris Semiconductor and is for use as application and design aid only. These characteristics are not 100% tested and no product guarantee is implied.

Typical Performance Curves Unless Otherwise Specified: $T_A = +25^\circ\text{C}$, $V_{\text{SUPPLY}} = \pm 15\text{V}$

V_{IO} vs. V_{CC}
 $T_A = +25^\circ\text{C}$

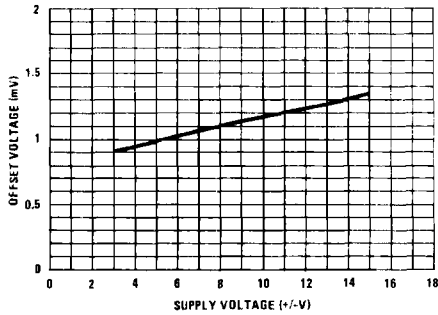

I_{BIAS} vs. TEMPERATURE
 $V_{\text{CC}} = \pm 15\text{V}$

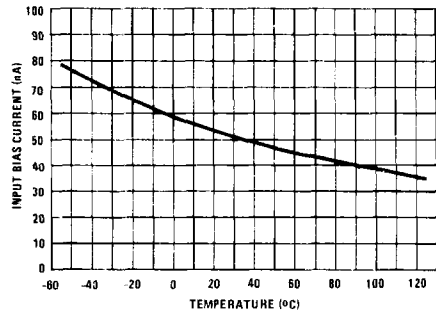

A_{VOL} vs. TEMPERATURE
 $V_{\text{CC}} = \pm 15\text{V}$, $\Delta V_{\text{O}} = \pm 10\text{V}$, $R_{\text{L}} = 2\text{K}$

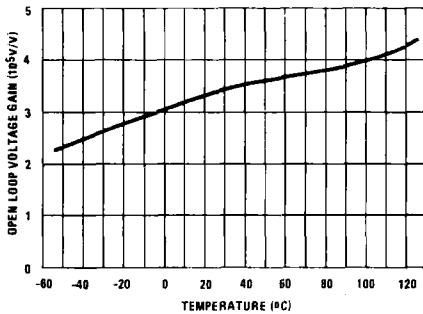

A_{VOL} vs. LOAD RESISTANCE
 $V_{\text{O}} = \pm 10\text{V}$, $V_{\text{CC}} = \pm 15\text{V}$, $T_A = +25^\circ\text{C}$

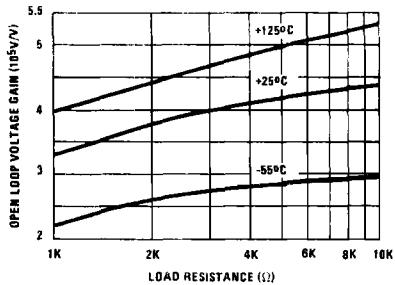

A_{VOL} vs. V_{CC}
 $T_A = +25^\circ\text{C}$, $R_{\text{L}} = 2\text{K}$

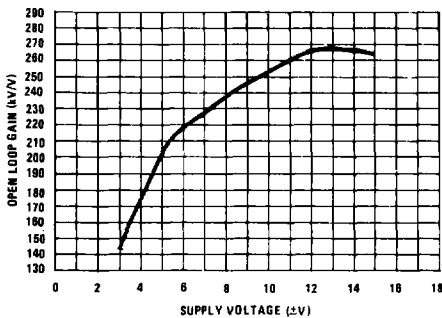

V_{OUT} vs. V_{CC}
 $T_A = +25^\circ\text{C}$, $R_{\text{L}} = 2\text{K}$

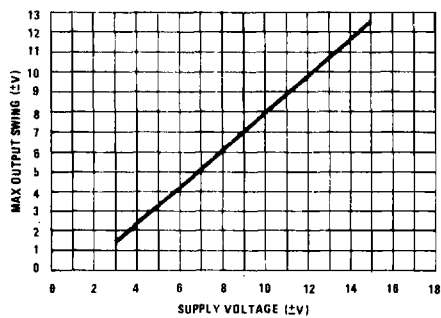

DESIGN INFORMATION (Continued)

The information contained in this section has been developed through characterization by Harris Semiconductor and is for use as application and design aid only. These characteristics are not 100% tested and no product guarantee is implied.

Typical Performance Curves Unless Otherwise Specified: $T_A = +25^\circ\text{C}$, $V_{\text{SUPPLY}} = \pm 15\text{V}$

OUTPUT SHORT-CIRCUIT CURRENT vs. TIME
 $V_{\text{CC}} = \pm 15\text{V}$, $T_A = +25^\circ\text{C}$

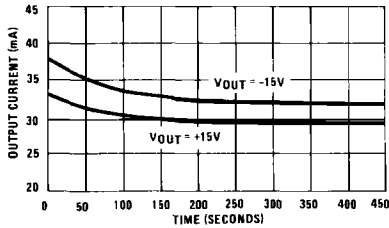

CMRR vs. FREQUENCY

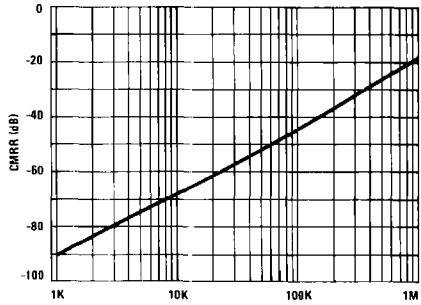

PSRR vs. FREQUENCY

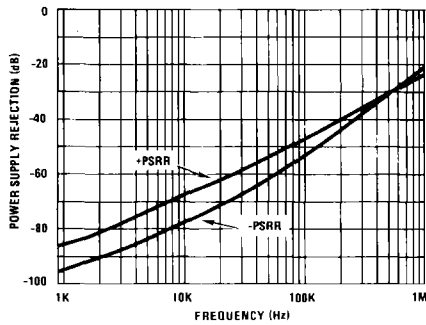

CHANNEL SEPARATION vs. FREQUENCY
 $10\text{Hz} \leq f \leq 10\text{MHz}$

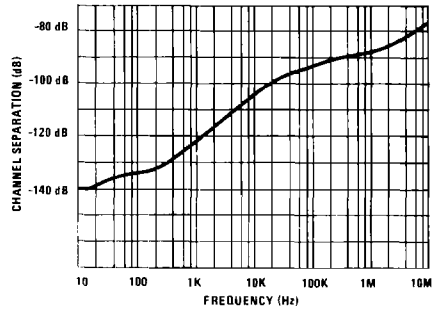

HA-5112 FREQUENCY RESPONSE
 $A_{\text{VCL}} = 10$, $T_A = +25^\circ\text{C}$, $R_L = 2\text{K}$, $C_L = 50\text{pF}$

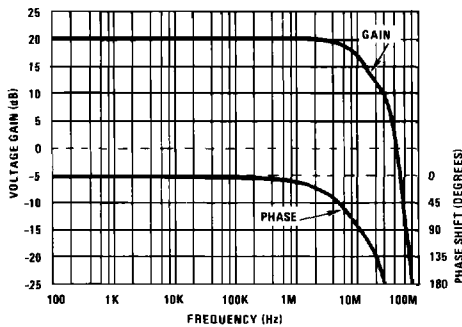

OPEN-LOOP GAIN vs. FREQUENCY
 $V_{\text{CC}} = \pm 15\text{V}$, $R_L = 2\text{K}$, $C_L = 50\text{pF}$, $T_A = +25^\circ\text{C}$

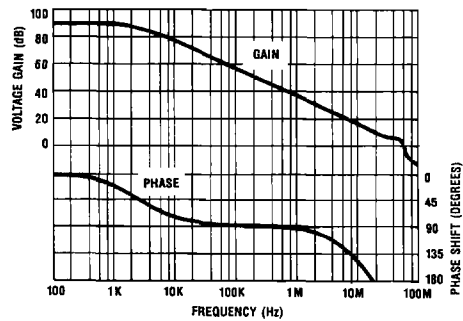

DESIGN INFORMATION (Continued)

The information contained in this section has been developed through characterization by Harris Semiconductor and is for use as application and design aid only. These characteristics are not 100% tested and no product guarantee is implied.

Typical Performance Curves Unless Otherwise Specified: $T_A = +25^\circ\text{C}$, $V_{\text{SUPPLY}} = \pm 15\text{V}$

SLEW RATE vs. TEMPERATURE
 $R_L = 2\text{K}$, $C_L = 50\text{pF}$, $V_{\text{CC}} = \pm 15\text{V}$

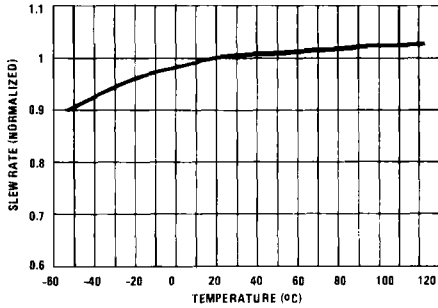

RISE TIME vs. TEMPERATURE
 $R_L = 2\text{K}$, $C_L = 50\text{pF}$, $V_{\text{CC}} = \pm 15\text{V}$

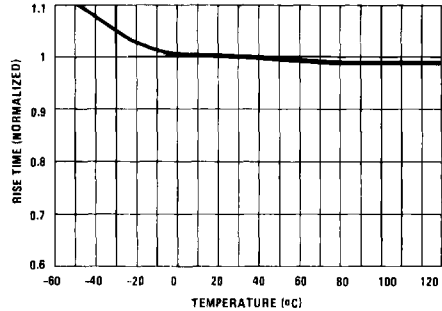

SMALL SIGNAL OVERSHOOT vs. C_{LOAD}
 $R_L = 2\text{K}$, $T_A = +25^\circ\text{C}$, $V_{\text{CC}} = \pm 15\text{V}$

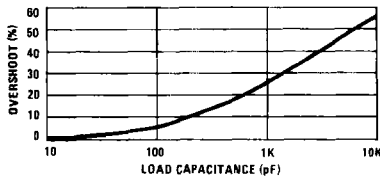

I_{CC} vs. V_{CC}
 $T_A = +25^\circ\text{C}$, $I_{\text{OUT}} = 0\text{mA}$

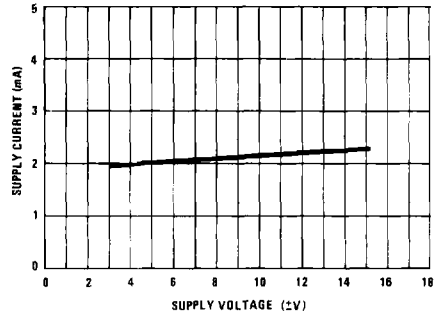

LARGE SIGNAL RESPONSE

$V_{\text{OUT}} = \pm 3\text{V}$, $A_V = 10$, $R_L = 2\text{K}$, $C_L = 50\text{pF}$
 Input = 500mV/Div., Output = 2V/Div., Timescale = 200ns/Div.

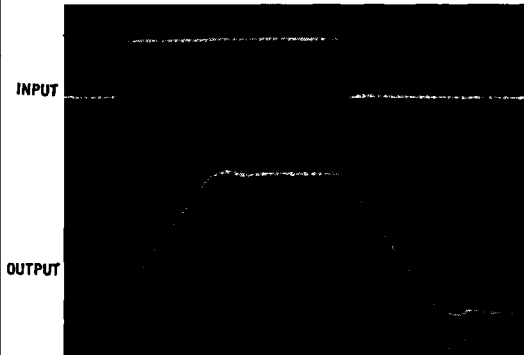

SMALL SIGNAL RESPONSE

$V_{\text{OUT}} = 0\text{V}$ to -200mV for Fall Time & -Overshoot
 $A_V = 10$, $R_L = 2\text{K}$, $C_L = 50\text{pF}$, Timescale = 50ns/Div.



DESIGN INFORMATION (Continued)

The information contained in this section has been developed through characterization by Harris Semiconductor and is for use as application and design aid only. These characteristics are not 100% tested and no product guarantee is implied.

TYPICAL PERFORMANCE CHARACTERISTICS

Device Characterized at: Supply Voltage = $\pm 15V$, $R_L = 2k\Omega$, $C_L = 50pF$, $A_{VCL} = 10V/V$ Unless Otherwise Specified.

PARAMETERS	CONDITIONS	TEMP	TYPICAL	DESIGN LIMITS	UNITS
Offset Voltage	$V_{CM} = 0V$	+25°C	0.8	Table 1	mV
Offset Voltage Average Drift	Versus Temperature	-55°C to +125°C	3	7	$\mu V/^\circ C$
Offset Current Average Drift	Versus Temperature	-55°C to +125°C	100	250	$pA/^\circ C$
Input Bias Current	$V_{CM} = 0V$	+25°C	50	Table 1	nA
Input Offset Current	$V_{CM} = 0V$	+25°C	25	Table 1	nA
Differential Input Resistance	$V_{CM} = 0V$	+25°C	500	Table 3	$k\Omega$
Input Noise Voltage Density	$f_o = 10Hz$	+25°C	10.3	14	nV/\sqrt{Hz}
	$f_o = 100Hz$	+25°C	5.6	8	nV/\sqrt{Hz}
	$f_o = 1kHz$	+25°C	4.3	Table 3	nV/\sqrt{Hz}
Input Noise Current Density	$f_o = 10Hz$	+25°C	6	15	pA/\sqrt{Hz}
	$f_o = 100Hz$	+25°C	1.5	5	pA/\sqrt{Hz}
	$f_o = 1kHz$	+25°C	0.52	Table 3	pA/\sqrt{Hz}
Large Signal Voltage Gain	$V_{OUT} = \pm 10V$	-55°C	200	Table 1	kV/V
		+25°C	300	Table 1	kV/V
		+125°C	400	Table 1	kV/V
Slew Rate	$V_{OUT} = \pm 5V$	-55°C to +125°C	± 20	± 10	$V/\mu s$
Full Power Bandwidth	Note 2, $V_{peak} = 10V$	-55°C to +125°C	318	159	kHz
Rise and Fall Times	$V_{OUT} = \pm 200mV$	-55°C to +125°C	48	130	ns
Overshoot	$V_{OUT} = \pm 200mV$	-55°C to +125°C	30	50	%
Settling Time	To 0.1% for 10V Step	+25°C	0.6	1	μs
	To 0.01% for 10V Step	+25°C	1.2	2	μs
Output Short Circuit Current	To <10 Seconds, $V_{OUT} = \pm 15V$	+25°C	± 35	± 50	mA
Output Resistance	Open Loop	+25°C	110	Table 3	Ω
Channel Separation	$f = 10kHz$	+25°C	108	Table 3	dB
Supply Current	No Load	+25°C	2.4	Table 1	mA
Minimum Supply Voltage	Functional Operation Only, Other Parameters Will Vary	+25°C	± 4	± 5	V