

LOC	DIST	REVISIONS			
DF	AO	REV	DATE	BY	APPV
A		REVISED PER ECO-13-002047	05FEB2013	MGM	CT

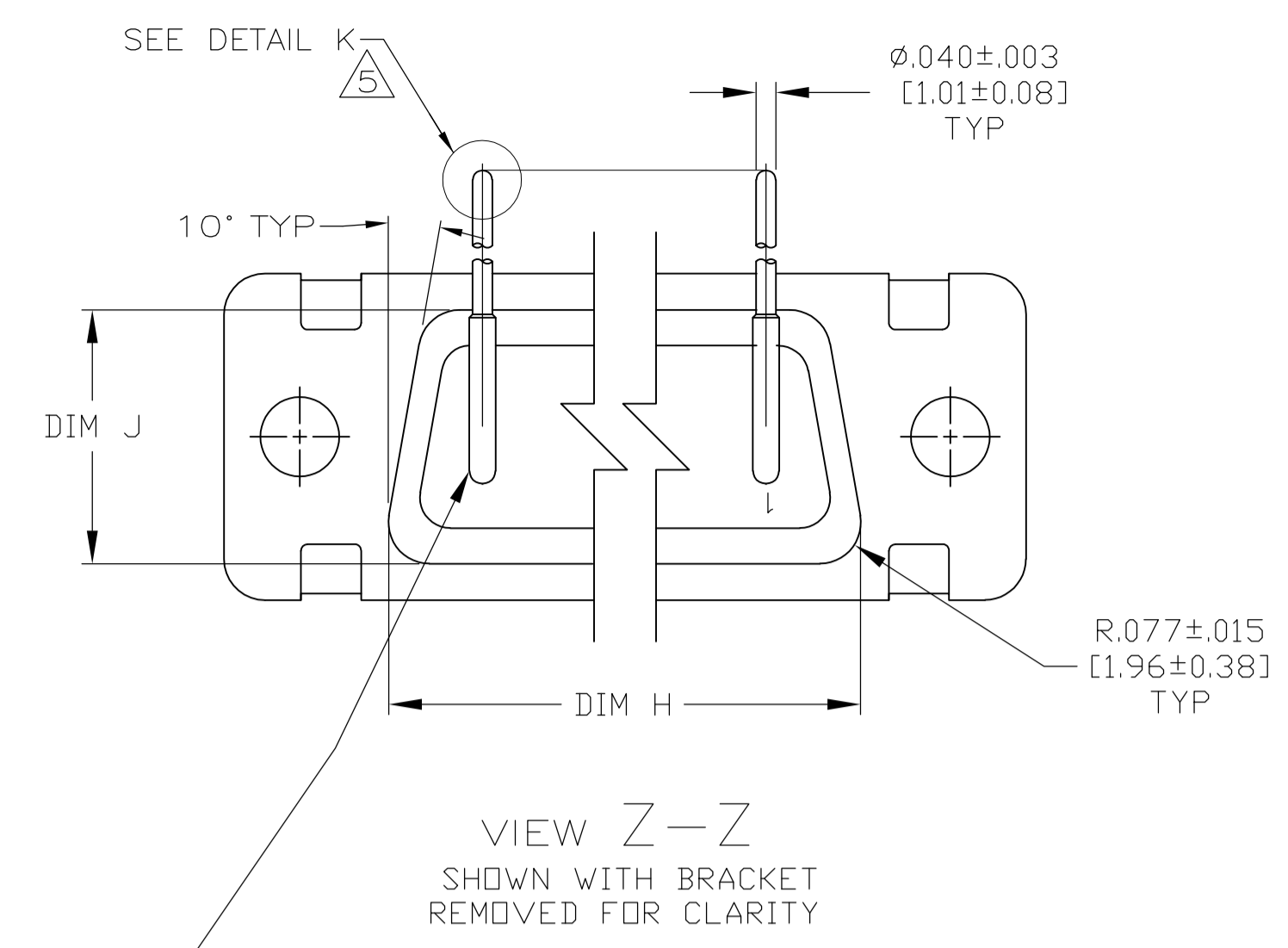

CONTACT (QTY = NO. OF POSN)  
MATL: BRASS PER ASTM-B-16, OR BERYLLIUM COPPER PER ASTM-B-194  
FINISH: GOLD PER ASTM-B-488, TYPE II, GRADE C, CLASS 1.27 IN CONTACT MATING AREA, .000010 [0.0003] MIN THK GOLD PER ASTM-B-488 OVER .000050 [0.0013] MIN THK NICKEL PER SAE-AMS-QQ-N-290 ON CONTACT BODY

- SEE SHEET 2 FOR RECOMMENDED P.C. BOARD LAYOUT. TRUE POSITION TOLERANCE FOR P.C. BOARD LAYOUT IS .010 [0.25] AT MAX MATERIAL CONDITION. SUGGESTED BOARD THICKNESS IS .062 [1.57]
- THE CONNECTORS DESCRIBED IN THIS DOCUMENT MEET THE REQUIREMENTS OF MIL-C-24308 AND MATE WITH ANY PLUG CONNECTOR WITH SAME INSERT ARRANGEMENT.
- MARKED WITH .047 [1.19]-.062 [1.57] HIGH CHARACTERS. FAR SIDE REFERS TO THE WIDE SIDE OF THE KEYSTONE. NEAR SIDE REFERS TO THE NARROW SIDE OF THE KEYSTONE. IF THE REAR SHELL IS TOO SMALL FOR THE ENTIRE MILITARY PART NUMBER, MARKING SHALL BE LOCATED AS FOLLOWS:  
A. "M24308" ON FRONT SHELL, FAR SIDE.  
B. SLASH SHEET AND DASH NUMBER ON REAR SHELL, FAR SIDE.  
C. "TYCO" AND DATE CODE ON FRONT SHELL, NEAR SIDE.  
D. TYCO PART NUMBER ON REAR SHELL, NEAR SIDE.  
IF THE FRONT SHELL IS TOO SMALL FOR "TYCO", TYCO PART NUMBER AND DATE CODE, MARKING SHALL BE SPLIT AS FOLLOWS:  
A. TYCO PART NUMBER ON REAR SHELL, NEAR SIDE.  
B. "TYCO" AND DATE CODE ON FRONT SHELL, NEAR SIDE.  
C. MILITARY PART NUMBER ON REAR SHELL, FAR SIDE.
- POINT OF ELECTRICAL ENGAGEMENT - AS MEASURED WITH A .0390-.0393 [0.991-0.998] DIA SQUARE ENDED PIN.
- SOLDER DIPPED PER J-STD-001 WITH Sn63 SOLDER PER J-STD-006 IN THE ENTIRE AREA OF DIMENSION SHOWN. (1757844-6 THRU -10 ONLY.)
- MEETS SOLDERABILITY PER MIL-STD-202 METHOD 208.

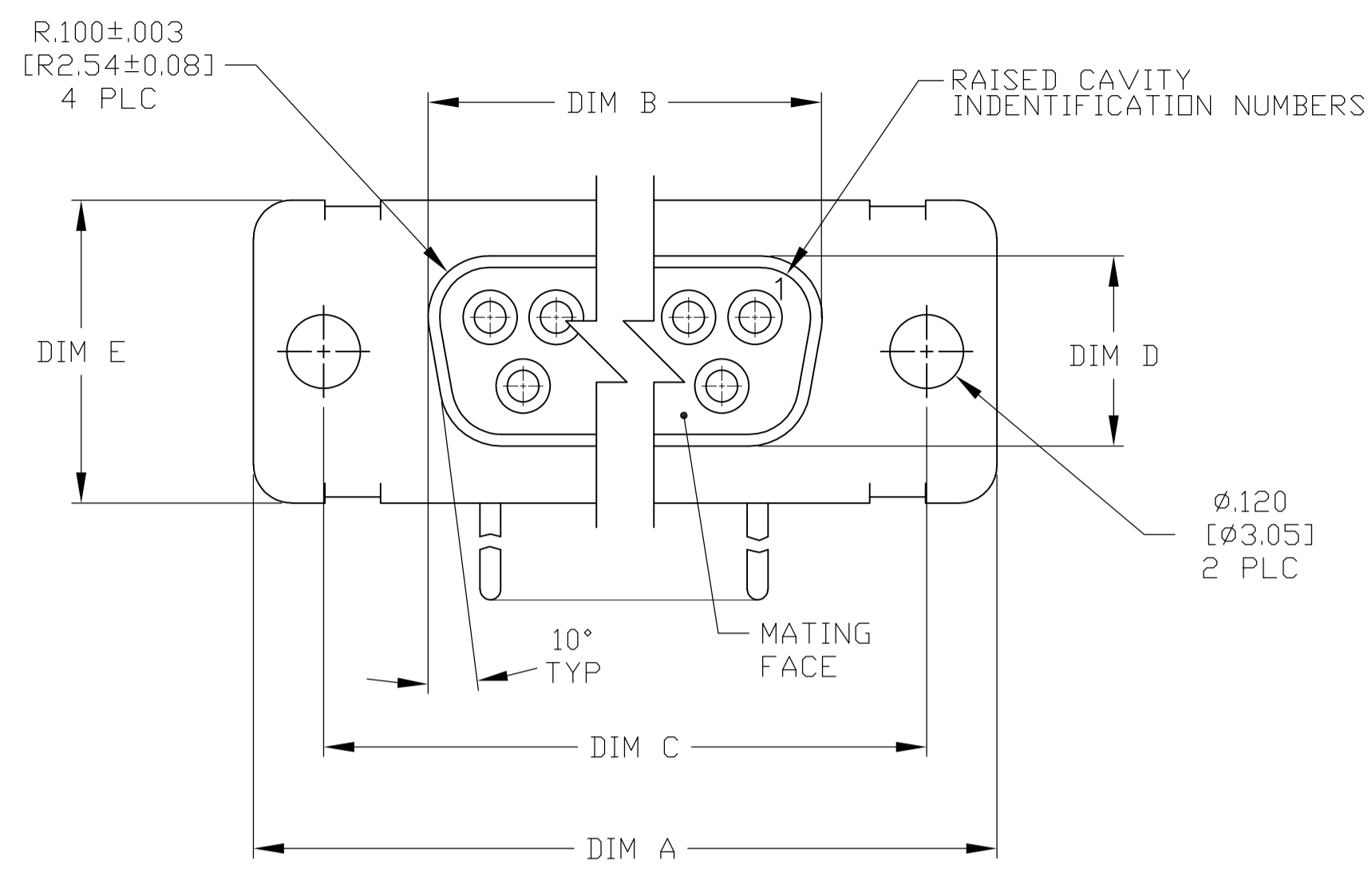
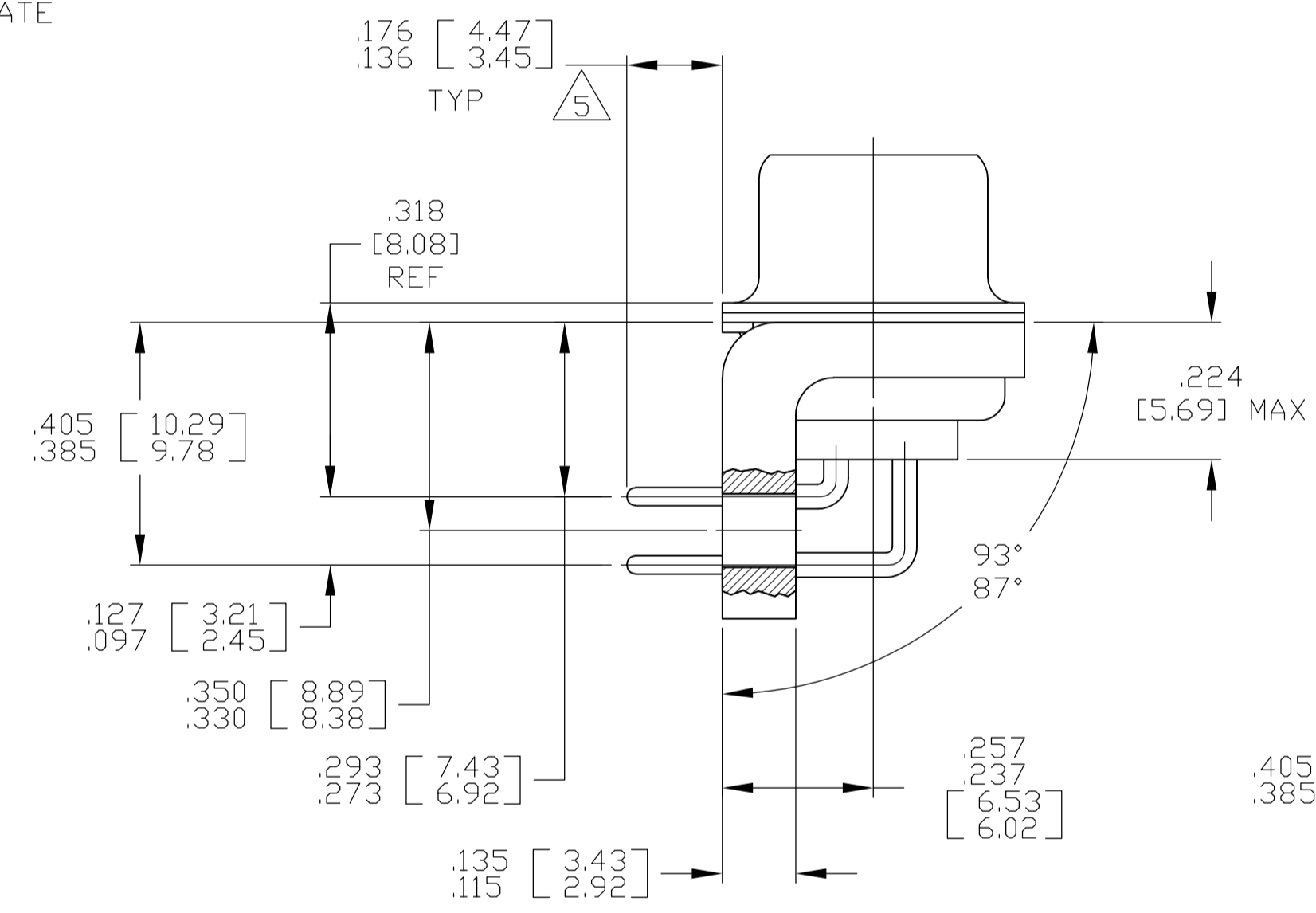
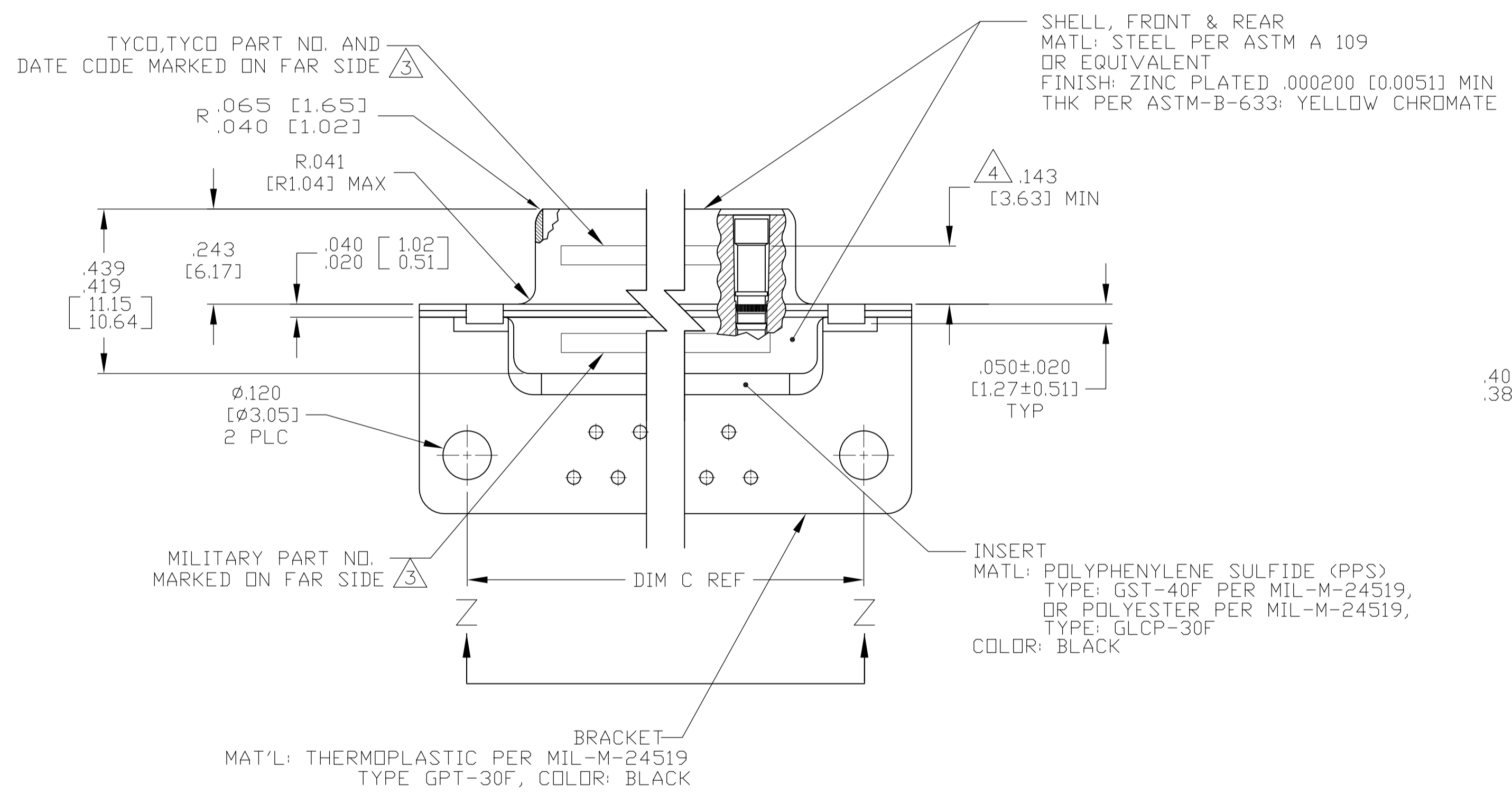

SHELL SIZES 1 THRU 4 CONTACT CONFIGURATION

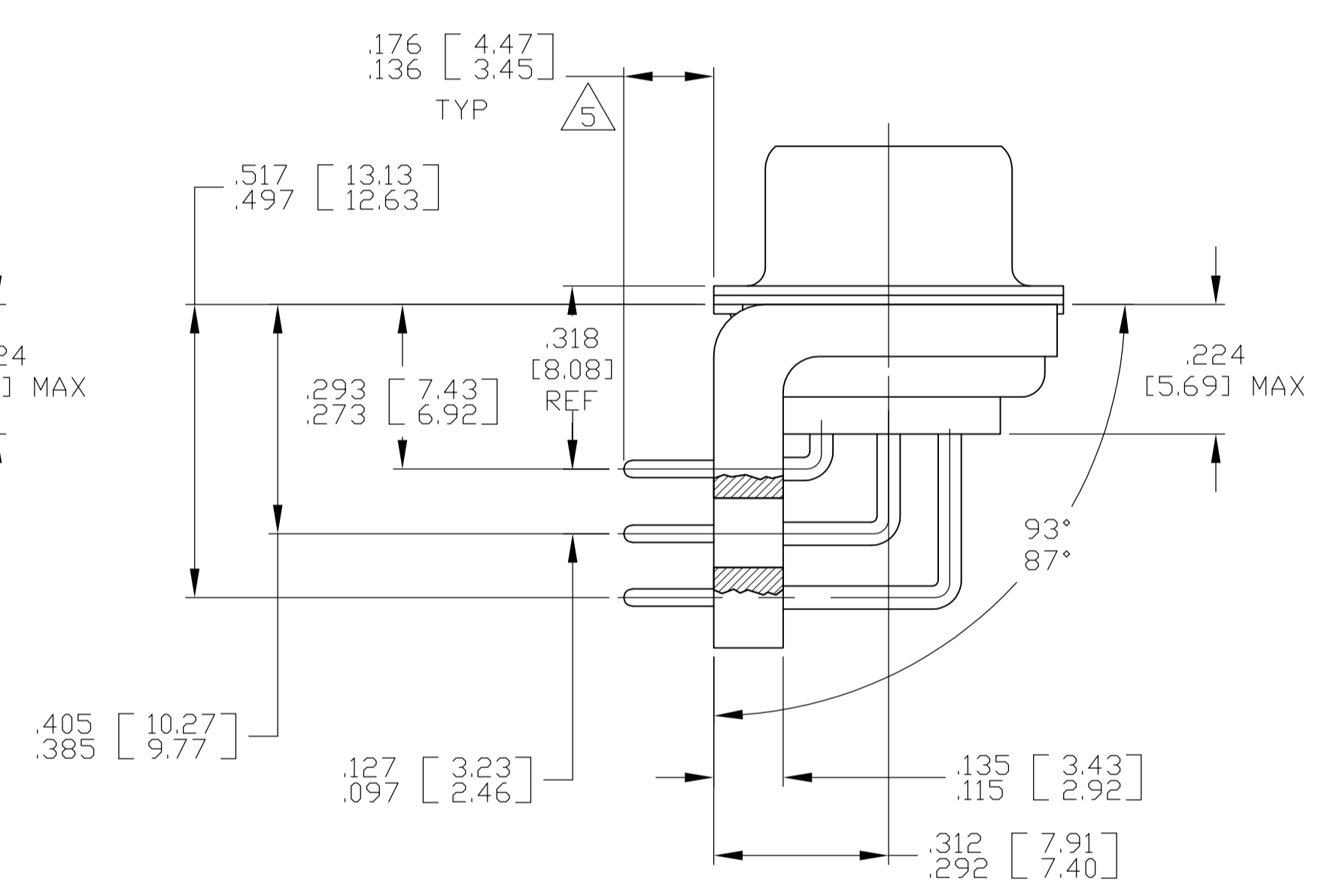

SHELL SIZE 5 CONTACT CONFIGURATION

.030 [0.76] MAX EXTENSION PERMISSIBLE DUE TO SOLDER DIPPING

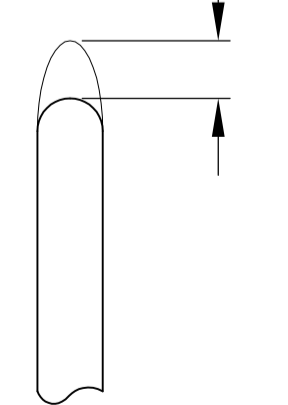

DETAIL K  
SCALE 10:1  
FOR 1757844-6 THRU -10 ONLY

.544 [13.82]	2.188 [55.58]	.620 [15.75]	.428 [10.87]	2.411 [61.24]	2.069 [52.55]	2.650 [67.31]
.524 [13.31]	2.168 [55.07]	.590 [14.99]	.418 [10.62]	2.401 [60.99]	2.059 [52.30]	2.620 [66.55]
.432 [10.97]	2.282 [57.96]	.509 [12.93]	.316 [8.03]	2.505 [63.63]	2.164 [54.97]	2.744 [69.70]
.412 [10.46]	2.262 [57.45]	.479 [12.17]	.306 [7.77]	2.495 [63.37]	2.154 [54.71]	2.714 [68.94]
.432 [10.97]	1.635 [41.53]	.509 [12.93]	.316 [8.03]	1.857 [47.17]	1.516 [38.51]	2.103 [53.42]
.412 [10.46]	1.615 [41.02]	.479 [12.17]	.306 [7.77]	1.847 [46.91]	1.506 [38.25]	2.073 [52.65]
.432 [10.97]	1.093 [27.76]	.509 [12.93]	.316 [8.03]	1.317 [33.45]	.976 [24.79]	1.556 [39.52]
.412 [10.46]	1.073 [27.25]	.479 [12.17]	.306 [7.77]	1.307 [33.20]	.966 [24.54]	1.526 [38.76]
.432 [10.97]	.769 [19.53]	.509 [12.93]	.316 [8.03]	.989 [25.12]	.648 [16.46]	1.228 [31.19]
.412 [10.46]	.749 [19.02]	.479 [12.17]	.306 [7.77]	.979 [24.87]	.638 [16.21]	1.198 [30.43]
.544 [13.82]	2.188 [55.58]	.620 [15.75]	.428 [10.87]	2.411 [61.24]	2.069 [52.55]	2.650 [67.31]
.524 [13.31]	2.168 [55.07]	.590 [14.99]	.418 [10.62]	2.401 [60.99]	2.059 [52.30]	2.620 [66.55]
.432 [10.97]	2.282 [57.96]	.509 [12.93]	.316 [8.03]	2.505 [63.63]	2.164 [54.97]	2.744 [69.70]
.412 [10.46]	2.262 [57.45]	.479 [12.17]	.306 [7.77]	2.495 [63.37]	2.154 [54.71]	2.714 [68.94]
.432 [10.97]	1.635 [41.53]	.509 [12.93]	.316 [8.03]	1.857 [47.17]	1.516 [38.51]	2.103 [53.42]
.412 [10.46]	1.615 [41.02]	.479 [12.17]	.306 [7.77]	1.847 [46.91]	1.506 [38.25]	2.073 [52.65]
.432 [10.97]	1.093 [27.76]	.509 [12.93]	.316 [8.03]	1.317 [33.45]	.976 [24.79]	1.556 [39.52]
.412 [10.46]	1.073 [27.25]	.479 [12.17]	.306 [7.77]	1.307 [33.20]	.966 [24.54]	1.526 [38.76]
.432 [10.97]	.769 [19.53]	.509 [12.93]	.316 [8.03]	.989 [25.12]	.648 [16.46]	1.228 [31.19]
.412 [10.46]	.749 [19.02]	.479 [12.17]	.306 [7.77]	.979 [24.87]	.638 [16.21]	1.198 [30.43]

DIM J	DIM H	DIM E	DIM D	DIM C	DIM B	DIM A	INSERT ARRANGEMENT	NO OF POS	SHELL SIZE	MILITARY P/N ON CONNECTOR	TYCO P/N MARKED ON CONNECTOR	TYCO PART NO.
.544 [13.82]	2.188 [55.58]	.620 [15.75]	.428 [10.87]	2.411 [61.24]	2.069 [52.55]	2.650 [67.31]	MS18277-1	50	5	M24308/23-47Z	1757844-5	1-1757844-0
.524 [13.31]	2.168 [55.07]	.590 [14.99]	.418 [10.62]	2.401 [60.99]	2.059 [52.30]	2.620 [66.55]	MS18276-1	37	4	M24308/23-46Z	1757844-4	1757844-9
.432 [10.97]	2.282 [57.96]	.509 [12.93]	.316 [8.03]	2.505 [63.63]	2.164 [54.97]	2.744 [69.70]	MS18275-1	25	3	M24308/23-45Z	1757844-3	1757844-8
.412 [10.46]	2.262 [57.45]	.479 [12.17]	.306 [7.77]	2.495 [63.37]	2.154 [54.71]	2.714 [68.94]	MS18274-1	15	2	M24308/23-44Z	1757844-2	1757844-7
.432 [10.97]	1.635 [41.53]	.509 [12.93]	.316 [8.03]	1.857 [47.17]	1.516 [38.51]	2.103 [53.42]	MS18273-1	9	1	M24308/23-43Z	1757844-1	1757844-6
.412 [10.46]	1.615 [41.02]	.479 [12.17]	.306 [7.77]	1.847 [46.91]	1.506 [38.25]	2.073 [52.65]	MS18277-1	50	5	M24308/23-47Z	1757844-5	1757844-5
.432 [10.97]	2.282 [57.96]	.509 [12.93]	.316 [8.03]	2.505 [63.63]	2.164 [54.97]	2.744 [69.70]	MS18276-1	37	4	M24308/23-46Z	1757844-4	1757844-4
.412 [10.46]	2.262 [57.45]	.479 [12.17]	.306 [7.77]	2.495 [63.37]	2.154 [54.71]	2.714 [68.94]	MS18275-1	25	3	M24308/23-45Z	1757844-3	1757844-3
.432 [10.97]	1.635 [41.53]	.509 [12.93]	.316 [8.03]	1.857 [47.17]	1.516 [38.51]	2.103 [53.42]	MS18274-1	15	2	M24308/23-44Z	1757844-2	1757844-2
.412 [10.46]	1.615 [41.02]	.479 [12.17]	.306 [7.77]	1.847 [46.91]	1.506 [38.25]	2.073 [52.65]	MS18273-1	9	1	M24308/23-43Z	1757844-1	1757844-1

THIS DRAWING IS A CONTROLLED DOCUMENT.

DMN: C.C. THOMAS 3-22-06  
CHK: D. MILLER 3-27-06  
APPV: D. MILLER 3-27-06

RECEPTACLE ASSEMBLY, AMPLITE, RT ANGLE, SERIES 109, SIZE 1 THRU 5

SCALE: 4:1 SHEET 1 OF 2 REV A

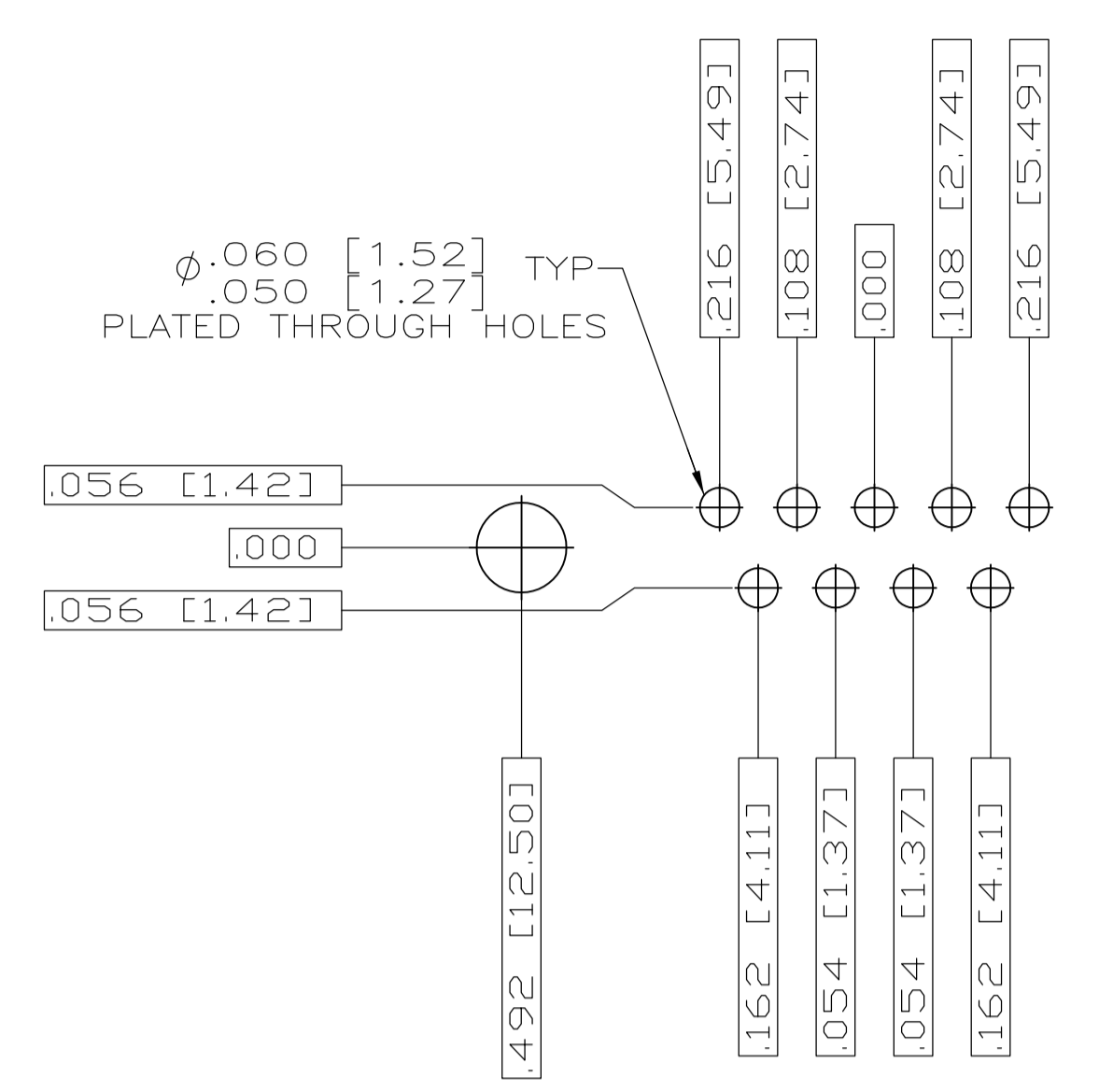

RECOMMENDED P.C. BOARD LAYOUT  
SHELL SIZE 1 (9 POSITION) ⚠

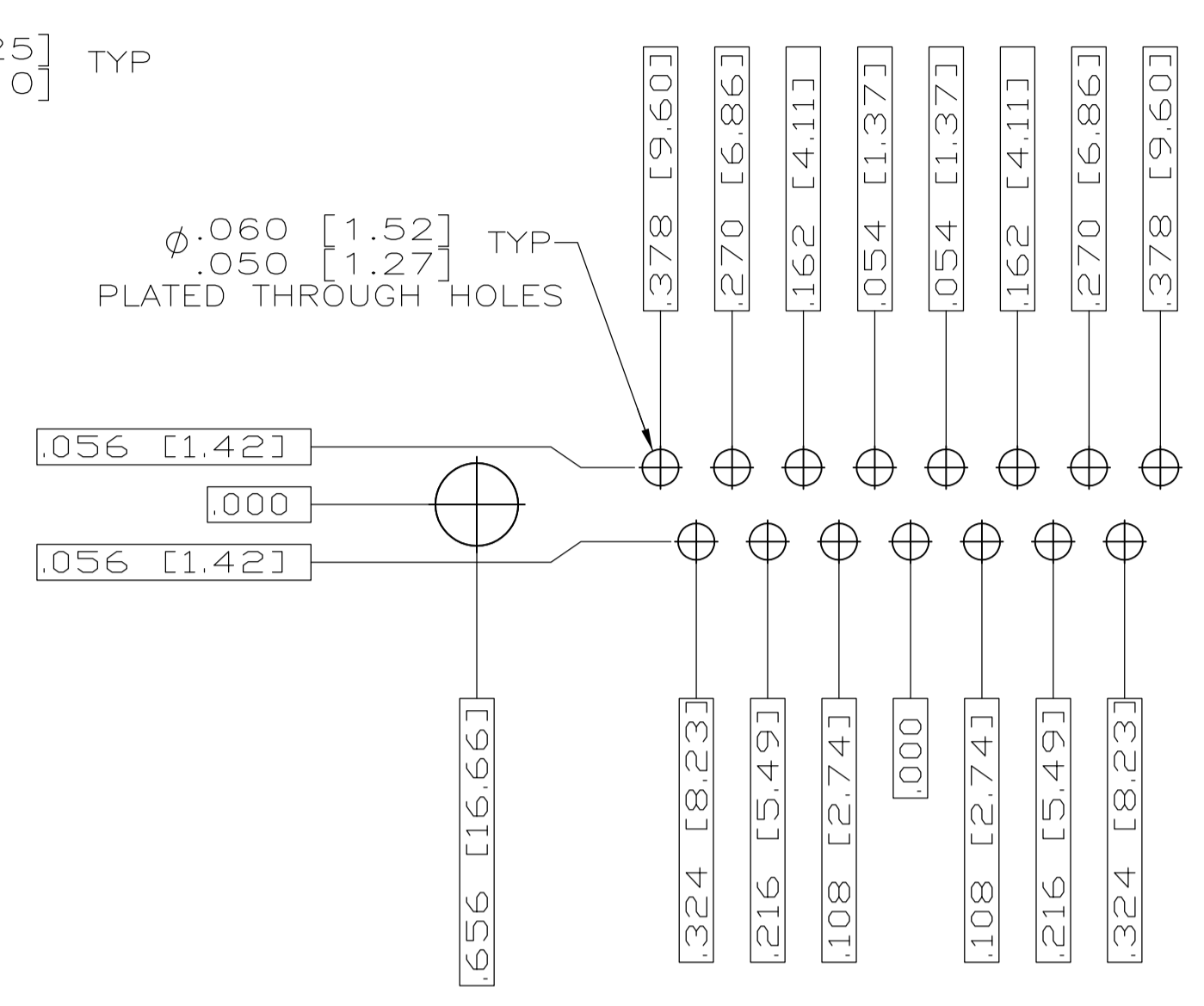

RECOMMENDED P.C. BOARD LAYOUT  
SHELL SIZE 2 (15 POSITION) ⚠

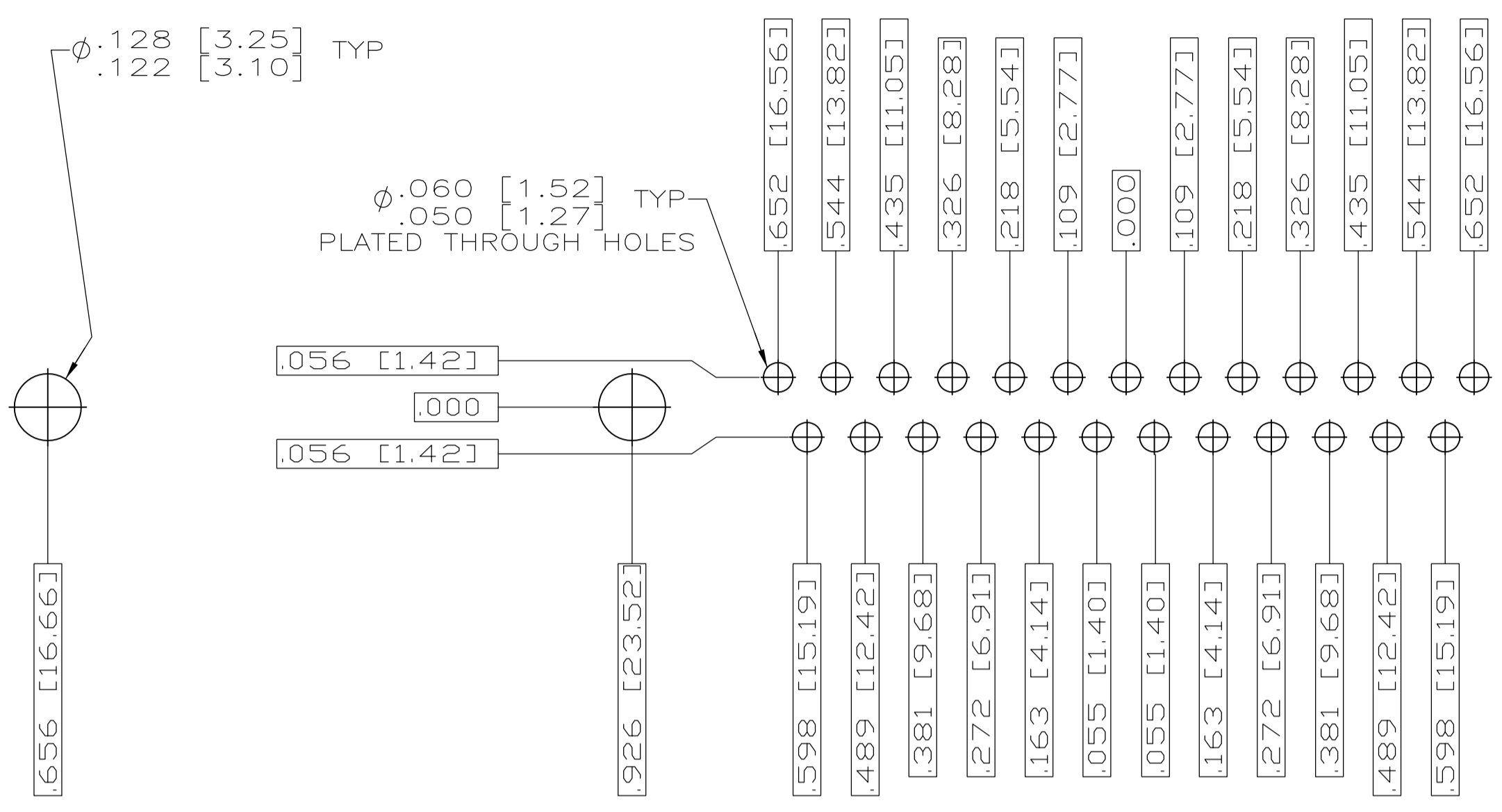

RECOMMENDED P.C. BOARD LAYOUT  
SHELL SIZE 3 (25 POSITION) ⚠

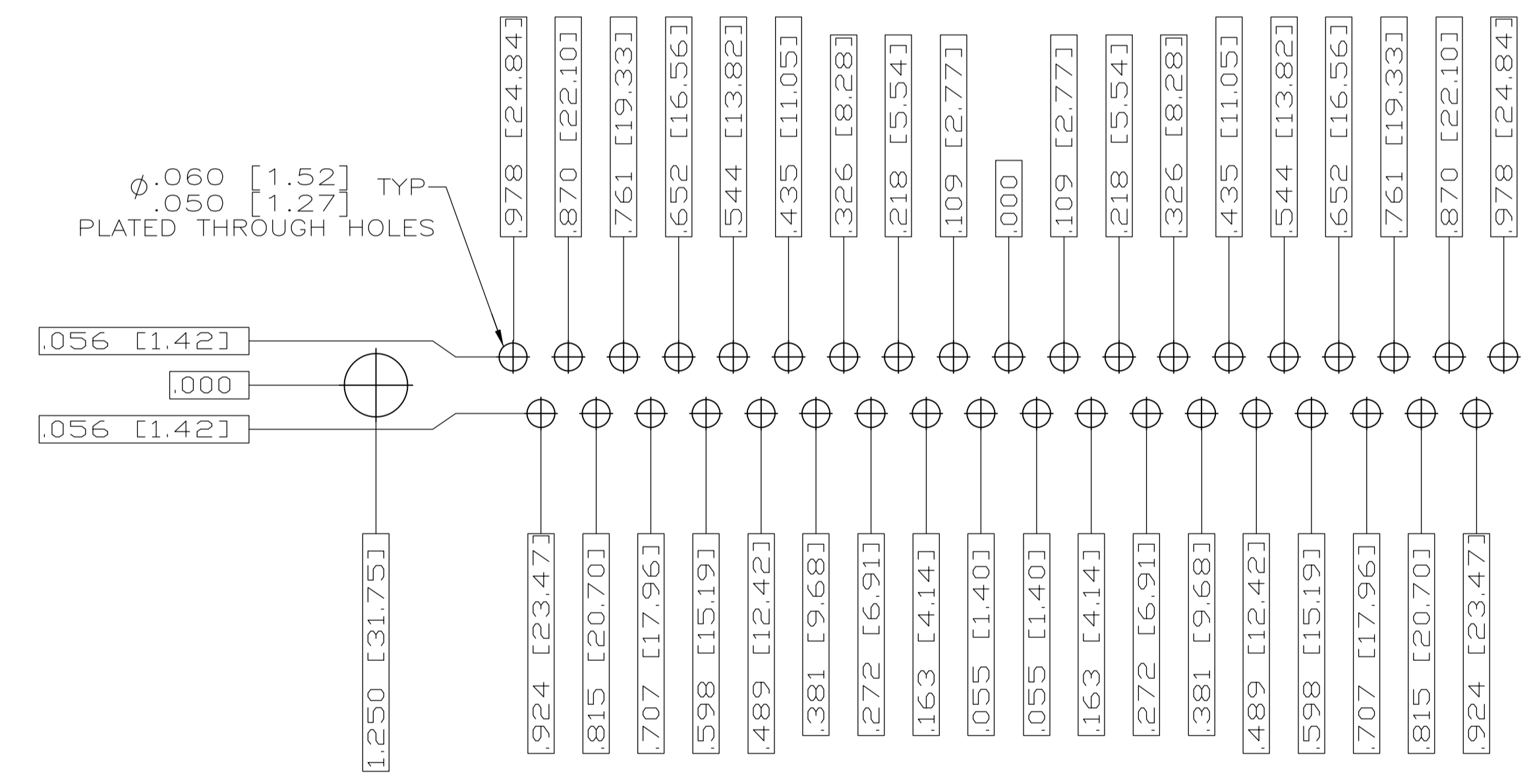

RECOMMENDED P.C. BOARD LAYOUT  
SHELL SIZE 4 (37 POSITION) ⚠

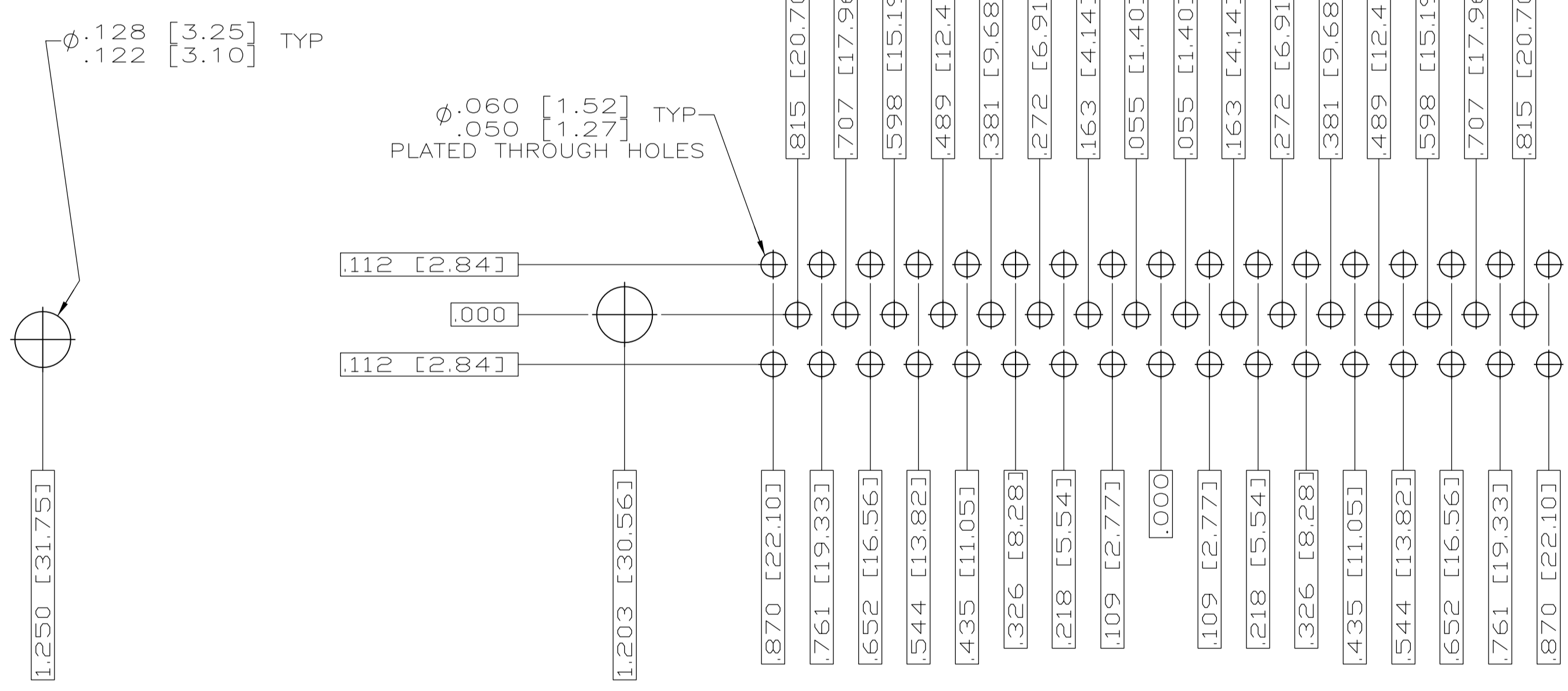

RECOMMENDED P.C. BOARD LAYOUT  
SHELL SIZE 5 (50 POSITION) ⚠

THIS DRAWING IS A CONTROLLED DOCUMENT.		DN C.C.THOMAS	3-22-06	TE Connectivity
DIMENSIONS: INCHES		CHK D.HOFFMAN	3-27-06	
TOLERANCES UNLESS OTHERWISE SPECIFIED:		APVD D.MILLER	3-27-06	NAME
0 PLC ± .010 1 PLC ± .005 2 PLC ± .002 3 PLC ± .001 4 PLC ± .0005 ANGLES ± .1°		PRODUCT SPEC		RECEPTACLE ASSEMBLY,AMPLITE RIGHT ANGLE,SERIES 109,SIZE 1 THRU 5
MATERIAL SEE CALLOUTS		FINISH SEE CALLOUTS		APPLICATION SPEC
WEIGHT		SIZE A1		RESTRICTED TO
CUSTOMER DRAWING		CAGE CODE 00779		DRAWING NO 1757844
SCALE 4:1		SHEET 2 OF 2		REV A