

# BTS50025-1TEA Shield

## About this document

### Scope and purpose

This document describes how to use the High Side Switch Shield with BTS50025-1TEA for Arduino.

### Intended audience

Engineers, hobbyists and students who want to add powerful High Side Switches to Arduino projects.

## Table of contents

<b>About this document</b> .....	<b>1</b>
<b>Table of contents</b> .....	<b>1</b>
<b>1 BTS50025-1TEA Shield introduction</b> .....	<b>2</b>
1.1 BTS50025-1TEA Shield overview .....	2
1.1 Key features .....	3
1.2 Block diagram.....	4
1.3 Typical connection .....	5
1.3.1 Typical connection with a PWM signal from a waveform generator.....	5
1.3.2 Typical connection with Arduino UNO (or DUE) board.....	5
<b>2 Software utilisation</b> .....	<b>6</b>
<b>3 Board connectors description</b> .....	<b>9</b>
3.1 Power connectors .....	9
3.2 ARDUINO connector .....	9
3.2.1 Connector J1 .....	9
3.2.2 Connector J2 .....	9
3.2.3 Connector J3 .....	10
3.2.4 Connector J4 .....	10
3.3 Test points .....	10
3.3.1.1 Schematic.....	11
<b>Revision history</b> .....	<b>12</b>

### 1 BTS50025-1TEA Shield introduction

#### 1.1 BTS50025-1TEA Shield overview

The 12V IPS shield with four BTS50025-1TEA from Infineon Technologies is a flexible evaluation board dedicated to drive loads. This board is compatible with Infineon’s XMC1100 Boot Kit and the Arduino UNO.

The shield can be controlled either with the general logic IO-Ports of a microcontroller or with a PWM signal generated by a waveform generator.

It includes typical schematic to control the four BTS50025-1TEA. This shield offers a quick evaluation of the BTS50025-1TEA, the analog current feedback and all the protections like short circuits.

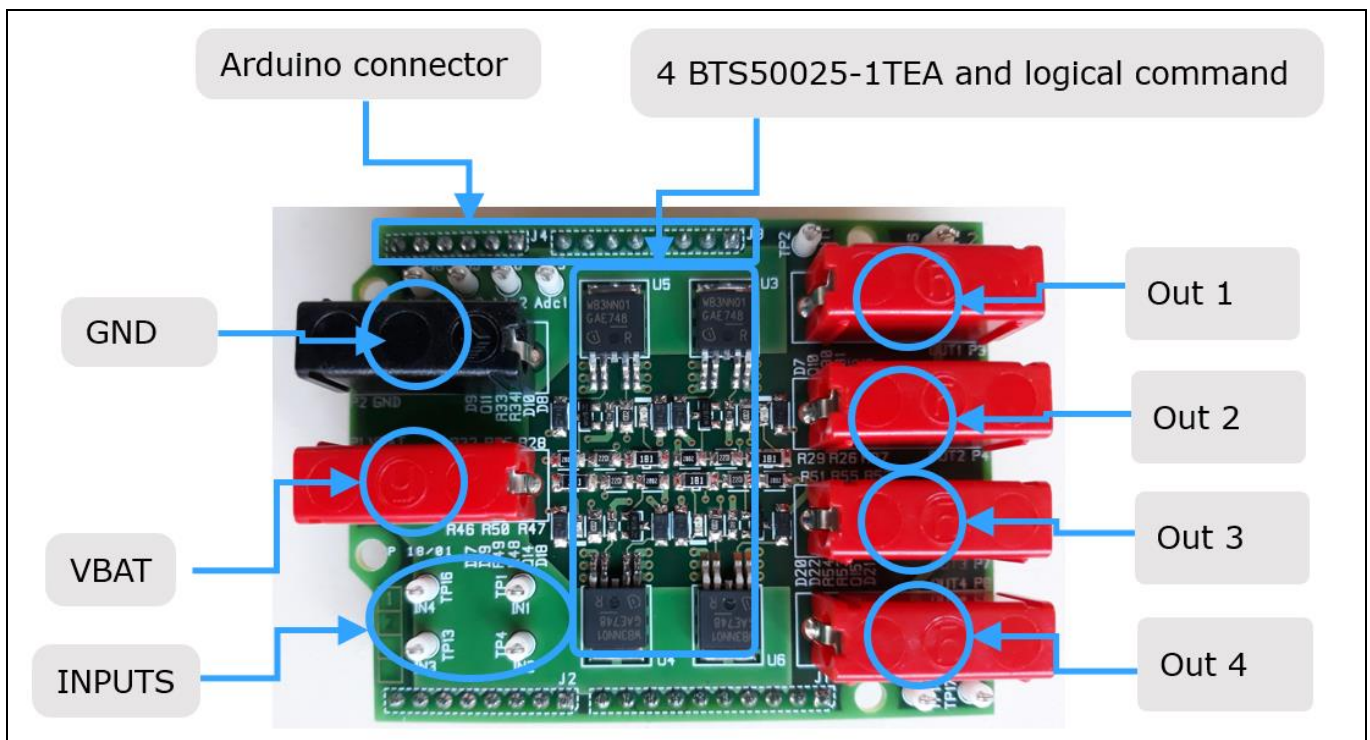

Figure 1 Board overview

BTS50025-1TEA Shield introduction

1.1 Key features

- Demoboard is able to provide a continuous current of up to 25A to 4 different loads (12V)
- A LED will turn ON to indicate that BTS50025-1TEA is switched ON.
- Current feedback measurement on demoboard by  $R_{ifb} = 1k\Omega$ .
- Output voltage, input logic and analog current feedback can be measured externally with test points.

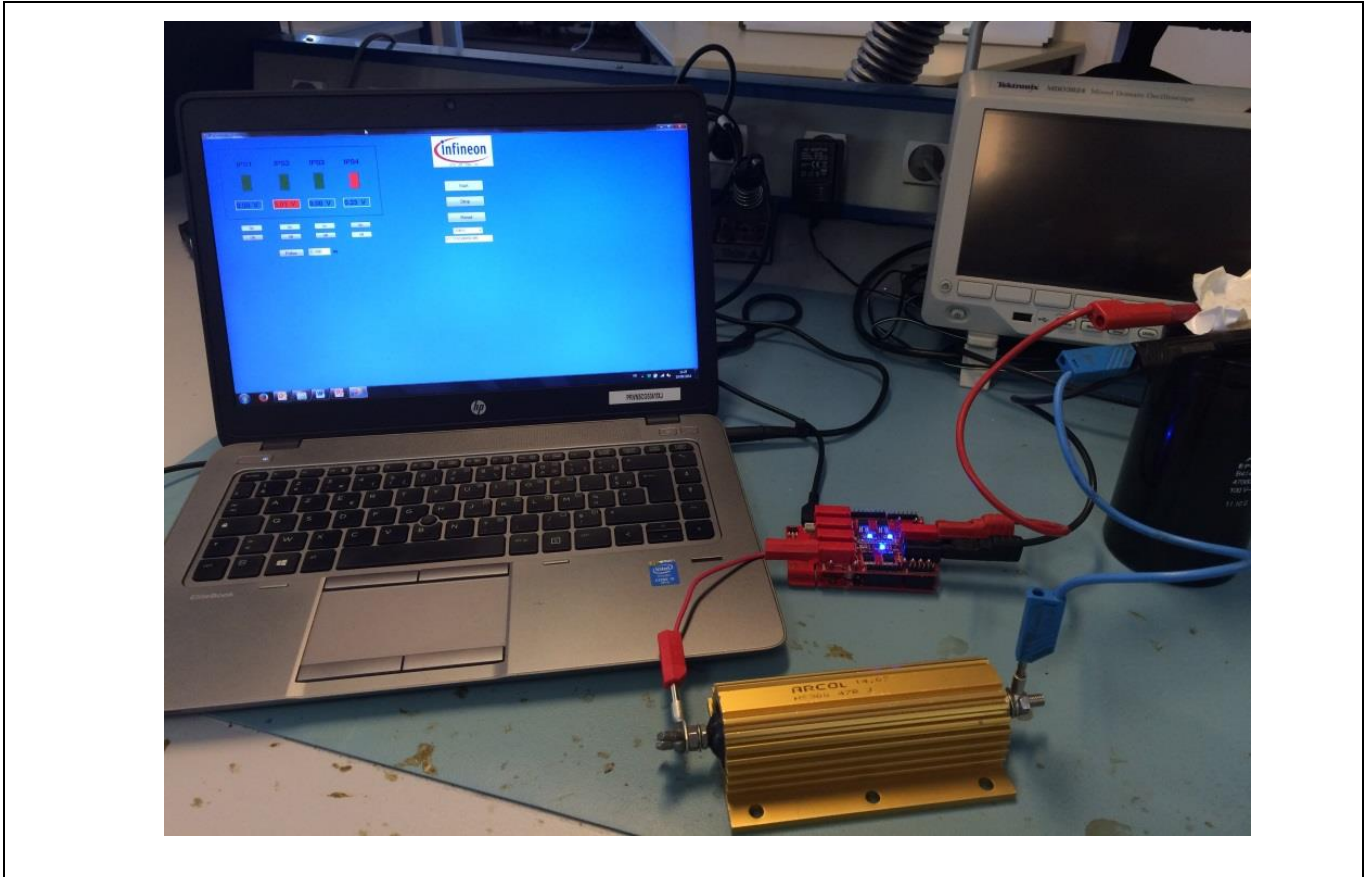
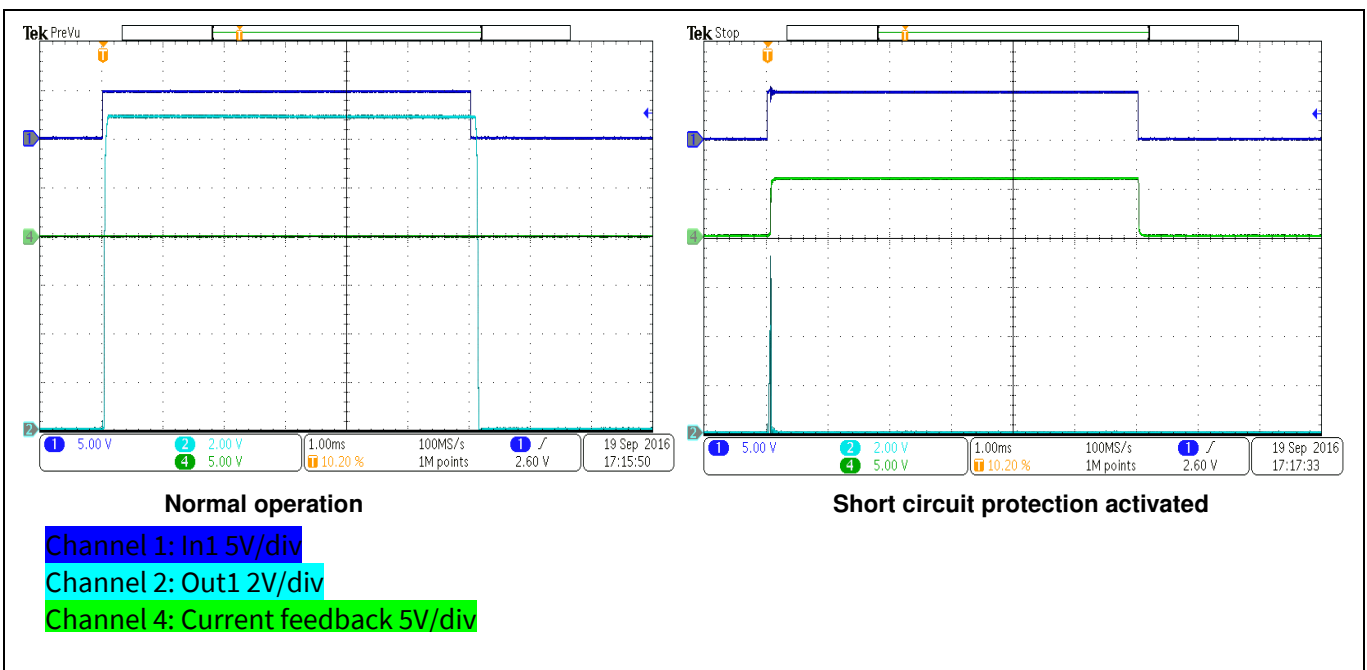

Figure 2 Load activation with demoboard BTS50025-1TEA shield



BTS50025-1TEA Shield introduction

Figure 3 Waveforms in normal operation and in short-circuit condition.

1.2 Block diagram

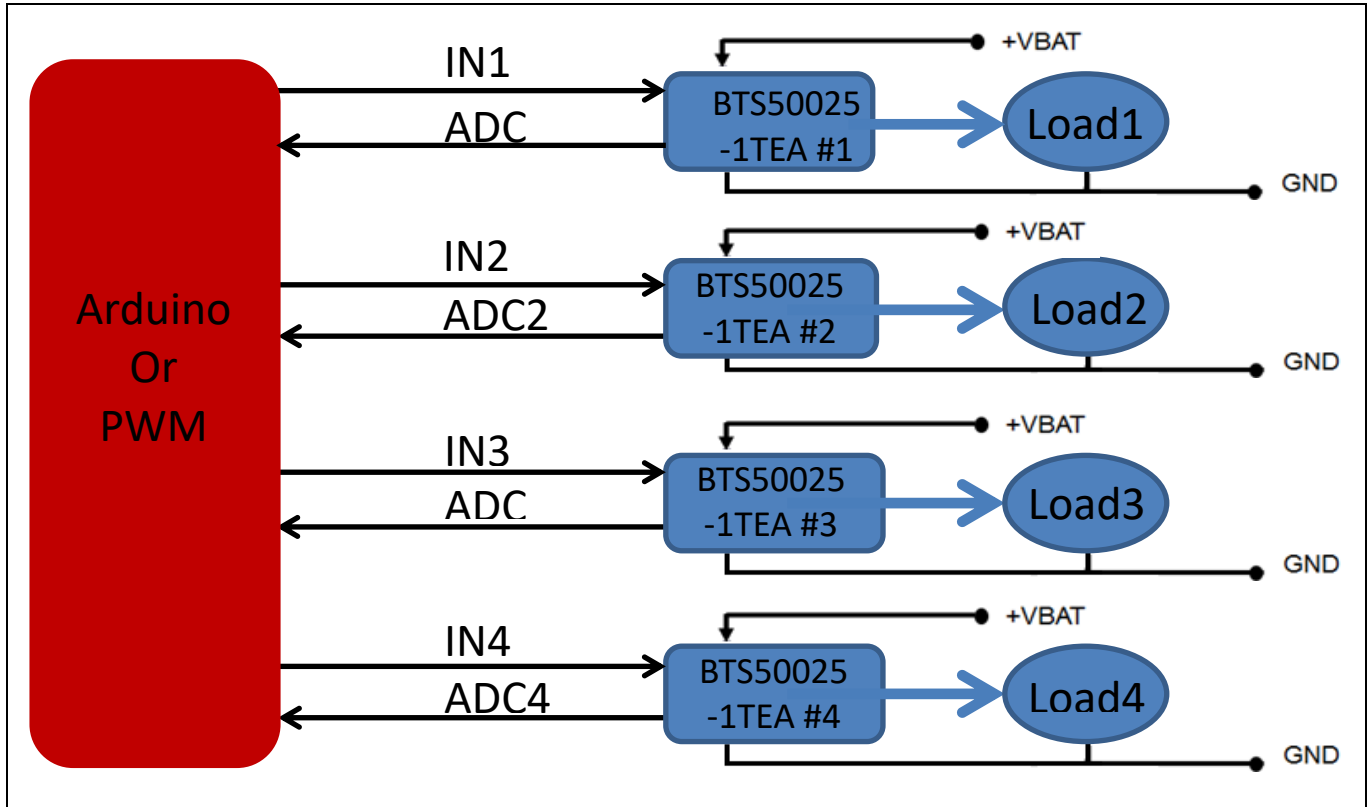

Figure 4 Block diagram

BTS50025-1TEA Shield introduction

1.3 Typical connection

1.3.1 Typical connection with a PWM signal from a waveform generator

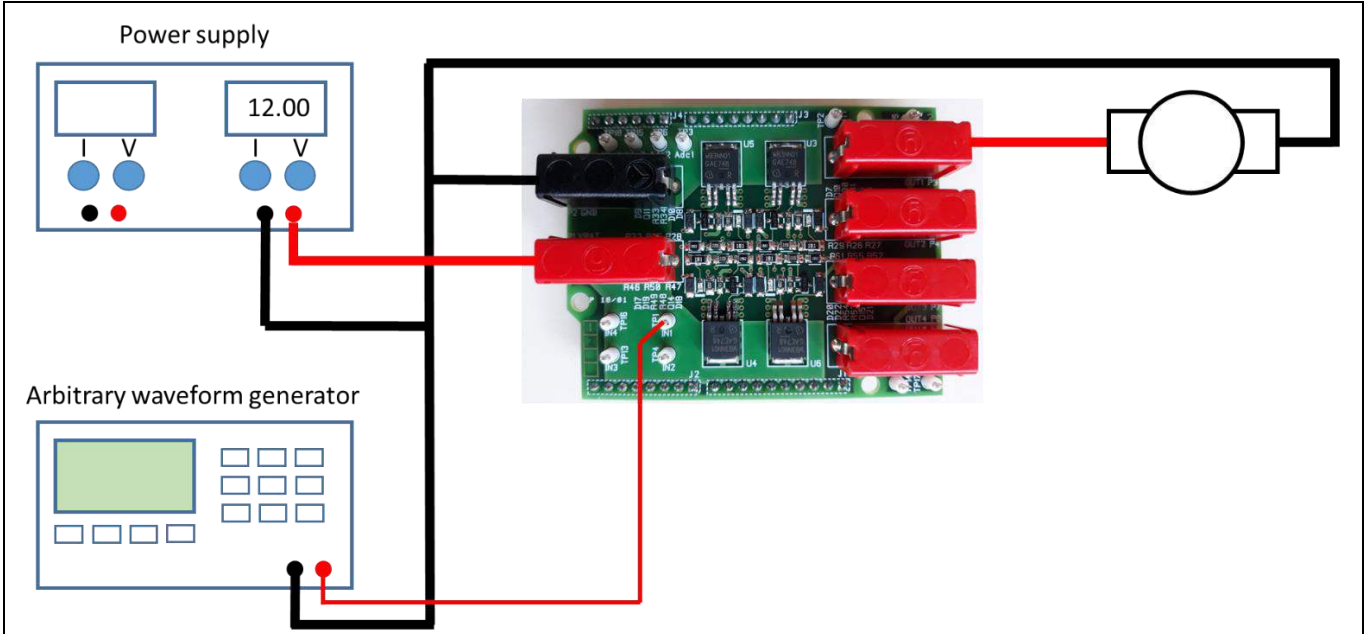

Figure 5 Standalone connection

1.3.2 Typical connection with Arduino UNO (or DUE) board

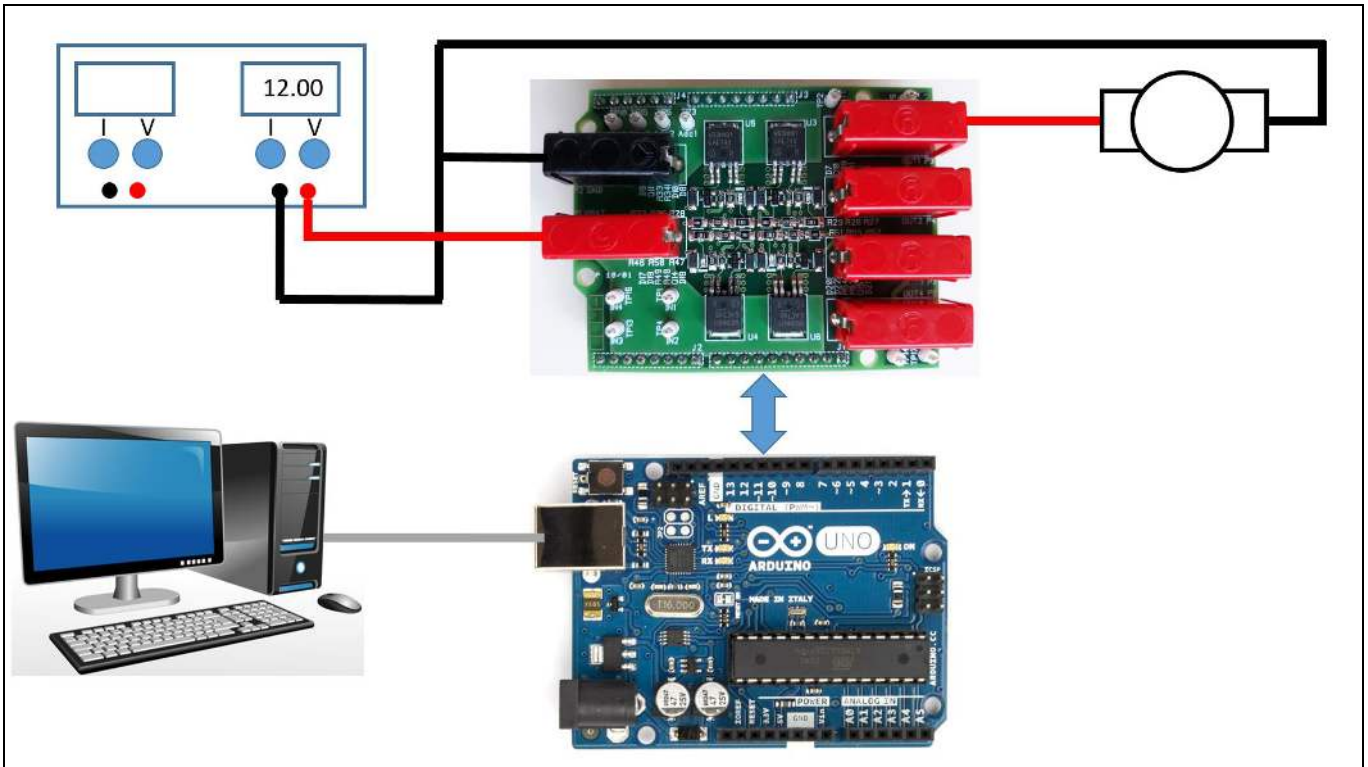

Figure 6 Connection with Arduino

Introduction to the control software

## 2 Introduction to the control software

- An executable file is provided with this user manual: **Demoboard\_Aiko\_Universal.exe**. It allows to drive the four BTS50025-1TEA from an Arduino board, with various control modes (DC, pulse, PWM) and to capture the current measured on the IS pin of each BTS50025-1TEA.
- Installation:

- First, configure your Arduino board: use the right project file and open it in the Arduino IDE:
  - For Arduino UNO, use **Aiko\_UART\_ArduinoUNO.ino**
  - For Arduino DUE, use **Aiko\_UART\_ArduinoDUE.ino**
- Compile the project and program your board.
- Launch “**Demoboard\_Aiko\_Universal**” software on your PC, connected over USB to the Arduino board.
- Select the right board from the drop down menu:

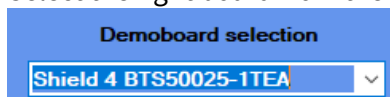

- Click on “Start” button to initiate communication with the Arduino board.



- If it's not working, change the virtual com port number in the drop down menu:



and click again on the start button until the board is detected

- Once the communication is ready, the user interface becomes as shown below:

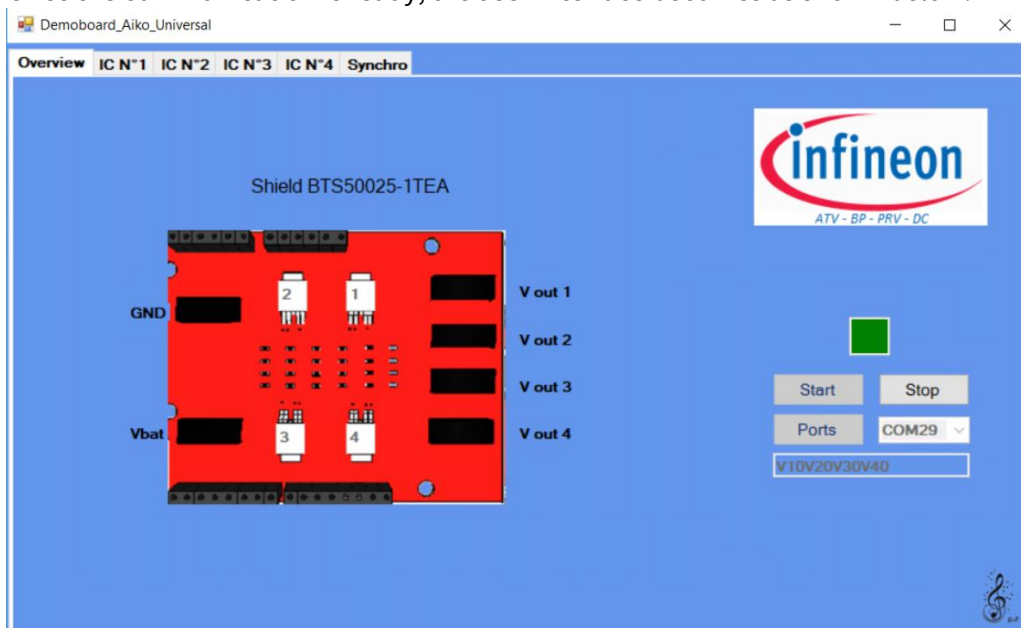



## Introduction to the control software

- Driving the BTS50025-1TEA:

- Multiple folders allow to drive the four BTS50025-1TEAs:



- For each BTS50025-1TEA, three control modes are offered:

- DC/continuous mode
  - ON for a limited number of pulses (the pulse width is defined by the parameters in the PWM settings)
  - ON for an unlimited time in PWM mode, with 2 settings: Frequency (F) & duty cycle (DC)

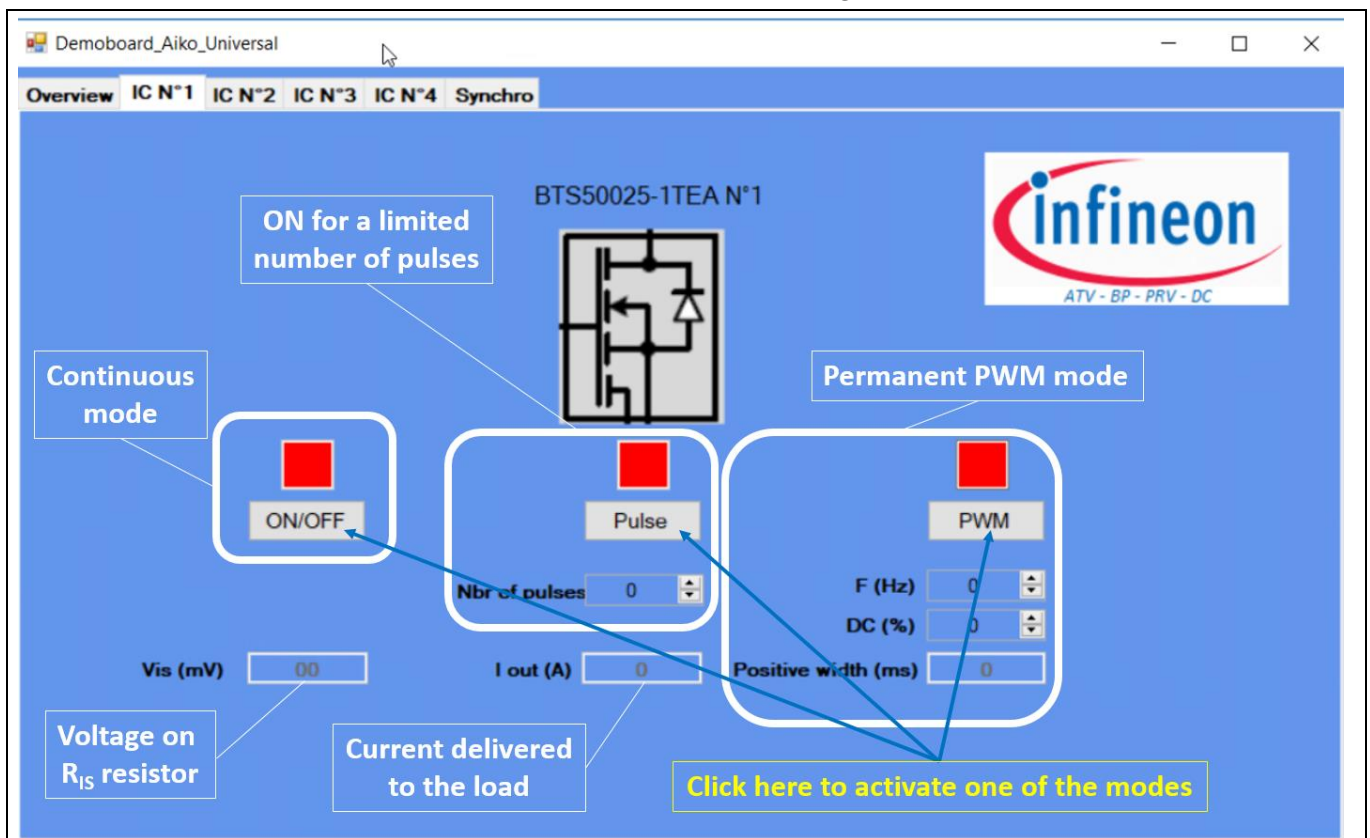

**Figure 7 Control Modes**

- An additional control mode is offered, to synchronize several BTS50025-1TEA on the board:
  - It is possible to decide which components among the four devices are synchronized
  - It is possible to configure a delay introduced between them
  - It is possible to activate a continuous ON mode at the end of the synchronized pulse mode
  - The settings ( PWM frequency & Duty cycle, number of pulses) are defined in the respective folders of each BTS50025-1TEA. The “Synchro” folder only configures the synchronous mode.

Introduction to the control software

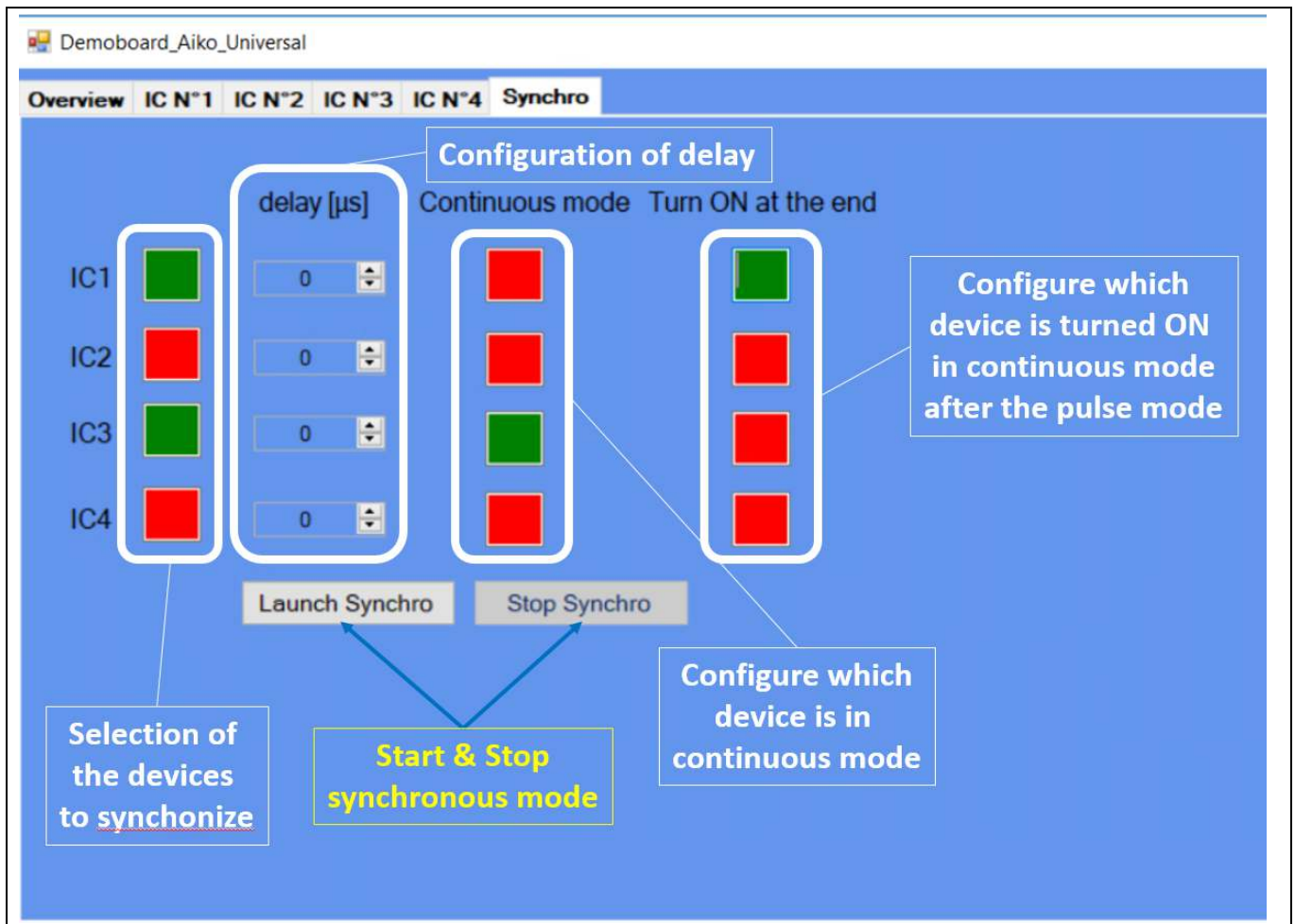

Figure 8 Synchronization of the four devices



Board connectors description

### 3 Board connectors description

#### 3.1 Power connectors

Name	Connector	Type	Description
VBAT	P1	Power supply	Positive power supply 12V
GND	P2	Ground power	Ground
OUT1	P3	Power output	Output 1
OUT2	P4	Power output	Output 2
OUT3	P7	Power output	Output 3
OUT4	P8	Power output	Output 4

#### 3.2 ARDUINO connector

##### 3.2.1 Connector J1

Name	Pin	Type	Description / Arduino pin name
-	1	No connected	-
-	2	No connected	-
-	3	No connected	-
Gnd	4	Digital Ground	Ground
-	5	No connected	-
IN1	6	Digital Input	Pin activation for IPS 1 / Digital 12
IN2	7	Digital Input	Pin activation for IPS 2 / Digital 11
IN3	8	Digital Input	Pin activation for IPS 3 / Digital 10
IN4	9	Digital Input	Pin activation for IPS 4 / Digital 9
-	10	No connected	-

##### 3.2.2 Connector J2

Name	Pin	Type	Description
-	1	No connected	-
-	2	No connected	-
-	3	No connected	-
-	4	No connected	-
-	5	No connected	-
-	6	No connected	-
-	7	No connected	-
-	8	No connected	-

**Board connectors description**

**3.2.3 Connector J3**

Name	Pin	Type	Description
-	1	No connected	-
-	2	No connected	-
-	3	No connected	-
-	4	No connected	-
-	5	No connected	-
Gnd	6	Digital Ground	Ground
Gnd	7	Digital Ground	Ground
-	8	No connected	-

**3.2.4 Connector J4**

Name	Pin	Type	Description/ Arduino pin name
Adc1	1	Analog input	Analog measurement for the current feedback 1 / A0
Adc2	2	Analog input	Analog measurement for the current feedback 2 / A1
Adc3	3	Analog input	Analog measurement for the current feedback 3 / A2
Adc4	4	Analog input	Analog measurement for the current feedback 4 / A3
-	5	No connected	-
-	6	No connected	-

**3.3 Test points**

Name	Pin	Type	Description
IN1	1	Digital Input	Pin activation for IPS 1
IN2	2	Digital Input	Pin activation for IPS 2
IN3	3	Digital Input	Pin activation for IPS 3
IN4	4	Digital Input	Pin activation for IPS 4
Adc1	5	Analog input	Analog measurement for the current feedback 1
Adc2	6	Analog input	Analog measurement for the current feedback 2
Adc3	7	Analog input	Analog measurement for the current feedback 3
Adc4	8	Analog input	Analog measurement for the current feedback 4
Out1	9	Analog power output	Analog power output from IPS 1
Out2	10	Analog power output	Analog power output from IPS 2
Out3	11	Analog power output	Analog power output from IPS 3
Out4	12	Analog power output	Analog power output from IPS 4

Board connectors description

3.3.1.1 Schematic

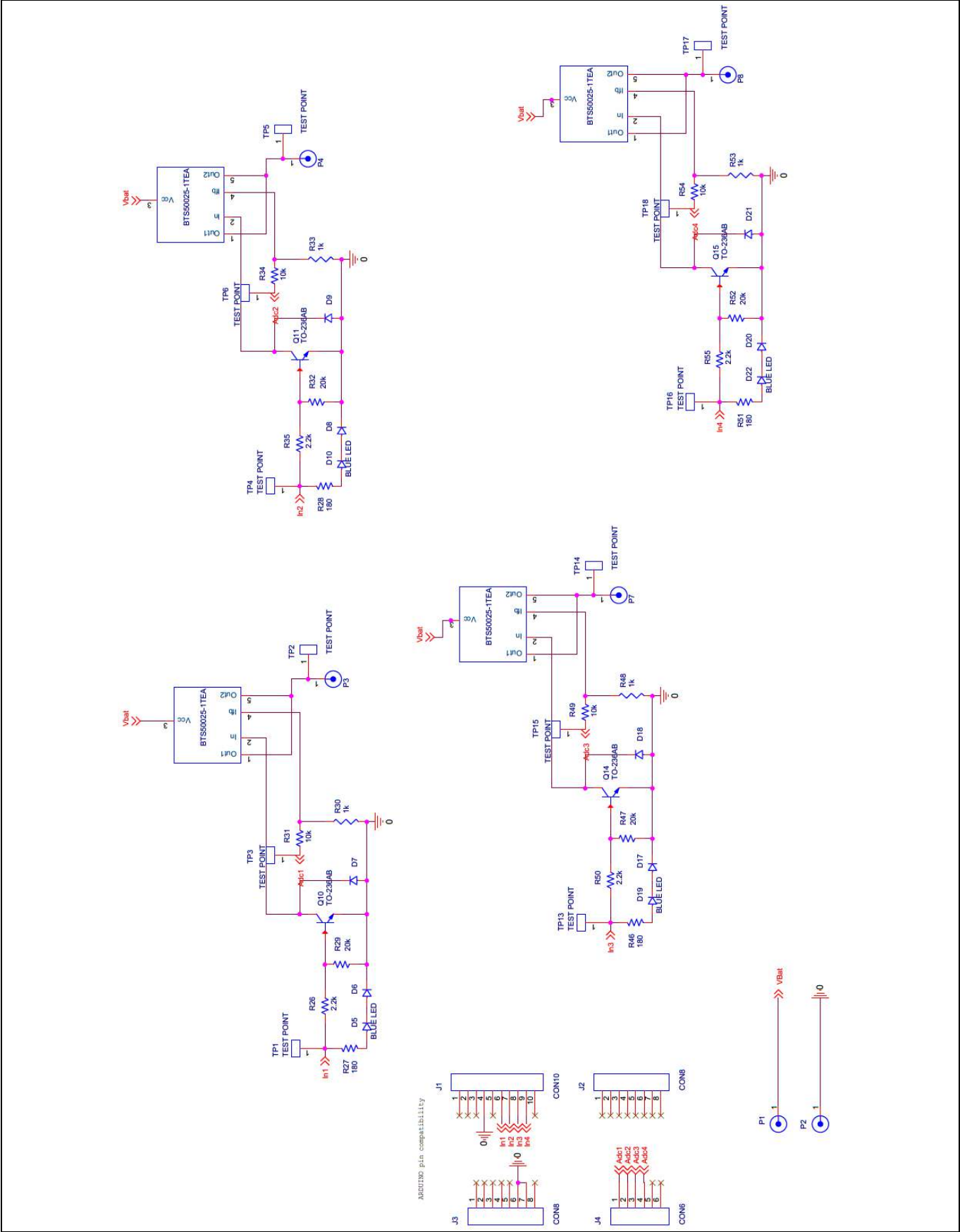

Figure 9 Schematic

---

**Board connectors description****Revision history**

<b>Document version</b>	<b>Date of release</b>	<b>Description of changes</b>
Rev 1.0	2019-05-10	
Rev 1.1	2020-04-29	Minor editorial changes Section on control software modified to match the new SW version

**Trademarks**

All referenced product or service names and trademarks are the property of their respective owners.

**Edition 2020-04-29**

**Published by**

**Infineon Technologies AG**

**81726 Munich, Germany**

**© 2020 Infineon Technologies AG.**

**All Rights Reserved.**

**Do you have a question about this document?**

**Email: [erratum@infineon.com](mailto:erratum@infineon.com)**

**Document reference**

**User Manual**

**IMPORTANT NOTICE**

The information given in this document shall in no event be regarded as a guarantee of conditions or characteristics ("Beschaffheitsgarantie").

With respect to any examples, hints or any typical values stated herein and/or any information regarding the application of the product, Infineon Technologies hereby disclaims any and all warranties and liabilities of any kind, including without limitation warranties of non-infringement of intellectual property rights of any third party.

In addition, any information given in this document is subject to customer's compliance with its obligations stated in this document and any applicable legal requirements, norms and standards concerning customer's products and any use of the product of Infineon Technologies in customer's applications.

The data contained in this document is exclusively intended for technically trained staff. It is the responsibility of customer's technical departments to evaluate the suitability of the product for the intended application and the completeness of the product information given in this document with respect to such application..

**WARNINGS**

Due to technical requirements products may contain dangerous substances. For information on the types in question please contact your nearest Infineon Technologies office.

Except as otherwise explicitly approved by Infineon Technologies in a written document signed by authorized representatives of Infineon Technologies' products may not be used in any applications where a failure of the product or any consequences of the use thereof can reasonably be expected to result in personal injury.