

TABLE OF CONTENTS

SHEET NO.	SHEET DESCRIPTION
1	NOTES
2	KEY CONFIGURATIONS
3	BLADE SEALED ASSEMBLY
4	SYSTEM PACKAGING
5-9	BOM

NOTES: VALID UNLESS OTHERWISE SPECIFIED

1. GENERAL:
- a. APPLICATION SPECIFICATION SEE: AS-33472-100
 CONTAINS: PRODUCT INTRODUCTION, PRODUCT SUMMARY, CONNECTOR ASSEMBLY, PACKAGING INFORMATION, CONNECTOR MATING, SERVICE INSTRUCTIONS, ELECTRICAL CONTINUITY CHECKING, CRIMPING, AND TROUBLESHOOTING.
 -DESIGNED TO MATE WITH RECEPTACLE SEALED ASSEMBLY SPECIFIED IN MOLEX DRAWING SD-33476-161 AND SD-33476-161 FOR SHORTING BAR APPLICATIONS RECEPTACLE SEALED ASSEMBLY CONFIGURATION MUST CONTAIN A PLR WITH SHORTING BAR LIFTER.
 -FOR 15mm BLADE TERMINALS TO BE USED WITH THE SHORTING BAR CIRCUIT LOCATIONS SEE MOLEX DRAWING SD-31296-001.
 -SHORTING BAR TERMINALS TO BE USED WITH WIRE WITHIN DIAMETER RANGE OF 1.7mm TO 2.06mm.
 -SHORTING BAR TERMINAL CRIMP ANGLE MUST BE BETWEEN -14 DEG. AND +35 DEG. AFTER INSTALLATION INTO THE CONNECTOR ASSEMBLY. REFER TO MOLEX DRAWING SD-31296-001 FOR DETAILS.
 -FOR 15mm BLADE TERMINALS TO BE USED WITH THE NON-SHORTING BAR CIRCUIT LOCATIONS SEE MOLEX DRAWING SD-33000-004.
 -NON-SHORTING BAR TERMINALS TO BE USED WITH WIRE WITHIN DIAMETER RANGE OF 1.4mm TO 2.69mm.
 -FOR 2.8mm BLADE TERMINALS TO BE USED WITH THIS ASSEMBLY SEE TABLE.
 -2.8mm TERMINALS TO BE USED WITH WIRE WITHIN DIAMETER RANGE OF 150mm TO 330mm.
 -ASSEMBLY SHIPPED WITH PLR IN PRE-LOCK POSITION
 -IN THE EVENT THAT THE PLR IS FOUND IN THE SEATED (FINAL LOCK) POSITION, REFER TO MOLEX SPECIFICATION PS-34666-001, AVAILABLE AT www.molex.com OR <http://www.molex.com>
 -ASSEMBLY CONFORMS TO SAE/USCAR-2 REV.4 WITH THE FOLLOWING EXCEPTIONS:
 TERMINAL INSERTION FORCE FOR WIRE DIAMETER ABOVE 25mm NOT EXCEEDING 2.69mm SHALL EXCEED 5 NEWTONS.
 PLR REMOVAL FROM FINAL-LOCK TO PRE-LOCK SHALL NOT EXCEED 75 NEWTONS.

- b. PRODUCT SPECIFICATION SEE: PS-33476-000
 CONTAINS: PRODUCT INTRODUCTION, PRODUCT SUMMARY, RATINGS (CURRENT, TEMPERATURE, SEALING, AND FLAMMABILITY), AND PRODUCT VALIDATION.
- c. PART NUMBER SPECIFICATION PER MOLEX DRAWING PK-33000-514
- d. PARTS MUST BE IN COMPLIANCE TO MOLEX CHEMICAL SUBSTANCES FOR PRODUCTION AND PACKAGING SPECIFICATION: ES-40000-506
- e. DATA MUST BE SUBMITTED UNDER THE MOLEX PART NUMBER TO IMDS (COMPANY ID#13255)

2. DESIGN - MATERIALS:
- a. CONNECTOR HOUSING, GROMMET CAP, PLR: SPS/NYLON BLEND 20% GLASS FILLED
- b. MAT SEAL: INHERENTLY LUBRICATED SILICONE
- c. SHORTING BARS: STAINLESS STEEL

3. DESIGN - GEOMETRY:
- a. THIS IS A 100% CAD GENERATED PART, THE CAD MATHEMATICAL DATA IS THE MASTER FOR THIS PART, FOR DIMENSIONAL OR ANY INFORMATION NOT SHOWN ON THIS DRAWING, ANALYZE THE CAD MODEL.
- b. GEOMETRIC DIMENSIONS AND TOLERANCES PER ASME Y14.5M - 1994 EDGES AND UNDERMENSIONED DETAILS PER ISO15715 CORNERS SHOWN AS SHARP TO BE 0.2 MAX.
 LETTERING SHALL BE 0.15 MAX RAISED IN 0.25 MAX RECESS PAD.
 THIS INCLUDES RECYCLING CODE, CAVITY ID, VENDOR IDENTIFICATION, AND CUSTOMER MATERIAL NUMBER.
- f. VISUAL DEFECTS SHALL MEET COSMETIC STANDARD PS-45499-002 (Class B)
- g. LASER MARKING: TBD

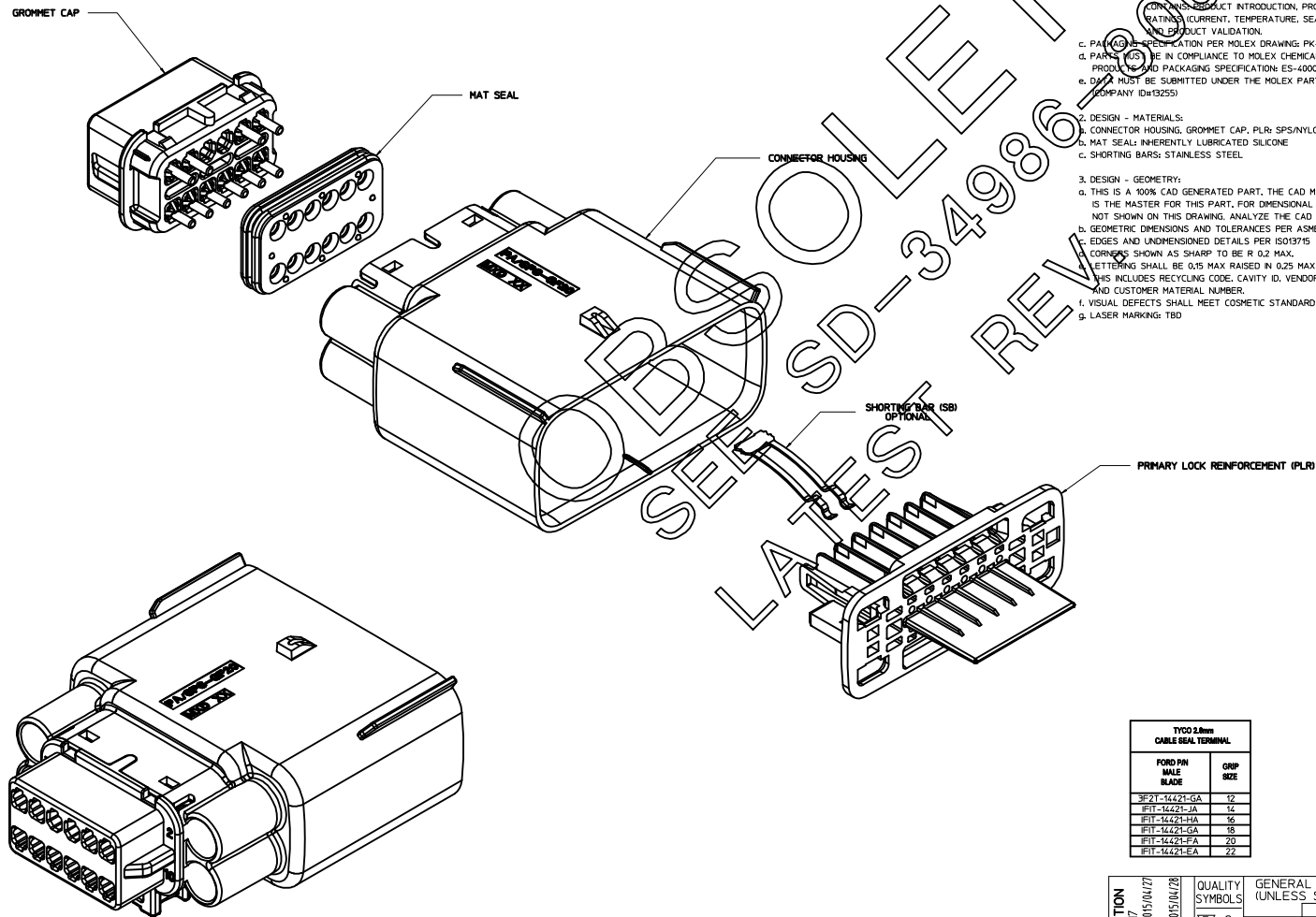

TYCO 2.8mm CABLE SEAL TERMINAL		
FORD P/N	MALE BLADE	GRP SIZE
3P2T-14421-GA	12	
3P2T-14421-MA	14	
3P2T-14421-HA	16	
3P2T-14421-GA	18	
3P2T-14421-FA	20	
3P2T-14421-EA	22	

INSPECTION NUMBER LOG
 LAST NUMBER USED:
 ADDED:
 REMOVED:

REV	DESCRIPTION	DATE
CJ	OBSOLETE DRAWING	
CH	ADD NEW P/N 33486-2047 THRU 33486-2103	
CG	UPDATED STATUS AND COMMENTS COLUMNS	
CF	ADD NEW P/N 33486-2045 33486-2046	
CE	ADD NEW P/N 33486-2039 33486-2040	
	33486-2041 33486-2044	
	33486-2043 33486-2044	
CC	ADD NEW P/N 33486-2036 33486-2037	
CB	ADD NEW P/N 33486-2033 33486-2034	
	33486-2035	
CA	RE-FORMATTED BOM TABLES	
B23	ADD NEW P/N 33486-2030 33486-2031	
	33486-2032	
B22	ADD NEW P/N 33486-2029	
B21	UPDATED DIMENSIONS TO MATCH MODEL	
BZ	ADD NEW P/N 33486-2027 33486-2028	
BY	ADD NEW P/N 33486-2025 33486-2026	
	ADD NEW P/N 33486-2019 33486-2020	
BX	33486-2021 33486-2022	
	33486-2023 33486-2024	
BW	REWORK	

ENTER DESCRIPTION EC NO: JAU2015-167 DRAWING P/N: 2015/01/17 APPROV: WJWSWY DATE: 2015/01/28	QUALITY SYMBOLS 0 4 PLACES ± --- ± --- 3 PLACES ± --- ± --- 2 PLACES ± 0.10 ± --- 1 PLACE ± 0.3 ± --- 0 PLACE ± ±	GENERAL TOLERANCES (UNLESS SPECIFIED) mm INCH ± 0.10 ± 0.004 ± 0.25 ± 0.010 ± 0.50 ± 0.020	DIMENSION STYLE MM ONLY DRAWN BY: JWSLEY DATE: 06-16-02 CHECKED BY: DATE: DGRIFITHS DATE: 07-09-02 APPROVED BY: DATE: WKOSHY DATE: 2010/12/08	DESIGN UNITS 4:1 METRIC THIRD ANGLE PROJECTION
	MATERIAL NO. SEE BOM DRAFT WHERE APPLICABLE WITHIN DIMENSIONS			DOCUMENT NO. SD-33486-161 SHEET NO. 9 OF 9
	THIS DRAWING CONTAINS INFORMATION THAT IS PROPRIETARY TO MOLEX, INCORPORATED AND SHOULD NOT BE USED WITHOUT WRITTEN PERMISSION			
	molex			

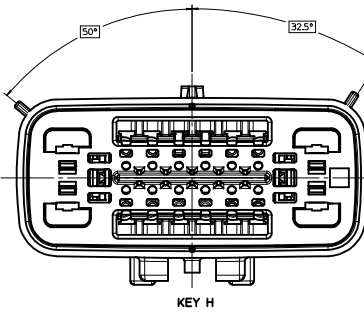
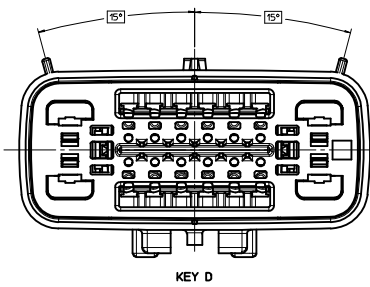
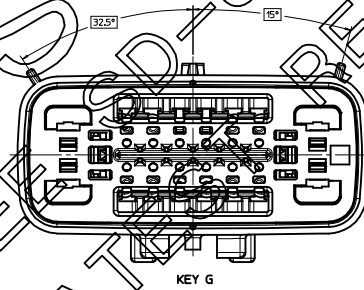
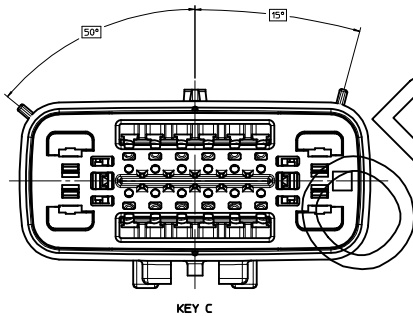
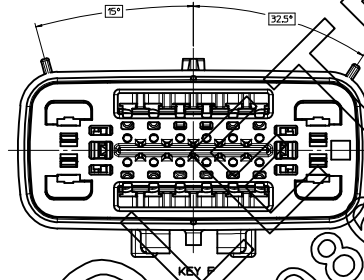
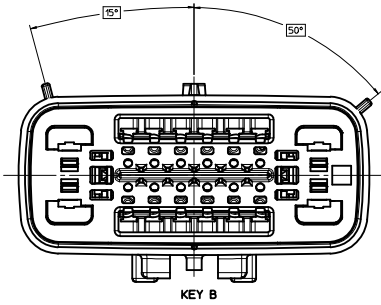
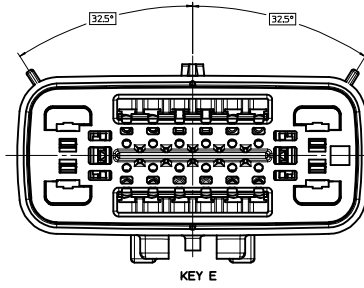
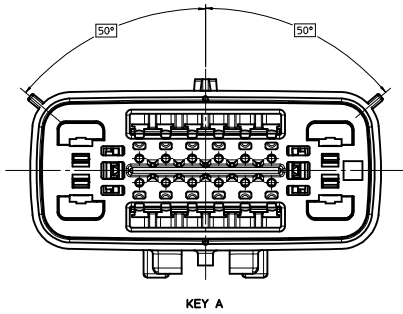

BSO 34986-8001
 LATEST REV.

ENTER DESCRIPTION EC NO: UAU205-467 DRAWN BY: JMW APPR: WOSHY DATE: 2015/04/28	QUALITY SYMBOLS ▽=0 ▽=1 ▽=2	GENERAL TOLERANCES (UNLESS SPECIFIED) mm INCH 4 PLACES ± --- ± --- 3 PLACES ± --- ± --- 2 PLACES ± 0.10 ± --- 1 PLACE ± 0.3 ± --- 0 PLACE ± ±	DIMENSION STYLE MM ONLY	SCALE 4:1	DESIGN UNITS METRIC	THIRD ANGLE PROJECTION	
	DRAWN BY: JMW DATE: 06-16-02	CHECKED BY: DGR DATE: 07-09-02	APPROVED BY: WKOSHY DATE: 2010/12/08	MATERIAL NO.	DOCUMENT NO.	TITLE MX150 16 WAY HYBRID BLADE SEALED ASSEMBLY	SHEET NO. 2 OF 9
	ANGULAR ± 3 °	DRAFT WHERE APPLICABLE MUST REMAIN WITHIN DIMENSIONS	SEE BOM	SD-33486-161	THIS DRAWING CONTAINS INFORMATION THAT IS PROPRIETARY TO MOLEX INCORPORATED AND SHOULD NOT BE USED WITHOUT WRITTEN PERMISSION	molex	9 8 7 6 5 4 3 2 1
	Ili frame_E_P_AM_T Rev. G 2012/01/11	23 22 21 20 19 18 17 16 15 14 13 12 11 10	9 8 7 6 5 4 3 2 1	9 8 7 6 5 4 3 2 1	9 8 7 6 5 4 3 2 1	9 8 7 6 5 4 3 2 1	9 8 7 6 5 4 3 2 1

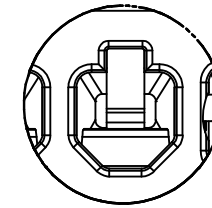
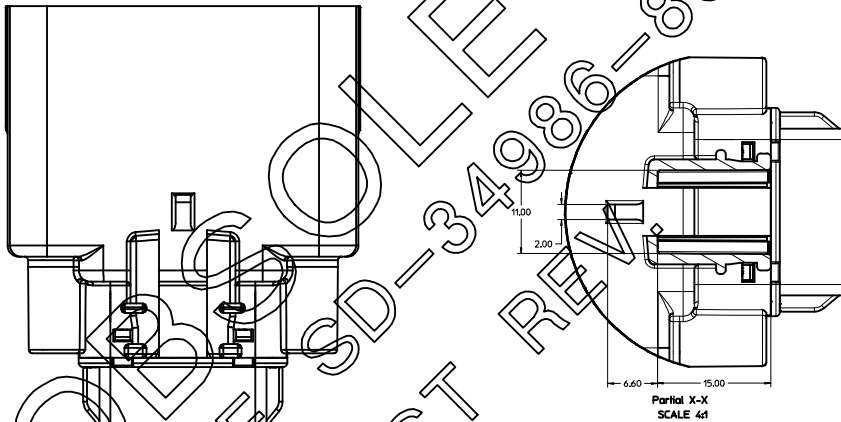
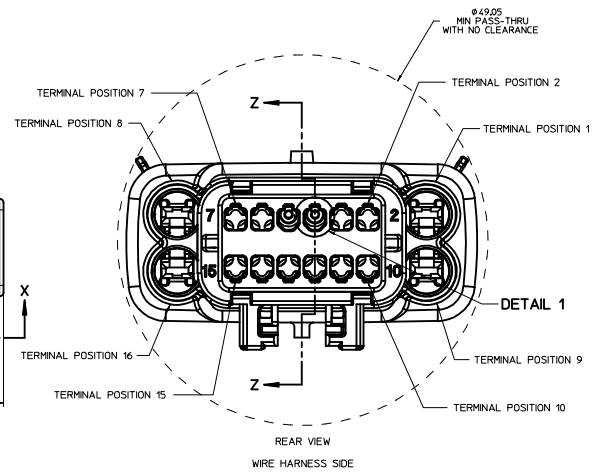
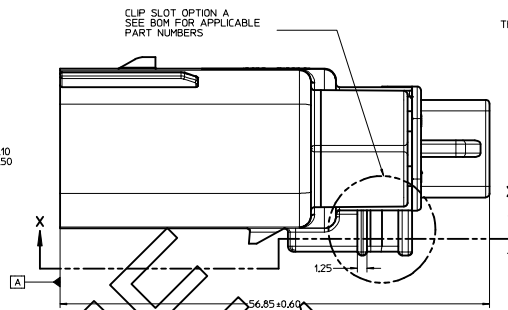
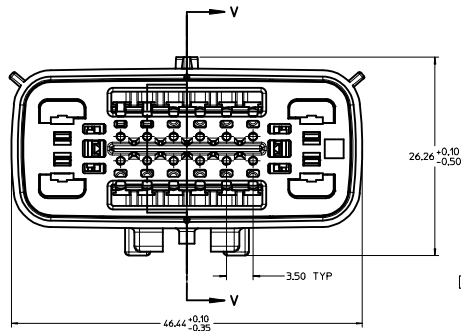
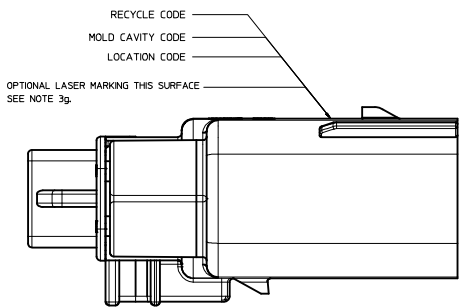

DETAIL 1
SCALE 20:1

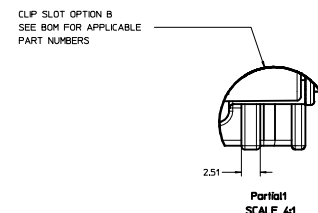
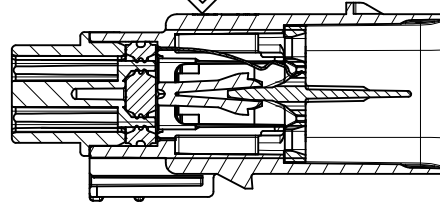
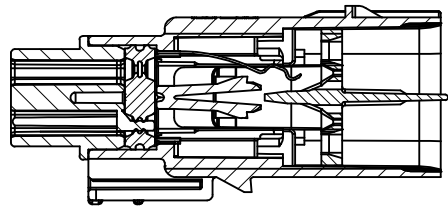

ENTER DESCRIPTION EC NO. UAU2015-167 DRAWING/PROFIT 2015/04/27 APPR. WOSNY REV. 2015/04/28	QUALITY SYMBOLS ▽=0 ▽=0 ▽=0	GENERAL TOLERANCES (UNLESS SPECIFIED) <table border="1"> <tr> <th></th> <th>mm</th> <th>INCH</th> </tr> <tr> <td>4 PLACES</td> <td>± 0.10</td> <td>± 0.004</td> </tr> <tr> <td>3 PLACES</td> <td>± 0.15</td> <td>± 0.006</td> </tr> <tr> <td>2 PLACES</td> <td>± 0.20</td> <td>± 0.008</td> </tr> <tr> <td>1 PLACE</td> <td>± 0.3</td> <td>± 0.012</td> </tr> <tr> <td>0 PLACE</td> <td>± 0.4</td> <td>± 0.016</td> </tr> </table>		mm	INCH	4 PLACES	± 0.10	± 0.004	3 PLACES	± 0.15	± 0.006	2 PLACES	± 0.20	± 0.008	1 PLACE	± 0.3	± 0.012	0 PLACE	± 0.4	± 0.016	DIMENSION STYLE MM ONLY DRAWN BY DATE JWESLEY 06-16-02 CHECKED BY DATE DGRIFITHS 07-09-02 APPROVED BY DATE WKOSHY 2010/12/08	SCALE 4:1 DESIGN UNITS METRIC THIRD ANGLE PROJECTION	MATERIAL NO. SEE BOM DOCUMENT NO. SD-33486-161 SHEET NO. 3 OF 9
		mm	INCH																				
	4 PLACES	± 0.10	± 0.004																				
	3 PLACES	± 0.15	± 0.006																				
2 PLACES	± 0.20	± 0.008																					
1 PLACE	± 0.3	± 0.012																					
0 PLACE	± 0.4	± 0.016																					
DRAFT WHERE APPLICABLE MUST REMAIN WITHIN DIMENSIONS																							
THIS DRAWING CONTAINS INFORMATION THAT IS PROPRIETARY TO MOLEX INCORPORATED AND SHOULD NOT BE USED WITHOUT WRITTEN PERMISSION																							
moxlex																							

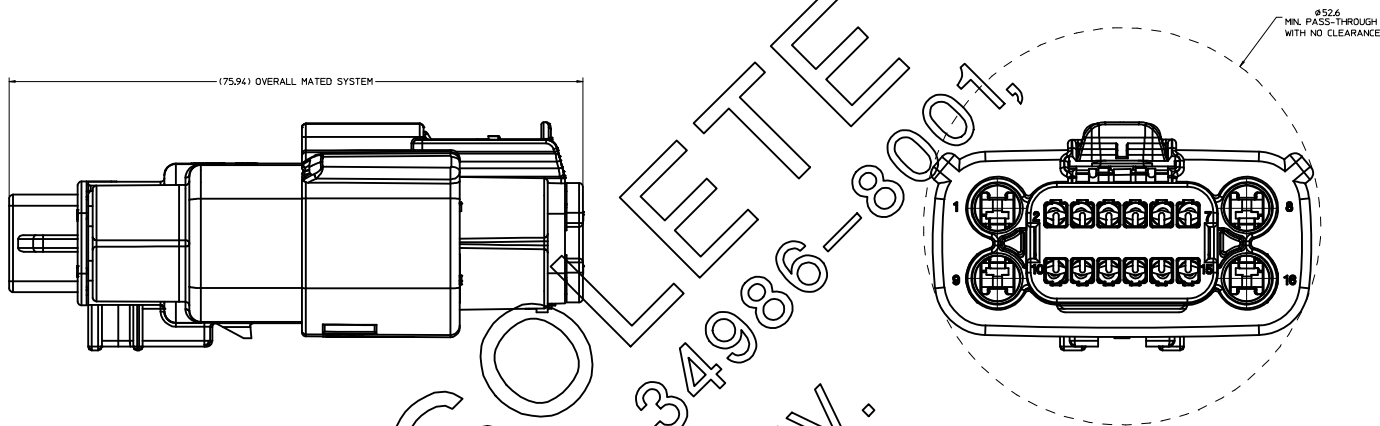

OBSOLETE
SEE SD-34986-8001
LATEST REV.

ENTER DESCRIPTION EC NO: 0A0205-167 DRAWN BY: JMWESLEY 2015/04/27 CHECKED BY: DGRIFITHS APPR: WKOSHY 2015/04/28 REV:	QUALITY SYMBOLS	4 PLACES ± 0.15 ± 0.006 3 PLACES ± 0.20 ± 0.008 2 PLACES ± 0.30 ± 0.012 1 PLACE ± 0.50 ± 0.020 0 PLACE ± 0.75 ± 0.030	GENERAL TOLERANCES (UNLESS SPECIFIED) mm INCH ± 0.15 ± 0.006 ± 0.20 ± 0.008 ± 0.30 ± 0.012 ± 0.50 ± 0.020 ± 0.75 ± 0.030	DIMENSION STYLE MM ONLY DRAWN BY: JMWESLEY DATE: 06-16-02 CHECKED BY: DGRIFITHS DATE: 07-09-02 APPROVED BY: WKOSHY DATE: 2010/12/08	SCALE: 4:1 DESIGN UNITS: METRIC THIRD ANGLE PROJECTION	MX150 16 WAY HYBRID BLADE SEALED ASSEMBLY molex	MATERIAL NO: DOCUMENT NO: SD-33486-161 SHEET NO: 4 OF 9
	ANGULAR ± 3°		DRAFT WHERE APPLICABLE MUST REMAIN WITHIN DIMENSIONS		SEE BOM		THIS DRAWING CONTAINS INFORMATION THAT IS PROPRIETARY TO MOLEX INCORPORATED AND SHOULD NOT BE USED WITHOUT WRITTEN PERMISSION
	DRAFT WHERE APPLICABLE MUST REMAIN WITHIN DIMENSIONS		SEE BOM		SEE BOM		
	DRAFT WHERE APPLICABLE MUST REMAIN WITHIN DIMENSIONS		SEE BOM		SEE BOM		

ASSEMBLY DESCRIPTION	ASSEMBLY PART NUMBER	A	B	C	D	E	F	G	H	A	C	D	GCS	SB1	SB2	SB3	SB4	SB5	SB6	SB7	SB8	SB9	SB10	SB11	SB12	SB13	SB14	SB15	STATUS	COMMENTS	
KEY A, BLACK	33486-1845	A											GCS																		
KEY A, BLACK	33486-1844	A											GCS																		
KEY A, BLACK	33486-1843	A											GCS																		
KEY A, BLACK	33486-1842	A											GCS																		
KEY A, BLACK	33486-1841	A											GCS																		
KEY H, W/ S.B., YELLOW	33486-1840	A											GCS																		
KEY E, BLACK	33486-1839	A											GCS																		
KEY E, BLACK	33486-1838	A											GCS																		
KEY A, BLACK	33486-1837	A											GCS																		
KEY B, LIGHT GRAY	33486-1836	B											GCS																		
KEY B, LIGHT GRAY	33486-1835	B											GCS																		
KEY B, LIGHT GRAY	33486-1832	B											GCS																		
KEY A, BLACK	33486-1833	A											GCS																		
KEY A, BLACK	33486-1832	A											GCS																		
KEY E, W/ S.B., BLACK	33486-1831	A											GCS	SB1																	
KEY A, BLACK	33486-1830	A											GCS																		
KEY A, BLACK	33486-1829	A											GCS																		
KEY A, BLACK	33486-1828	A											GCS																		
KEY A, BLACK	33486-1827	A											GCS																		
KEY A, BLACK	33486-1826	A											GCS																		
KEY A, BLACK	33486-1825	A											GCS																		
KEY E, W/ S.B., BLACK	33486-1824	A											GCS	SB3																	
KEY A, BLACK	33486-1823	A											GCS																		
KEY A, BLACK	33486-1822	A											GCS																		
KEY A, BLACK	33486-1821	A											GCS																		
KEY A, BLACK	33486-1820	A											GCS																		
KEY A, BLACK	33486-1819	A											GCS																		
KEY A, BLACK	33486-1818	A											GCS																		
KEY A, BLACK	33486-1817	A											GCS																		
KEY A, BLACK	33486-1816	A											GCS																		
KEY A, BLACK	33486-1815	A											GCS																		
KEY A, BLACK	33486-1814	A											GCS																		
KEY A, BLACK	33486-1813	A											GCS																		
KEY A, BLACK	33486-1812	A											GCS																		
KEY B, LIGHT GRAY	33486-1811	B											GCS																		
KEY B, LIGHT GRAY	33486-1810	B											GCS																		
KEY B, LIGHT GRAY	33486-1809	B											GCS																		
KEY A, YELLOW	33486-1808	A											GCS																		
KEY A, BLACK	33486-1807	A											GCS																		
KEY A, BLACK	33486-1806	A											GCS																		
KEY A, BLACK	33486-1805	A											GCS																		
KEY A, BLACK	33486-1804	A											GCS																		
KEY A, BLACK	33486-1803	A											GCS																		
KEY A, BLACK	33486-1802	A											GCS																		
KEY A, BLACK	33486-1801	A											GCS																		
KEY A, BLACK	33486-1799	A											GCS																		
KEY A, BLACK	33486-1798	A											GCS																		
KEY A, BLACK	33486-1797	A											GCS																		
KEY A, BLACK	33486-1796	A											GCS																		
KEY A, BLACK	33486-1795	A											GCS																		
KEY A, BLACK	33486-1794	A											GCS																		
KEY A, BLACK	33486-1793	A											GCS																		
KEY A, BLACK	33486-1792	A											GCS																		
KEY A, BLACK	33486-1791	A											GCS																		
KEY A, BLACK	33486-1790	A											GCS																		
KEY A, BLACK	33486-1789	A											GCS																		
KEY A, BLACK	33486-1788	A											GCS																		
KEY A, BLACK	33486-1787	A											GCS																		
KEY A, BLACK	33486-1786	A											GCS																		
KEY A, BLACK	33486-1785	A											GCS																		
KEY A, BLACK	33486-1784	A											GCS																		
KEY A, BLACK	33486-1783	A											GCS																		
KEY E, W/ S.B., BLACK	33486-1782	A											GCS	SB4																	
KEY A, BLACK	33486-1781	A											GCS																		
KEY A, BLACK	33486-1780	A											GCS																		
KEY A, BLACK	33486-1779	A											GCS																		
KEY A, BLACK	33486-1778	A											GCS																		
KEY A, BLACK	33486-1777	A											GCS																		
KEY A, BLACK	33486-1776	A											GCS																		
KEY H, W/ S.B., YELLOW	33486-1775	A											GCS	SB2																	
KEY H, W/ S.B., YELLOW	33486-1774	A											GCS	SB2																	
KEY H, W/ S.B., YELLOW	33486-1773	A											GCS	SB2																	
KEY H, W/ S.B., YELLOW	33486-1772	A											GCS	SB2																	
KEY A, BLACK	33486-1771	A											GCS																		
KEY A, BLACK	33486-1770	A											GCS																		
KEY A, BLACK	33486-1769	A											GCS																		
KEY A, BLACK	33486-1768	A											GCS																		
KEY H, W/ S.B., YELLOW	33486-1767	A											GCS	SB1																	
KEY H, W/ S.B., YELLOW	33486-1766	A											GCS	SB1																	
KEY F, W/ S.B., LIGHT GRAY	33486-1765	A																													

KEY	DESCRIPTION	ASSEMBLY PART NUMBER	QTY	STATUS	COMMENTS
KEY H, YELLOW	33486-2103	A			
KEY A, BLACK	33486-2102	A			
KEY A, BLACK	33486-2101	A			
KEY B, LIGHT GRAY	33486-2100	B			
KEY A, YELLOW	33486-2099	A			
KEY A, YELLOW	33486-2098	A			
KEY A, BLACK	33486-2097	A			
KEY A, BLACK	33486-2096	A			
KEY A, BLACK	33486-2095	A			
KEY A, BLACK	33486-2094	A			
KEY A, BLACK	33486-2093	A			
KEY B, LIGHT GRAY	33486-2092	B			
KEY B, LIGHT GRAY	33486-2091	B			
KEY A, BLACK	33486-2090	A			
KEY A, BLACK	33486-2089	A			
KEY A, BLACK	33486-2088	A			
KEY B, LIGHT GRAY	33486-2087	B			
KEY A, BLACK	33486-2086	A			
KEY A, BLACK	33486-2085	A			
KEY A, BLACK	33486-2084	A			
KEY A, BLACK	33486-2083	A			
KEY A, BLACK	33486-2082	A			
KEY A, BLACK	33486-2081	A			
KEY B, LIGHT GRAY	33486-2080	B			
KEY B, LIGHT GRAY	33486-2079	B			
KEY A, BLACK	33486-2078	A			
KEY A, BLACK	33486-2077	A			
KEY A, BLACK	33486-2076	A			
KEY A, BLACK	33486-2075	A			
KEY F, W/ SB, LIGHT GRAY	33486-2074	F			
KEY F, W/ SB, LIGHT GRAY	33486-2073	F			
KEY A, BLACK	33486-2072	A			
KEY A, BLACK	33486-2071	A			
KEY A, BLACK	33486-2070	A			
KEY A, BLACK	33486-2069	A			
KEY A, BLACK	33486-2068	A			
KEY A, BLACK	33486-2067	A			
KEY F, W/ SB, LIGHT GRAY	33486-2066	F			
KEY F, LIGHT GRAY	33486-2065	F			
KEY A, BLACK	33486-2064	A			
KEY F, W/ SB, LIGHT GRAY	33486-2063	F			
KEY F, W/ SB, LIGHT GRAY	33486-2062	F			
KEY A, BLACK	33486-2061	A			
KEY A, BLACK	33486-2060	A			
KEY B, LIGHT GRAY	33486-2059	B			
KEY B, LIGHT GRAY	33486-2058	B			
KEY A, BLACK	33486-2057	A			
KEY A, BLACK	33486-2056	A			
KEY A, BLACK	33486-2055	A			
KEY A, BLACK	33486-2054	A			
KEY A, BLACK	33486-2053	A			
KEY A, BLACK	33486-2052	A			
KEY A, BLACK	33486-2051	A			
KEY A, BLACK	33486-2050	A			
KEY A, BLACK	33486-2049	A			
KEY A, BLACK	33486-2048	A			
KEY A, BLACK	33486-2047	A			
KEY F, W/ SB, LIGHT GRAY	33486-2046	F			
KEY F, LIGHT GRAY	33486-2045	F			
KEY A, BLACK	33486-2044	A			
KEY A, BLACK	33486-2043	A			
KEY A, BLACK	33486-2042	A			
KEY A, BLACK	33486-2041	A			
KEY A, BLACK	33486-2040	A			
KEY A, BLACK	33486-2039	A			
KEY A, BLACK	33486-2037	A			
KEY A, BLACK	33486-2036	A			
KEY A, BLACK	33486-2035	A			
KEY A, BLACK	33486-2034	A			
KEY A, BLACK	33486-2033	A			
KEY B, LIGHT GRAY	33486-2032	B			
KEY B, LIGHT GRAY	33486-2031	B			
KEY B, LIGHT GRAY	33486-2030	B			
KEY A, BLACK	33486-2029	A			
KEY A, BLACK	33486-2028	A			
KEY A, BLACK	33486-2027	A			
KEY A, BLACK	33486-2026	A			
KEY A, BLACK	33486-2025	A			
KEY A, BLACK	33486-2024	A			
KEY A, BLACK	33486-2023	A			
KEY A, BLACK	33486-2022	A			
KEY A, BLACK	33486-2021	A			
KEY A, BLACK	33486-2020	A			
KEY A, BLACK	33486-2019	A			
KEY A, BLACK	33486-2018	A			
KEY B, LIGHT GRAY	33486-2017	B			
KEY B, LIGHT GRAY	33486-2016	B			
KEY B, LIGHT GRAY	33486-2015	B			
KEY A, BLACK	33486-2014	A			
KEY B, LIGHT GRAY	33486-2013	B			
KEY A, BLACK	33486-2012	A			
KEY A, BLACK	33486-2011	A			
KEY H, YELLOW	33486-2010	H			

PLANNED OBSOLESCENCE
SEE DRAWING SD-34986-8001
FOR REPLACEMENT P/N

NEW SERIES NUMBER IS 34986
SAME SUFFIX

REPLACEMENT PART
SEE DRAWING SD-34986-8001
REV. 01

ABBREVIATION	COMPONENT
A	HOUSING KEY A
B	HOUSING KEY B
C	HOUSING KEY C
D	HOUSING KEY D
E	HOUSING KEY E
F	HOUSING KEY F
G	HOUSING KEY G
H	HOUSING KEY H
GCS	STANDARD GROMMET CAP
SB	SHORTING BAR

CAVITY WITH AN "X" INDICATES BLOCKED TERMINAL POSITION
CAVITY WITHOUT AN "X" INDICATES OPEN TERMINAL POSITION
CAVITY WITH AN "SB" INDICATES SHORTING BAR CAVITY

PLR	NATURAL	SPS/NYLON GF20
MAT SEAL	ROYAL BLUE	INHERENTLY LUBRICATED SILICONE
SHORTING BAR	GOLD PL	30100 STAINLESS STEEL
SHORTING BAR GROMMET CAP 5	BLACK	SPS/NYLON GF20
SHORTING BAR GROMMET CAP 1	BLACK	SPS/NYLON GF20
SHORTING BAR GROMMET CAP 3	BLACK	SPS/NYLON GF20
SHORTING BAR GROMMET CAP 2	BLACK	SPS/NYLON GF20
SHORTING BAR GROMMET CAP 1	BLACK	SPS/NYLON GF20
STANDARD GROMMET CAP	BLACK	SPS/NYLON GF20
HOUSING KEYING OPTION D	ST GRAY	SPS/NYLON GF20
HOUSING KEYING OPTION C	DARK GRAY	SPS/NYLON GF20
HOUSING KEYING OPTION A	YELLOW	SPS/NYLON GF20
HOUSING KEYING OPTION H	YELLOW	SPS/NYLON GF20
HOUSING KEYING OPTION G	BROWN	SPS/NYLON GF20
HOUSING KEYING OPTION F	BROWN	SPS/NYLON GF20
HOUSING KEYING OPTION E	BLACK	SPS/NYLON GF20
HOUSING KEYING OPTION D	GREEN	SPS/NYLON GF20
HOUSING KEYING OPTION C	BROWN	SPS/NYLON GF20
HOUSING KEYING OPTION B	LIGHT GRAY	SPS/NYLON GF20
HOUSING KEYING OPTION A	BLACK	SPS/NYLON GF20

ENTER DESCRIPTION EC NO: 040205-607 DRAWN BY: JMWESLEY CHECKED BY: DGRIFITHS APPROVED BY: VKDUSHY DATE: 2015/04/27 APPR: WOSHY REV: 2015/04/28	QUALITY SYMBOLS 0.05 0.1 0.2	GENERAL TOLERANCES (UNLESS SPECIFIED) mm INCH 4 PLACES ± 0.15 ± 0.006 3 PLACES ± 0.10 ± 0.004 2 PLACES ± 0.10 ± 0.004 1 PLACE ± 0.3 ± 0.012 0 PLACE ± 0.3 ± 0.012	DIMENSION STYLE MM ONLY DRAWN BY: JMWESLEY CHECKED BY: DGRIFITHS APPROVED BY: VKDUSHY DATE: 06-16-02 DATE: 07-09-02 DATE: 2010/12/08	SCALE 2:1 DESIGN UNITS METRIC THIRD ANGLE PROJECTION	DOCUMENT NO. SD-33486-161 SHEET NO. 9 OF 9
	DRAFT WHERE APPLICABLE MUST REMAIN WITHIN DIMENSIONS				
	THIS DRAWING CONTAINS INFORMATION THAT IS PROPRIETARY TO MOLEX INCORPORATED AND SHOULD NOT BE USED WITHOUT WRITTEN PERMISSION				
	MATERIAL NO. SD-33486-161				