

60V, 250mA Linear Charger with Low Quiescent Current

FEATURES

- **Wide Input Voltage Range: 2.7V to 60V**
- **Adjustable Battery Voltage: 1.2V to 60V**
- **Adjustable Charge Current: 10mA to 250mA**
- **Low Quiescent Current While Charging: $I_{IN} = 4\mu A$**
- **Ultralow Battery Drain When Shutdown or Charged:**
 - $I_{BAT} < 0.01\mu A$
- **Auto Recharge**
- **Input Voltage Regulation for High Impedance Sources**
- Thermal Regulation Maximizes Output Current without Overheating
- Constant Voltage Feedback with $\pm 0.5\%$ Accuracy
- NTC Thermistor Input for Temperature Qualified Charging
- Adjustable Safety Timer
- Charging Status Indication
- Thermally Enhanced 10-Lead (3mm × 3mm) DFN Package
- AEC-Q100 Qualified for Automotive Applications

APPLICATIONS

- Embedded Automotive and Industrial
- Backup Battery Charging from Another Battery
- Energy Harvesting Charger
- Thin Film Battery Products

DESCRIPTION

The **LTC®4079** is a low quiescent current, high voltage linear charger for most battery chemistry types including Li-Ion/Polymer, LiFePO₄, Lead-Acid or NiMH battery stacks up to 60V. The maximum charge current is adjustable from 10mA to 250mA with an external resistor. The battery charge voltage is set using an external resistor divider.

With an integrated power device, current sensing and reverse current protection, a complete charging solution using the LTC4079 requires very few external components. Thermal regulation ensures maximum charge current up to the specified limit without the risk of overheating. Charging can be terminated by either C/10 or adjustable timer.

Input voltage regulation reduces charge current when the input voltage falls to an adjustable level or the battery voltage, making it well suited for energy harvesting applications. Other features include temperature qualified charging, bad battery detection, automatic recharge with sampled feedback in standby for negligible battery drain, and an open-drain \overline{CHRG} status output. The device is offered in a compact, thermally enhanced 10-lead (3mm × 3mm) DFN package.

All registered trademarks and trademarks are the property of their respective owners.

TYPICAL APPLICATION

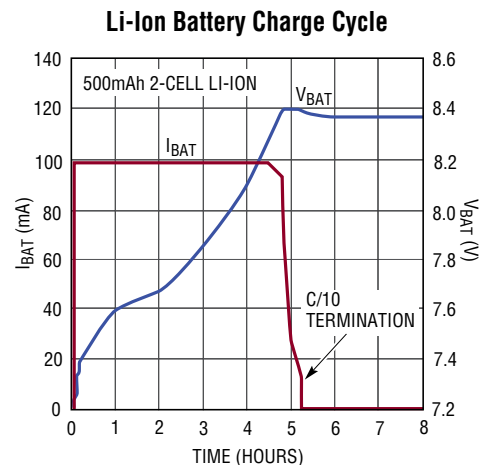
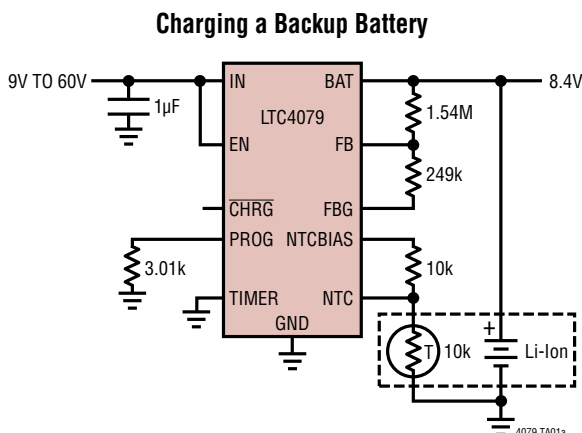

LTC4079

ABSOLUTE MAXIMUM RATINGS

(Notes 1, 2)

IN, BAT, EN, $\overline{\text{CHRG}}$, FB, FBG Voltage.....	-0.3V to 62V
PROG TIMER Voltage.....	3V
BAT Current.....	-400mA
PROG Current.....	-1.6mA
FBG Current.....	2mA
$\overline{\text{CHRG}}$ Current.....	2mA
Operating Junction Temperature Range (Notes 3, 5).....	-40 to 125°C
Storage Temperature Range.....	-65 to 150°C

PIN CONFIGURATION

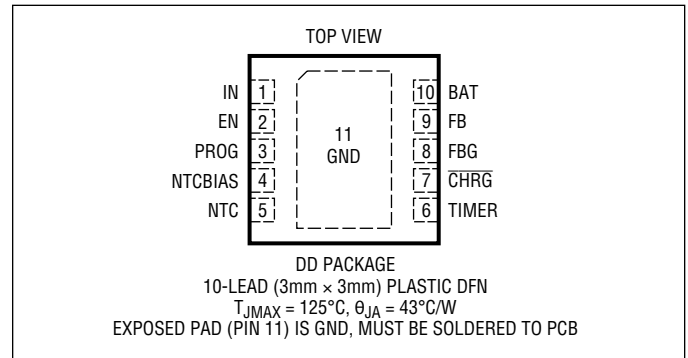

ORDER INFORMATION

LEAD FREE FINISH	TAPE AND REEL	PART MARKING*	PACKAGE DESCRIPTION	TEMPERATURE RANGE
LTC4079EDD#PBF	LTC4079EDD#TRPBF	LGNQ	10-Lead (3mm × 3mm) Plastic DFN	-40°C to 125°C
LTC4079IDD#PBF	LTC4079IDD#TRPBF	LGNQ	10-Lead (3mm × 3mm) Plastic DFN	-40°C to 125°C

AUTOMOTIVE PRODUCTS**

LTC4079EDD#WPBF	LTC4079EDD#WTRPBF	LGNQ	10-Lead (3mm × 3mm) Plastic DFN	-40°C to 125°C
LTC4079IDD#WPBF	LTC4079IDD#WTRPBF	LGNQ	10-Lead (3mm × 3mm) Plastic DFN	-40°C to 125°C

Contact the factory for parts specified with wider operating temperature ranges. *The temperature grade is identified by a label on the shipping container.

Tape and reel specifications. Some packages are available in 500 unit reels through designated sales channels with #TRMPBF suffix.

**Versions of this part are available with controlled manufacturing to support the quality and reliability requirements of automotive applications. These models are designated with a #W suffix. Only the automotive grade products shown are available for use in automotive applications. Contact your local Analog Devices account representative for specific product ordering information and to obtain the specific Automotive Reliability reports for these models.

ELECTRICAL CHARACTERISTICS

The ● denotes the specifications which apply over the specified operating junction temperature range, otherwise specifications are at $T_A = 25^\circ\text{C}$ (Notes 2, 3). $V_{IN} = 12\text{V}$, $V_{BAT} = 7.4\text{V}$, $V_{FB} = 1.057\text{V}$, $V_{EN} = 12\text{V}$, $R_{PROG} = 3\text{k}$ (100mA charge current) unless otherwise specified.

SYMBOL	PARAMETER	CONDITIONS	MIN	TYP	MAX	UNITS
V_{IN}	Operating Supply Voltage		● 2.7		60	V
V_{BAT}	Battery Voltage Range		●		60	V
V_{UVLO}	V_{IN} Undervoltage Lockout	V_{IN} Rising Hysteresis	●	2.55 140	2.7	V mV
V_{DUVLO}	Differential Undervoltage Lockout	$V_{IN}-V_{BAT}$ Rising Hysteresis	●	-20 15 80	50	mV mV
V_{DVREG}	Differential Voltage Regulation	Minimum $V_{IN}-V_{BAT}$ for Charge Current	●	120	160 200	mV
$I_{Q(IN)}$	Input Supply Quiescent Current	Charging (Note 4) Charging Terminated ($V_{FB} = 1.210\text{V}$) Shutdown ($EN = 0$)	● ●	4 2 0.2	9 4 0.6	μA μA μA
$I_{Q(BAT)}$	Battery Drain Current	Charging Terminated ($V_{FB} = 1.210\text{V}$) Shutdown ($EN = 0$) $V_{IN} = 0$ or IN open		0.01 0.00 0.05	0.2 0.2 0.2	μA μA μA

Charging Functions

$V_{FB(CHG)}$	Feedback Pin Regulation Voltage in Constant-Voltage Charge Mode		●	1.165 1.156	1.170 1.170	1.175 1.184	V V
	PROG Pin Regulated Voltage	Constant-Current Mode			1.190		V
	Ratio of BAT Current to PROG Pin Current				250		mA/mA
I_{CHG}	Battery Charge Current in Constant-Current Mode (Note 5)	$R_{PROG} = 1.2\text{k}$ $R_{PROG} = 3\text{k}$ $R_{PROG} = 30\text{k}$	● ● ●	236 93 8.5	248 99 10	260 105 11.5	mA mA mA
$I_{TERMINATE}$	Charging Termination Threshold	$R_{PROG} = 1.2\text{k}$ $R_{PROG} = 3\text{k}$ $R_{PROG} = 30\text{k}$	● ● ●	22 8.2 0.7	25 10 1	28 11.8 1.3	mA mA mA
$t_{TERMINATE}$	Deglitch Filter on C/10 Charge Termination	I_{CHG} Drops Below Termination Threshold		5	9	13	ms
t_{TIMER}	Safety Timer Accuracy			-10		10	%
V_{RECHRG}	Recharge Threshold Voltage of FB Pin	Relative to $V_{FB(CHG)}$ with V_{FB} Falling		96.9	97.6	98.3	%
$V_{FB(LOWBAT)}$	Low Battery Threshold	V_{FB} for Low Battery Detection	●	0.780	0.800	0.820	V
	Low Battery Time Out (Percentage of Safety Timer)	Charging with $V_{FB} < V_{FB(LOWBAT)}$			18		%
R_{ON}	Resistance of the Charge Path				5		Ω
I_{FB}	Feedback Pin Leakage	$V_{FB} = 1.170\text{V}$ (in Regulation) $V_{FB} = 8.4\text{V}$ (in Shutdown)	● ●		0.1 0.1	20 100	nA nA
I_{FBG}	Feedback Ground Pin Leakage	$V_{FBG} = 8.4\text{V}$, $EN = 0$	●		0.1	100	nA
R_{FBG}	Switch Resistance from FBG Pin to GND				160		Ω
	Die Temperature (T_J) at Thermal Regulation				118		$^\circ\text{C}$

ELECTRICAL CHARACTERISTICS

The ● denotes the specifications which apply over the specified operating junction temperature range, otherwise specifications are at $T_A = 25^\circ\text{C}$ (Notes 2, 3). $V_{IN} = 12\text{V}$, $V_{BAT} = 7.4\text{V}$, $V_{FB} = 1.057\text{V}$, $V_{EN} = 12\text{V}$, $R_{PROG} = 3\text{k}$ (100mA charge current) unless otherwise specified.

SYMBOL	PARAMETER	CONDITIONS		MIN	TYP	MAX	UNITS
NTC Temp Monitor							
V_{COLD}	Low Temp. Fault NTC Threshold Voltage	$V_{NTC}/V_{NTCBIAS}$	●	72.3	73.8	75.3	%
V_{HOT}	High Temp. Fault NTC Threshold Voltage	$V_{NTC}/V_{NTCBIAS}$	●	35.6	36.6	37.6	%
$V_{NTC(DIS)}$	NTC Disable Voltage Threshold	V_{NTC}	●	60	80	100	mV
	Pulsed NTCBIAS Voltage	20k from NTCBIAS to Ground			4		V
	NTCBIAS Period				3		Sec
	NTCBIAS Pulse Width				210		μs
	NTC Input Leakage Current	$V_{NTC} = V_{NTCBIAS}$	●		0.1	100	nA
Enable Input (EN)							
$V_{EN(SD)}$	Shutdown Threshold	V_{EN} Falling Hysteresis	●	0.400	0.750 55	1.100	V mV
$V_{EN(REG)}$	Enable Pin Regulation Voltage	Minimum V_{EN} for Charge Current	●	1.170	1.190	1.210	V
	Enable Pin Leakage Current When Pulled High	$V_{EN} = 60\text{V}$	●		0	20	nA
Status Outputs (CHRG)							
	Output Low Voltage	1mA Into the Open-Drain Output	●		0.16	0.4	V
	Output Leakage Current	$V_{CHRG} = 60\text{V}$, $V_{EN} = 0\text{V}$	●		0.1	100	nA

Note 1: Stresses beyond those listed under Absolute Maximum Ratings may cause permanent damage to the device. Exposure to any Absolute Maximum Rating condition for extended periods may affect device reliability and lifetime.

Note 2: Unless otherwise specified, current into a pin is positive and current out of a pin is negative.

Note 3: The LTC4079 is tested under pulsed load conditions such that $T_J \approx T_A$. The LTC4079E is guaranteed to meet performance specifications from 0°C to 125°C junction temperature. Specifications over the -40°C to 125°C operating junction temperature range are assured by design, characterization and correlation with statistical process controls. The LTC4079I is guaranteed over the full -40°C to 125°C operating junction temperature range. Note that the maximum ambient temperature consistent with these specifications is determined by specific operating conditions in conjunction with board layout, the rated package thermal impedance and other environmental factors.

Note 4: BAT pin charge current, PROG pin and feedback divider currents are excluded from supply quiescent current.

Note 5: Charge current is reduced by thermal regulation as the junction temperature rises above T_{LIM} (118°C).

TYPICAL PERFORMANCE CHARACTERISTICS $V_{IN} = 12V$, $T_A = 25^\circ C$ unless otherwise noted.

Regulated Feedback Voltage vs Temperature

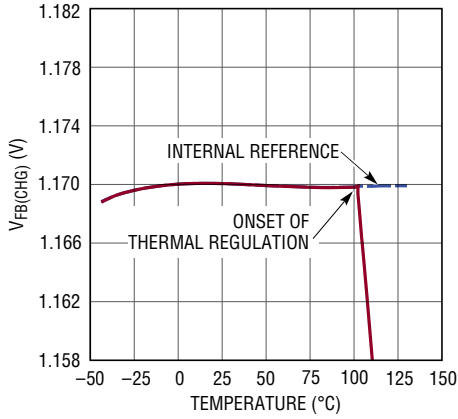

4079 G01

Regulated Feedback Voltage vs V_{IN}

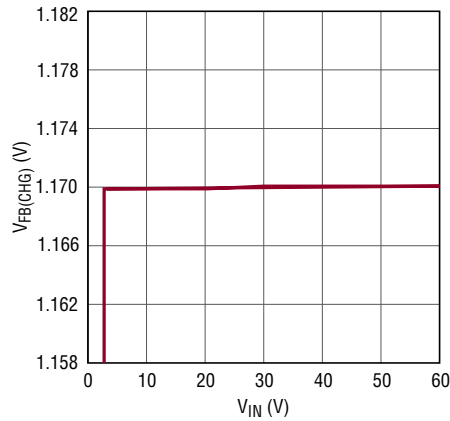

4079 G02

Load Regulation of Regulated Feedback Voltage

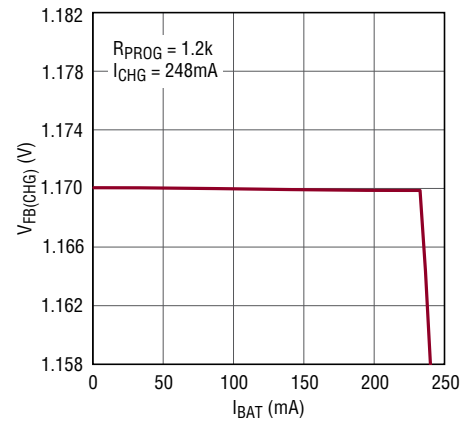

4079 G03

Input Supply Quiescent Current vs Temperature

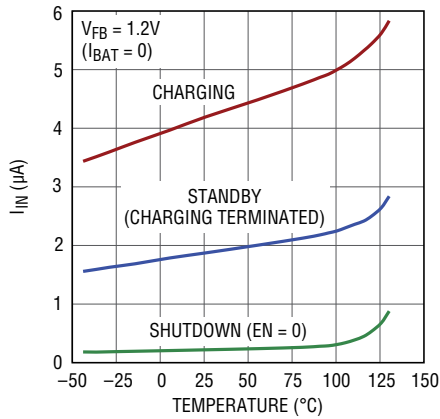

4079 G04

Input Supply Quiescent Current vs Supply Voltage

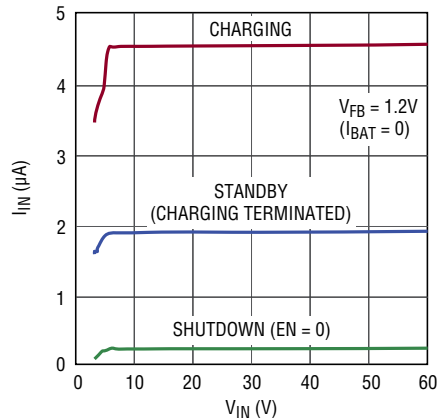

4079 G05

Battery Quiescent Current vs Temperature

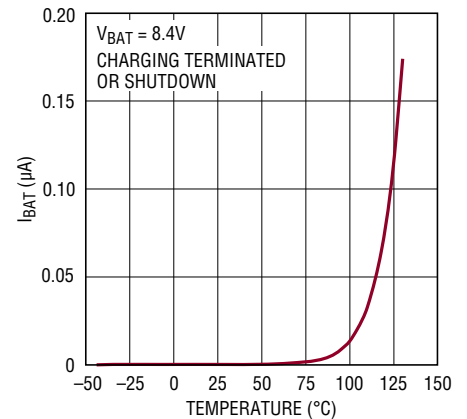

4079 G06

Battery Quiescent Current vs Battery Voltage

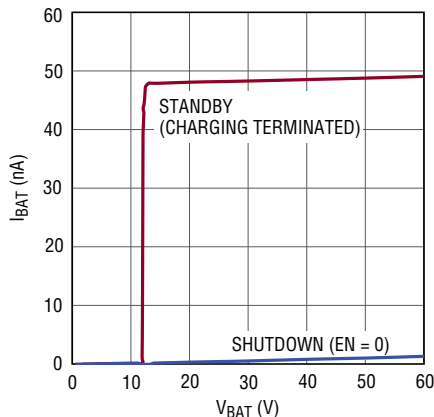

4079 G07

Battery Charge Current vs Battery Voltage

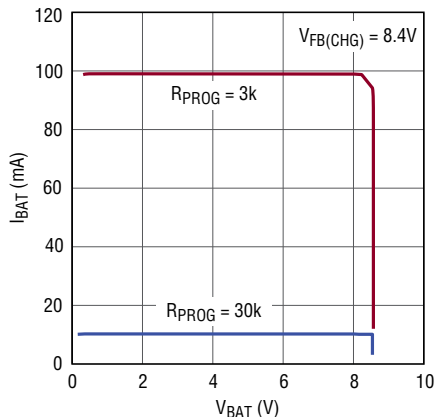

4079 G08

Battery Charge Current vs Temperature

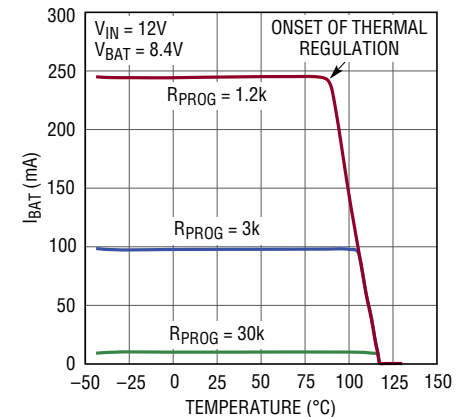

4079 G09

TYPICAL PERFORMANCE CHARACTERISTICS $V_{IN} = 12V$, $T_A = 25^\circ C$ unless otherwise noted.

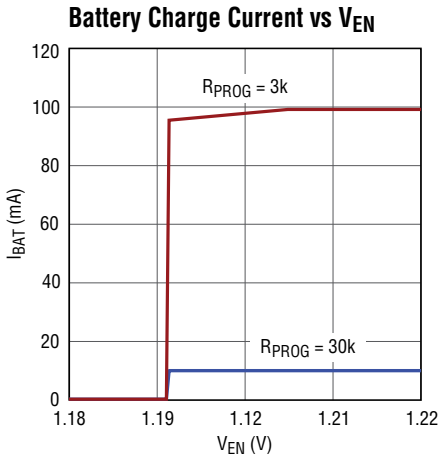

4079 G10

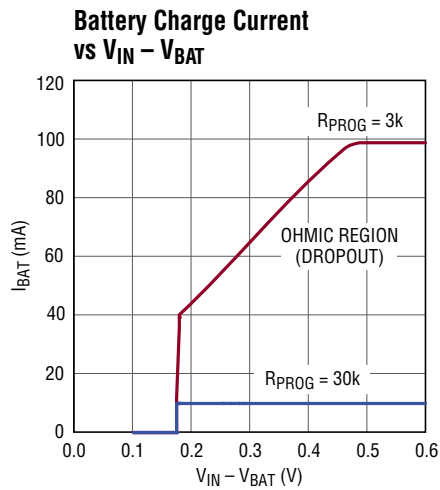

4079 G11

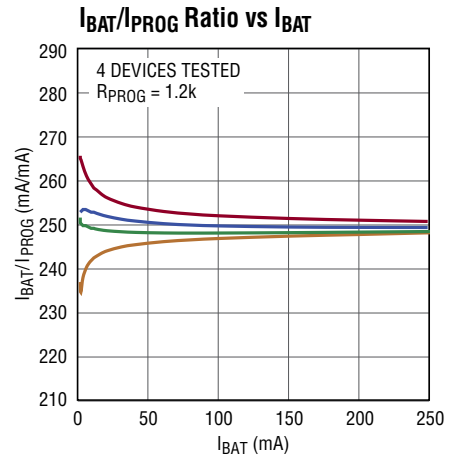

4079 G12

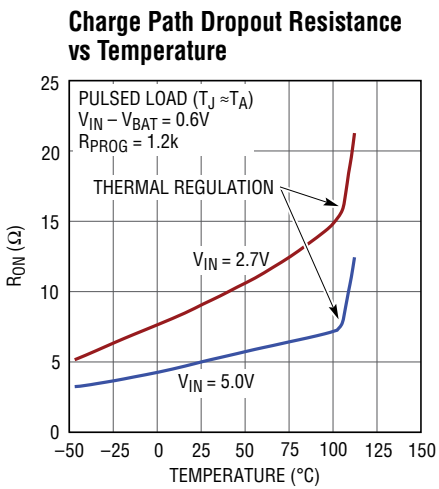

4079 G13

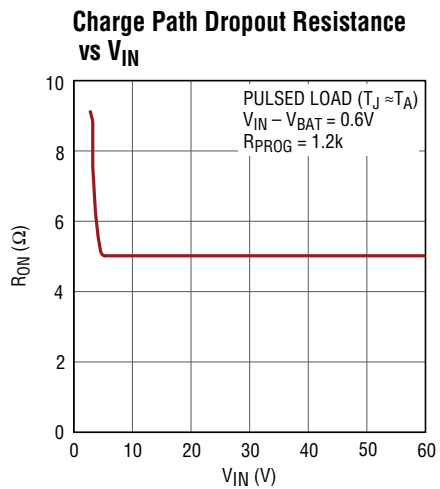

4079 G14

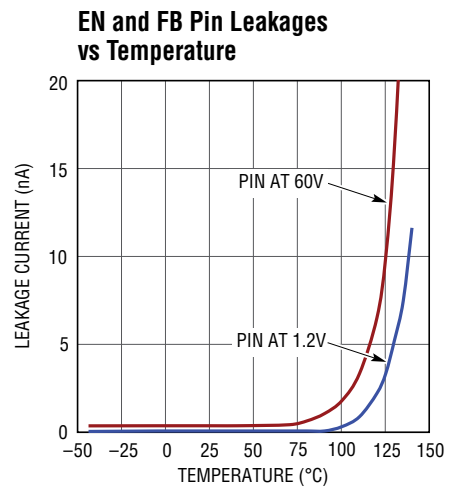

4079 G15

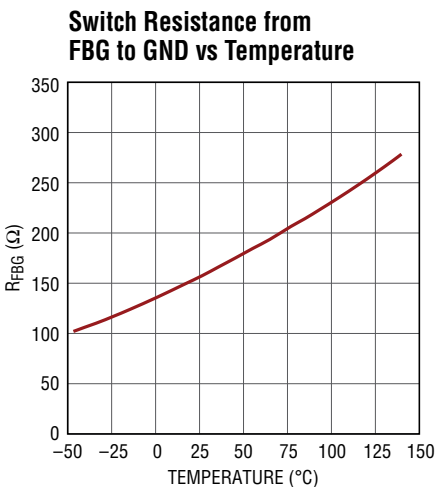

4079 G16

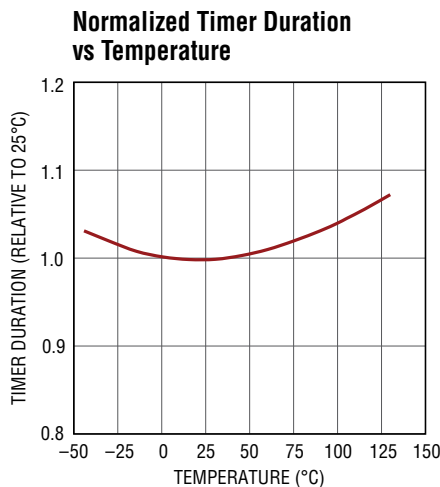

4079 G17

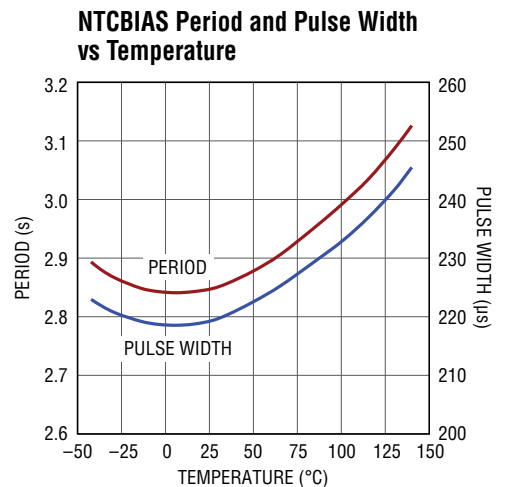

4079 G18

PIN FUNCTIONS

IN (Pin 1): Input Supply Pin. This input provides power to the battery charger. Bypass this pin with a ceramic capacitor of at least 1 μ F.

EN (Pin 2): Enable Input. Charge current starts flowing when this input rises above 1.190V, its regulation threshold. When using a current limited power source, connect this input to an external resistor divider from IN to GND to avoid UVLO oscillations. This configuration can also be used to maintain the source voltage (IN pin) at the maximum power threshold (e.g., for solar panel). Pulling this pin below 0.750V shuts down the device. This pin should not be left floating.

PROG (Pin 3): Charge Current Program Pin. The current out of this pin is 1/250th of the current out of the BAT pin. A resistor connected from PROG to ground sets the charge current in constant-current mode. This pin servos to 1.190V during constant-current charging. Do not leave this pin open. Limit parasitic capacitance on this node to less than 50pF.

NTCBIAS (Pin 4): NTC Thermistor Bias Output. Connect a low drift bias resistor from NTCBIAS to NTC pin, and a thermistor from NTC pin to GND. The value of the bias resistor is typically equal to the nominal resistance of the thermistor at 25°C. Minimize parasitic capacitance on this pin.

NTC (Pin 5): Input to the Battery Temperature Sense Circuit. Connect the NTC pin to a negative temperature coefficient (NTC) thermistor, which is typically co-packaged with the battery, to signal the charger if the battery is too hot or too cold to charge. The room temperature value of the thermistor should be at least 2k Ω . If the battery's temperature is out of range, charging is paused until the battery temperature re-enters the valid range. Connect a 1%, low drift bias resistor from NTCBIAS to NTC and a thermistor from NTC to ground. Minimize parasitic capacitance on this pin. Tie the NTC pin to GND to disable battery temperature sensing.

TIMER (Pin 6): Timer Capacitor Input. A capacitor on this pin sets the maximum duration for battery charging from charger enable or from the beginning of a recharge cycle.

For maximum charge duration of t_{TIMER} (in Hours), the required capacitance value can be determined as follows:

$$C_{\text{TIMER}} = (t_{\text{TIMER}} \cdot 18.2\text{nF/Hr})$$

A typical value of C_{TIMER} is 100nF which terminates the charge cycle after 5½ hours. Minimize leakage on this pin to maintain timer accuracy.

The timer is disabled when this pin is tied to GND. In this case charging terminates when the charge current falls below 1/10th of the programmed charge current I_{CHG} .

CHRG (Pin 7): Open-Drain Charge Status Output. Typically pulled up to a voltage source through a resistor or a low power LED and a resistor. This pin is pulled low by an internal NMOS when LTC4079 is charging the battery. The pin goes to high impedance when the charge current drops below 1/10th of the programmed current, or the charge cycle is timer terminated.

FBG (Pin 8): Ground Reference for Battery Voltage Divider. This pin is connected to ground internally through an NMOS switch when the battery is charging and disconnects the battery voltage divider from GND when it is not needed. When sensing the battery voltage the NMOS switch presents a low resistance ($R_{\text{FBG}} = 160\Omega$) to GND.

FB (Pin 9): Sense Pin for Divided Battery Voltage. This pin servos to 1.170V ($V_{\text{FB(CHG)}}$) during the constant-voltage phase of the battery charge algorithm. The battery charge voltage is set by using an appropriate resistor divider from BAT to FB to FBG. Minimize leakage and parasitic capacitance on this pin.

BAT (Pin 10): Battery Charger Output. This pin provides charge current to the battery.

GND (Exposed Pad Pin 11): Ground. The exposed pad must be soldered to a continuous ground plane of the printed circuit board for electrical connection and the rated thermal performance.

BLOCK DIAGRAM

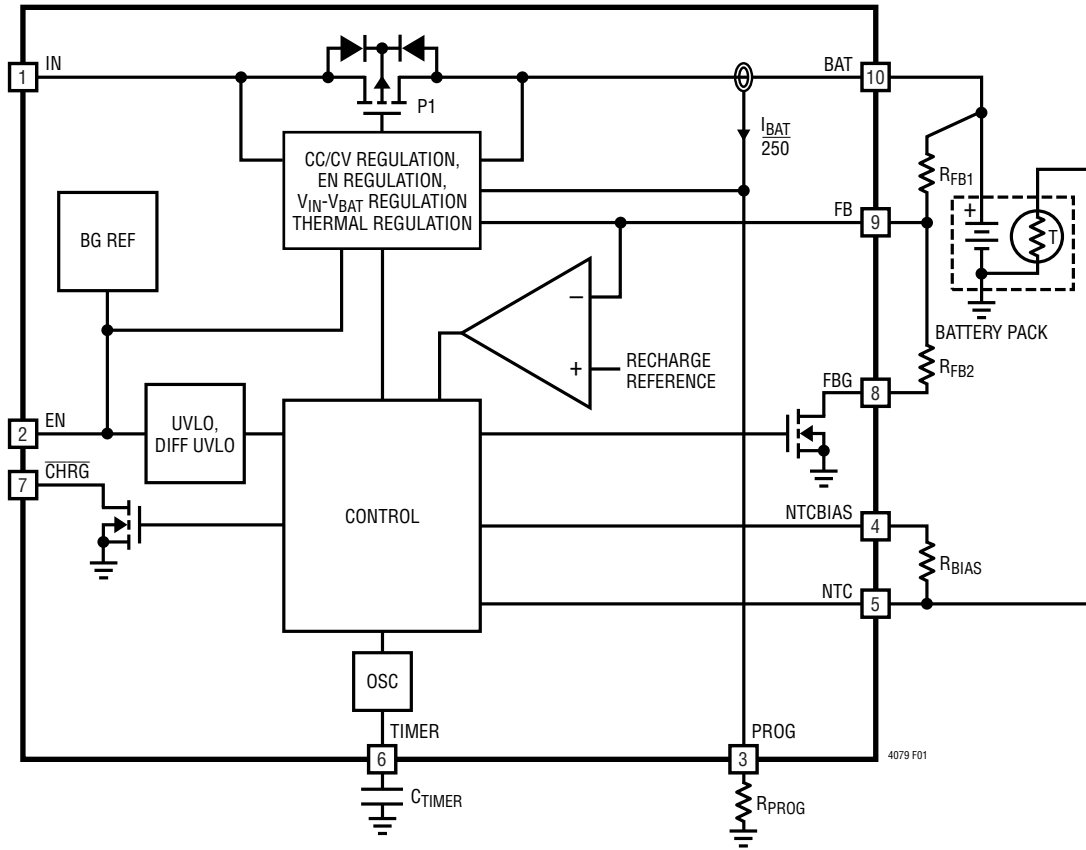

Figure 1. Block Diagram of LTC4079

OPERATION

The LTC4079 is a full featured constant-current, constant-voltage charger designed to charge multiple chemistry types of batteries from voltage sources up to 60V. The low quiescent current of the device minimizes power drain on the source and the battery, making it suitable for a variety of applications including backup and energy harvesting from an intermittent power source. The battery charge voltage is set using an external resistor divider. Charge duration can be set using a capacitor on the TIMER pin. For safety and improved battery life, the LTC4079 includes a thermistor input for temperature qualified charging.

Charge current starts when the EN pin is brought above 1.190V. Figure 2 shows a flow chart of the primary states and state transitions of the LTC4079. A typical charge cycle includes:

1. Constant-Current (CC) Charging: The programmed charge current is used to charge the battery until the battery voltage reaches the charge voltage set using the feedback divider. For a low ESR battery, this mode provides the bulk of the charge. The charge timer should generally be set long enough to charge the battery above the recharge threshold, otherwise another charge cycle would immediately follow.

2. Constant-Voltage (CV) Charging: Once the battery reaches the set charge voltage, constant voltage is maintained across the battery by controlling the charge current. The charge current reduces with time in this mode as the battery nears its full charge capacity.

3. Charging Termination: The LTC4079 can be configured to terminate charging automatically based on time or current. The $\overline{\text{CHRG}}$ status pin goes to high impedance when the charge current reduces below 1/10th of the programmed current, indicating that the battery is almost fully charged. The charge current continues to top-off the battery until the timer terminates the charge current. Timer termination can be disabled by connecting the TIMER pin to ground. In this case, charging terminates when the charge current falls below 1/10th of the programmed charge current.

A 6ms filter ($t_{\text{TERMINATE}}$) is used on the C/10 detector to prevent premature termination due to transient loads on the battery during charging.

4. Automatic Recharge: When V_{BAT} drops below the recharge threshold (97.6% of the charge voltage), whether by battery drainage or replacement of the battery, the charger automatically re-engages and starts charging.

Setting The Battery Charge Voltage

The battery charge voltage is set by connecting a resistor divider from the battery to the FB and FBG pins as shown in Figure 3. The charge voltage is determined as follows:

$$V_{\text{CHG}} = 1.170\text{V} \cdot \left(1 + \frac{R_{\text{FB1}}}{R_{\text{FB2}} + R_{\text{FBG}}} \right)$$

where R_{FB1} is the resistor from BAT to FB, R_{FB2} is the resistor from FB to FBG and R_{FBG} is the resistance of the internal switch of the FBG pin (160 Ω typical).

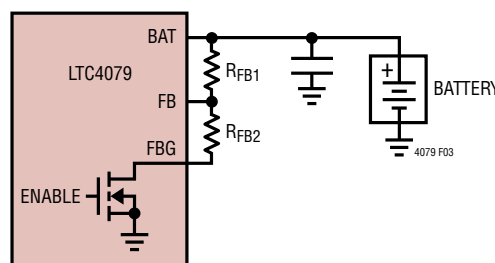

Figure 3. Setting the Battery Charge Voltage

Setting and Monitoring the Charge Current

The charge current delivered to the battery in constant-current mode, I_{CHG} is set using a resistor from the PROG pin to ground. The value of this resistor is calculated using:

$$R_{\text{PROG}} = \frac{297.5\text{V}}{I_{\text{CHG}}}$$

The PROG pin also provides a voltage signal proportional to the battery charge current. Therefore, the instantaneous battery current can be determined as follows by monitoring the PROG pin voltage:

$$I_{\text{BAT}} = \frac{250 \cdot V_{\text{PROG}}}{R_{\text{PROG}}}$$

Minimize the parasitic capacitance while monitoring the PROG pin voltage as any capacitance on this pin forms a pole that may cause instability in the charge control loop.

OPERATION

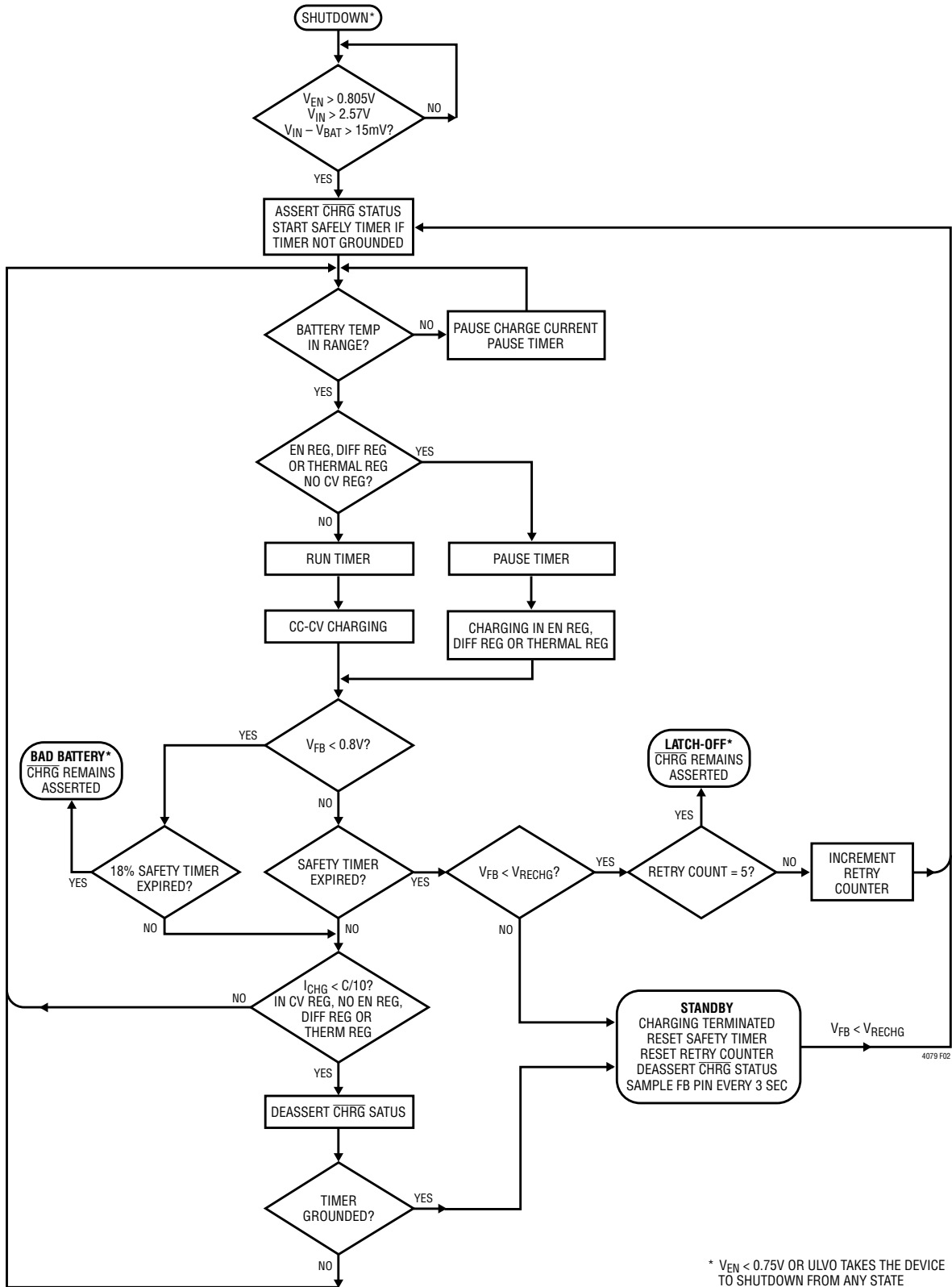

* $V_{EN} < 0.75V$ OR $ULVO$ TAKES THE DEVICE TO SHUTDOWN FROM ANY STATE

Figure 2. Battery Charger Operations Flow Chart

OPERATION

Undervoltage Detection

An internal undervoltage lockout circuit monitors the V_{IN} voltage and disables the battery charging circuit until V_{IN} rises above the undervoltage lockout threshold, 2.55V (typically). The UVLO threshold has built-in hysteresis of 140mV. Furthermore, the differential UVLO circuit also keeps the charger in a low quiescent current mode by disabling the battery charging circuits when V_{IN} falls below V_{BAT} by more than 65mV. The differential UVLO has hysteresis of 80mV, with turn-on at $V_{IN}-V_{BAT} = 15\text{mV}$ (typical).

Battery Temperature Qualified Charging

During battery charging, the battery temperature is sensed by sampling the voltage on the NTC pin every 3 seconds. Connect a low drift bias resistor from the NTCBIAS output to the NTC input and a negative temperature coefficient (NTC) thermistor, close to the battery pack, from the NTC pin to ground, as shown in Figure 4. The bias resistor should be equal to the value of the chosen thermistor at 25°C.

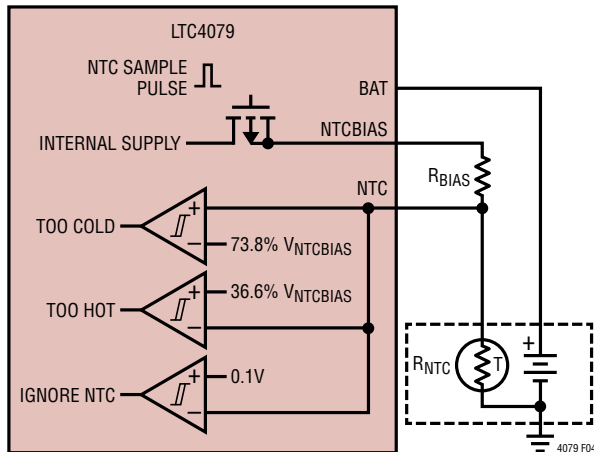

Figure 4. Battery Temperature Sensing Using NTC Thermistor

The LTC4079 pauses charging and the charge timer when the NTC pin voltage indicates that the thermistor resistance has dropped to 0.576 times its room temperature value. For a Vishay curve 2 thermistor, this corresponds to 40°C. Charging is also paused when the thermistor resistance increases to 2.816 times the room temperature value. For a Vishay curve 2 thermistor, this increase corresponds to 0°C.

The hot and cold trip points can be adjusted using a different type of thermistor, or a different R_{BIAS} resistor, or by adding a desensitizing resistor in series with the thermistor, or by a combination of these measures.

Charging resumes when the battery temperature returns to the normal range and the timer continues from the point where it was paused.

Input Voltage Regulation

The LTC4079 can regulate a constant voltage on the IN pin when charging from a current-limited power source such as a weak battery or a solar panel. This feature can be used to prevent the input voltage from collapsing below UVLO, or to maintain the input source voltage at peak power. The charge current is reduced as the input voltage falls to the threshold set by an external resistor divider from the input power source to the EN pin and GND, as shown in Figure 5. The input voltage regulation threshold, $V_{IN(REG)}$ is calculated as follows:

$$V_{IN(REG)} = 1.190\text{V} \cdot \left(1 + \frac{R_{EN1}}{R_{EN2}} \right)$$

This regulation mechanism allows the charge current to be selected based on battery requirement and the maximum power available from the charging source. The LTC4079 automatically reduces the charge current when the input source cannot provide the programmed charge current.

When input voltage regulation is not needed, connect the EN pin to the input power source or a digital enable signal.

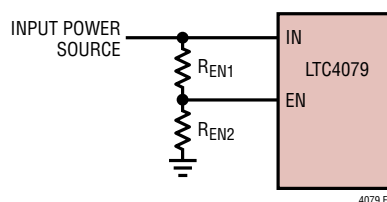

Figure 5. Setting Input Voltage Regulation

OPERATION

Differential Voltage ($V_{IN}-V_{BAT}$) Regulation

The LTC4079 provides an additional method to keep the input voltage from collapsing when the input power comes from a weak power source. If the input voltage falls close to the battery voltage, the differential voltage regulation loop in LTC4079 keeps the input voltage above the battery voltage by 160mV (typical value) by reducing the charge current as the input to battery differential voltage falls.

In both of the above regulation conditions, the input source must provide at least the quiescent current of the device to prevent UVLO. The charge timer is paused whenever the charge current is reduced due to input voltage regulation or differential voltage regulation.

Thermal Regulation

An internal thermal feedback loop reduces the charge current below the programmed value if the die temperature approaches 118°C. This feature protects the LTC4079 from excessive temperature and allows the user to set the charge current to typical (not worst case) ambient temperature with the assurance that the charger will automatically reduce the current to prevent overheating in worst-case conditions.

The charge timer is paused during thermal limiting to prevent under-charging the battery and to allow the full charge current to flow for the set timer duration.

C/10 Termination

The LTC4079 supports a current based termination scheme, where a battery charge cycle terminates when the current output from the charger falls below one-tenth of the programmed charge current. The C/10 threshold current corresponds to 119mV on the PROG pin. This termination mode is engaged by shorting the TIMER pin to ground.

When C/10 termination is used, the LTC4079 provides battery charge current as long as the current remains above the C/10 threshold. As the battery terminal voltage reaches the target charge voltage, the charge current falls until the C/10 threshold is reached, at which time the charger terminates and the LTC4079 enters standby mode.

Premature termination is prevented when input voltage, differential or thermal regulation is active.

To prevent termination-recharge oscillations, it is important to set the termination charge current low enough for batteries with high internal resistance. For a nominal recharge threshold of 2.4% below the charge voltage, the charge current should be set as follows with sufficient margin:

$$I_{CHG} < 0.24 \cdot \left(\frac{V_{CHG}}{R_{BAT}} \right)$$

where R_{BAT} is the battery's internal series resistance. The \overline{CHRG} status pin is high impedance when the charger is not actively charging.

Timer Termination

The LTC4079 also supports a timer-based termination scheme, where the battery charge cycle is terminated after a specific amount of time elapses. Connect a capacitor from the TIMER pin to ground to engage timer based charge termination. Calculate the capacitance required for the desired charge cycle duration, t_{TIMER} as follows:

$$C_{TIMER} = t_{TIMER} \cdot 18.2nF/Hr$$

A 200nA current source is used to source/sink current to/from C_{TIMER} to generate a sawtooth periodic signal (nominally 0.8V to 1.2V) for use by the timer. Since the TIMER pin current is small, minimize leakage on this pin to maintain timer accuracy.

The timer starts on charger enable or the beginning of a recharge cycle, and is reset on disable or when V_{IN} falls below UVLO or DUVLO.

The timer is paused whenever the charge current is limited by EN pin or differential voltage or thermal regulation, unless the charger is also in constant-voltage regulation mode. It is also paused with the charge current during an NTC fault. The timer is not paused if the charge current is limited by dropout. For example, for a programmed charge current of 100mA, this occurs when $V_{IN}-V_{BAT}$ falls below about 0.5V due to the voltage drop across the charge path (5Ω typically). If $V_{IN}-V_{BAT}$ falls below 160mV to trigger differential voltage regulation, the timer will be paused.

OPERATION

The $\overline{\text{CHRG}}$ status pin signals charging at a rate of more than $C/10$, regardless of which termination scheme is used. When timer termination is used, the $\overline{\text{CHRG}}$ status pin pulls low during a charging cycle until the charger output current falls below the $C/10$ threshold. The charger continues to top off the battery until timer termination, when the LTC4079 enters standby mode.

Standby and Automatic Recharge

If the LTC4079 remains enabled after charge cycle termination, it monitors the battery voltage in standby mode by sampling the FB pin connected to the external resistor divider. In order to minimize the battery drain, the feedback divider is only turned on (by connecting FBG pin to ground) for $210\mu\text{s}$ once every 3 seconds. When this sampling detects that the battery voltage has dropped by more than 2.4%, the feedback divider is kept on for 1.5 seconds (typical). If the FB voltage remains below the recharge threshold for more than 2.5ms (typical), a recharge cycle starts. This 2.5ms filter prevents premature recharge due to load transients. The recharge cycle also terminates in constant-voltage charge mode as described above. The automatic recharge function maintains that the battery at, or near, a fully charged condition.

If the battery voltage remains below the recharge threshold on timer expiration, another recharge cycle begins as explained below.

Timer Retry and Latch-off

A new charge cycle is started if the battery voltage remains below the recharge threshold at the end of a charge cycle. This happens in the following situations: 1) the timer is not set long enough for the battery with the programmed charge current, 2) the battery is defective, 3) a load drains the battery during charging, 4) charge current is limited by dropout.

In order to avoid wasting power in recharging a defective battery indefinitely, LTC4079 contains a recharge latch-off feature. Charging is latched off and the $\overline{\text{CHRG}}$ pin remains asserted after 5 recharge attempts if the battery voltage remains below the recharge threshold at the end of all

five recharge cycles. The latch-off counter is reset if a charge cycle terminates normally during any recharge attempt, or if the charge current falls below $I_{\text{CHG}}/10$ in constant-voltage regulation mode during a charge cycle. Charger disable using the EN pin or UVLO also resets the latch-off counter.

Bad Battery Scenario

If the feedback voltage remains below $V_{\text{FB(LOWBAT)}}$ for longer than 18% of the safety timer set by C_{TIMER} , the battery is considered bad. Charging stops in this case and the $\overline{\text{CHRG}}$ pin remains asserted. NTC sampling and FB sampling for recharge is also turned-off. The charge cycle is restarted by toggling the EN pin below $V_{\text{EN(SD)}}$ (typically 0.75V) and then back high. UVLO also clears the bad battery lockout. There is no bad battery detection when the battery charge timer is disabled (TIMER pin grounded).

$\overline{\text{CHRG}}$ Status Output

The charge status open-drain output ($\overline{\text{CHRG}}$) has two states: pull down and high impedance. The pull-down state indicates that LTC4079 is in charging mode. A high impedance state indicates that the charge current has dropped below 10% of the programmed charge current. In most cases, charge current is reduced due to the constant-voltage loop, meaning that the battery voltage is near the target charge voltage. But if charge current is reduced due to V_{IN} regulation (through EN or $V_{\text{IN}}-V_{\text{BAT}}$ regulation) or thermal regulation, $\overline{\text{CHRG}}$ remains asserted until only the constant-voltage regulation loop reduces charge current below 10% of the programmed charge current.

A high impedance state at the $\overline{\text{CHRG}}$ pin occurs on timer termination, or UVLO or differential UVLO, or when the LTC4079 is disabled by pulling EN low. This output can be used as a logic interface or to light a low power LED.

APPLICATIONS INFORMATION

Feedback Divider Selection

Using too low or too high values of resistors for the feedback divider can cause small charge voltage errors due to: 1) Finite on-resistance of the internal switch on the FBG pin and 2) leakage on the FB pin. The impact of these two factors on the target battery charge voltage is calculated as follows:

$$V_{\text{CHG}} = 1.170\text{V} \cdot \left(1 + \frac{R_{\text{FB1}}}{R_{\text{FB2}} + R_{\text{FBG}}} \right) + R_{\text{FB1}} \cdot (I_{\text{FB}} + I_{\text{LEAK}})$$

where R_{FB1} and R_{FB2} are the top and bottom resistors of the feedback divider, R_{FBG} is the resistance of the internal switch from the FBG pin to GND (160 Ω typical) and I_{LEAK} is the parasitic leakage on the FB pin as shown in Figure 6. A graph of I_{FB} vs Temperature is given in the Typical Performance Characteristics section.

According to the above equation, high value feedback resistors minimize the impact of R_{FBG} , while low values minimize the impact of I_{FB} and I_{LEAK} . A Thevenin equivalent resistance of 100k to 500k on the FB node is generally a good compromise in most scenarios.

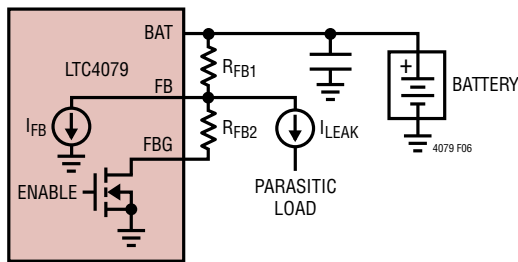

Figure 6. Feedback Divider Considerations

For example, for $R_{\text{FB1}} = 1.54\text{M}$ and $R_{\text{FB2}} = 249\text{k}$ (for battery charge voltage of 8.4V), accounting for $R_{\text{FBG}} = 160\Omega$ lowers the charge voltage by 0.06%, while $I_{\text{LEAK}} = 10\text{nA}$ raises it by 0.18%.

Table 1 lists possible choices of standard 1% resistor values for common battery charge voltages. The Typical Error column gives systematic error due to the granularity in the values of 1% resistors.

Table 1. Recommended 1% Resistors for Common Battery Charge Voltages

V_{CHG}	R_{FB1}	R_{FB2}	TYPICAL ERROR
3.6V	1070k	511k	+0.53%
4.1V	422k	169k	-0.27%
4.2V	1070k	412k	+0.18%
7.2V	1370k	267k	-0.42%
8.2V	1070k	178k	-0.04%
8.4V	1540k	249k	+0.02%
12.3V	1780k	187k	-0.02%
12.6V	2550k	261k	-0.05%

Stability Considerations

When the charger is in constant-current mode, the PROG pin impedance forms part of the charger current control loop. The constant-current mode stability is therefore affected by the roll-off frequency of the PROG pin impedance. With minimum capacitance on this pin (less than about 10pF), the charger is stable with a program resistor, R_{PROG} , as high as 60k ($I_{\text{CHG}} = 5\text{mA}$); however, any additional capacitance at this pin limits the maximum allowed program resistor.

The constant-voltage loop is stable without any compensation as long as a typical low impedance battery is connected to the BAT pin. However, a 1 μF capacitor with 1 Ω series resistor is recommended when charging high ESR batteries, typically more than 1k Ω .

Charging High Resistance Batteries

When charging a battery with high internal resistance, the battery voltage can rise quickly, entering constant-voltage mode. If the charge current falls below 1/10th of the programmed charge current, charging may terminate based on C/10 even if a timer capacitor is connected on the TIMER pin. This is because C/10 termination is assumed if the timer pin remains below 0.3V. With only 200nA being sourced from the TIMER pin, a large timer capacitance may limit the TIMER voltage below 0.3V for a short duration at the beginning of a charge cycle. After charging terminates, a recharge cycle would begin if the internal battery voltage has not been charged above the recharge threshold, determined by ΔV_{RECHRG} and the feedback divider. As

APPLICATIONS INFORMATION

shown in Figure 7, this charge/recharge cycle continues until the TIMER pin rises above 0.3V, at which point timer termination is engaged and the battery is charged for the duration set by the timer capacitor.

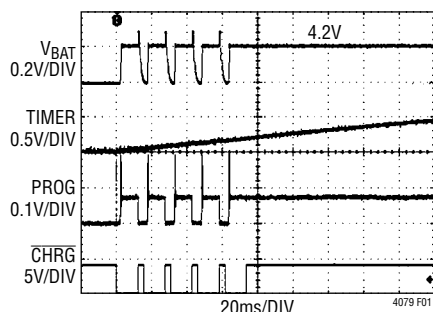

Figure 7. Repeated Charge Terminations on Startup Due to High Resistance of the Battery, $C_{TIMER} = 82\text{nF}$, $V_{CHG} = 4.2\text{V}$, $I_{CHG} = 10\text{mA}$ and Battery Resistance = 300Ω

Power Dissipation and Thermal Regulation

The LTC4079 automatically reduces charge current during high power conditions that result in high junction temperature. Therefore, it is not necessary to design the charging system for worst-case power dissipation scenarios. The conditions that cause the LTC4079 to reduce charge current through thermal regulation can be approximated by considering the power dissipated in the IC. Most of the power dissipation is in the charge path. Thus the power dissipation is approximately:

$$P_D = (V_{IN} - V_{BAT}) \cdot I_{BAT}$$

The approximate ambient temperature at which the thermal regulation begins to lower the charge current is:

$$T_A = 118^\circ\text{C} - P_D \cdot \theta_{JA}$$

$$T_A = 118^\circ\text{C} - (V_{IN} - V_{BAT}) \cdot I_{BAT} \cdot \theta_{JA}$$

The reduced charge current at an ambient temperature above the onset of thermal regulation can be calculated as follows:

$$I_{BAT} = \frac{118^\circ\text{C} - T_A}{(V_{IN} - V_{BAT}) \cdot \theta_{JA}}$$

Example: Consider an LTC4079 operating from a 12V input source programmed to supply 100mA current to a discharged 2-cell Li-Ion battery with a voltage of 6.6V.

Assuming θ_{JA} is $43^\circ\text{C}/\text{W}$ the ambient temperature at which the charge current begins to fall due to thermal regulation is:

$$T_A = 118^\circ\text{C} - (12\text{V} - 6.6\text{V}) \cdot 100\text{mA} \cdot 43^\circ\text{C}/\text{W} = 95^\circ\text{C}$$

The LTC4079 can be used above 95°C ambient but the charge current will be reduced linearly from the programmed value of 100mA to 0mA as the ambient temperature increases from 95°C to 118°C .

Increasing Thermal Regulation Current

In applications with large V_{IN} to V_{BAT} drop, the charge current can be significantly reduced during thermal regulation. One way to increase the thermally regulated charge current is to dissipate some of the power in a resistor in series with the IN pin. This works well when the resistor value is designed to be small enough to avoid pushing the LTC4079 into dropout.

Input Capacitor Selection

When an input supply is connected to a portable product, the inductance of the cable and the high Q ceramic input capacitor form an L-C resonant circuit. While the LTC4079 is capable of withstanding input voltages as high as 62V, if the input cable does not have adequate mutual inductance or if there is not much impedance in the cable, it is possible for the voltage at the input of LTC4079 to reach as high as 2x the cable input voltage before it settles out. To prevent excessive voltage from damaging the LTC4079 during a hot insertion, it is best to have a low voltage coefficient capacitor at the supply input pin of the LTC4079.

Using a tantalum capacitor or an aluminum electrolytic capacitor for input bypassing, or paralleling with a ceramic capacitor will also reduce voltage overshoot during a hot insertion.

APPLICATIONS INFORMATION

Board Layout Considerations

When laying out the printed circuit board, the following checklist should be followed to ensure proper operation of the LTC4079:

1. Connect the exposed pad of the package (Pin 11) directly to a large PC board ground to minimize thermal impedance. Correctly soldered to a 1500mm² double sided 1oz copper board, the LTC4079 DFN package has a thermal resistance (θ_{JA}) of approximately 43°C/W. Failure to make good contact between the exposed pad on the backside of the package and an adequately sized ground plane results in much larger thermal resistance.
2. The top of the feedback divider resistor should be connected as close to the positive battery terminal as possible in order to avoid inaccuracies due to voltage drop in the charge current path. The negative terminal of the battery should be connected to the chip ground plane directly to avoid any ground loop induced charge voltage inaccuracy.
3. Minimize the parasitic capacitance and leakage on the FB node for stability and charge voltage accuracy.
4. Minimize the parasitic capacitance and leakage on the TIMER pin for timer accuracy.
5. Minimize the parasitic capacitance on the PROG pin for stable operation.
6. Minimize the parasitic capacitance and leakage on the EN pin if it is connected to a resistor divider from the input supply for input voltage regulation.

TYPICAL APPLICATIONS

LiFePO₄ Charger with Timer Termination

In the Figure 8 configuration, the input source charges the battery for 5½ hours and also supplies current to the load. The maximum current provided by the charger (on BAT pin) is limited to the charge current of 246mA set by the 1.21k resistor on the PROG pin. A small resistor is used in series with the input supply to reduce $V_{IN}-V_{BAT}$, and thereby increase the available charge current during thermal regulation. Once the battery is charged, it supplies power to the load until V_{BAT} falls below the recharge threshold, at which point a recharge cycle starts.

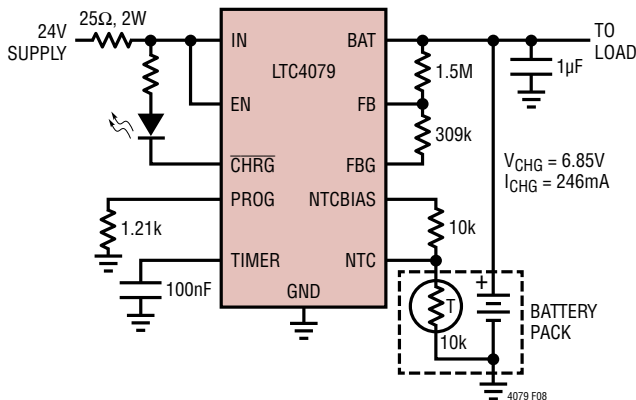

Figure 8. LiFePO₄ Charger with Timer Termination

2-Cell NiMH Trickle Charger from Automotive Supply with Timer Termination

Figure 9 shows a trickle charger for 2-cell, 2500mAh, AA NiMH battery with timer termination after 31 hours. Charge current drops when the battery voltage reaches 1.65V per cell.

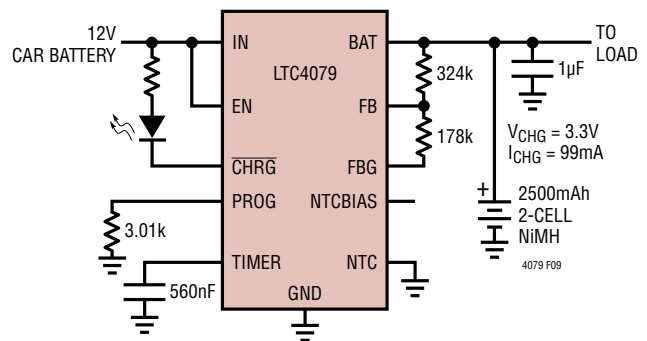

Figure 9. NiMH Trickle Charger with Timer Termination

TYPICAL APPLICATIONS

Li-Ion Charging from a Solar Panel with Differential Voltage Regulation, C/10 Termination

Figure 10 shows a simple charging solution from a solar panel. Differential voltage regulation reduces charge current to prevent the panel voltage from drooping below the battery voltage when charging under low light conditions. The LTC4079 does not require a Schottky diode in series with the panel.

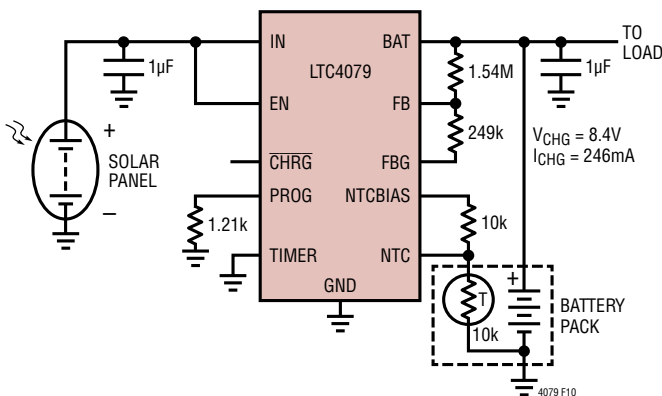

Figure 10. Li-Ion Charger with Differential Voltage Regulation

12V Lead-Acid Charger from Rectified 24V AC

In the following charging circuit example, a lead acid battery is trickle charged at a C/10 rate for 15 hours. An NTC thermistor is used to alter the target charge voltage of the lead-acid battery based on the battery temperature.

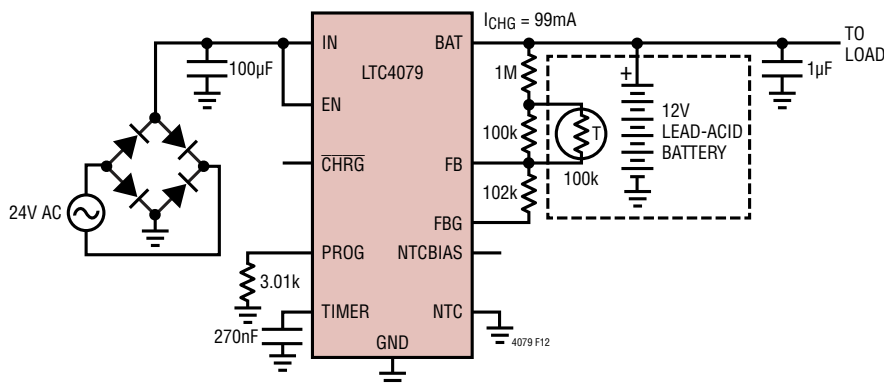

Figure 12. Lead-Acid Battery Trickle Charger from Rectified 24V AC

Supercapacitor Charger from 2-Cell Li-ion

Charging terminates when the stacked supercapacitor voltage reaches the set charge voltage. A recharge cycle begins automatically when the supercap voltage falls below the recharge threshold. A resistor divider balancer can optionally be switched in for balancing a stacked supercapacitor during charging.

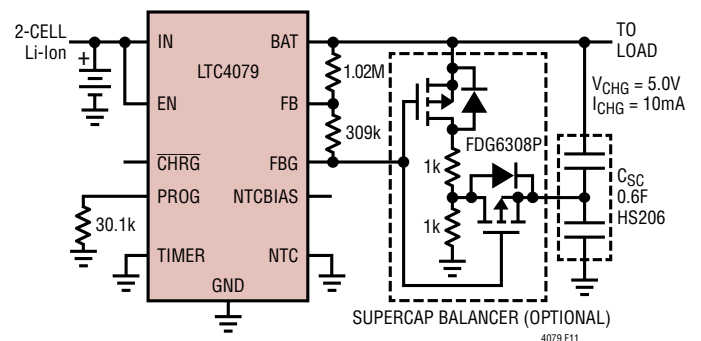
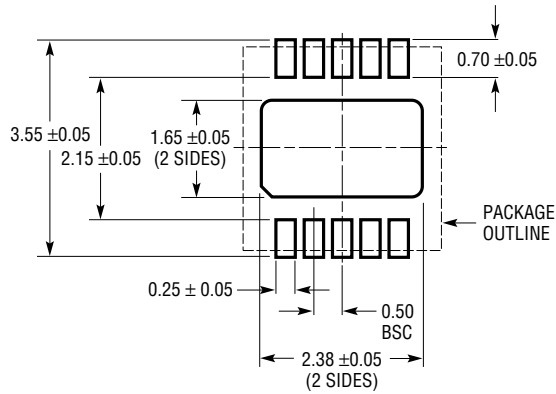

Figure 11. Supercap Charger with C/10 Termination

PACKAGE DESCRIPTION

DD Package
10-Lead Plastic DFN (3mm × 3mm)
 (Reference LTC DWG # 05-08-1699 Rev C)



RECOMMENDED SOLDER PAD PITCH AND DIMENSIONS

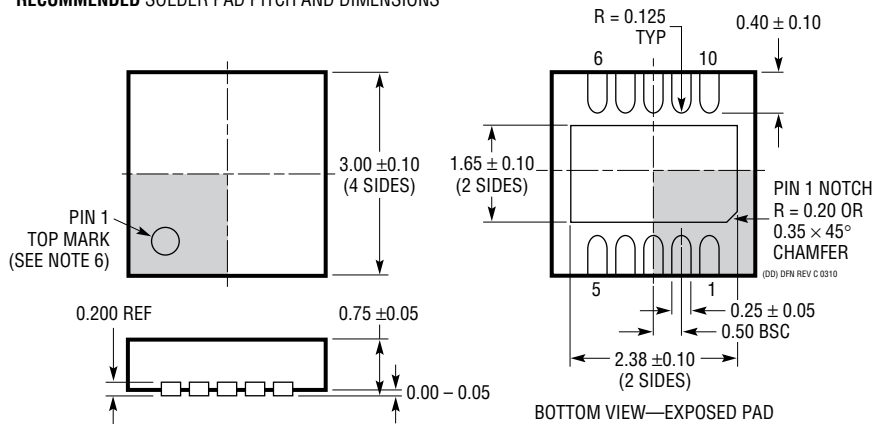

- NOTE:
1. DRAWING TO BE MADE A JEDEC PACKAGE OUTLINE MO-229 VARIATION OF (WEED-2). CHECK THE LTC WEBSITE DATA SHEET FOR CURRENT STATUS OF VARIATION ASSIGNMENT
 2. DRAWING NOT TO SCALE
 3. ALL DIMENSIONS ARE IN MILLIMETERS
 4. DIMENSIONS OF EXPOSED PAD ON BOTTOM OF PACKAGE DO NOT INCLUDE MOLD FLASH. MOLD FLASH, IF PRESENT, SHALL NOT EXCEED 0.15mm ON ANY SIDE
 5. EXPOSED PAD SHALL BE SOLDER PLATED
 6. SHADED AREA IS ONLY A REFERENCE FOR PIN 1 LOCATION ON THE TOP AND BOTTOM OF PACKAGE

REVISION HISTORY

REV	DATE	DESCRIPTION	PAGE NUMBER
A	05/21	AEC-Q100 Qualified for Automotive Applications. Updated Automotive Products #W to the Order Information.	1 2

TYPICAL APPLICATION

Energy Harvesting Charger with Buck, Buck-Boost and LDO Supplies

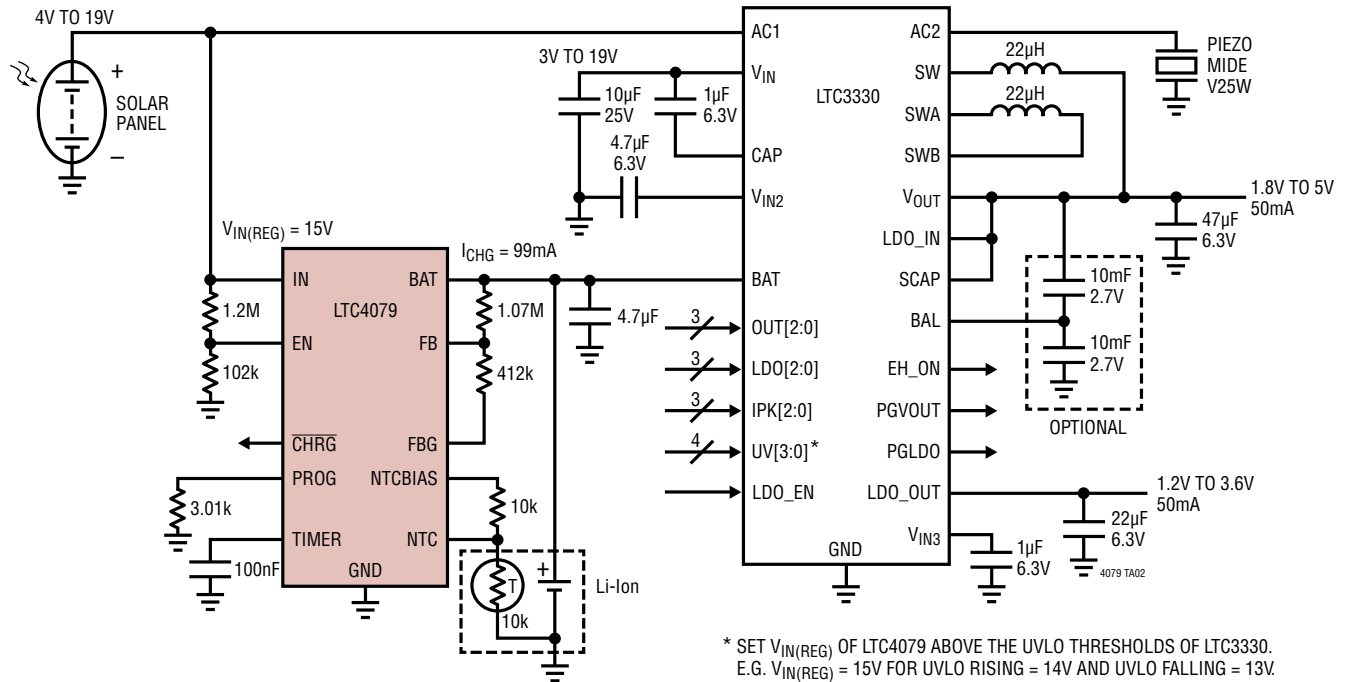

RELATED PARTS

PART NUMBER	DESCRIPTION	COMMENTS
LTC4078	Dual Input Li-Ion Battery Charger with Overvoltage Protection	Overvoltage Protection Up to 22V, Charge Current 100mA to 950mA
LTC4065/LTC4065A	250mA Li-Ion Battery Charger	3.75V to 5.5V Input, Up to 250mA Programmable Charge Current, Internal 4.5Hrs Safety Timer
LTC4054L-4.2	150mA Linear Li-Ion Battery Charger	4.25V to 6.5V Input, 10mA to 150mA Programmable Charge Current
LTC4070	Li-Ion/Polymer Shunt Battery Charger	I _Q = 0.5μA, Pin Selectable Battery Charge Voltage: 4.0V, 4.1V or 4.2V
LTC4071	Li-Ion/Polymer Shunt Battery Charger with Low Battery Disconnect	Pack Protection Version of LTC4070
LT®3650	High Voltage 2A Monolithic Li-Ion Battery Charger	4.75V to 32V Input, Buck Architecture
LTC4121/LTC4121-4.2	High Voltage 400mA Synchronous Step-Down Battery Charger	4.4V to 40V Input, Low Dropout Buck Architecture with MPPT