

- NOTES:
- MATERIAL: HOUSING - LIQUID CRYSTAL POLYMER (LCP) GLASS-FILLED. UL 94V-0. COLOR - BLACK. SIGNAL AND SHIELD - HIGH PERFORMANCE COPPER ALLOY.
 - FINISHES:
CONTACT AREA: SELECTIVE GOLD (Au)
PCB TAILS: SELECTIVE TIN/LEAD (Sn/Pb) OR SELECTIVE MATTE TIN (Sn) NICKEL (Ni) OVERALL.
 - THIS PART CONFORMS TO MOLEX PRODUCT SPECIFICATION PS-74031-999.
 - FOR MIXED CONTACT MATING LENGTHS CONSULT MOLEX FOR AVAILABILITY.
 - FOR SPECIFIC PART NUMBER AND MATING INFORMATION REFER TO SHEET 2.
 - PACKAGE PER PK-74057-003 FOR 10 & 25 COLUMN. PACKAGE PER PK-70873-0934 FOR THE 9 COLUMN CONNECTOR.
 - EITHER MARK PART NUMBER AND DATE CODE APPROXIMATELY WHERE SHOWN OR PLACE LABEL ON TUBE.
 - MAPS (MOLEX ADVANCED PLATING SYSTEM).

THE PRIMARY CARTON WITH A LABEL STATING "ELV AND RoHS COMPLIANT" IS LEAD FREE. CARTONS WITHOUT THIS LABEL MAY CONTAIN LEAD.

CORRECT PART NUMBERS EC NO: UCP2017-1186 DRAWN: MORGAN 2016/11/22 CHKD: APPR: TELD 2016/11/29	DESCRIPTION REV	QUALITY SYMBOLS	GENERAL TOLERANCES (UNLESS SPECIFIED)		DIMENSION STYLE MM ONLY		SCALE 4:1	DESIGN UNITS METRIC	THIRD ANGLE PROJECTION
		▽=0	mm	INCH	DRAWN BY NMARTIN	DATE 2002/05/03	TITLE HSD 6 ROW OPEN END BACKPLANE SALES DRAWING molex	DOCUMENT NO. SD-74979-010	SHEET NO. 1 OF 2
		▽=0	4 PLACES ± ---	± ---	CHECKED BY SREED	DATE 2002/05/03			
		▽=0	3 PLACES ± ---	± ---	APPROVED BY CBIXLER	DATE 2002/05/03			
	2 PLACES ± 0.25	± ---	MATERIAL NO. SEE TABLE						
		1 PLACE ± 0.38	± ---	SIZE C		THIS DRAWING CONTAINS INFORMATION THAT IS PROPRIETARY TO MOLEX INCORPORATED AND SHOULD NOT BE USED WITHOUT WRITTEN PERMISSION			
		0 PLACE ±	±	ANGULAR ± ---°					
		DRAFT WHERE APPLICABLE MUST REMAIN WITHIN DIMENSIONS							

MATERIAL NUMBER ASSIGNMENT

74979-** **

PIN LENGTH DIM 'M' / PLATING

- 1 & 6 = 4.75
- 2 & 7 = 6.25
- 3 & 8 = 4.25
- 4 & 9 = 5.15

- / 1 - 4 (10 OR 30 GOLD)
- / 6 - 9 (50 GOLD)

MODULE ORIENTATION OPEN = 0

NUMBER OF COLUMNS/PLATING

- 10 = 10 COLUMN TIN (FORMERLY TIN LEAD)
- 25 = 25 COLUMN TIN (FORMERLY TIN LEAD)
- 09 = 9 COLUMN TIN (FORMERLY TIN LEAD)
- 90 = 10 COLUMN MATTE TIN
- 85 = 25 COLUMN MATTE TIN
- 99 = 9 COLUMN MATTE TIN
- 60 = 10 COLUMN MATTE TIN (MAPS)
- 70 = 25 COLUMN MATTE TIN (MAPS)
- 69 = 9 COLUMN MATTE TIN (MAPS)

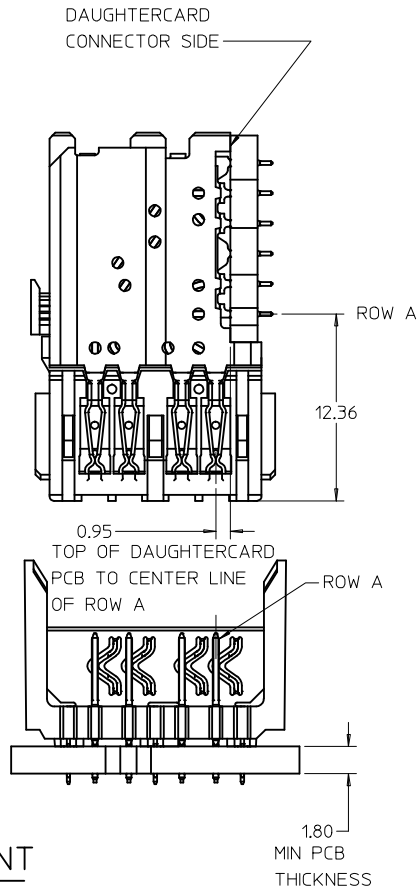
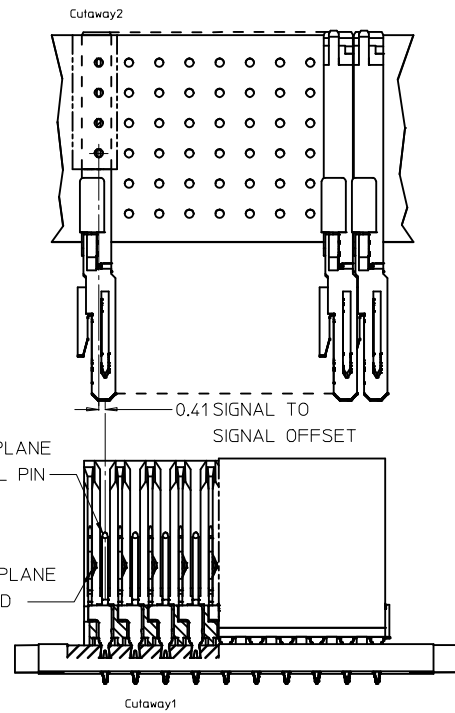

PART NUMBER	COLUMN	NUMBER OF SIGNAL PIN	NUMBER OF SHIELD	A	B	M	GOLD THICKNESS MICROMETER	TIN THICKNESS MICROMETER
74979-6901							0.25 MAPS	
74979-0901							0.76	
74979-0906							1.27	
74979-9901	9	36	9	18.00	16.00		0.76	
74979-9906							1.27	
74979-6001							0.25 MAPS	
74979-1001							0.76	
74979-1006	10	40	10	20.00	18.00	4.75	1.27	
74979-9001							0.76	
74979-9006							1.27	
74979-7001							0.25 MAPS	
74979-2501							0.76	
74979-2506	25	100	10	50.00	48.00		1.27	
74979-8501							0.76	
74979-8506							1.27	
74979-6902							0.25 MAPS	
74979-0902	9	36	9	18.00	16.00		0.76	
74979-0907							1.27	
74979-9902							0.76	
74979-9907							1.27	
74979-6002							0.25 MAPS	
74979-1002							0.76	
74979-1007	10	40	10	20.00	18.00	6.25	1.27	
74979-9002							0.76	
74979-9007							1.27	
74979-7002							0.25 MAPS	
74979-2502							0.76	
74979-2507	25	100	10	50.00	48.00		1.27	
74979-8502							0.76	
74979-8507							1.27	
74979-6903							0.25 MAPS	
74979-0903	9	36	9	18.00	16.00		0.76	
74979-0908							1.27	
74979-9903							0.76	
74979-9908							1.27	
74979-6003							0.25 MAPS	
74979-1003							0.76	
74979-1008	10	40	10	20.00	18.00	4.25	1.27	
74979-9003							0.76	
74979-9008							1.27	
74979-7003							0.25 MAPS	
74979-2503							0.76	
74979-2508	25	100	10	50.00	48.00		1.27	
74979-8503							0.76	
74979-8508							1.27	
74979-6904							0.25 MAPS	
74979-0904	9	36	9	18.00	16.00		0.76	
74979-0909							1.27	
74979-9904							0.76	
74979-9909							1.27	
74979-6004							0.25 MAPS	
74979-1004							0.76	
74979-1009	10	40	10	20.00	18.00	5.15	1.27	
74979-9004							0.76	
74979-9009							1.27	
74979-7004							0.25 MAPS	
74979-2504							0.76	
74979-2509	25	100	10	50.00	48.00		1.27	
74979-8504							0.76	
74979-8509							1.27	

SEE SHEET 1 EC NO: UCP2017-1186 DRWINGMORGAN 2016/11/22 CHKD: APPR:TELO 2016/11/29	QUALITY SYMBOLS ▽=0 ▽=0 ▽=0	GENERAL TOLERANCES (UNLESS SPECIFIED)		DIMENSION STYLE MM ONLY		SCALE 4:1	DESIGN UNITS METRIC	THIRD ANGLE PROJECTION			
		4 PLACES ± --- ± ---	3 PLACES ± --- ± ---	2 PLACES ± 0.25 ± ---	1 PLACE ± 0.38 ± ---	0 PLACE ± ±	DRAWN BY NMARTIN	DATE 2002/05/03	TITLE HSD 6 ROW OPEN END BACKPLANE SALES DRAWING		
		ANGULAR ± --- °					CHECKED BY SREED	DATE 2002/05/03	APPROVED BY CBIXLER		
		DRAFT WHERE APPLICABLE MUST REMAIN WITHIN DIMENSIONS					MATERIAL NO. SEE TABLE	DATE 2002/05/03	DOCUMENT NO. SD-74979-010	SHEET NO. 2 OF 2	

THIS DRAWING CONTAINS INFORMATION THAT IS PROPRIETARY TO MOLEX. INCORPORATED AND SHOULD NOT BE USED WITHOUT WRITTEN PERMISSION

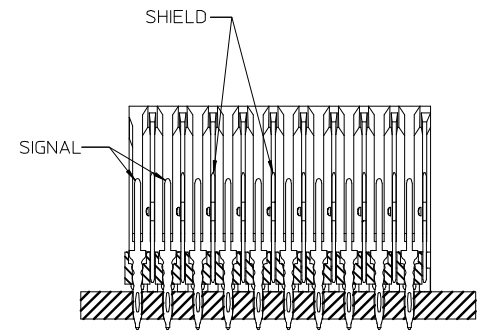
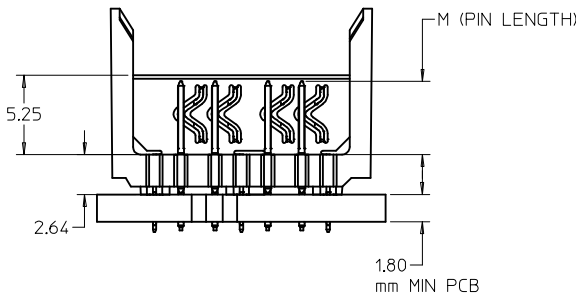
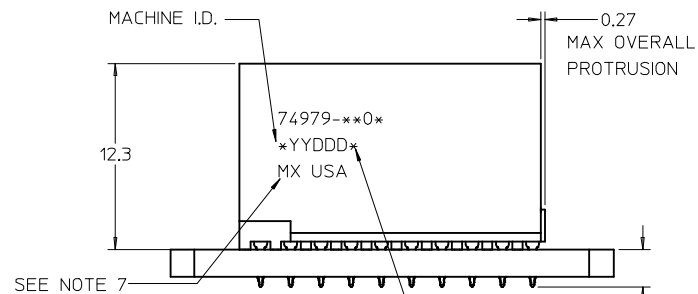
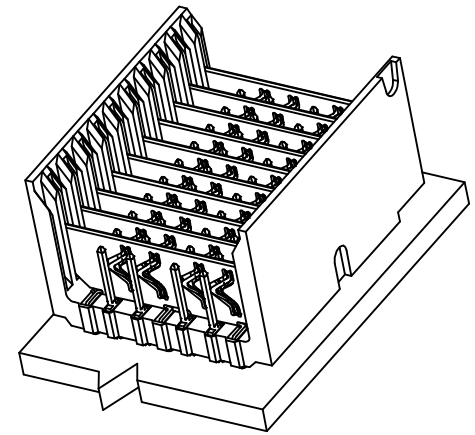
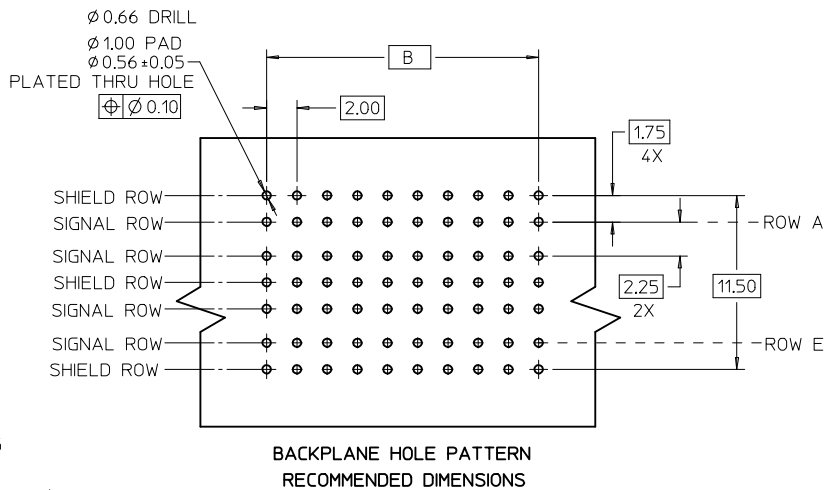
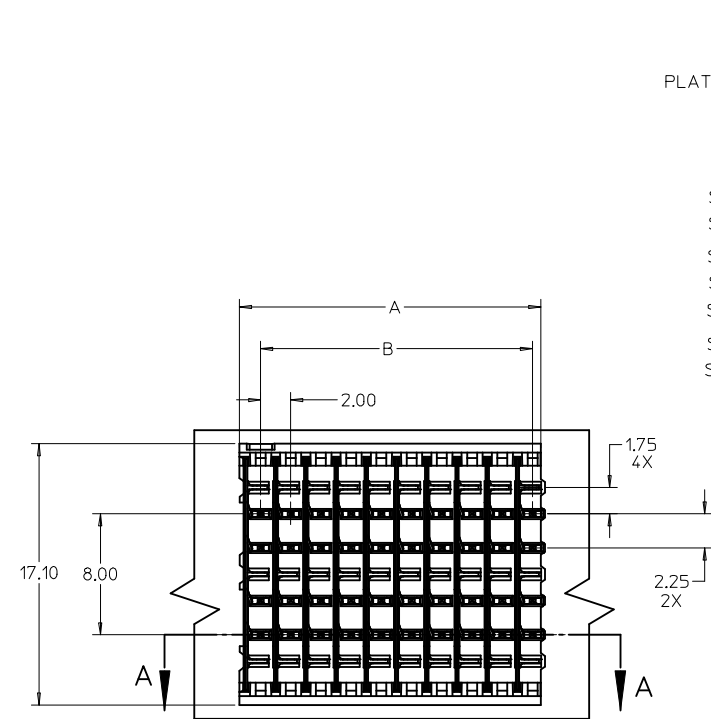

- NOTES:
- MATERIAL: HOUSING - LIQUID CRYSTAL POLYMER (LCP) GLASS-FILLED. UL 94V-0. COLOR - BLACK. SIGNAL AND SHIELD - HIGH PERFORMANCE COPPER ALLOY.
 - FINISHES:
CONTACT AREA: SELECTIVE GOLD (Au)
PCB TAILS: SELECTIVE TIN/LEAD (Sn/Pb) OR SELECTIVE MATTE TIN (Sn) NICKEL (Ni) OVERALL.
 - THIS PART CONFORMS TO MOLEX PRODUCT SPECIFICATION PS-74031-999.
 - FOR MIXED CONTACT MATING LENGTHS CONSULT MOLEX FOR AVAILABILITY.
 - FOR SPECIFIC PART NUMBER AND MATING INFORMATION REFER TO SHEET 2.
 - PACKAGE PER PK-74057-003 FOR 10 & 25 COLUMN. PACKAGE PER PK-70873-0934 FOR THE 9 COLUMN CONNECTOR.
 - EITHER MARK PART NUMBER AND DATE CODE APPROXIMATELY WHERE SHOWN OR PLACE LABEL ON TUBE.
 - MAPS (MOLEX ADVANCED PLATING SYSTEM).

THE PRIMARY CARTON WITH A LABEL STATING "ELV AND RoHS COMPLIANT" IS LEAD FREE. CARTONS WITHOUT THIS LABEL MAY CONTAIN LEAD.

CORRECT PART NUMBERS EC NO: UCP2017-1186 DRAWN: MORGAN 2016/11/22 CHKD: APPR: TELO 2016/11/29	DESCRIPTION REV	QUALITY SYMBOLS	GENERAL TOLERANCES (UNLESS SPECIFIED)		DIMENSION STYLE MM ONLY		SCALE 4:1	DESIGN UNITS METRIC	THIRD ANGLE PROJECTION
		▽=0	mm	INCH	DRAWN BY NMARTIN	DATE 2002/05/03	TITLE HSD 6 ROW OPEN END BACKPLANE SALES DRAWING molex DOCUMENT NO. SD-74979-010	SHEET NO. 1 OF 2	
		▽=0	4 PLACES ± ---	± ---	CHECKED BY SREED	DATE 2002/05/03			
		▽=0	3 PLACES ± ---	± ---	APPROVED BY CBIXLER	DATE 2002/05/03			
	2 PLACES ± 0.25	± ---	MATERIAL NO. SEE TABLE						
		1 PLACE ± 0.38	± ---	SIZE C		THIS DRAWING CONTAINS INFORMATION THAT IS PROPRIETARY TO MOLEX INCORPORATED AND SHOULD NOT BE USED WITHOUT WRITTEN PERMISSION			
		0 PLACE ±	±	DRAFT WHERE APPLICABLE MUST REMAIN WITHIN DIMENSIONS					

MATERIAL NUMBER ASSIGNMENT

74979-** **

- PIN LENGTH DIM "M" / PLATING
- 1 & 6 = 4.75
- 2 & 7 = 6.25
- 3 & 8 = 4.25
- 4 & 9 = 5.15
- / 1 - 4 (10 OR 30 GOLD)
- / 6 - 9 (50 GOLD)
- MODULE ORIENTATION OPEN = 0

- NUMBER OF COLUMNS/PLATING
- 10 = 10 COLUMN TIN (FORMERLY TIN LEAD)
- 25 = 25 COLUMN TIN (FORMERLY TIN LEAD)
- 09 = 9 COLUMN TIN (FORMERLY TIN LEAD)
- 90 = 10 COLUMN MATTE TIN
- 85 = 25 COLUMN MATTE TIN
- 99 = 9 COLUMN MATTE TIN
- 60 = 10 COLUMN MATTE TIN (MAPS)
- 70 = 25 COLUMN MATTE TIN (MAPS)
- 69 = 9 COLUMN MATTE TIN (MAPS)

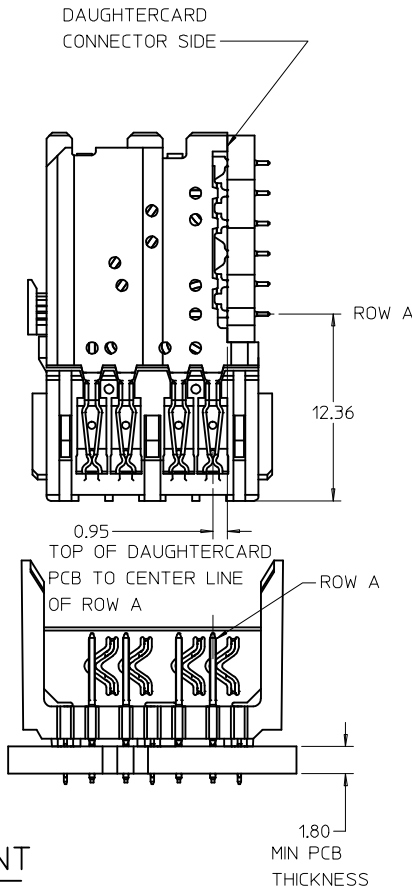
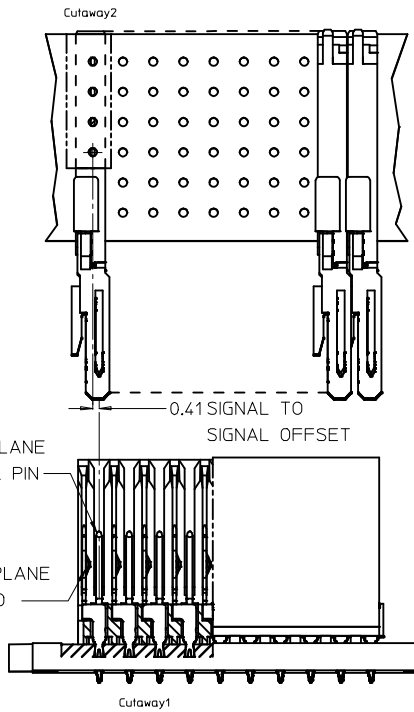

PART NUMBER	COLUMN	NUMBER OF SIGNAL PIN	NUMBER OF SHIELD	A	B	M	GOLD THICKNESS MICROMETER	TIN THICKNESS MICROMETER
74979-6901	9	36	9	18.00	16.00		0.25 MAPS	0.76-152
74979-0901							0.76	
74979-0906							1.27	
74979-9901							0.76	
74979-9906							1.27	
74979-6001	10	40	10	20.00	18.00	4.75	0.25 MAPS	
74979-1001							0.76	
74979-1006							1.27	
74979-9001							0.76	
74979-9006							1.27	
74979-7001	25	100	10	50.00	48.00		0.25 MAPS	
74979-2501							0.76	
74979-2506							1.27	
74979-8501							0.76	
74979-8506							1.27	
74979-6902	9	36	9	18.00	16.00		0.25 MAPS	
74979-0902							0.76	
74979-0907							1.27	
74979-9902							0.76	
74979-9907							1.27	
74979-6002	10	40	10	20.00	18.00	6.25	0.25 MAPS	
74979-1002							0.76	
74979-1007							1.27	
74979-9002							0.76	
74979-9007							1.27	
74979-7002	25	100	10	50.00	48.00		0.25 MAPS	
74979-2502							0.76	
74979-2507							1.27	
74979-8502							0.76	
74979-8507							1.27	
74979-6903	9	36	9	18.00	16.00		0.25 MAPS	
74979-0903							0.76	
74979-0908							1.27	
74979-9903							0.76	
74979-9908							1.27	
74979-6003	10	40	10	20.00	18.00	4.25	0.25 MAPS	
74979-1003							0.76	
74979-1008							1.27	
74979-9003							0.76	
74979-9008							1.27	
74979-7003	25	100	10	50.00	48.00		0.25 MAPS	
74979-2503							0.76	
74979-2508							1.27	
74979-8503							0.76	
74979-8508							1.27	
74979-6904	9	36	9	18.00	16.00		0.25 MAPS	
74979-0904							0.76	
74979-0909							1.27	
74979-9904							0.76	
74979-9909							1.27	
74979-6004	10	40	10	20.00	18.00	5.15	0.25 MAPS	
74979-1004							0.76	
74979-1009							1.27	
74979-9004							0.76	
74979-9009							1.27	
74979-7004	25	100	10	50.00	48.00		0.25 MAPS	
74979-2504							0.76	
74979-2509							1.27	
74979-8504							0.76	
74979-8509							1.27	

SEE SHEET 1	DESCRIPTION	QUALITY SYMBOLS
EC NO: UCP2017-1186	2016/11/22	▽=0
DRWING:MORGAN	2016/11/22	▽=0
CHKD:		▽=0
APPR:TELO		▽=0

GENERAL TOLERANCES (UNLESS SPECIFIED)	
mm	INCH
4 PLACES ± ---	± ---
3 PLACES ± ---	± ---
2 PLACES ± 0.25	± ---
1 PLACE ± 0.38	± ---
0 PLACE ±	±
ANGULAR ± ---°	
DRAFT WHERE APPLICABLE MUST REMAIN WITHIN DIMENSIONS	

DIMENSION STYLE	
MM ONLY	
DRAWN BY	DATE
NMARTIN	2002/05/03
CHECKED BY	DATE
SREED	2002/05/03
APPROVED BY	DATE
CBIXLER	2002/05/03
MATERIAL NO.	
SEE TABLE	
SIZE	
C	

SCALE	DESIGN UNITS	THIRD ANGLE PROJECTION
4:1	METRIC	☉
TITLE		
HSD 6 ROW OPEN END BACKPLANE SALES DRAWING		
molex		
DOCUMENT NO.	SHEET NO.	
SD-74979-010	2 OF 2	
THIS DRAWING CONTAINS INFORMATION THAT IS PROPRIETARY TO MOLEX. INCORPORATED AND SHOULD NOT BE USED WITHOUT WRITTEN PERMISSION		