

NOTES:

- 1 THIS TERMINAL IS FOR USE WITH .250/(6.35) X .032/(0.81) SPADES AND CRIMPING TO #10 TO #18 AWG WIRE WITH .031/(0.79) THICK INSULATION.
- 2 IN ANY HOUSING DESIGN USING THIS TERMINAL, ESPECIALLY WHEN LOW INSERTION FORCES ARE EXPECTED, SOME SORT OF LOCKING DEVICE SHOULD BE CONSIDERED.

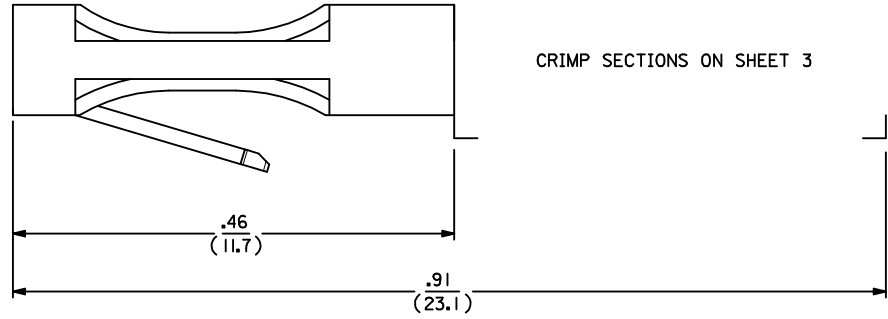
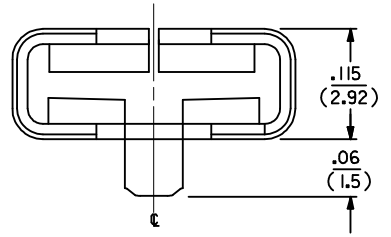
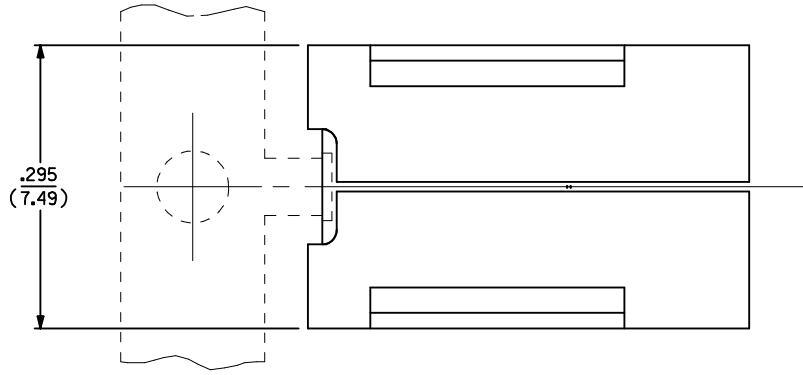

CRIMP SECTIONS ON SHEET 3

MATERIAL:
SEE SHEET 2
FINISH:
SEE SHEET 2

3	K1
2	H2
1	K3

FIX BLOCK TOLERANCE EC NO: UCP2013-0551 DRW: AELHAG 2012/06/12 CHKD: JELL 06/12/2012 APPR: FSMITH 2012/08/15	QUALITY SYMBOLS	GENERAL TOLERANCES (UNLESS SPECIFIED)	DIMENSION STYLE	SCALE	DESIGN UNITS	THIRD ANGLE PROJECTION
	▽=0	mm INCH	IN/MM	10:1	INCH	
	▽=0	4 PLACES ± --- ± ---	DRAWN BY DATE	TITLE TERMINAL PUSH-ON CRIMP		
	▽=0	3 PLACES ± --- ± .010	RWK 01/26/89			
	2 PLACES ± 0.25 ± .014	CHECKED BY DATE	MOLEX INCORPORATED SD-41422-3*			
	1 PLACE ± 0.35 ± ---	RHR 01/26/89				
	ANGULAR ± 1/2°	APPROVED BY DATE	DOCUMENT NO. SEE CHART			
	DRAFT WHERE APPLICABLE MUST REMAIN WITHIN DIMENSIONS	RAS 01/26/89				
		MATERIAL NO.	SHEET NO.			
		SIZE	1 OF 3			
			THIS DRAWING CONTAINS INFORMATION THAT IS PROPRIETARY TO MOLEX INCORPORATED AND SHOULD NOT BE USED WITHOUT WRITTEN PERMISSION			

PART NO.	ENG. NO.	MATERIAL	MATERIAL EDP NUMBER	FINISH		CONTACT GAP	WIRE RANGE	FORM
				PLATING	LUBRICATION			
040-02-1601	41422-3A2N5A1	A	080-02-1608	2	N	5	A	I
040-02-1602	41422-3A2N5B1	A	080-02-1608	2	N	5	B	I

41422

MATERIALS:

- A) BRASS, ALLOY #C26000, TEMPER: SPRING, .016/(0.4) THICK.
- B) COPPER, ALLOY #C19500, TEMPER: SPRING, .016/(0.4) THICK.
- C) BERYLLIUM COPPER, ALLOY #C17400, .016/(0.4) THICK.

FINISHES:

PLATING

- 2) HOT TIN DIP, SDES-88-P901.

ENGINEERING NUMBER SYSTEM

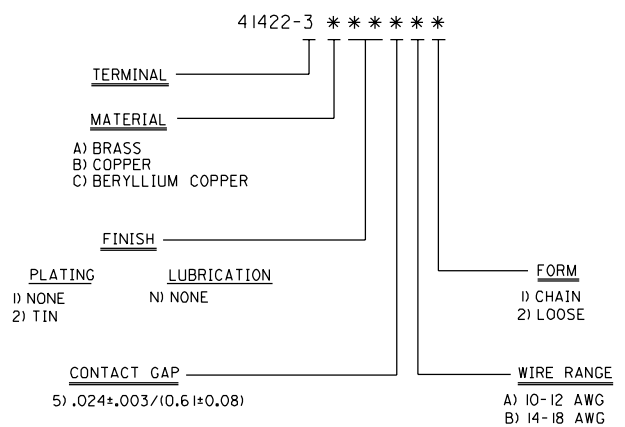

H2	SEE SHEET I
H1	SEE SHEET I
G1	SEE SHEET I
G	SEE SHEET I
F	SEE SHEET I
E	SEE SHEET I
D	SEE SHEET I
C	SEE SHEET I

DIMENSIONS SHOWN (METRIC) INCH		▽ = 0	▼ = 0	REVISE ONLY ON CAD SYSTEM
UNLESS OTHERWISE SPECIFIED TOLERANCES: ANGULAR ± .042		TITLE		
3 PLACE ±		TERMINAL, PUSH-ON, CRIMP		
2 PLACE ±		MOLEX INCORPORATED		
1 PLACE ±		LITSE,ILL. 60532 U.S.A.		
DRAFT WHERE APPLICABLE MUST REMAIN WITHIN DIMENSIONS		PART NO. SHEET NO. DATE		
DRWG. BY: RWK		SEE CHART SD-41422-3		
APP'D. BY: RAS		FILE NAME: T41422.S06		
SCALE: :		THIS DRAWING CONTAINS INFORMATION THAT IS PROPRIETARY TO MOLEX INC. AND SHOULD NOT BE USED WITHOUT WRITTEN PERMISSION.		

41422

14-18 AWG WIRE

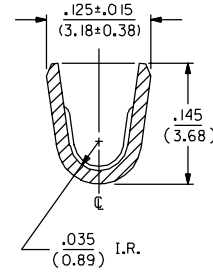
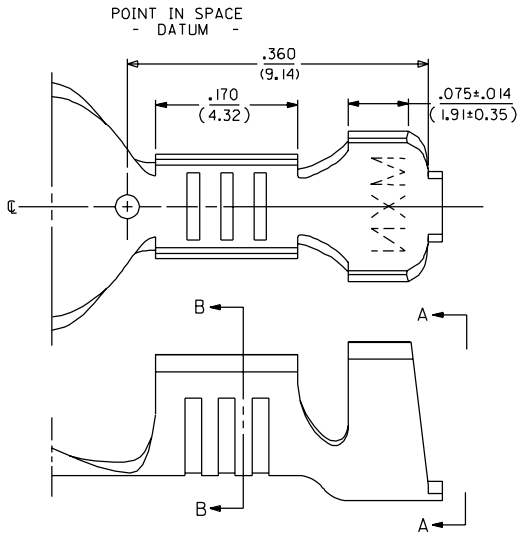

SECTION B-B

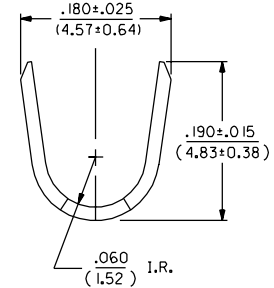

VIEW A

10-12 AWG WIRE

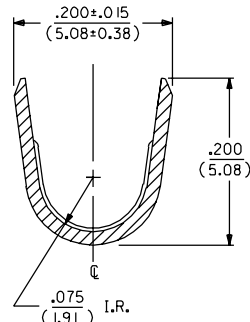
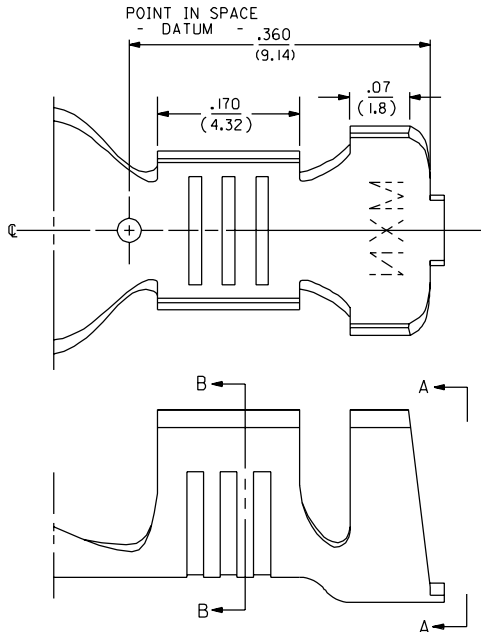

SECTION B-B

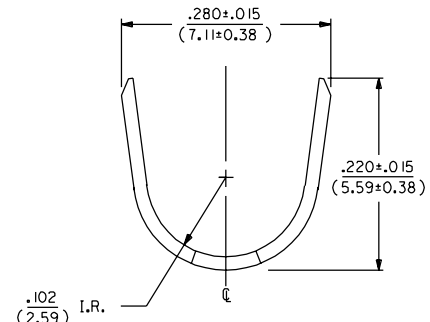

VIEW A

K	I SEE SHEET I
K	SEE SHEET I
I	SEE SHEET I
HI	SEE SHEET I
D	SEE SHEET I
C	SEE SHEET I

DIMENSIONS SHOWN METRIC (INCH)		▽ = 0	▽ = 0	REVISE ONLY ON CAD SYSTEM
UNLESS OTHERWISE SPECIFIED TOLERANCES ANGULAR ± .040°		TITLE		
INCH METRIC		TERMINAL, PUSH-ON, CRIMP		
3 PLACE ± .010	---	MOLEX INCORPORATED		
2 PLACE ± .014	± 0.25	L15LEJLL 60532 U.S.A.		
1 PLACE ---	± 0.35	SHEET NO. 3 DATE 01/30/89		
DRAFT WHERE APPLICABLE MUST REMAIN WITHIN DIMENSIONS		PART NO. SEE CHART DRWG. NO. SD-41422-3		
DRWG. BY RWK	CHKD. BY RHR	FILE NAME		
APP'D. BY	SCALE :	THIS DRAWING CONTAINS INFORMATION THAT IS PROPRIETARY TO MOLEX INC. AND SHOULD NOT BE USED WITHOUT WRITTEN PERMISSION.		