

BTS5016SDA

Smart High-Side Power Switch

PROFET™

One Channel

Automotive Power



Never stop thinking

Table of Contents

1	Overview	3
2	Block Diagram and Terms	5
2.1	Block Diagram	5
2.2	Terms	5
3	Pin Configuration	6
3.1	Pin Assignment BTS5016SDA	6
3.2	Pin Definitions and Functions	6
4	General Product Characteristics	7
4.1	Absolute Maximum Ratings	7
4.2	Thermal Resistance	8
5	Power Stages	9
5.1	Input Circuit	9
5.2	Output On-State Resistance	10
5.3	Output Inductive Clamp	11
5.3.1	Maximum Load Inductance	11
5.4	Electrical Characteristics	13
6	Protection Functions	15
6.1	Overload Protection	15
6.2	Short circuit impedance	16
6.3	Reverse Polarity Protection - Reversave™	17
6.4	Overvoltage Protection	18
6.5	Loss of Ground Protection	18
6.6	Loss of Vbb Protection	18
6.7	Electrical Characteristics	19
7	Diagnosis	21
7.1	Electrical Characteristics	23
8	Package Outlines	24
9	Revision History	25

**Smart High-Side Power Switch
PROFET™
One Channel**

BTS5016SDA



1 Overview

Features

- Part of scalable product family
- Load current sense
- Reversave™
- Very low standby current
- Current controlled input pin
- Improved electromagnetic compatibility (EMC)
- Fast demagnetization of inductive loads
- Stable behavior at under-voltage
- Green Product (RoHS compliant)
- AEC Qualified



PG-TO252-5-11

Operating voltage	$V_{bb(on)}$	5.5 .. 20 V
Minimum overvoltage protection	$V_{ON(CL)}$	39 V
Maximum on-state resistance at $T_j = 150\text{ °C}$	$R_{DS(ON)}$	32 mΩ
Nominal load current	$I_{L(nom)}$	5.5 A
Minimum current limitation	$I_{L4(SC)}$	45 A
Maximum stand-by current for whole device with load at $T_j = 25\text{ °C}$	$I_{bb(OFF)}$	6 μA

The BTS5016SDA is a one channel high-side power switch in PG-TO252-5-11 package providing embedded protective functions.

The power transistor is built by a N-channel vertical power MOSFET with charge pump. The design is based on Smart SIPMOS chip on chip technology.

The BTS5016SDA has a current controlled input and offers a diagnostic feedback with load current sense and a defined fault signal in case of overload operation, overtemperature shutdown and/or short circuit shutdown.

Type	Package	Marking
BTS5016SDA	PG-TO252-5-11	5016SDA

Protective Functions

- Reversave™, channel switches on in case of reverse polarity
- Reverse battery protection without external components
- Short circuit protection with latch
- Overload protection
- Multi-step current limitation
- Thermal shutdown with restart
- Overvoltage protection (including load dump)
- Loss of ground protection
- Loss of V_{bb} protection (with external diode for charged inductive loads)
- Electrostatic discharge protection (ESD)

Diagnostic Functions

- Proportional load current sense (with defined fault signal in case of overload operation, overtemperature shutdown and/or short circuit shutdown)
- Open load detection in ON-state by load current sense

Applications

- μ C compatible high-side power switch with diagnostic feedback for 12 V grounded loads
- All types of resistive, inductive and capacitive loads
- Most suitable for loads with high inrush currents, so as lamps
- Replaces electromechanical relays, fuses and discrete circuits

2 Block Diagram and Terms

2.1 Block Diagram

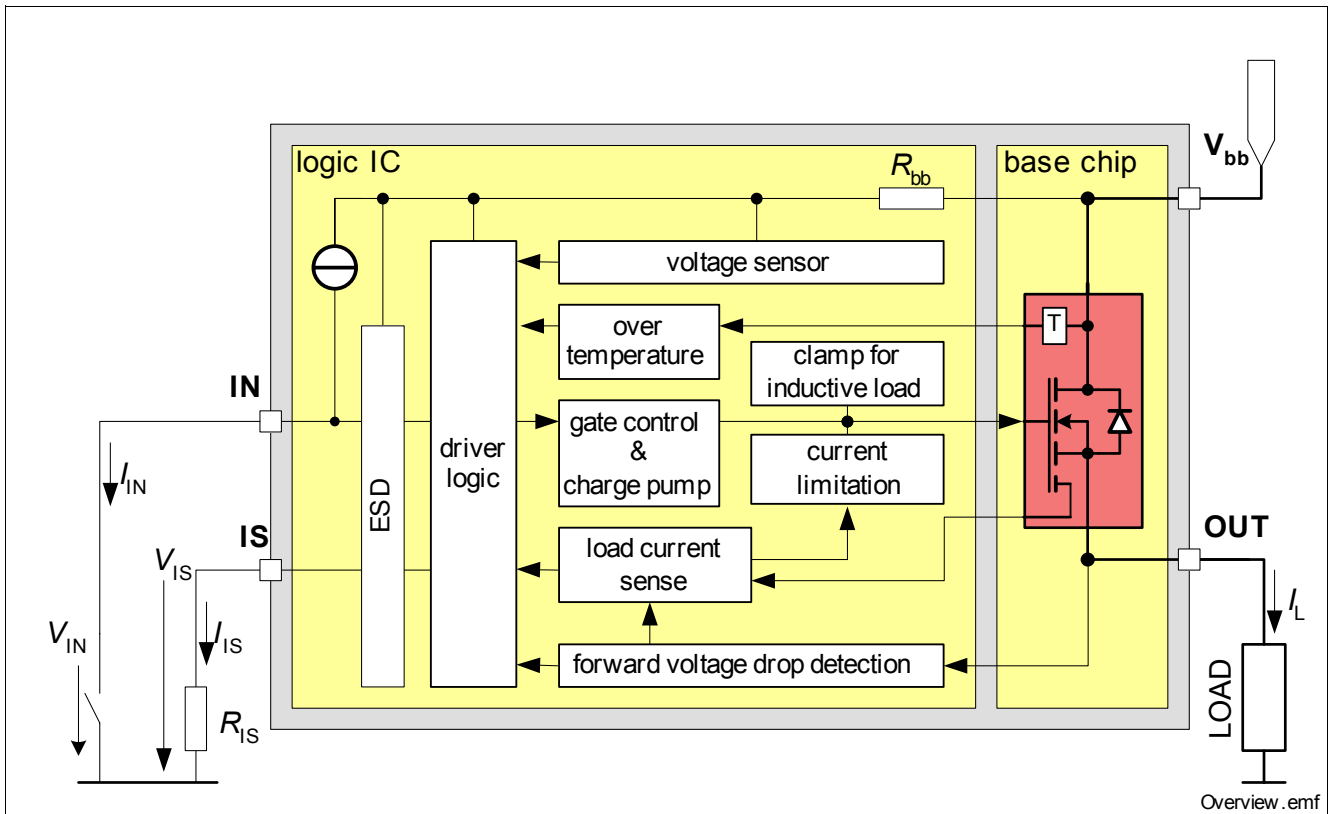

Figure 1 Block Diagram

2.2 Terms

Following figure shows all terms used in this data sheet.

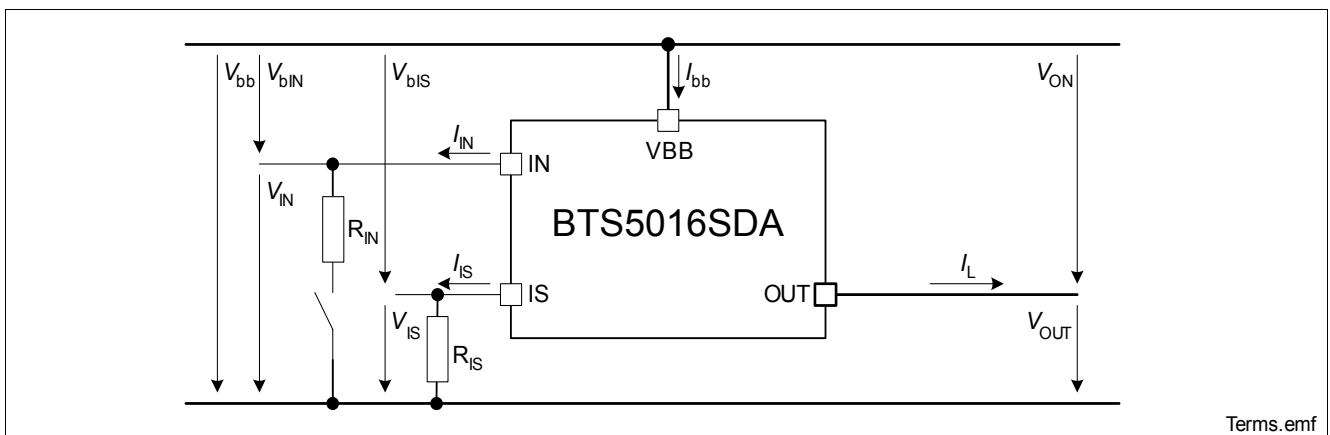
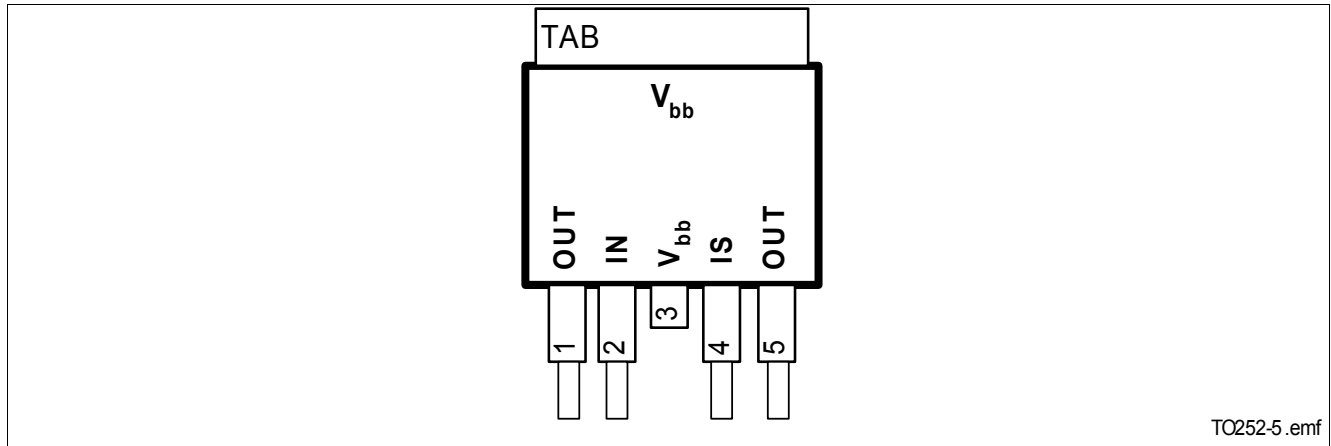

Figure 2 Terms

3 Pin Configuration

3.1 Pin Assignment BTS5016SDA



TO252-5.emf

Figure 3 Pin Configuration

3.2 Pin Definitions and Functions

Pin	Symbol	Function
1	OUT	Output; output to the load; pin 1 and 5 must be externally shorted. ¹⁾
2	IN	Input; activates the power switch if shorted to ground.
3	V_{bb}	Supply Voltage; positive power supply voltage; tab and pin 3 are internally shorted.
4	IS	Sense Output; Diagnostic feedback; provides at normal operation a sense current proportional to the load current; in case of overload, overtemperature and/or short circuit a defined current is provided (see Table 1 "Truth Table" on Page 21).
5	OUT	Output; output to the load; pin 1 and 5 must be externally shorted. ¹⁾
TAB	V_{bb}	Supply Voltage; positive power supply voltage; tab and pin 3 are internally shorted.

1) Not shorting all outputs will considerably increase the on-state resistance, reduce the peak current capability, the clamping capability and decrease the current sense accuracy.

4 General Product Characteristics

4.1 Absolute Maximum Ratings

Absolute Maximum Ratings ¹⁾

$T_j = 25\text{ °C}$ (unless otherwise specified)

Pos.	Parameter	Symbol	Limit Values		Unit	Conditions
			Min.	Max.		

Supply Voltages

4.1.1	Supply voltage	V_{bb}	-16	38	V	–
4.1.2	Supply voltage for short circuit protection (single pulse) ²⁾	$V_{bb(SC)}$	0	20	V	–
4.1.3	Supply Voltage for Load Dump protection ³⁾	$V_{bb(LD)}$	–	45	V	$R_I = 2\ \Omega$, $R_L = 1.5\ \Omega$,

Logic Pins

4.1.4	Voltage at input pin	V_{bIN}	-16	63	V	–
4.1.5	Current through input pin	I_{IN}	-140	15	mA	–
4.1.6	Voltage at current sense pin	V_{bIS}	-16	63	V	–
4.1.7	Current through sense pin	I_{IS}	-140	15	mA	–
4.1.8	Input voltage slew rate ⁴⁾	dV_{bIN}/dt	-20	20	V/ μ s	–

Power Stages

4.1.9	Load current ⁵⁾	I_L	-	$I_{L(SC)}$	A	–
4.1.10	Maximum energy dissipation per channel (single pulse)	E_{AS}	-	0.12	J	$V_{bb} = 12\text{ V}$, $I_{L(0)} = 20\text{ A}$, $T_{j(0)} = 150\text{ °C}$

Temperatures

4.1.11	Junction temperature	T_j	-40	150	°C	–
4.1.12	Storage temperature	T_{stg}	-55	150	°C	–

ESD Susceptibility

4.1.13	ESD susceptibility HBM Pin 2 (IN) Pin 4 (IS) Pin1/5 (OUT)	V_{ESD}	-2 -2 -4	2 2 4	kV	according to EIA/JESD 22-A 114B
--------	--	-----------	----------------	-------------	----	---------------------------------------

- 1) Not subject to production test, specified by design.
- 2) Short circuit is defined as a combination of remaining resistances and inductances. See [Figure 13](#).
- 3) Load Dump is specified in ISO 7637, R_I is the internal resistance of the Load Dump pulse generator.
- 4) Slew rate limitation can be achieved by means of using a series resistor for the small signal driver or in series in the input path. A series resistor R_{IN} in the input path is also required for reverse operation at $V_{bb} \leq -16\text{V}$. See also [Figure 14](#).
- 5) Current limitation is a protection feature. Operation in current limitation is considered as “outside” normal operating range. Protection features are not designed for continuous repetitive operation.

Note: Stresses above the ones listed here may cause permanent damage to the device. Exposure to absolute maximum rating conditions for extended periods may affect device reliability.

Note: Integrated protection functions are designed to prevent IC destruction under fault conditions described in the data sheet. Fault conditions are considered as “outside” normal operating range. Protection functions are not designed for continuous repetitive operation.

4.2 Thermal Resistance

Pos.	Parameter	Symbol	Limit Values			Unit	Conditions
			Min.	Typ.	Max.		
4.2.1	Junction to Case ¹⁾	R_{thjc}	–	–	1.3	K/W	–
4.2.2	Junction to Ambient ¹⁾ free air	R_{thja}	–	80	–	K/W	–
	device on PCB ²⁾		–	45	–		
	device on PCB ³⁾		–	22	–		

- 1) Not subject to production test, specified by design.
- 2) Device mounted on PCB (50 mm x 50 mm x 1.5mm epoxy, FR4) with 6 cm² copper heatsinking area (one layer, 70 μm thick) for V_{bb} connection. PCB is vertical without blown air.
- 3) Specified R_{thJA} value is according to Jedec JESD51-2,-5,-7 at natural convection on FR4 2s2p board; The Product (Chip+Package) was simulated on a 76.2 x 114.3 x 1.5 mm board with 2 inner copper layers (2 x 70μm Cu, 2 x 35μm Cu). Where applicable a thermal via array under the exposed pad contacted the first inner copper layer.

5 Power Stages

The power stage is built by a N-channel vertical power MOSFET (DMOS) with charge pump.

5.1 Input Circuit

Figure 4 shows the input circuit of the BTS5016SDA. The current source to V_{bb} ensures that the device switches off in case of open input pin. The zener diode protects the input circuit against ESD pulses.

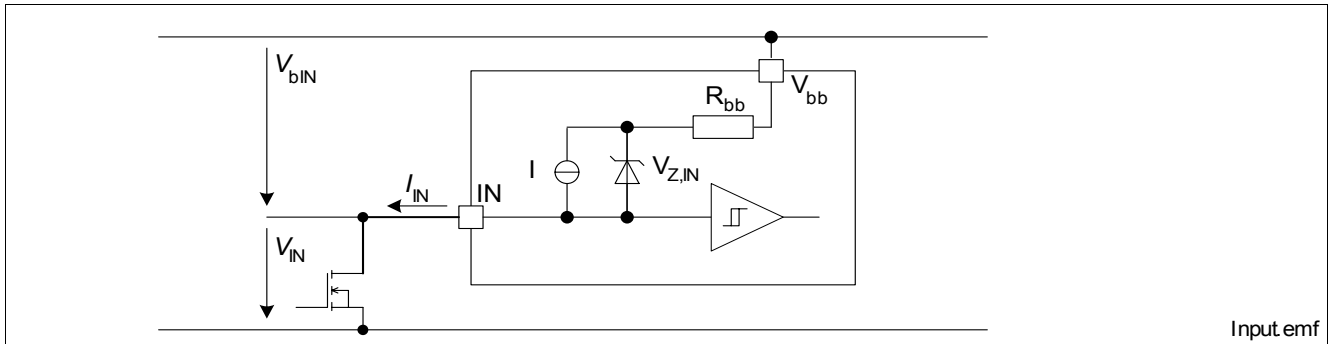

Figure 4 Input Circuit

A high signal at the required external small signal transistor pulls the input pin to ground. A logic supply current I_{IN} is flowing and the power DMOS switches on with a dedicated slope, which is optimized in terms of EMC emission.

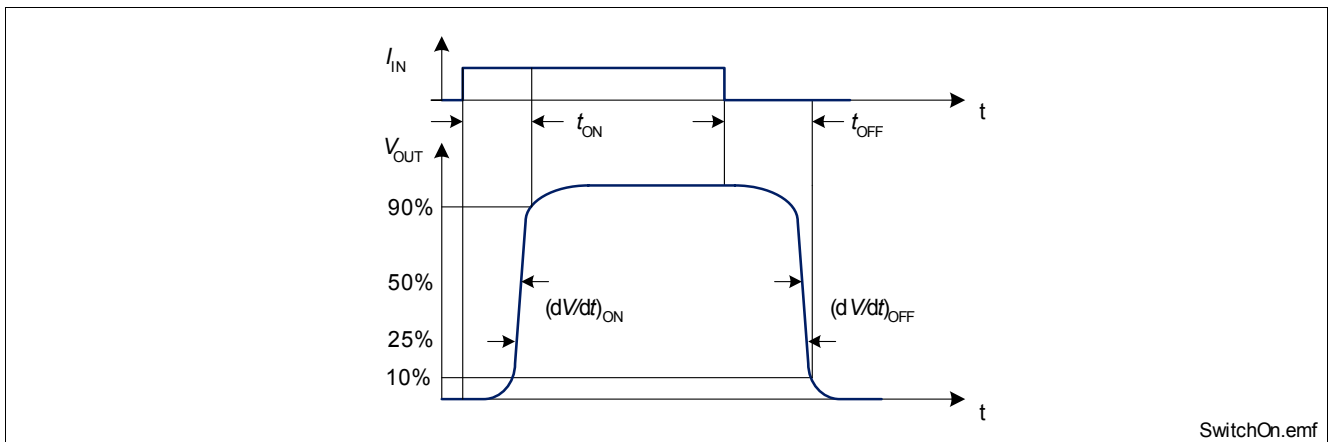

Figure 5 Switching a Load (resistive)

5.2 Output On-State Resistance

The on-state resistance $R_{DS(ON)}$ depends on the supply voltage as well as the junction temperature T_j . **Figure 6** shows these dependencies for the typical on-state resistance. The voltage drop in reverse polarity mode is described in **Section 6.3**.

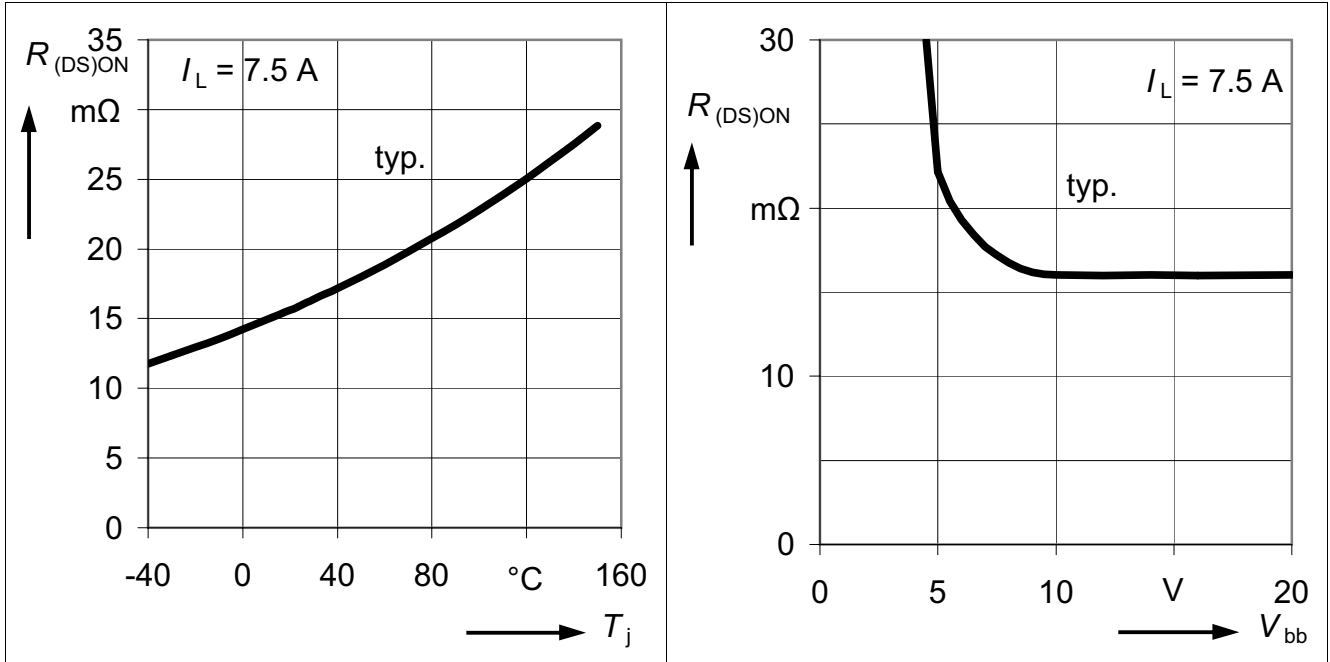

Figure 6 Typical On-State Resistance

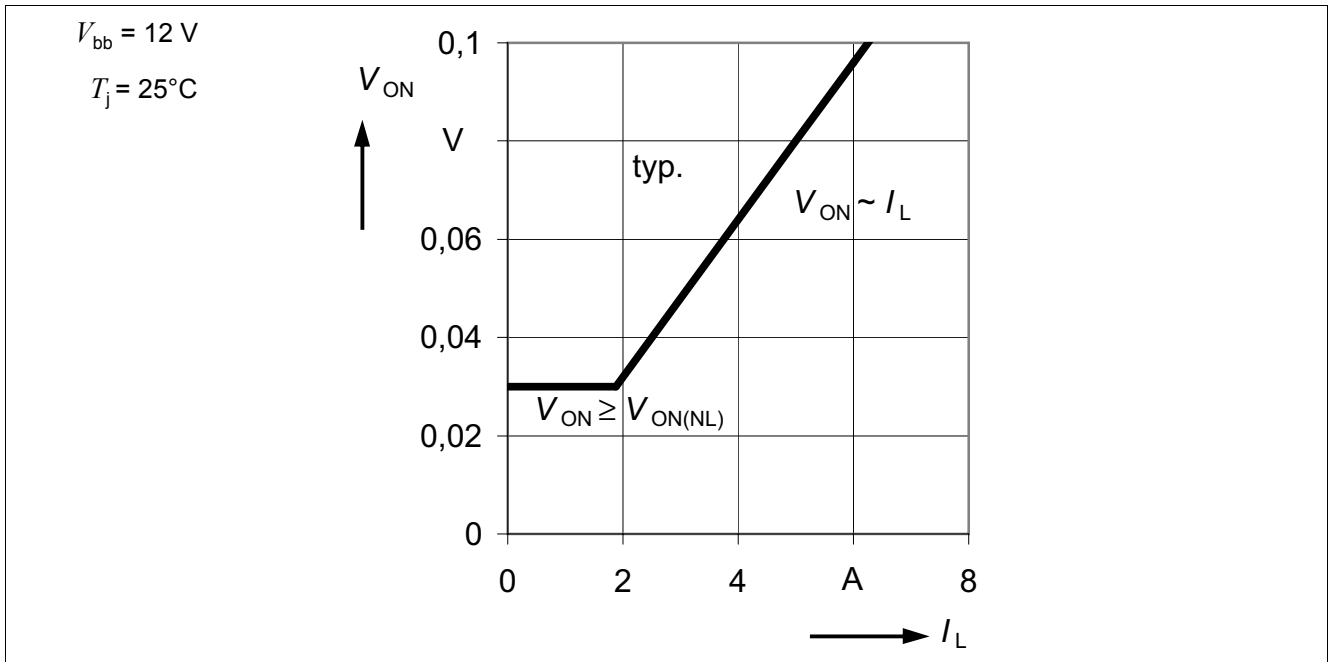

Figure 7 Typical Output Voltage Drop Limitation

5.3 Output Inductive Clamp

When switching off inductive loads, the output voltage V_{OUT} drops below ground potential due to the involved inductance ($-di_L/dt = -v_L/L$; $-V_{OUT} \cong -V_L$).

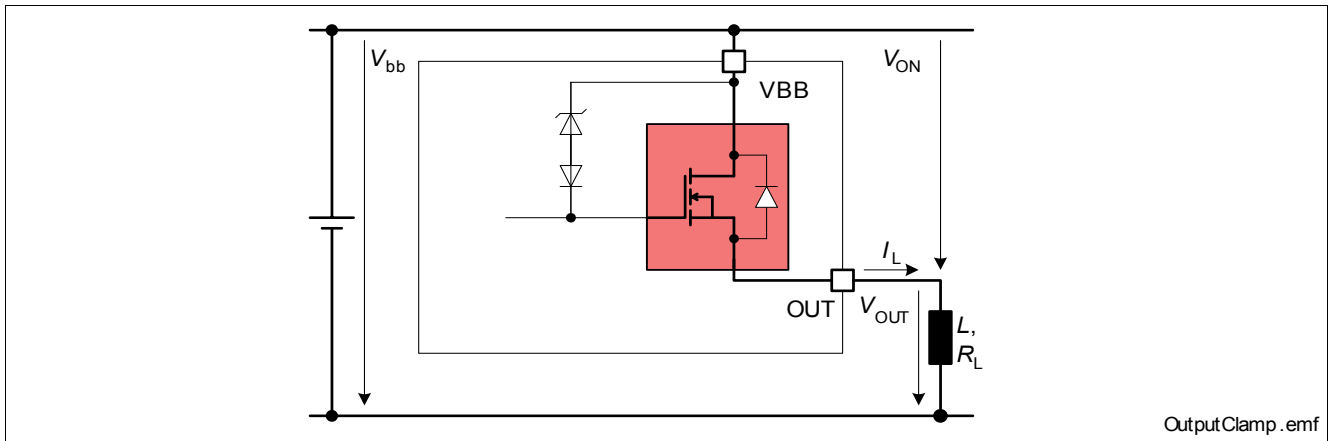

Figure 8 Output Clamp

To prevent destruction of the device, there is a voltage clamp mechanism implemented that keeps the voltage drop across the device at a certain level ($V_{ON(CL)}$). See Figure 8 and Figure 9 for details. The maximum allowed load inductance is limited.

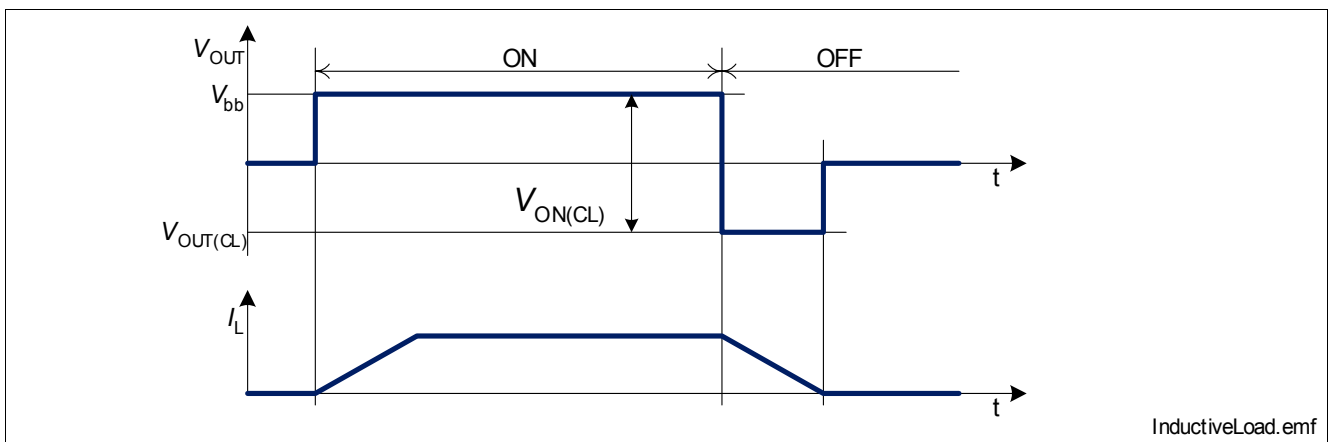

Figure 9 Switching an Inductance

5.3.1 Maximum Load Inductance

While de-energizing inductive loads, energy has to be dissipated in the BTS5016SDA. This energy can be calculated via the following equation:

$$E = V_{ON(CL)} \cdot \left[\frac{V_{bb} - |V_{ON(CL)}|}{R_L} \cdot \ln \left(1 + \frac{R_L \cdot I_L}{|V_{ON(CL)}| - V_{bb}} \right) + I_L \right] \cdot \frac{L}{R_L}$$

In the event of de-energizing very low ohmic inductances ($R_L \approx 0$) the following, simplified equation can be used:

$$E = \frac{1}{2} L I_L^2 \cdot \frac{|V_{ON(CL)}|}{|V_{ON(CL)}| - V_{bb}}$$

The energy, which is converted into heat, is limited by the thermal design of the component. For given starting currents the maximum allowed inductance is therefore limited. See [Figure 10](#) for the maximum allowed inductance at $V_{bb}=12V$.

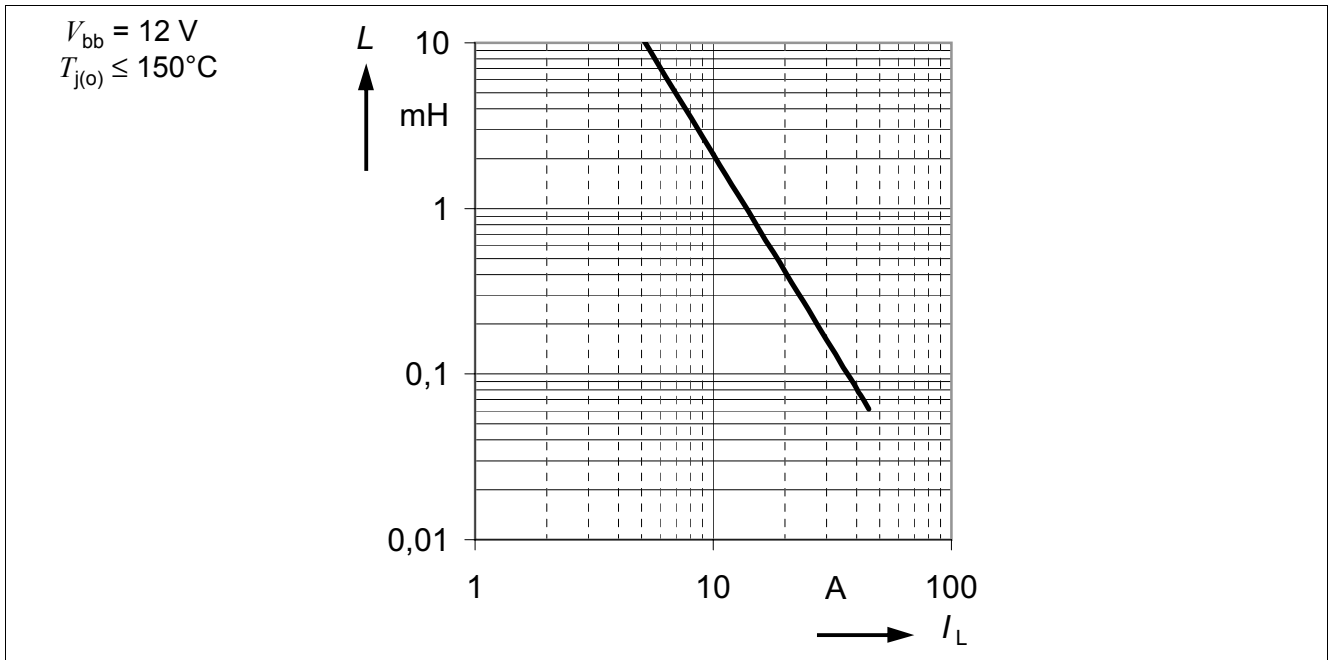

Figure 10 Maximum load inductance for single pulse, $T_{j(0)} \leq 150^\circ\text{C}$.

5.4 Electrical Characteristics

$V_{bb} = 12\text{ V}$, $T_j = -40 \dots 150\text{ °C}$ (unless otherwise specified) Typical values are given at $V_{bb} = 12\text{ V}$, $T_j = 25\text{ °C}$

Pos.	Parameter	Symbol	Limit Values			Unit	Conditions
			Min.	Typ.	Max.		

General

5.4.1	Operating voltage ¹⁾	$V_{bb(\text{on})}$	5.5	-	20	V	$V_{\text{IN}} = 0\text{ V}$
5.4.2	Undervoltage shutdown ²⁾	$V_{\text{bIN}(\text{u})}$	-	2.5	3.5	V	$T_j = 25\text{ °C}$
5.4.3	Undervoltage restart of charge pump	$V_{\text{bb}(\text{ucp})}$	-	4	5.5	V	-
5.4.4	Operating current	I_{IN}	-	1.4	2.2	mA	-
5.4.5	Stand-by current $T_j = -40\text{ °C}$, $T_j = 25\text{ °C}$ $T_j = 150\text{ °C}$	$I_{\text{bb}(\text{OFF})}$	- - -	3 9	6 16	μA	$I_{\text{IN}} = 0\text{ A}$

Input characteristics

5.4.6	Input current for turn-on	$I_{\text{IN}(\text{on})}$	-	1.4	2.2	mA	$V_{\text{bIN}} \geq V_{\text{bb}(\text{ucp})} - V_{\text{IN}}$
5.4.7	Input current for turn-off	$I_{\text{IN}(\text{off})}$	-	-	30	μA	-

Output characteristics

5.4.8	On-state resistance $T_j = 25\text{ °C}$ $T_j = 150\text{ °C}$ $V_{\text{bb}} = 5.5\text{ V}$, $T_j = 25\text{ °C}$ $V_{\text{bb}} = 5.5\text{ V}$, $T_j = 150\text{ °C}$	$R_{\text{DS}(\text{ON})}$	- - - -	16 28 21 37	- 32 - 42	m Ω	$V_{\text{IN}} = 0\text{ V}$, $I_{\text{L}} = 7.5\text{ A}$, (Tab to pin 1 and 5)
5.4.9	Output voltage drop limitation at small load currents	$V_{\text{ON}(\text{NL})}$	-	30	65	mV	-
5.4.10	Nominal load current (Tab to pin 1 & 5) ^{3) 4)}	$I_{\text{L}(\text{nom})}$	5.5	6.5	-	A	$T_{\text{a}} = 85\text{ °C}$, $V_{\text{ON}} \leq 0.5\text{ V}$, $T_j \leq 150\text{ °C}$
5.4.11	Output clamp	$V_{\text{ON}(\text{CL})}$	39	42	-	V	$I_{\text{L}} = 40\text{ mA}$, $T_j = 25\text{ °C}$
5.4.12	Inverse current output voltage drop ^{2) 5)} (Tab to pin 1 and 5) $T_j = 25\text{ °C}$ $T_j = 150\text{ °C}$	$-V_{\text{ON}(\text{inv})}$	- -	800 600	- -	mV	$I_{\text{L}} = -7.5\text{ A}$, $R_{\text{IS}} = 1\text{ k}\Omega$

Timings

5.4.13	Turn-on time to 90% V_{OUT}	t_{ON}	-	250	500	μs	$R_{\text{L}} = 2.2\text{ }\Omega$
5.4.14	Turn-off time to 10% V_{OUT}	t_{OFF}	-	250	500	μs	$R_{\text{L}} = 2.2\text{ }\Omega$
5.4.15	Turn-on delay after inverse operation ²⁾	$t_{\text{d}(\text{inv})}$	-	1	-	ms	$V_{\text{bb}} > V_{\text{OUT}}$, $V_{\text{IN}(\text{inv})} =$ $V_{\text{IN}(\text{fwd})} = 0\text{ V}$

$V_{bb} = 12\text{ V}$, $T_j = -40 \dots 150\text{ °C}$ (unless otherwise specified) Typical values are given at $V_{bb} = 12\text{ V}$, $T_j = 25\text{ °C}$

Pos.	Parameter	Symbol	Limit Values			Unit	Conditions
			Min.	Typ.	Max.		
5.4.16	Slew rate On 25% to 50% V_{OUT}	$(dV/dt)_{ON}$	-	0.3	0.6	V/ μ s	$R_L = 2.2\ \Omega$,
5.4.17	Slew rate Off 50% to 25% V_{OUT}	$-(dV/dt)_{OFF}$	-	0.3	0.6	V/ μ s	$R_L = 2.2\ \Omega$,

- 1) Please mind the limitations of the embedded protection functions. See [Chapter 4.1](#) and [Chapter 6](#) for details.
- 2) Not subject to production test, specified by design
- 3) Device mounted on PCB (50 mm x 50 mm x 1.5mm epoxy, FR4) with 6 cm² copper heatsinking area (one layer, 70 μ m thick) for V_{bb} connection. PCB is vertical without blown air.
- 4) Not subject to production test, parameters are calculated from $R_{DS(ON)}$ and R_{th}
- 5) During inverse operation ($I_L < 0\text{ A}$, $V_{bIN} > 0\text{ V}$), a current through the intrinsic body diode causing a voltage drop of $V_{ON(inv)}$ results in a delayed switch on with a time delay $t_{d(inv)}$ after the transition from inverse to forward operation. A sense current $I_{IS(fault)}$ can be provided by the pin IS until standard forward operation is reached.

*Note: Characteristics show the deviation of parameter at the given supply voltage and junction temperature.
Typical values show the typical parameters expected from manufacturing.*

6 Protection Functions

The device provides embedded protective functions. Integrated protection functions are designed to prevent IC destruction under fault conditions described in the data sheet. Fault conditions are considered as “outside” normal operating range. Protection functions are neither designed for continuous nor repetitive operation.

6.1 Overload Protection

The load current I_L is limited by the device itself in case of overload or short circuit to ground. There are multiple steps of current limitation $I_{L(SC)}$ which are selected automatically depending on the voltage drop V_{ON} across the power DMOS. Please note that the voltage at the OUT pin is $V_{bb} - V_{ON}$. **Figure 11** shows the dependency for a typical device.

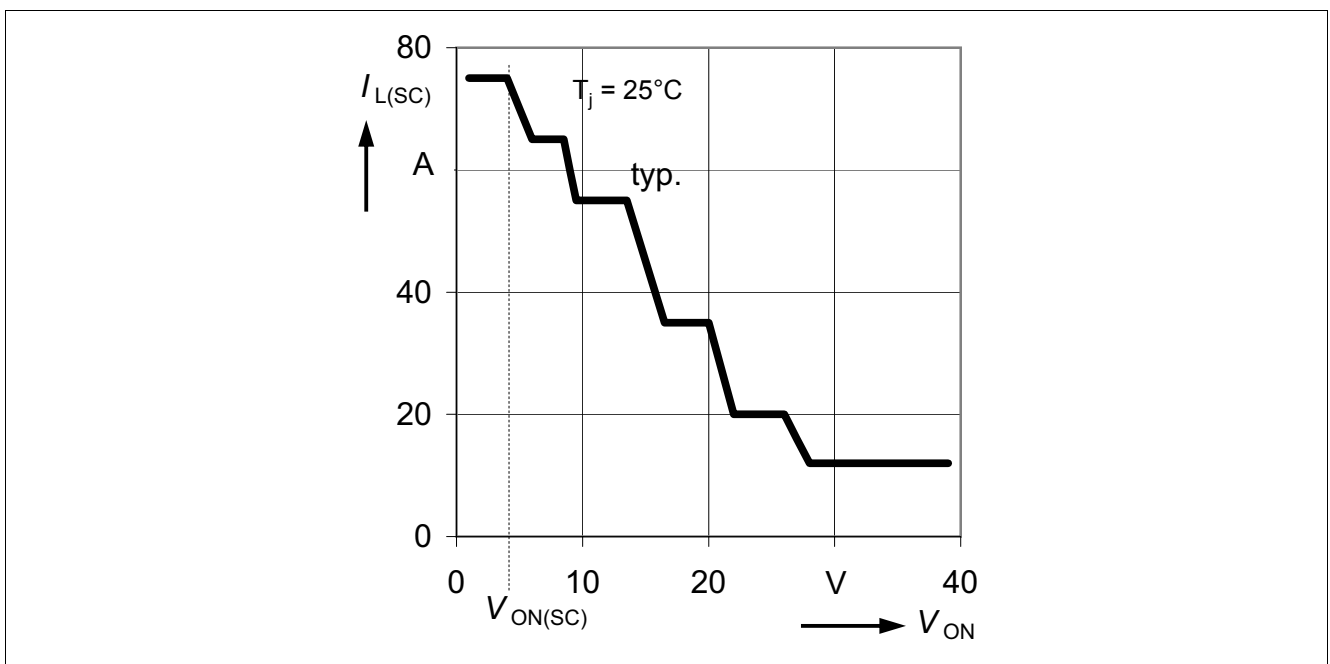

Figure 11 Typical Current Limitation

Depending on the severity of the short condition as well as on the battery voltage the resulting voltage drop across the device varies.

Whenever the resulting voltage drop V_{ON} exceeds the short circuit detection threshold $V_{ON(SC)}$, the device will switch off immediately and latch until being reset via the input. The $V_{ON(SC)}$ detection functionality is activated, when $V_{bIN} > 10V$ typ. and the blanking time $t_{d(SC1)}$ expired after switch on.

In the event that either the short circuit detection via $V_{ON(SC)}$ is not activated or that the on chip temperature sensor senses overtemperature before the blanking time $t_{d(SC1)}$ expired, the device switches off resulting from overtemperature detection. After cooling down with thermal hysteresis, the device switches on again. The device will react as during normal switch on triggered by the input signal. Please refer to **Figure 12** and **Figure 19** for details.

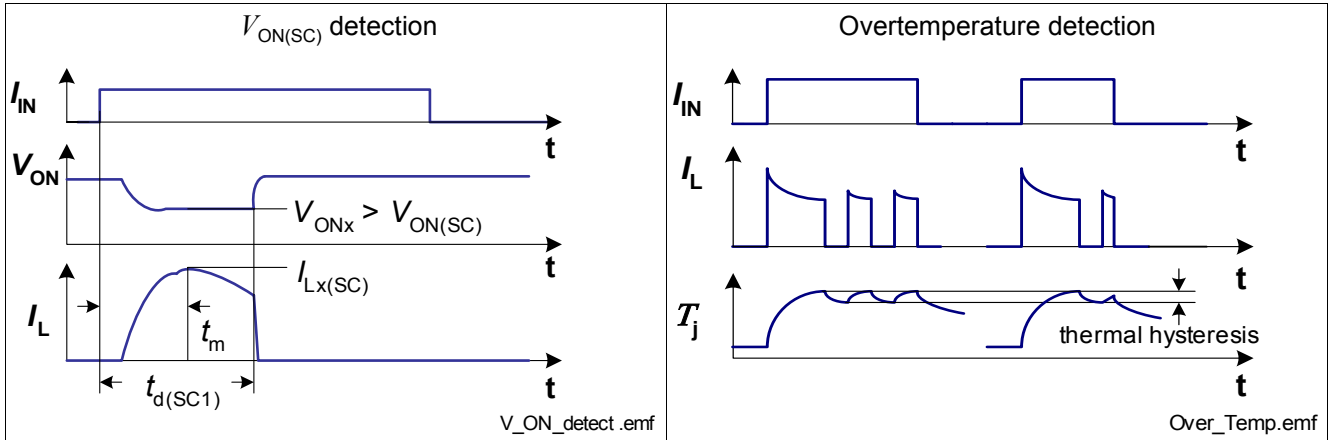

Figure 12 Overload Behavior

6.2 Short circuit impedance

The capability to handle single short circuit events depends on the battery voltage as well as on the primary and secondary short impedance. Figure 13 outlines allowable combinations for a single short circuit event of maximum, secondary inductance for given secondary resistance.

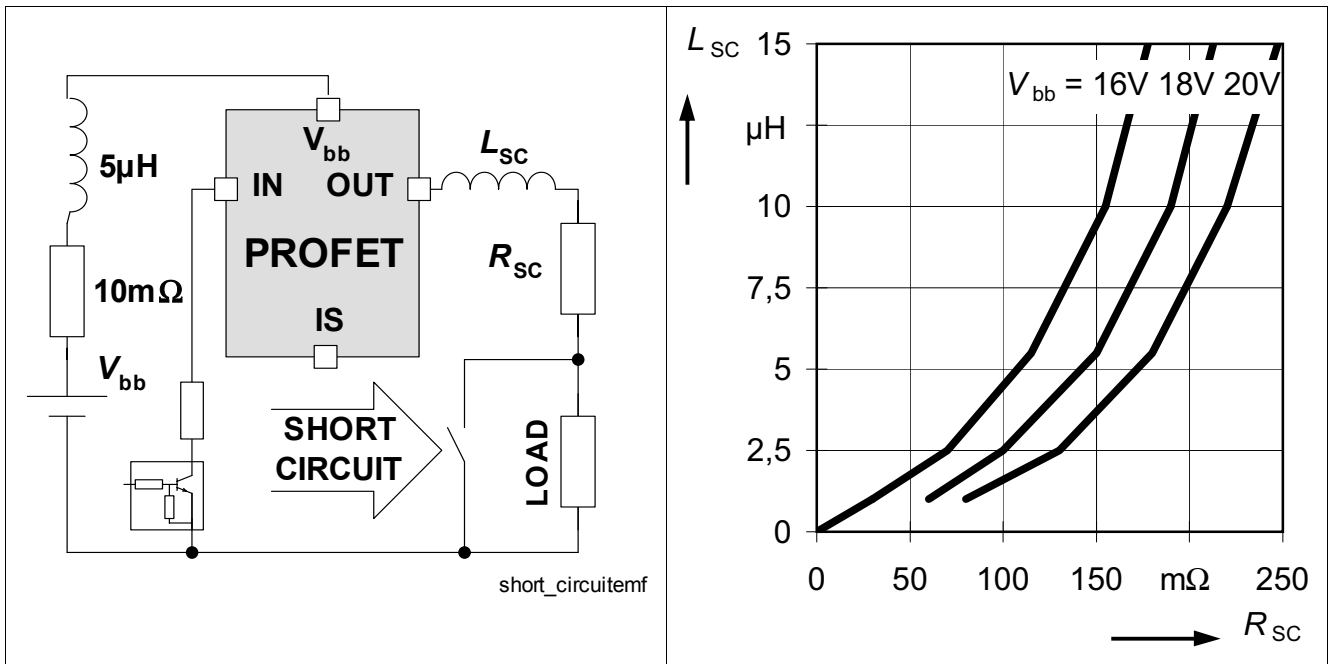

Figure 13 Short circuit

6.3 Reverse Polarity Protection - Reversave™

The device can not block a current flow in reverse polarity condition. In order to minimize power dissipation, the device offers Reversave™ functionality. In reverse polarity condition the channel will be switched on provided a sufficient gate to source voltage is generated $V_{GS} \approx V_{Rbb}$. Please refer to [Figure 14](#) for details.

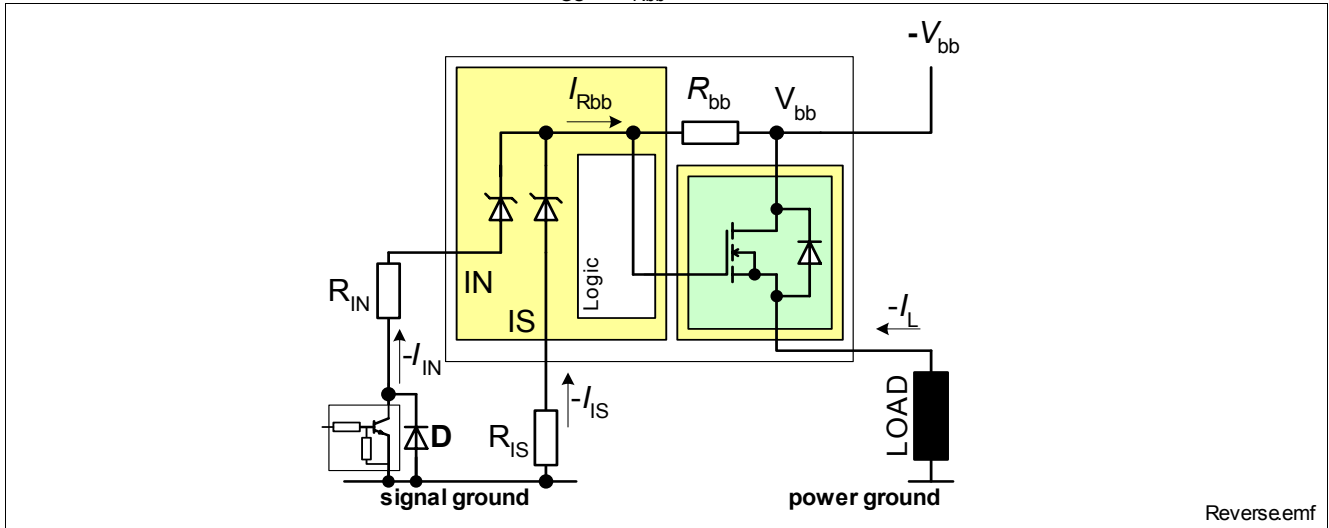

Figure 14 Reverse battery protection

Additional power is dissipated by the integrated R_{bb} resistor. Use following formula for estimation of overall power dissipation $P_{diss(rev)}$ in reverse polarity mode.

$$P_{diss(rev)} \approx R_{ON(rev)} \cdot I_L^2 + R_{bb} \cdot I_{Rbb}^2$$

For reverse battery voltages up to $V_{bb} < 16V$ the pin IN or the pin IS should be low ohmic connected to signal ground. This can be achieved e.g. by using a small signal diode D in parallel to the input switch or by using a small signal MOSFET driver. For reverse battery voltages higher then $V_{bb} = 16V$ an additional resistor R_{IN} is recommended. The overall current through R_{bb} should not be above 80 mA.

$$\frac{1}{R_{IN}} + \frac{1}{R_{IS}} = \frac{0.08A}{|V_{bb}| - 12V}$$

Note: No protection mechanism is active during reverse polarity. The IC logic is not functional.

6.4 Overvoltage Protection

Beside the output clamp for the power stage as described in [Section 5.3](#) there is a clamp mechanism implemented for all logic pins. See [Figure 15](#) for details.

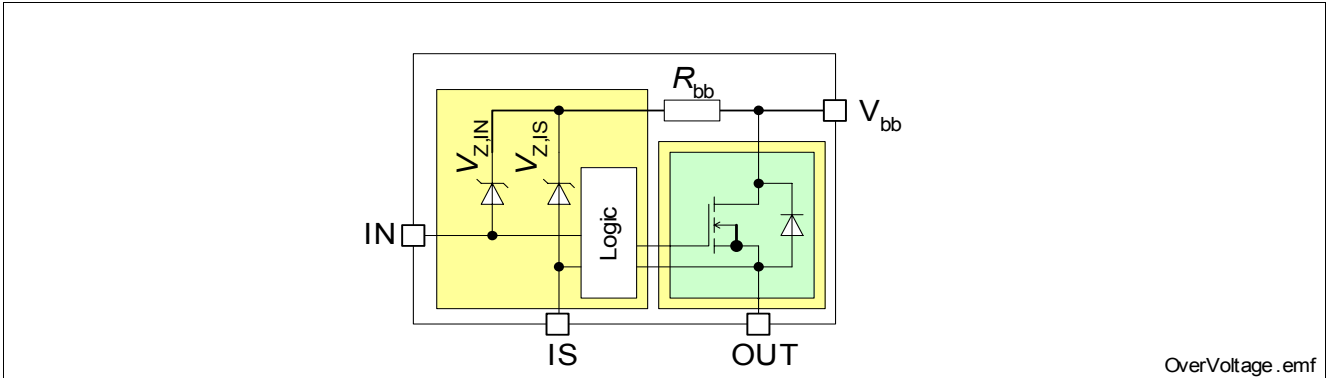

Figure 15 Overvoltage Protection

6.5 Loss of Ground Protection

In case of complete loss of the device ground connections the BTS5016SDA securely changes to or remains in off state.

6.6 Loss of V_{bb} Protection

In case of complete loss of V_{bb} the BTS5016SDA remains in off state.

In case of loss of V_{bb} connection with charged inductive loads a current path with load current capability has to be provided, to demagnetize the charged inductances. It is recommended to use a diode, a Z-diode, or a varistor ($V_{ZL} + V_D < 30\text{ V}$ or $V_{Zb} + V_D < 16\text{ V}$ if $R_{IN} = 0$). For higher clamp voltages currents through IN and IS have to be limited to -120 mA . Please refer to [Figure 16](#) for details.

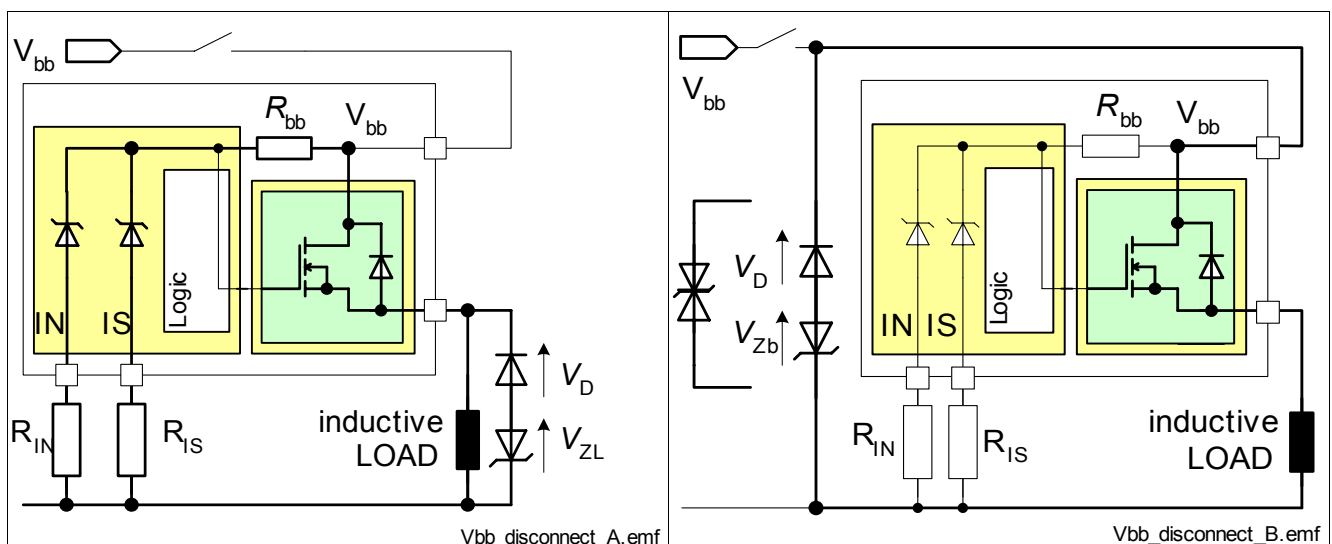

Figure 16 Loss of V_{bb}

6.7 Electrical Characteristics

$V_{bb} = 12\text{ V}$, $T_j = -40 \dots 150\text{ °C}$ (unless otherwise specified) Typical values are given at $V_{bb} = 12\text{ V}$, $T_j = 25\text{ °C}$

Pos.	Parameter	Symbol	Limit Values			Unit	Conditions
			Min.	Typ.	Max.		

Overload Protection

6.7.1	Load current limitation ^{1) 2)} $T_j = -40\text{ °C}$ $T_j = +25\text{ °C}$ $T_j = +150\text{ °C}$	$I_{L4(SC)}$	- - 45	80 75 60	110 - -	A	$V_{ON} = 4\text{ V}$, (Tab to pin 1 and 5)
6.7.2	Load current limitation ^{1) 2)} $T_j = -40\text{ °C}$ $T_j = +25\text{ °C}$ $T_j = +150\text{ °C}$	$I_{L6(SC)}$	- - 32	75 65 55	100 - -	A	$V_{ON} = 6\text{ V}$, (Tab to pin 1 and 5)
6.7.3	Load current limitation ²⁾ $T_j = -40\text{ °C}$ $T_j = +25\text{ °C}$ $T_j = +150\text{ °C}$	$I_{L12(SC)}$	- - 26	65 55 45	90 - -	A	$V_{ON} = 12\text{ V}$, $t_m = 170\text{ }\mu\text{s}$, (Tab to pin 1 and 5)
6.7.4	Load current limitation ^{1) 2)} $T_j = -40\text{ °C}$ $T_j = +25\text{ °C}$ $T_j = +150\text{ °C}$	$I_{L18(SC)}$	- - 18	40 35 30	55 - -	A	$V_{ON} = 18\text{ V}$, (Tab to pin 1 and 5)
6.7.5	Load current limitation ^{1) 2)} $T_j = -40\text{ °C}$ $T_j = +25\text{ °C}$ $T_j = +150\text{ °C}$	$I_{L24(SC)}$	- - 10	20 20 15	35 - -	A	$V_{ON} = 24\text{ V}$, (Tab to pin 1 and 5)
6.7.6	Load current limitation ^{1) 2)} $T_j = -40\text{ °C}$ $T_j = +25\text{ °C}$ $T_j = +150\text{ °C}$	$I_{L30(SC)}$	- - -	12 12 12	- - -	A	$V_{ON} = 30\text{ V}$, (Tab to pin 1 and 5)
6.7.7	Short circuit shutdown detection voltage ¹⁾	$V_{ON(SC)}$	2.5	3.5	4.5	V	$V_{BIN} > 10\text{ V typ.}$, $T_j = 25\text{ °C}$
6.7.8	Short circuit shutdown delay after input current pos. slope ³⁾	$t_{d(SC1)}$	200	650	1200	μs	$V_{ON} > V_{ON(SC)}$
6.7.9	Thermal shut down temperature	$T_{j(SC)}$	150	165 ¹⁾	-	$^{\circ}\text{C}$	-
6.7.10	Thermal hysteresis ¹⁾	ΔT_j	-	10	-	K	-

Reverse Polarity

6.7.11	On-State resistance in case of reverse polarity $V_{bb} = -8\text{ V}$, $T_j = 25\text{ °C}$ ¹⁾ $V_{bb} = -8\text{ V}$, $T_j = 150\text{ °C}$ ¹⁾ $V_{bb} = -12\text{ V}$, $T_j = 25\text{ °C}$ $V_{bb} = -12\text{ V}$, $T_j = 150\text{ °C}$	$R_{ON(rev)}$	- - - -	19 32 18 31	- 44 - 40	m Ω	$V_{IN} = 0\text{ V}$, $I_L = -7.5\text{ A}$, $R_{IS} = 1\text{ k}\Omega$, (pin 1 and 5 to TAB)
6.7.12	Integrated resistor in V_{bb} line	R_{bb}	-	100	150	Ω	$T_j = 25\text{ °C}$

Protection Functions

$V_{bb} = 12\text{ V}$, $T_j = -40 \dots 150\text{ °C}$ (unless otherwise specified) Typical values are given at $V_{bb} = 12\text{ V}$, $T_j = 25\text{ °C}$

Pos.	Parameter	Symbol	Limit Values			Unit	Conditions
			Min.	Typ.	Max.		
Overvoltage							
6.7.13	Overvoltage protection	V_Z				V	$I_{bb} = 15\text{ mA}$
	Input pin	$V_{Z,IN}$	63	-	-	V	
	Sense pin	$V_{Z,IS}$	63	-	-	V	

- 1) Not subject to production test, specified by design
- 2) Short circuit current limit for max. duration of $t_{d(SC1)}$, prior to shutdown, see also [Figure 12](#).
- 3) min. value valid only if input "off-signal" time exceeds 30 μs

7 Diagnosis

For diagnosis purpose, the BTS5016SDA provides an IntelliSense signal at the pin IS.

The pin IS provides during normal operation a sense current, which is proportional to the load current as long as $V_{bIS} > 5V$. The ratio of the output current is defined as $k_{ILIS} = I_L / I_{IS}$. During switch-on no current is provided, until the forward voltage drops below $V_{ON} < 1V$ typ. The output sense current is limited to $I_{IS(lim)}$.

The pin IS provides in case of any fault conditions a defined fault current $I_{IS(fault)}$ as long as $V_{bIS} > 8V$. Fault conditions are overcurrent ($V_{ON} > 1V$ typ.), current limit or overtemperature switch off.

The pin IS provides no current during open load in ON and de-energisation of inductive loads.

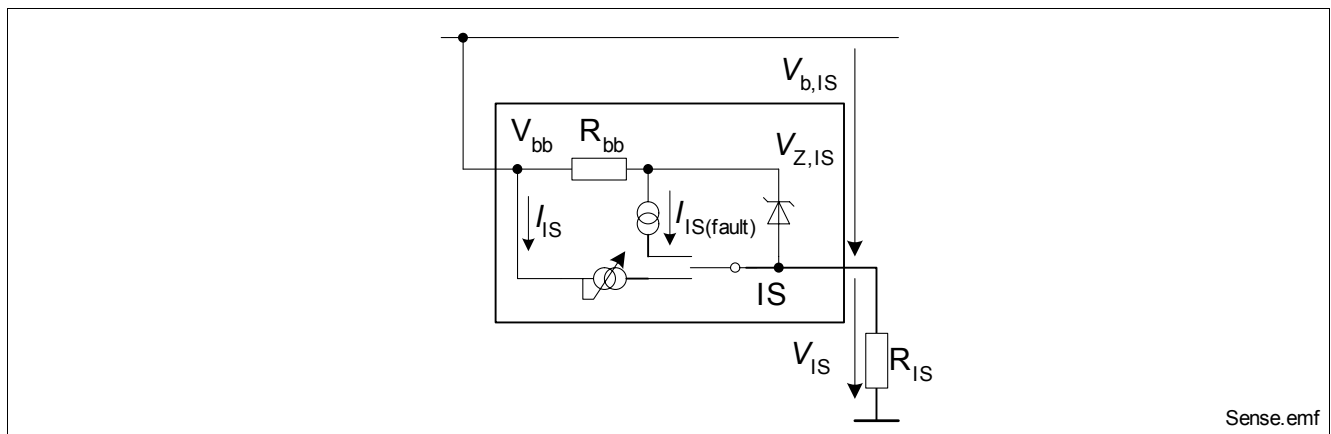

Figure 17 Block Diagram: Diagnosis

Table 1 Truth Table

Parameter	Input Current Level	Output Level	Current Sense I_{IS}
Normal operation	L ¹⁾ H ¹⁾	L H	≈ 0 ($I_{IS(LL)}$) nominal
Overload	L H	L H	≈ 0 ($I_{IS(LL)}$) $I_{IS(fault)}$
Short circuit to GND	L H	L L	≈ 0 ($I_{IS(LL)}$) $I_{IS(fault)}$
Overtemperature	L H	L L	≈ 0 ($I_{IS(LL)}$) $I_{IS(fault)}$
Short circuit to V_{bb}	L H	H H	≈ 0 ($I_{IS(LL)}$) < nominal ²⁾
Open load	L H	Z ¹⁾ H	≈ 0 ($I_{IS(LL)}$) ≈ 0 ($I_{IS(LH)}$)

1) H = "High" Level, L = "Low" Level, Z = high impedance, potential depends on external circuit

2) Low ohmic short to V_{bb} may reduce the output current I_L and therefore also the sense current I_{IS} .

The accuracy of the provided current sense ratio ($k_{ILIS} = I_L / I_{IS}$) depends on the load current. Please refer to [Figure 18](#) for details. A typical resistor R_{IS} of 1 k Ω is recommended.

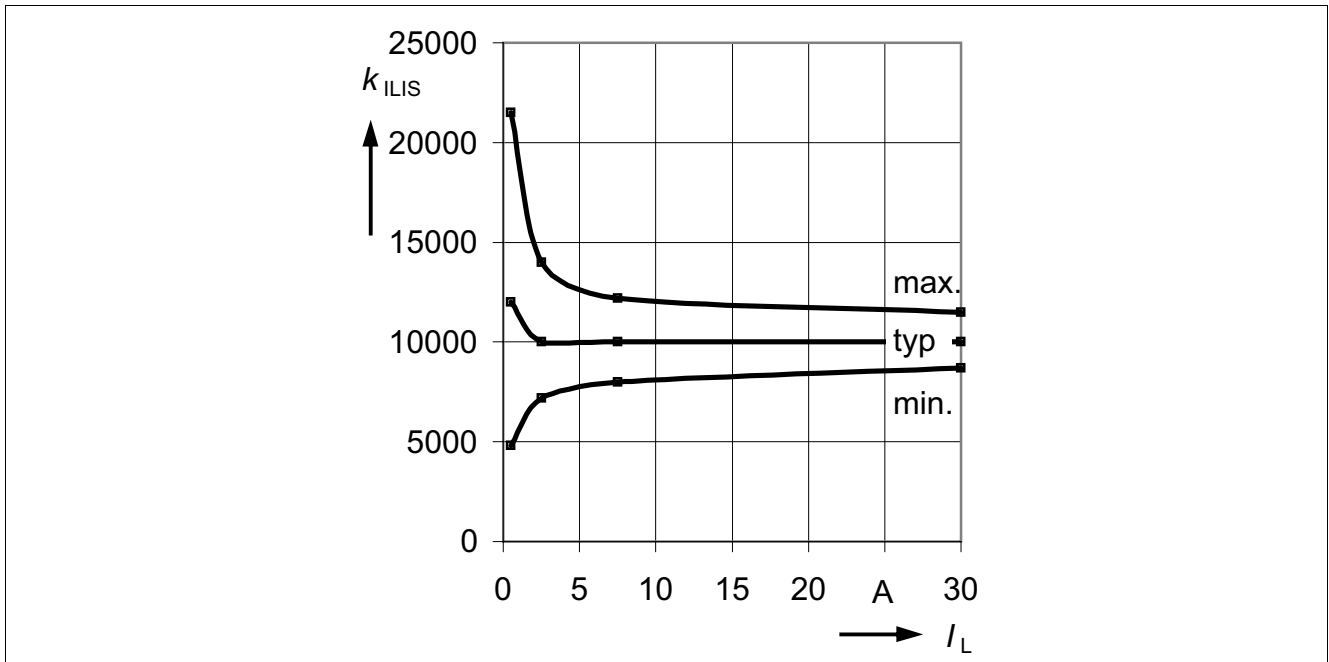

Figure 18 Current sense ratio k_{ILIS} ¹⁾

Details about timings between the diagnosis signal I_{IS} , the forward voltage drop V_{ON} and the load current I_L in ON-state can be found in [Figure 19](#).

Note: During operation at low load current and at activated forward voltage drop limitation the “two level control” of $V_{ON(NL)}$ can cause a sense current ripple synchronous to the “two level control” of $V_{ON(NL)}$. The ripple frequency increases at reduced load currents.

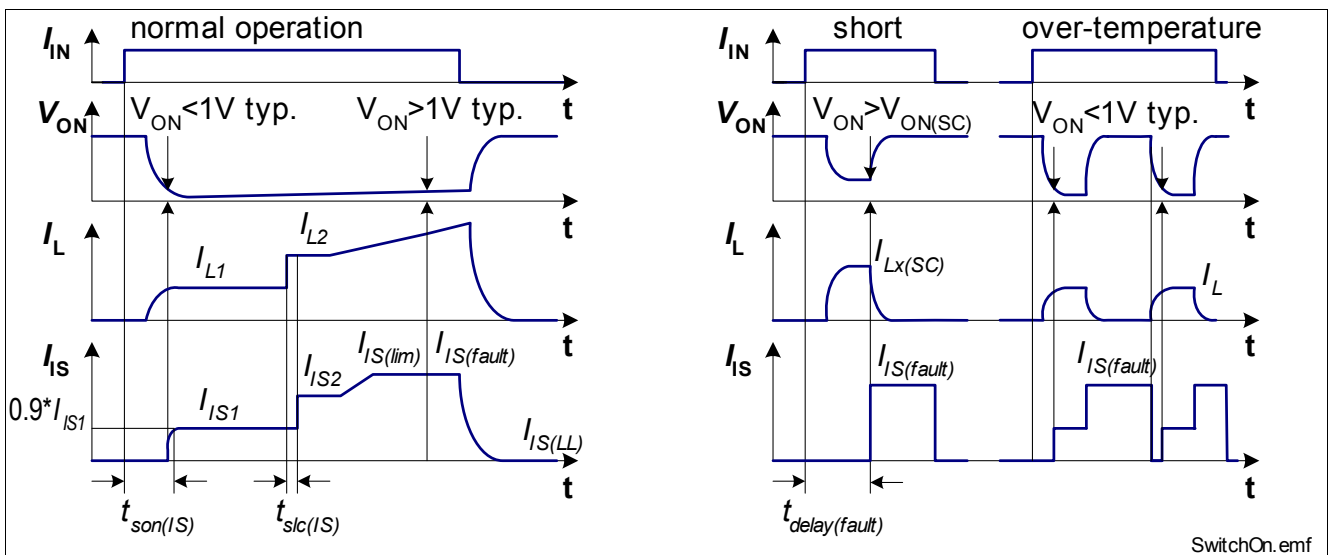

Figure 19 Timing of Diagnosis Signal in ON-state

1) The curves show the behavior based on characterization data. The marked points are specified in this Datasheet in [Section 7.1](#) (Position 7.1.1).

7.1 Electrical Characteristics

$V_{bb} = 12\text{ V}$, $T_j = -40 \dots 150\text{ °C}$ (unless otherwise specified) Typical values are given at $V_{bb} = 12\text{ V}$, $T_j = 25\text{ °C}$

Pos.	Parameter	Symbol	Limit Values			Unit	Conditions
			Min.	Typ.	Max.		
Load Current Sense							
7.1.1	Current sense ratio, static on-condition $I_L = 30\text{ A}$ $I_L = 7.5\text{ A}$ $I_L = 2.5\text{ A}$ $I_L = 0.5\text{ A}$ $I_{IN} = 0$ (e.g. during de energizing of inductive loads) ¹⁾	k_{ILIS}	-	10	-	k	$V_{IN} = 0\text{ V}$, $I_{IS} < I_{IS(lim)}$
			8.7	10	11.5		
			8.0	10	12.2		
			7.2	10	14		
			4.8	12	21.5		
			disabled			-	-
7.1.2	Sense saturation current ¹⁾	$I_{IS(lim)}$	4.0	6	7.5	mA	$V_{ON} < 1\text{ V}$, typ.
7.1.3	Sense current under fault conditions	$I_{IS(fault)}$	4.0	5.2	7.5	mA	$V_{ON} > 1\text{ V}$, typ.
7.1.4	Current sense leakage current	$I_{IS(LL)}$	-	0.1	0.5	μA	$I_{IN} = 0$
7.1.5	Current sense offset current	$I_{IS(LH)}$	-	0.1	1	μA	$V_{IN} = 0$, $I_L \leq 0$
7.1.6	Current sense settling time to 90% $I_{IS_stat.}$ ¹⁾	$t_{son(IS)}$	-	350	700	μs	$I_L = 0 \text{ } \square \text{ } 20\text{ A}$
7.1.7	Current sense settling time to 90% $I_{IS_stat.}$ ¹⁾	$t_{slc(IS)}$	-	50	100	μs	$I_L = 10 \text{ } \square \text{ } 20\text{ A}$
7.1.8	Fault-Sense signal delay after input current positive slope	$t_{delay(fault)}$	200	650	1200	μs	$V_{ON} > 1\text{ V}$, typ.

1) Not subject to production test, specified by design

8 Package Outlines

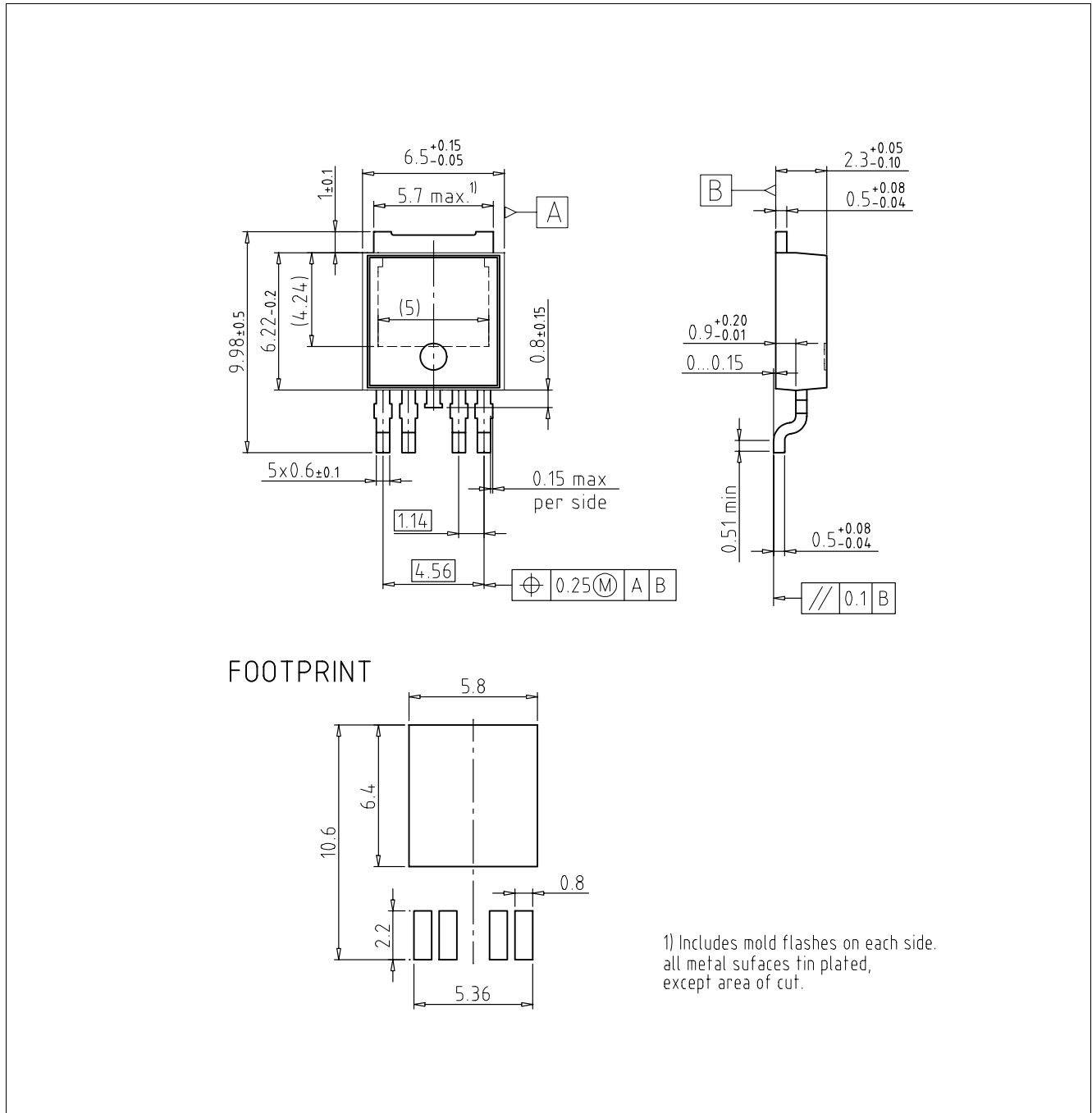

Figure 20 PG-TO252-5-11

Green Product

To meet the world-wide customer requirements for environmentally friendly products and to be compliant with government regulations the device is available as a green product. Green products are RoHS-Compliant (i.e Pb-free finish on leads and suitable for Pb-free soldering according to IPC/JEDEC J-STD-020).

You can find all of our packages, sorts of packing and others in our Infineon Internet Page "Products": <http://www.infineon.com/packages>.

Dimensions in mm

9 Revision History

Version	Date	Changes
Datasheet Rev. 1.1	2008-11-04	Page 13: Parameter IIN(off) updated from maximum 10 μ A to maximum 30 μ A.
Datasheet Rev. 1.0	2008-01-22	Initial version of datasheet

Edition 2008-11-04

**Published by
Infineon Technologies AG
81726 Munich, Germany**

**© 2008 Infineon Technologies AG
All Rights Reserved.**

Legal Disclaimer

The information given in this document shall in no event be regarded as a guarantee of conditions or characteristics. With respect to any examples or hints given herein, any typical values stated herein and/or any information regarding the application of the device, Infineon Technologies hereby disclaims any and all warranties and liabilities of any kind, including without limitation, warranties of non-infringement of intellectual property rights of any third party.

Information

For further information on technology, delivery terms and conditions and prices, please contact the nearest Infineon Technologies Office (www.infineon.com).

Warnings

Due to technical requirements, components may contain dangerous substances. For information on the types in question, please contact the nearest Infineon Technologies Office.

Infineon Technologies components may be used in life-support devices or systems only with the express written approval of Infineon Technologies, if a failure of such components can reasonably be expected to cause the failure of that life-support device or system or to affect the safety or effectiveness of that device or system. Life support devices or systems are intended to be implanted in the human body or to support and/or maintain and sustain and/or protect human life. If they fail, it is reasonable to assume that the health of the user or other persons may be endangered.

www.infineon.com